

OWNERS MANUAL

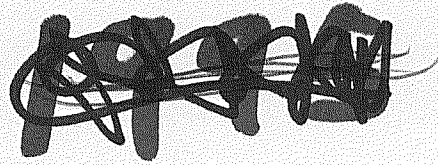

1994

**AIRSTREAM
190
MOTORHOME**

2001

INTRODUCTION

The Owners manual for your new Airstream motorhome is designed to explain the operation, function and care of the many systems that make traveling a joy.

Airstream realizes our customers possess varying degrees of expertise in the area of repairing and maintaining the appliances in their unit. For this reason, the service and trouble-shooting information found in this manual, and your Silver Key Notebook, is directed toward those with average mechanical skills. We also realize you may be more familiar in one area than you are in another. Only you know your capabilities and limitations.

We want you to use this manual, and hope you will find the information contained in it useful; however, should you ever feel you may be "getting in over your head" please see your dealer to have the repairs made.

Appliance manufacturer's information is supplied in a packet included with this manual.

All information, illustrations and specifications contained in the literature is based on the latest product information available at the time of publication approval.

Throughout this manual CAUTION and WARNING notations are used. Failure to observe "caution" can damage equipment. "Warning" notes the possibility of personal injury if not observed.

Note: If and when new materials and production techniques are developed which can improve the quality of its product, or material substitutions are necessary due to availability, Airstream reserves the right to make such changes.

TABLE OF CONTENTS

WARRANTY	1
Explanation of Warranty.....	4
MAINTENANCE SCHEDULE	5
CAMPING	6
Safety	6
Overnight Stop.....	7
Extended Stay	8
EXTERIOR	9
Cleaning.....	9
INTERIOR	10
Drapes, Upholstery, Carpet.....	10
Counter Tops.....	10
Galley Sink	10
Plastic Bathroom Components	11
Sofa Bed.....	11
Table	11
Sliding Windows.....	11
Smoke Detector	12
Fire Extinguisher	13
PLUMBING	14
LP Gas	14
LP Gas Regulator	14
Water System Self Contained	16
Water Pump	16
Water Pump Filter.....	16
Cleaning Fresh Water Tank	17
City Water Hookup.....	17
Winterizing/Storage.....	18
Drain and Waste System.....	19
WATER PUMP	20
TOILET	22
ELECTRICAL	24
Breakers	24
Fuses	24
Lights	25
Roof Vents	25
Range Exhaust	25
Monitor Panel	26
TV Antenna/Jack.....	26
APPLIANCE MANUFACTURERS	27
SPECIFICATIONS	28

**AIRSTREAM, INC.
LIMITED WARRANTY
1993
190 MOTORHOME**

WARRANTY COVERAGE

When you buy a new AIRSTREAM ONE NINETY MOTORHOME from an authorized Airstream dealer, Airstream, Inc. warrants the motorhome from defects in material and workmanship as follows:

WARRANTY PERIOD

The warranty extends for a period of one year from the date of original retail purchase or 15,000 miles, whichever comes first.

ITEMS COVERED

Airstream covers all items used to convert the Ford Van to a Class B motorhome except the following items which are not covered:

- * Tires
- * Batteries
- * Fuses and Bulbs
- * Radio and Cassette Players
- * Microwave Oven
- * Generator

Ford has a Limited Warranty on their van that you should review with your local Ford dealership if you have any questions.

LIMITATION OF IMPLIED WARRANTIES

All warranties of merchantability and fitness for a particular purpose, whether written or oral, express or implied, shall extend only for a period of one year or 15,000 miles from the date of original purchase. There are no other warranties which extend beyond those described on the face hereof and expressly excludes conditions resulting from normal wear, accident, abuse, exposure or overload. Some states do not allow limitation on how long an implied warranty lasts, so the above limitation may not apply to you.

AIRSTREAM'S RESPONSIBILITY

The Airstream Limited Warranty applies for a period of one year or 15,000 miles from the date of original purchase, and the applicable date of all warranties is that indicated on the Owner's Identification Card. Defects in items covered under this warranty will be corrected without cost upon the return at the owner's expense of the motorhome or defective part to an authorized Airstream dealer.

CARE AND MAINTENANCE

This warranty covers only defective material and/or workmanship; adjustments and checking are excluded. All adjustments are made at the factory prior to shipment, and rechecked by the dealer prior to delivery to the customer. More detailed information is contained in the Explanation of Warranty.

The owner is also responsible for following all recommendations, instructions and precautions contained in the Airstream Owner's Manual and the individual manuals furnished by the appliance manufacturers.

INSTALLATIONS NOT COVERED

Airstream, Inc. cannot, however, and does not accept any responsibility in connection with any of its motorhomes for additional equipment or accessories installed at any dealership or other place of business, or by any other party. Such installation of equipment or accessories by any other party will not be covered by the terms of this warranty.

IF REPAIRS ARE NEEDED

If your motorhome needs repairs under the terms of the Airstream Limited Warranty, you should:

1. Take your motorhome to your selling dealer or other Authorized Airstream dealer.
2. If the dealer is incapable of making the repair, request that he contact the Service Administration Department at Airstream, Inc. for technical assistance.
3. If repairs are still not made, the customer should contact Airstream, Inc., 419 W. Pike Street, Jackson Center, Ohio 45334, Attention: Owner Relations Department and furnish the following information:
 - * The complete serial number of the motorhome.
 - * Date of original purchase.
 - * Selling dealer.
 - * Nature of service problem and steps or service which have been performed. (The owner may be directed to another dealer at the owner's expense.)
4. If, after taking the above steps, repairs are still not complete, the Airstream owner may request the motorhome be allowed to be brought to the Factory Service Center at the owner's expense.

DEALER REPRESENTATION EXCLUDED

The full extent of Airstream's Limited Warranty is set forth in detail in this folder, and in the Explanation of Airstream Limited Warranty covered in the Airstream Motorhome Owner's Manual. Airstream, Inc. will not be responsible for additional representations or implied warranties made by any of its dealers to the extent those representations are not a part of, or are contrary to, the terms and conditions of the Airstream Limited Warranty.

CONSEQUENTIAL AND INCIDENTAL DAMAGES

Airstream, Inc. will not be responsible for any consequential or incidental damages resulting from a defect. Incidental expenses include, but are not limited to, travel expenses, gasoline, oil, lodging, meals, telephone tolls, loss of work and loss of use of the motorhome. Some examples of consequential damages would be: stained curtains due to rain leaks or delaminated floor caused by a plumbing leak. Some states do not allow the exclusion or limitation of incidental or consequential damages, so the above limitation or exclusion may not apply to you.

WARRANTY TRANSFER

This limited warranty is transferable to subsequent owners for the duration of the warranty period. Warranty transfer application forms are available from your dealer or the Airstream, Inc. Service Administration Department.

CHANGES IN DESIGN

Airstream, Inc. reserves the right to make changes in design and improvements upon its product without imposing any obligation upon itself to install the same upon its products theretofore manufactured.

This warranty gives you specific legal rights, and you may also have other rights which vary from state to state.

Thor Industries
Airstream, Inc.
419 West Pike
Jackson Center, Ohio 45334

EXPLANATION OF AIRSTREAM LIMITED WARRANTY

The Airstream Limited Warranty is detailed in a separate folder. A plastic WARRANTY IDENTIFICATION CARD is sent to you after Airstream receives notification from your dealer of the sale. Since the I.D. card is necessary to obtain warranty it should be kept in the motorhome or on your person during the warranty period.

EXCLUSIONS

Normal Wear

Items such as tires, water purifier packs, curtains, upholstery, floor coverings, window, door and vent seals will show wear or may even wear out within the one year warranty period depending upon the amount of usage, weather and atmospheric conditions.

Accident

We strongly urge our dealers and customers to inspect the motorhome upon receipt of delivery for any damage caused by accident while being delivered to the dealer, or while it is on the dealer's lot. Damage of this nature becomes the dealer's or customer's responsibility upon acceptance of delivery, unless Airstream is notified and the damage is verified by the person making the delivery. Glass breakage, whether obviously struck or mysterious, is always accidental and covered by most insurance policies.

Abuse

Lack of customer care and/or improper maintenance may result in early failure for which Airstream cannot be held responsible.

Exposure

Not unlike a car, the steel parts can and will rust if subjected to prolonged exposure to moisture, salt air, or corrosive airborne pollutants without repainting. Aluminum oxidizes when unprotected under similar conditions, and refinery chemicals of a sulfurous nature are harmful to finishes if not washed off periodically. Extremely hot or direct sunlight will deteriorate rubber and fade curtains and upholstery. Conditions of this nature, although they may be normal for the area, are beyond Airstream's control and become the responsibility of the owner.

Although it is our obligation to correct a rain or plumbing leak within the terms of the limited warranty, it is the owner's responsibility to use reasonable, prudent care to minimize foreseeable secondary damage, such as a delaminated floor, stained upholstery, carpeting, drapes etc.

Overload

Damage due to loading, either beyond capacity or to cause improper handling because of improper balance, is beyond Airstream's responsibility.

MAINTENANCE SCHEDULE

WARNING: On new units check lug bolts every 200 miles for first 1000 miles.
Torque 9-95 ft. lbs.

EVERY 5,000 MILES OR 90 DAYS

G FI Circuit Breaker	Test and record.
LPG Regulator	Check bottom vent for obstruction.
Range Exhaust Hood	Clean fan blades and wash filter.
Roof Vent Elevator Screws	Lubricate with light household oil.

EVERY 10,000 MILES OR 6 MONTHS

Seals and Windows	Clean with mild detergent and coat with "Slipicone".
Exterior	Wax

CAMPING

SAFETY

As always, safety should be one of your top priorities. Make sure you, and everyone traveling with you, can operate all doors, and exit rapidly without light.

WARNING: **Read the directions carefully on the fire extinguisher. If there is any doubt on the operation, you and your family should practice, then replace or recharge the extinguisher. You will find your local fire department will be happy to assist you and answer any questions.**

WARNING: **Don't smoke in bed!**

Keep matches out of reach of small children!

Don't clean with flammable material!

Keep flammable material away from open flame!

We have all heard these warnings many times, but they are still among the leading causes of fires.

Other safety information on the LPG system of your motorhome is located in the Plumbing Section of this manual.

OVERNIGHT STOP

Airstream owners have parked virtually every place imaginable from filling stations to farm lands. In time you will develop a knack for spotting wonderful little roadside locations by turning off the main highway and exploring.

There are many modern trailer parks including State, County and Federal parks with good facilities where you may obtain hookups of electrical, water and sewer connections. Directories are published which describe in detail these parks and tell what is available in the way of services and hookups.

On overnight or weekend trips chances are you will not use up the capacity of the sewage holding tank, deplete the water supply, or run down the battery which supplies the 12 volt current. It's always a good idea to fill your water tank with "home water". There are some beautiful campgrounds with water you may find objectionable. The city water fill is on the curbside, behind the double door. Pull the plug out of the vent hole when filling.

On a longer trip, when you have stayed where sewer connections and utility hookups were not available, it will be necessary for you to stop from time to time to dispose of the waste in the holding tank and replenish the water supply. Many gas stations (chain and individually owned) have installed Sanitary Dumping Stations for just this purpose. Booklets are available which list these dumping stations.

When stopping for the night your Airstream is built to be safely parked in any spot that is relatively level and where the ground is firm. Your facilities are with you. You are self-contained.

Try to pick as level a parking spot as possible. Although your refrigerator may operate off level, the longevity of the cooling unit will decrease.

All you need to do to enjoy the self-contained luxury of your Airstream is to turn on the LP gas and light any appliances with pilots.

Before moving on, check your campsite both for cleanliness and also to be sure you haven't left anything behind. Turn off the gas supply and make sure everything is properly stowed.

EXTENDED STAY

For more than an overnight stay you will want to make use of hookup facilities provided at most campgrounds.

The power cord to plug into 110 volt service is located behind a small round access door on the roadside of your motorhome and close to the rear wheel. The cord pulls straight out.

WARNING: If an adapter is required, make sure the ground circuit is not by-passed.

Both the sewer hose hookup and city water connection are located on the roadside of your coach.

A storage compartment for sewer hose storage has been provided below the city water hookup. Always flush your hose thoroughly before storing.

Your water hose should be the type designed for stable water so there won't be any objectionable taste or odor.

For an extended stay you will want to make sure your motorhome is as level as possible. We don't recommend digging a hole to lower the high side. A sudden rainstorm may find you stuck in the rut you dug. An easier and better way is to carry along some short lengths of 3/4" and 2" boards about 8" wide. By using different combinations of thicknesses you will be able to level your vehicle in almost any circumstances you may find in a campground.

In cold weather it is normal for condensation to form. When one or more people spend any length of time in a small, closed area, humidity raises rapidly. Cooking and showers raise the content of moisture in the air even further, and it will condense on the coolest surface. To alleviate the problem you must provide ventilation. Barely cracking a window on each side, along with raising a roof ventilator, will normally be all that is necessary.

EXTERIOR

The exterior of your Airstream motorhome should be washed and waxed as any other automotive vehicle. However, there is one area where a little extra attention can save you a lot of time and labor later on. The front area of your motorhome is much larger than an automobile, and the amount of bugs that can be hit in a summer's evening, especially along waterways, can be astounding. A good heavy coat, or even a couple of coats, of paste wax can make their removal much easier. Bug removal after they have been soaked by a heavy dew or rain will also be easier.

Bugs will leave some marks. Some are caused by hard shells acting almost like a stone, whereas other bugs seem to have a corrosive action on paints and coating.

CAUTION:

Abrasive polishes or cleaning solvents, such as automatic dishwasher detergents or acid etch cleaners are too strong and should never be used.

As a general rule of thumb we recommend the unit be washed about every four weeks and waxed in the spring and fall. To make sure your new unit is always protected you should wax it immediately, or have your dealer wax it just prior to delivery. In industrial areas cleaning and waxing should be **done** on a more frequent schedule.

ALWAYS CLEAN YOUR MOTORHOME IN THE SHADE OR ON A CLOUDY DAY WHEN THE OUTSIDE SKIN IS COOL. Oil, grease, dust and dirt may be removed by washing with any mild non-abrasive soap or detergent. Cleaning should be followed by a thorough clean water rinse. Spots and streaks may be prevented by drying the unit with a chamois or a soft cloth.

It is important to remove sap, gum, resin, asphalt, etc. as soon as possible after they appear by washing and rewaxing. Sunlight and time will bake-harden these materials making them almost impossible to remove without heavy buffing. If asphalt remains on the unit after washing, use a small amount of kerosene on a rag and wipe the spots individually, being careful not to scratch the finish.

INTERIOR

All Airstream interiors have been designed for comfort, convenience, durability and appearance. How it is used and cared for naturally depends on you. Cleaning up spills immediately and preventing dust, dirt and grime from building up is a good starting point.

Dry Goods

The drapes and upholstery material should be routinely vacuumed with a soft brush attachment. Preventing dust and dirt from accumulating will add to the life of the materials.

If further cleaning is needed, the upholstery and curtain material **MUST BE DRY CLEANED**.

The drapes can be removed by taking out the screw and spacer in either end of the track.

Treat the hardwood furniture like any fine wood. Dust often, occasionally wax it, and it will reflect your care.

Carpet

The carpet can be cleaned with any good commercial carpet cleaner, or with a detergent and water. **BE CAREFUL NOT TO SOAK THE CARPET WITH WATER.**

Counter Area

The counter areas around the sink are of a high-pressure laminate, and can be cleaned with soap and water. Or you can use a common cleaning solvent on tough spots. Be sure no abrasive cleaner is used as there is the possibility it could scratch the surface. A protective pad should always be placed under hot utensils.

Stainless Steel Sink

Stainless steel sinks cannot be harmed by boiling water. However, salt, mustard, mayonnaise and ketchup can cause pitting. Stubborn stains will yield to paste made of water and slightly abrasive household cleaner. Be sure to work in the direction of the polish lines on the steel to keep the original finish. Fingerprints are sometimes a problem. They can be minimized by applying a cleaner that leaves a film of thin wax: Simply wipe it on and remove the excess with a dry cloth. After this, fingerprints can be wiped off with a soft dry cloth, or one moistened with a little wax cleaner. The surface should always be washed before wax is applied. Regular cleaning will prevent build-up of scale and film. Ordinary soaps or detergents are best for routine cleaning of the stainless steel sinks. Rinse thoroughly with warm water and wipe dry with a cloth to avoid streaks and spots.

PLASTIC BATHROOM COMPONENTS

CAUTION:

The shower pan in your bathroom is made of a special ABS long wearing, light weight, high strength plastic material. **WHEN CLEANING USE SOAP OR DETERGENT ONLY. NEVER USE SCOURING POWDER.**

Always re wax the ABS plastic surfaces after each heavy cleaning with a good grade paste wax (without solvents or cleaners). The wax will help protect the surfaces from discoloration and stains. When you first purchase your motorhome, Airstream recommends that you give all ABS plastic surfaces a heavy coating of paste wax. This will assure easier cleaning and lasting beauty.

Sofa

To convert the sofa into a bed, lift up on the front of the seat and pull out. The back rest will drop down automatically into place. To retract, again lift up on the front edge, push back toward the wall.

Bunk

To extend bunk, grasp facer board, lift and slide it back to the overhead cabinets. The facer board will drop into notches.

Table

The pedestal table used in your Airstream is commonly seen in all types of recreational vehicles. The pedestal table leg is usually stored between the front edge of the bunk mattress and the facer board. The pressure of the mattress holds it securely and prevents it from rattling.

To erect the table, first pull the carpeted center plug from the base • located directly in front of the couch. The tubing type table leg is tapered on each end. It is inserted into the base. The table leaf is then fitted over the leg. Both ends of the leg are tapered the same, so there is no up or down.

A slide assembly is used on the leaf so it can be moved closer or further away. Do not use force when erecting the table. The tapered legs fit the matching sockets well enough to make them become surprisingly tight. If stuck, a slight twisting motion will allow the leg to be withdrawn from the sockets.

WARNING: Always take the table down when traveling and store the leaf in the rear closet. In case of accident the heavy leaf can become a dangerous projectile.

Sliding Windows

Window latches are released when you pull in on the center vertical bar of the handle. Once released the windows slide in tracks. Just a light touch of Slipicone spray lubricant yearly will keep them sliding freely. Screens are cleaned by wiping with a damp cloth.

SMOKE DETECTOR

A smoke detector is centrally located in the ceiling of your motorhome.

The alarm horn and the indicator light on your detector lets you know whether your detector is working right.

When the indicator light, which you can see through the clear push button of the test switch, flashes once a minute, the detector is operating normally. (Model 83P has a white push button and does not flash.)

When the alarm is sounding the detector has sensed smoke or combustion particles in the air. The alarm will automatically turn off when the smoke in the air is completely gone.

If the alarm horn beeps once a minute the detector's battery is weak and needs to be replaced immediately.

How to take care of your detector.

Your smoke detector has been designed to be as maintenance free as possible. To keep your detector in good working order you must:

Test the detector regularly (weekly is recommended) by pressing on the test switch for up to 10 seconds until the alarm sounds. It is a good idea to test the detector after storage and before each trip. Make sure your family hears the detector and knows how to react.

Replace the battery once a year or immediately when the low battery "beep" signal sounds once per minute. The low battery signal should last at least 30 days.

This detector uses standard nine volt batteries. The detector will work properly with the following batteries.

Eveready #522, #1222, #216

Duracell #MNI604

Gold Peak #1604P, #16045

Eveready and Duracell batteries are available at any retail store that sells batteries.

WARNING: Do not use any other kind of battery. The detector may not operate properly with other batteries.

Vacuum the dust off the detector sensing chamber at least once a year. This can be done when you open the detector to replace the battery. Remove the battery before cleaning. Use a soft brush attachment and carefully remove any dust on the detector components, especially on the openings of the sensing chamber. Replace the battery after cleaning.

Clean the detector's cover when it becomes dirty. First open the cover and remove the battery. Then hand wash the cover with a cloth dampened with mild soapy water, rinse it with a cloth dampened with clear water, and dry it with a lint-free cloth. Be careful not to get any water on the detector components. Replace the battery and close the cover.

Test the detector after closing the cover whenever you have opened it to replace the battery or clean it.

CAUTION:

Do not paint the unit. Do not spray directly onto the unit any chemicals such as cleaners, air fresheners, hair sprays, insecticides, etc.

DO NOT DIRECT ANY FLAME OR OTHER INTENSE HEAT SOURCE AT THE UNIT.

THE PRESENCE OF DANGEROUS FUMES. The following steps should be taken immediately:

1. Extinguish all cigarettes and other open flames.
2. Have proper extinguisher ready.
3. Turn off all gas outlets and safety valves.
4. Use forced ventilation to reduce the concentration of gas or vapor level.
The alarm will stop when a safe level of fumes is reached.
5. Evacuate the area.
6. Call for professional help (Fire Department).

EXPLOSION AND FIRE PREVENTION IS SOUND COMMON SENSE. PUT IT INTO PRACTICE. PREPARE YOUR OWN SAFETY CHECK LIST AND FAMILIARIZE OTHERS WITH IT.

FIRE EXTINGUISHER

The fire extinguisher just inside your forward door should have the charge checked on a regular basis. Make sure your family, especially the cook, knows how to release the extinguisher storage bracket, and how to properly operate the extinguisher. If you find the directions on the extinguisher unclear, check with your local fire department. We're sure they will be happy to assist you and your family.

SAFETY:

Many things can be construed as safety related, but the most important is your common sense. If you are careless with matches, cigarettes, flammable material or any other hazardous material, we are sure you realize your potential for accident is greatly Increased.

PLUMBING

LPG SYSTEM

Your motorhome is equipped with a permanently mounted tank for LPG (Liquid Petroleum Gas). LPG burns with a clean blue flame. There are two basic types of LPG in common usage: Butane and Propane. Butane is widely used where temperatures are normally above freezing the year round, and Propane is used where subfreezing temperatures are common, since Butane freezes at 32° F as compared to -40° F for Propane. **ALL OF THE ORIFICES IN THE LPG APPLIANCES ARE OF THE UNIVERSAL TYPE WHICH WILL BURN EITHER FUEL.** How long a full tank of gas will last is dependent on usage. In cold weather, when you are using the furnace, large amounts of hot water, and cooking extensively, you will naturally use more than you will in warm weather when you may do limited cooking. On the average, with normal cooking and other appliance use, you can probably count on one month of usage from the tank.

If you have allowed the tank to run out, air may have gotten into the lines. In this event, the air must be forced out through the lines by gas pressure before you can light the pilots. Hold a match to the pilot of the appliance closest to the tanks until it lights and stays lit. Then move to the next closest, etc.

WARNING:

All pilot lights and appliances must be turned off during refueling of the motorhome fuel tank and permanently mounted LPG tank Gas lines should be checked periodically for leaks with ammonia free soapy water. Do not use open flame.

CAUTION:

Moisture in the LPG tank will cause a malfunction of the regulator in controlling proper pressure. This may result in the flame lifting off the burner, or the flame may go out frequently. Many refueling stations will add alcohol to your tank so the moisture will be absorbed and pass through the regulator.

WARNING:

If gas can be smelled, appliance pilots fail to stay on, or any other abnormal situation occurs, shut off tank valve immediately and call on a qualified LPG service center or Airstream Service Center.

LPG Regulator

The LPG regulators used on Airstream motorhomes are designed for low pressure service with a normal outlet pressure setting of 11.5" water column. Only personnel trained in the proper procedures, codes, standards, etc. should service regulators.

Have the regulator inspected each time the tank is refilled. Make sure the regulator vent opening on both first and second stage regulators does not become plugged by mud, insects, snow, ice, paint, etc. Vents must remain open.

Replace any regulator that has had water in the spring case, or shows evidence of external corrosion, or corrosion inside the spring case. Closely examine regulators directly connected to the container valve by means of a solid POL adapter (horizontal mounting) for signs of corrosion. (An Airstream Service Center is recommended for this service.)

BASIC RULES FOR SAFETY

WARNING: Do NOT store LP containers within vehicle. LP containers are equipped with safety devices that vent gas should the pressure become excessive.

WARNING: Do NOT use cooking appliances for comfort heating. Cooking appliances need fresh air for safe operation. Before operation open overhead vent or turn on exhaust fan and open window.

A warning label has been located in the cooking area to remind you to provide an adequate supply of fresh air for combustion. Unlike homes, the amount of oxygen supply is limited due to the size of the recreational vehicle, and proper ventilation when using the cooking appliances will avoid dangers of asphyxiation. It is especially important that cooking appliances not be used for comfort heating as the danger of asphyxiation is greater when the appliance is used for a long period of time.

WARNING: Portable fuel-burning equipment, including wood and charcoal grills and stoves, shall not be used inside the recreational vehicle. The use of this equipment inside the recreational vehicle may cause fire or asphyxiation.

WARNING: A Warning Label has been located near the LP gas container. This label reads: DO NOT FILL CONTAINER(S) TO MORE THAN 80 PERCENT OF CAPACITY. Overfilling the LP gas container can result in uncontrolled gas flow which can cause fire or explosion. A properly filled container will contain approximately 80 percent of its volume as liquid LP gas.

WARNING:

Do not bring or store LP gas containers, gasoline or other flammable liquids inside the vehicle because a fire or explosion may result.

WARNING:

IF YOU SMELL GAS:

1. Extinguish any open flames, pilot lights and all smoking materials.
2. Do not touch electrical switches.
3. Shut off the gas supply at the tank valve(s) or gas supply connection.
4. Open doors and other ventilating openings.
5. Leave the area until odor clears.
6. Have the gas system checked and leakage source corrected before using again.

WARNING:

LP gas regulators must always be installed with the diaphragm vent facing downward. Regulators that are not in compartments have been equipped with a protective cover. Make sure that regulator vent faces downward and that cover is kept in place to minimize vent blockage which could result in excessive gas pressure causing fire or explosion.

WATER SYSTEM—SELF CONTAINED

Fill the water tank by opening the exterior access door, remove screw cap and pull the vent plug. A garden hose can now be inserted. It's a good idea to let the water run through the hose for a short time to flush it out. Experienced RVers usually fill their tanks with "home" water to avoid strange water that may be distasteful to them.

The amount of water in the tank may be checked on the Monitor Panel, or you may fill the tank until water overflows out of the fill.

Open the hot side of the galley or lavatory faucet and turn on the water pump switch located on the monitor panel. For some time the open faucet will only sputter. This is because the water heater is being filled and air is being pushed out through the lines. Once the water heater is full a steady stream of water will come from the faucet. Now open a cold faucet. It will sputter for a short time, but will soon expel a steady stream. All other faucets can now be opened until all air is expelled.

Once the system is filled with water and the faucets closed, the water pump will shut off. When a faucet is opened the pump will come back on automatically. If the faucet is just barely open it is normal for the pump to cycle on and off rapidly.

CAUTION: The water pump must be turned off when hooked up to city water supply and when you leave your Airstream unattended.

WATER PUMP AND FILTER

The water pump filter is located in the bottom of the kitchen cabinet. The water pump is located in the bottom of the rear wardrobe.

The filter screen should be cleaned periodically to prevent accumulation of dirt and sand. To remove the screen, disconnect the rubber hoses from both ends, separate the screen housing, remove the screen, clean and replace.

WATER PUMP FILTER ASSEMBLY

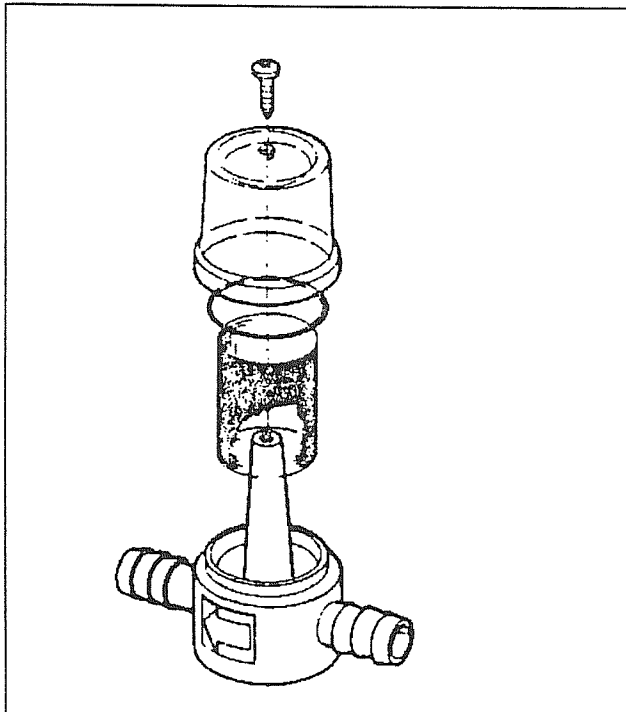

TO DISASSEMBLE PUMP FILTER

1. Remove screw through top.
2. Pull top from base. Do not damage "O" ring seal.
3. Remove screen to clean or replace.
4. Lift "O" ring from its cavity, lubricate with silicone grease.
5. Assemble by reversing above procedure.

Cleaning the Fresh Water Tank

To clean the tank pour some bicarbonate of soda into the filler spout with several gallons of water, and allow to stand for a minimum of four hours. Then flush the tank out by opening a faucet, allowing the water pump to drain the system. Then refill with fresh drinking water. If the water tank must be cleaned further the following procedure is recommended.

1. Prepare a sodium hypochlorite solution using potable water and household bleach (5 1/4 to 6%) in a ratio of 1/4 cup of bleach to one gallon of water. (Common household bleaches are Purex and Chlorox.)
2. Pour 1 gallon of hypochlorite solution for each fifteen gallons of capacity into the empty water tank.
3. Add enough potable water to completely fill the water system.
4. Allow closed system to stand for three hours.
5. Drain the hypochlorite solution from the system and refill with potable water.
6. Excessive hypochlorite taste or odor remaining in the water system is removed by rinsing the system with a vinegar solution mixed in a ratio of 1 quart of vinegar to 5 gallons of water.
7. Drain the system and flush with fresh drinking water.
8. Drain the system and refill with fresh drinking water.

NOTE: The tank drain valve is located under the forward end of the galley in the part that extends slightly over the step of the double side door. If you stand outside and open the double side door you will be able to feel the valve under the corner of the galley cabinet.

CITY WATER HOOK-UP

The city water hook up is on the left (roadside) of the vehicle behind the rear wheel well.

Use a high pressure hose of at least 1/2" diameter. It should be one that is tasteless, odorless and non-toxic designed for RV use. The city Water inlet is a standard garden hose thread. We suggest you carry two lengths of hose. This way you have the ability to reach hook ups farther away than normal, plus you have a spare hose should one fail or become damaged unexpectedly.

After hooking up the hose **and** turning on the city water valve provided in the park, slowly open a faucet. There will be a lot of spurts and sputtering until all the air is expelled from the system. If the water heater is empty it will take some time before all the air is expelled and you get a steady flow of water at the faucet. Once a steady flow is achieved at one faucet the others should be opened long enough to expel the air in the lines going to them

During city water operation the water pump switch should be in the off position. A check valve built into the pump protects it from city water pressure.

WINTERIZING AND STORAGE

When storing your motorhome for short or long periods use the same precautions as you would in your own home with regard to perishables, ventilation and rain protection. In addition, for prolonged storage periods, flush out all the drain lines and the holding tanks. Also drain the entire water system including the water heater and the water storage tank. Instructions for draining the water system are explained in the following paragraphs on winterizing.

THE MAIN CONSIDERATION IN WINTERIZING IS TO GUARD AGAINST FREEZING DAMAGE TO THE HOT AND COLD WATER SYSTEMS, THE WASTE DRAIN SYSTEM INCLUDING THE TRAPS), THE WATER HOLDING TANKS, THE WATER HEATER AND THE BATTERY.

WINTERIZING PROCEDURES

1. Open faucets and prop toilet open.
2. Open all drain valves.
 - a. *Water tank*: Under corner of kitchen cabinet—access through side double door.
 - b. *Cold water line drain*: Access through cabinet when curbside rear double door is open.
 - c. *Hot water line drain*: Access through cabinet when curbside rear double door is open..
 - d. *Water heater*: Drains out plug on the lower face of water heater
3. After water quits draining shut valves.
4. Attach a length of hose to the intake side of water pump and insert into RV antifreeze container. This may be diluted. Follow directions on container.
5. Turn pump on and operate until antifreeze is apparent at all faucets and the toilet.
6. Pour a cup of the RV antifreeze down each sink and shower drain.
7. Dump holding tanks.
8. Remove batteries and store where there is no danger of freezing. Bring up to full charge about every six weeks with a trickle charger.
9. Remove any items from unit that may be damaged by freezing, such as canned goods and cosmetics.

Note: If you wish to bypass your water heater in order to cut down on the amount of antifreeze necessary, you may purchase a kit for this purpose from your dealer.

DRAIN AND WASTE SYSTEMS

Your motorhome is equipped with two holding tanks. One is for *grey* water, which is shower and sink waste water; the other is for *black* water, which is toilet sewage. When dumping, drain the black water first, then the grey water; in this way, the grey water will help flush black water residue from the sewer hose.

CAUTION:

Never put wet strength paper towels or tissues in your holding tank since they won't dissolve and can "catch" in the mechanism of the dump valve. Colored toilet tissue is slower to dissolve than white. Most RV accessory stores offer tissue designed for RVs that will completely dissolve.

DEODORIZERS

There are many deodorizers on the market in tablet, liquid and powder form. These not only combat odor, but stimulate the bacteria that works to dissolve the solids in your tank.

On your monitor panel "HOLDING TANK 1 and 2" are used on the drain system. You should check frequently to avoid overfilling. An overfilled tank will back up and leave an unpleasant cleaning job, to say the least.

EMPTYING TANKS

Almost all campground will have dumping facilities. Park directories such as Woodalls and Rand McNally also list dumping stations.

To empty the tank attach the sewer hose by pressing the bayonet fitting onto the dump valve outlet and rotate clockwise until it feels solid and secure. Attach the outlet end of the hose to the sewage outlet, making sure that the hose is placed so it will drain completely.

Pull the dump valve handle as far as it will go and wait until the tank is drained. The holding tank must be flushed out until all paper and waste material is removed. Close the dump valve and refill the tank with clean water and repeat until clean. Repeat the same step with grey water. Replace the cap prior to traveling.

WHEN PARKED AND CONNECTED TO SEWER OUTLET

When you are in a park and connected to a sewer outlet keep the holding tank dump valve closed, and empty the tank whenever it becomes almost full. **ONLY BY SENDING A LARGE VOLUME OF LIQUID THROUGH THE HOLDING TANK AT ONE TIME WILL TOILET PAPER AND OTHER SOLIDS COMPLETELY WASH AWAY.**

This practice will avoid the accumulation of solids in the holding tank which could lead to an unpleasant cleaning job. Should solids accumulate, close the dump valve, fill the tank about half full with water, then drive for a few miles. The turbulence and surging of the water will usually dissolve the solids into suspension so the tank can be drained.

Draining the tank as described will protect it from freezing during storage. When traveling in sub-freezing temperatures use a winterizing solution designed for RV use. Follow the directions on the container.

WATER PUMP

Manufacturer: Shur-Flo
1740 Markle Street
Elkhart, Indiana 46514
Phone: 219-294-7581

The switch for the water pump is located on the monitor panel. Before turning it on make sure your fresh water tank is full.

To operate, turn the pump switch on and open the hot side of a faucet. It is normal for the faucet to spit and sputter prior to getting a full stream of water. If the system has been drained, this may take a few minutes since the pump is forcing water into the water heater and a solid stream of water won't be obtained until the water heater is completely filled.

Once you have a full stream of water on the hot side, turn it off and open the cold side. You will get the same spit and sputter, but only for a few moments as air is being purged. Repeat with the other faucets and the toilet so the air is all purged.

Now when the faucets are all turned off the pump will quit running automatically. Whenever a faucet is opened the pump will run until the faucet is closed. If a faucet is only open a small amount the pump will cycle rapidly on and off. This is not harmful to the pump.

The pump switch should be turned off when the motorhome is unattended.

Properly Installed, the Pump Will:

Prime: The pump will automatically prime itself.

Air-Lock: Pump will not air-lock as the compression stroke is powerful enough to pressurize the entrapped air and force the check valve open.

Run Dry: Pump will run dry for extended periods without damage.

Battery Drain: At free flow the pump draws a mere 7 to 7 1/2 amps.

Check Valve: Built-in neck valve prevents back-flow and can protect the pump from the dangers of high city water pressure (up to 200 PSI.)

Fully Automatic: The pump will automatically come on when the faucet or valve is opened. It delivers a smooth steady flow of water and shuts off automatically when the faucet is closed.

TROUBLE SHOOTING

Motor does not operate.

- Is battery discharged?
- Are any wires disconnected?
- Are terminals corroded?
- Is switch in "ON" position?
- Is fuse good?
- Is water frozen in pump head?

Motor runs but no water flows.

- Is water tank empty?
- Are there kinks in the inlet hose?
- Is air leaking into inlet hose fittings?
- Is inlet line or in-line filter plugged?
- If using a filter, check the line just before the filter.
- Is outlet hose kinked?

Motor runs but water "sputters".

Check to be certain that air has been bled off the lines and water heater. Also check for air leaks in the input side of the pump.

Pump cycles on and off when all outlets are closed.

The pump will normally cycle (go on and off) when a faucet is partially opened. If, however, it cycles when all valves are closed, check for a leak in the lines. It may be a leaky toilet valve or a dripping faucet. Do not forget to check the outside city water entry valve. It may be leaking.

If no leak can be detected, shut pump off. Remove the output hose where it joins the system (not at the pump). Insert a plug in the hose and clamp it. (You can make a perfect plug from a barb fitting, 1/2" size with a cap tightly screwed on the threads.) Turn the pump off. If it remains off, the problem is NOT the pump. The problem is in the system. If, however, the pump goes on and off there may be a problem in the pump.

There may be an internal leak in the pump which allows water to escape from the high pressure area back into the low pressure area. Look for a pump valve held open or a crack in the plastic parts.

Pump does not achieve shut off.

The wall switch may be used for temporary control of the pump. A low battery charge may be the cause. Or the pump switch mechanism may be stuck. Try tapping the switch cap on the end of the pump with the handle of a screwdriver. If the pump appears in all other respects to run normally, but fails to shut off, you may have to replace the switch mechanism.

Pump head leaks.

If the pump head leaks, first try to tighten the screws in the pump head assembly until they are snug.

CAUTION: Do not over tighten. The leak may be from a crack in the pump head assembly. If so, then replace.

One cause of the pump head cracking may be water freezing inside the pump head. If the leaking water is escaping back near the motor, check for a leaking or broken piston.

TOILET

Manufacturer: Thetford Engineering
P.O. Box 1285
Ann Arbor, MI 48106
313-769-6000

OPERATION

To flush, press down on foot pedal until water swirls, then release. A short delay between pressing the lever and getting a good swirl is to be expected. This delay is used to build up an internal water supply which insures a proper bowl refill, required for odor control, after the lever is released.

MAINTENANCE

No routine maintenance is required. To clean the unit use Thetford Aqua Bowl or any other high grade, non-abrasive cleaner. Do not use highly concentrated or high acid content household cleaners. (No scouring powder.)

WINTERIZING

1. Draining Method.
Completely drain the toilet water supply line leaving the water supply valve open. This valve may be kept open by inserting a suitable object into the flush hole in the bowl. (Caution: When using air pressure to drain water line, toilet valve should be held in open position.)
2. Antifreeze Method.
Use recreational vehicle type antifreeze to winterize the fresh water plumbing system. (Caution: Never use automotive type antifreeze in fresh water system. These are highly toxic.)

Note: If water is inadvertently frozen in the toilet, do not attempt to flush until the ice is thawed. Otherwise damage to toilet could occur.

TROUBLE SHOOTING

Symptom: Water keeps running into the bowl.

Cure: Check to see that the lever closes all the Way. Sticking may be caused by foreign material in the bottom of the bowl.

If water running persists, and the lever works satisfactorily, replace the ball valve. (Part #08881.) This is accomplished by removing the lever, disconnecting the water line, and removing the two 5/8" long screws on either side of the base of the ball valve stem, and the 1/2" long screw which is accessible through the hole in the toilet base. Pull down on the valve to remove. When installing the new ball valve, make sure the #08903 seal is in place on the exit end of the valve before the valve is screwed in place.

Symptom: Toilet leaks. There is water on the floor.

Cure: If the leak is in the back of the toilet, check the water supply line connection, and refer to the installation instructions.

If the leak is at the closet flange area, check the closet flange nuts for tightness. If leak continues, remove the toilet and check the closet flange height. The height should be between 1/4" and 7/16" above the floor. Adjust accordingly and replace the closet flange seal if damaged.

Symptom: Poor flush.

Cure: The lever must be held fully open during the flush. A good flush should be obtained within five seconds.

If the problem persists, remove the water supply line and check the water supply. The water supply line flow rate should be at least eleven quarts per minute to ensure an adequate flush.

ELECTRICAL

OPERATION

The lights and appliances in your motorhome are operated by 12 volt D.C. current. This means the charge of your battery is important to the operation of the vehicle.

The battery is charged from two different sources. When you drive, current is supplied to the coach battery from the alternator and through the solenoid. The electric current can flow from the alternator to the coach battery, but once the ignition key is turned off the circuit is broken. This prevents you from accidentally running down your engine battery if you leave an interior light on or fan running.

The second method of charging your coach battery is through the 110 volt converter when you are plugged into city power. If we call the converter an automatic battery charger it is easier to understand. The converter not only charges the battery, but will also provide "load" current at the same time.

Note: It should be noted if you are driving or plugged into 110 volt current the monitor panel battery condition meter will be sensing the charging voltage and not the actual battery status.

The converter is located under the end of the couch toward the front. If you turn the latch and open the door you will discover more features of the converter.

You will not only see the automotive type fuses for the 12 volt Wiring, but you will also find the 110 volt circuit breakers.

The 110 volt circuit breakers perform the same function as the circuit breakers or fuses in your home. If an overload or short circuit occurs the circuit breaker kicks out, preventing damage to the wire or a fire.

It is normal for a breaker to occasionally kick off for what seems no reason. Just turn it to the off position then back on and it will be reset. If it kicks back off in a few minutes the circuit is probably overloaded and it will be necessary fir "ill to reduce the number of appliances or lights on that particular circuit.

WARNING: If the breaker kicks off immediately after resetting it is an indication of a shorted circuit in the wiring or appliances operating on that circuit. DO NOT continue to reset the breaker. Have an experienced service technician check and correct the problem.

The 12 volt fuses are located next to the 110 volt breakers. They are the small ATC type used by many automobile manufacturers (GM). They are readily available at most service stations and all automotive stores.

The two digit number on the top of the fuse indicates its amperage rating.

CAUTION: When replacing fuses always make sure the amperage rating of the new matches the old.

ATC type fuses are removed by pulling them straight out of the converter. Normally this can be done with your fingers, but if one is tight the plastic head of the fuse can be gripped with pliers to aid removal.

As viewed from the side, an inverted “U” is visible through the plastic. If the fuse is blown the inverted U will be melted out across the top. See Illustration.

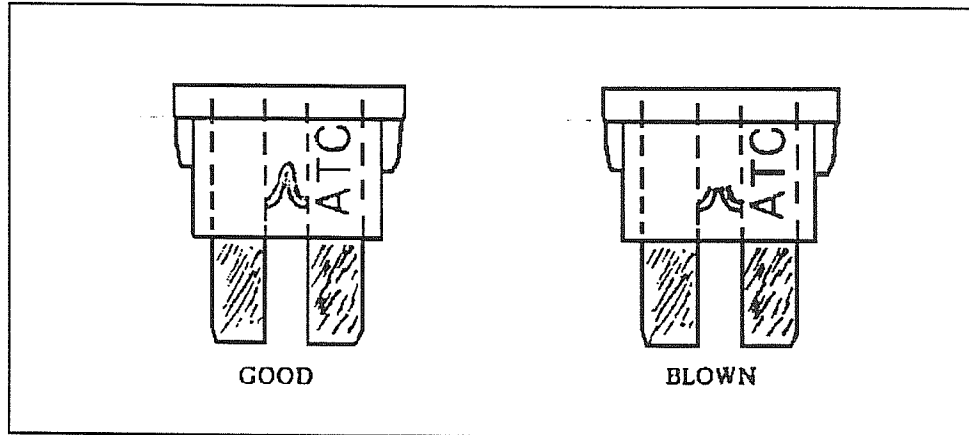

The 12 volt system provides power to the lights, fans, appliances, pump and monitor panel.

LIGHTS

The lights all have switches adjacent to them, plus a remote switch on the bunk lights. The remote switch is located in the forward end of the overhead cabinet on the driver's side. You will appreciate it the first time someone crawls down out of the bunk and forgets to turn the lights off.

Access to the bulbs is gained by squeezing the lens until they are free of the base. The fluorescent bulbs are removed by giving them a quarter turn and pulling straight out. Filament type bulbs must be depressed slightly then twisted counterclockwise about one quarter turn to remove. Bulbs are available from your dealer or many camping stores.

ROOF VENTS

Some of the roof vents include a 12 volt fan. The fan should not be operated for long periods of time without the vent cap being opened at least a small amount.

There is no regular maintenance required. If any new parts are ever needed they are easily changed.

The vents have been installed so the side of the cap that raises is toward the rear of the motorhome. This allows you to leave them partially open when you travel. RVers have argued for years about driving with the vents partially open. Some say the vents exhaust hot air when they are driving so the motorhomes aren't stuffy. Others say the vents cause a vacuum in the unit and tend to suck in dust.

RANGE EXHAUST

The range exhaust has two switches. One for the fan blower motor, and the second for a light. The filter should be washed on a regular basis according to usage. Sliding the filter toward the outside wall will allow the front edge to come down out of the frame. Soak the filter in dish water and let it air dry.

To change the 12 volt light bulb (#912) slide the lens down and it will come free from the frame. The bulb pulls straight out of the base.

MONITOR PANEL

The Jensen Micro Monitor panel is used so you can easily tell how much water is in your tanks, the level of your LPG tank, holding tank levels and the state of charge of the coach battery.

Included on the panel is the water pump switch. Information on water pump operation is included in the plumbing section of this manual.

The switch directly below the monitor panel is for the electronic ignition Atwood water heater. When the switch is depressed the red light will flash until the burner is ignited or the "try" cycle is completed. If the water heater hasn't been used for a while it is normal for a few cycles to be required since air in the gas line will have to be purged.

TV ANTENNA/JACK

Above the refrigerator is the TV jack. It has two receptacles. The largest is for a standard 12 volt accessory plug. The small is for hookup of coaxial TV cable for the antenna.

Your TV antenna is built into the roof luggage rack. It is non directional, so no maintenance is required.

CAUTION: Drilling holes or otherwise attempting to alter the luggage rack may be detrimental to reception.

APPLIANCE MANUFACTURERS

CONVERTER	B-W Manufacturers, Inc. 721 North Webster Street Kokomo, Indiana 46901 317-452-5444	Model 6332
FURNACE	Hydro Flame Corporation 1874 South Pioneer Road Salt Lake City, Utah 84104 800-825-4382	Everest. Star FA7912
RANGE	Wedgewood Industries, Inc. P.O. Box R Greenbrier, Tennessee 37073 615-643-4556	2 Burner
REFRIGERATOR	Dometic Sales Corporation 2320 Industrial Parkway P.O. Box 490 Elkhart, Indiana 46514 1-800-443-3324 or 219-295-5228	Model 2310
WATER HEATER	Atwood Vacuum Machine Company 1400 E. Eddy Avenue Rockford, Illinois 61101 815-877-7461	G6A-6E
TOILET	Thetford Engineering P.O. Box 1285 Ann Arbor, Michigan 48106 800-521-3032	Model SKU20820
WATER PUMP	Shur Flo 1740 Markle Street Elkhart, Indiana 46514 800-854-3218	Model 120
GENERATOR	Onan 1400 73rd Avenue N.E. Minneapolis, Minnesota 55432 612-574-5000	Microlite 2.8KV-FA/26100
AIR CONDITIONER	The Dometic Corp. The Warranty Dept. 509 South Poplar St. LaGrange, IN 46761 800-544-4881	Model 600312.304

SPECIFICATIONS

14760

Dry Weight	6,920	Lbs.	
GVWR	9,300	Lbs.	
GCWR	15,000	Lbs.	(7.5L Engine)
GCWR	11,500	Lbs.	(5.8L Engine)

Height	9'6"		
Width	6'8"		
Length	19'8"	(with spare)	

Fuel	35	Gal.	(Mid-Ship)
LP Tank	9.8	Lbs. GAL.	
Fresh Water Tank	22	Gal.	
Grey Holding Tank	20	Gal.	
Black Holding Tank	21	Gal.	

Note: All figures were taken from a prototype vehicle. The actual figure of your vehicle may vary slightly.

NOTES

NOTES

A&E HORIZON MODEL
 12' BLUE

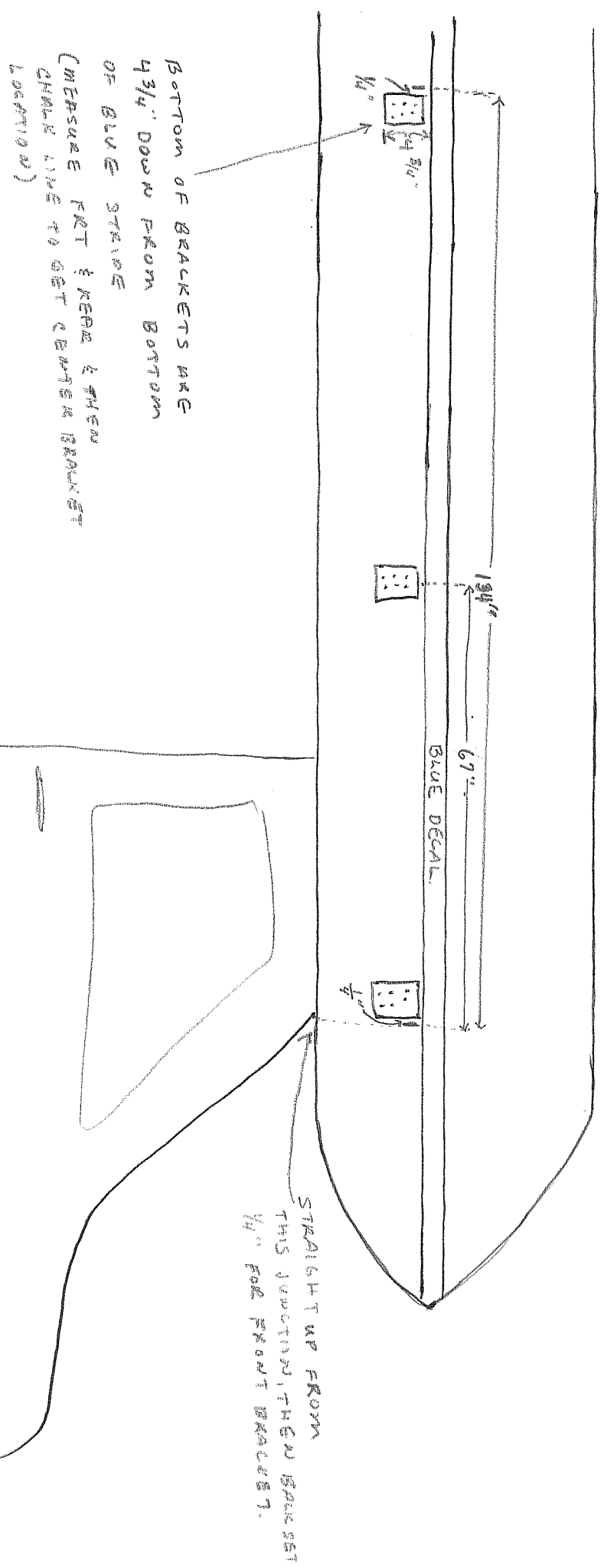
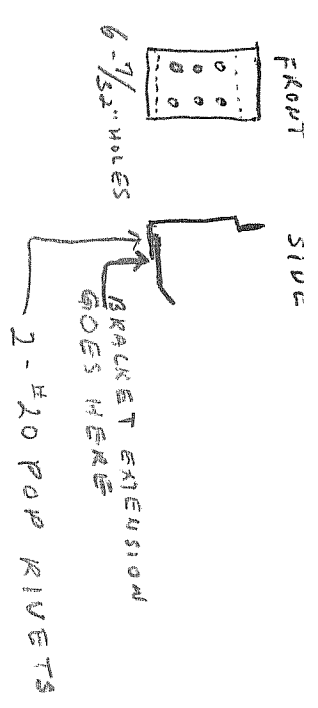

Side



FRONT



① Drill hole in 7/32 hole's bracket bit before you put BRACKETS ON.

② PAGE

③ (7/32 bit.)
When you drill thru Alum metal STOP Drilling!

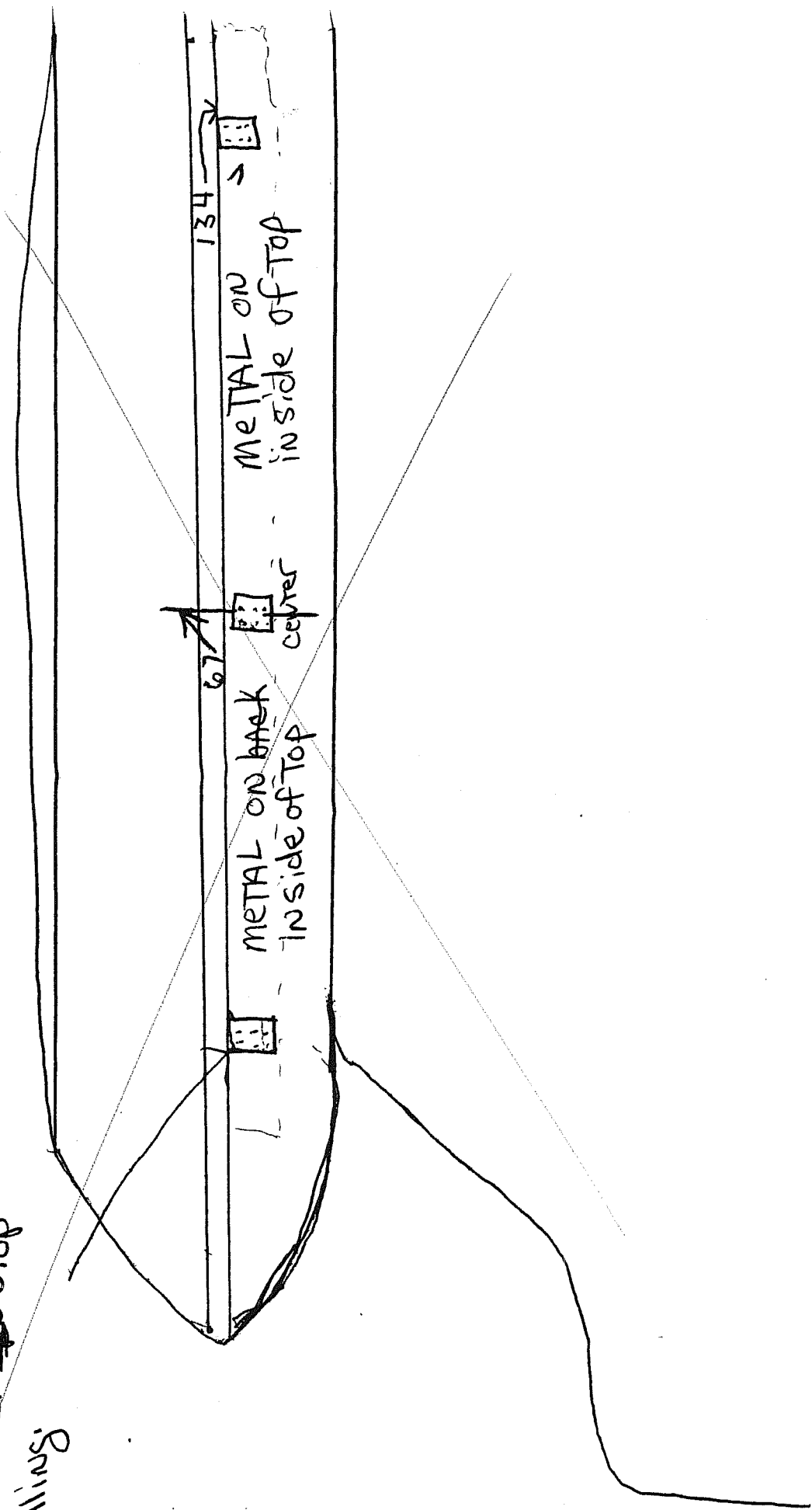

AWNING HANGS
FROM TOP OF BRACKET

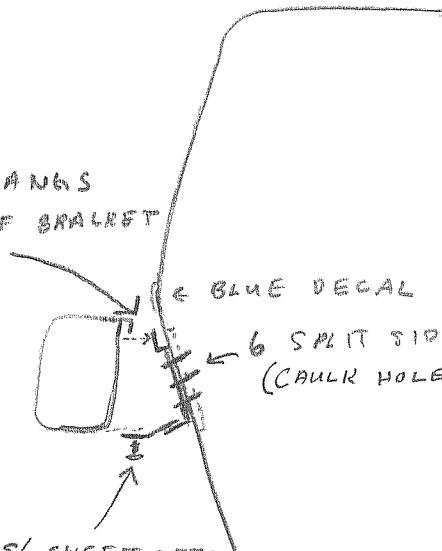

← BLUE DECAL

← 6 SPLIT SIDE RIVETS
(CAULK HOLES BEFORE INSTALLING)

← 2 8x3/4 5/8 SHEET METAL

SCREWS FROM BOTTOM
UP HOLD AWN. IN VERT
POSITION.

③ page

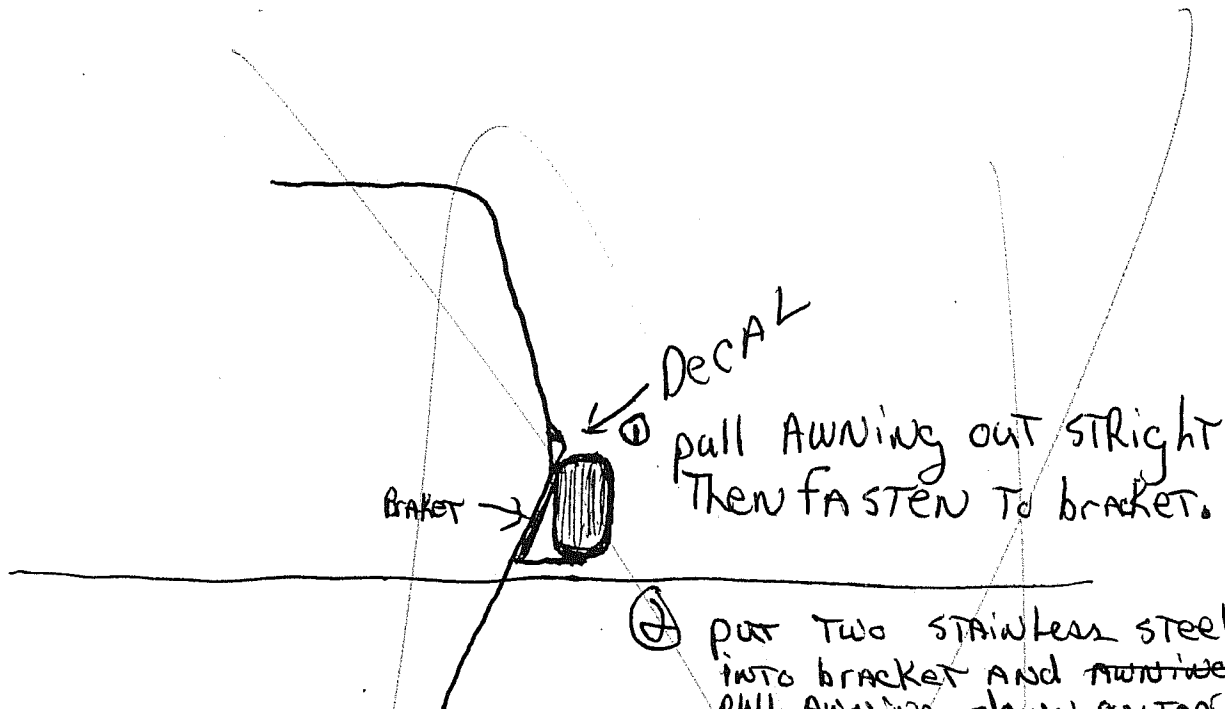

① pull AWNING out STRIGHT
THEN FASTEN TO BRACKET.

② put two STAINLESS steel screws
into bracket and ~~moving~~ Then
pull AWNING down on top of
The Bracket Lip Then Tighten
AWNING down.

③ Go to The other End
of AWNING and do The
SAME Thing.

4 Then go to center
BRACKET adjust it
to where you WANT it
THEN FASTEN AWNING +
BRACKET TOGETHER.

AEE HORIZUM
12' BLUE

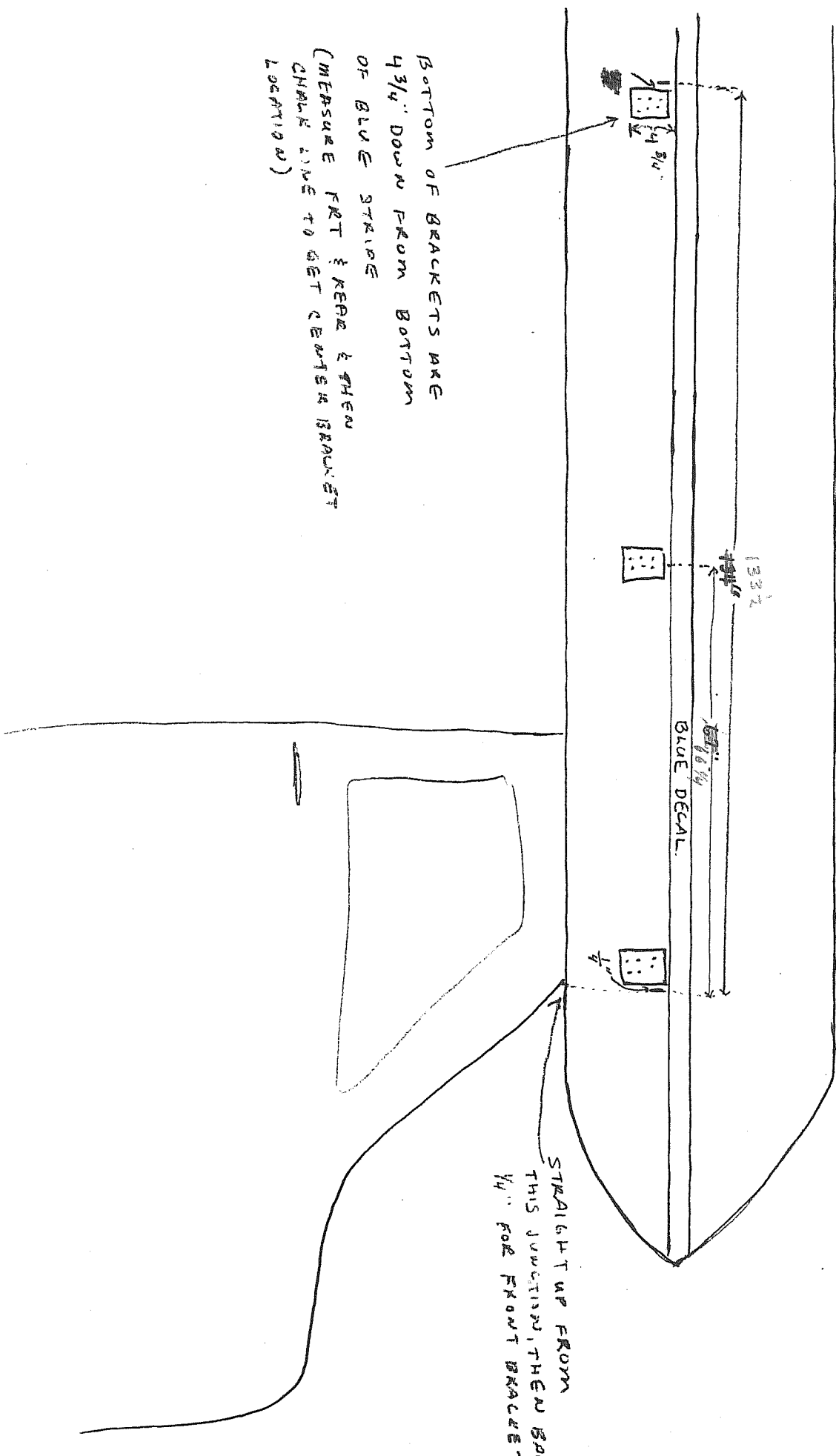

BOTTOM OF BRACKETS ARE
4 3/4" DOWN FROM BOTTOM
OF BLUE STRIPES
(MEASURE FRT & REAR & THEN
CHALK LINE TO GET REMAINING BRACKET
LOCATION)

STRAIGHT UP FROM
THIS JUNCTION, THEN BACK SET
1/4" FOR FRONT BRACKET.

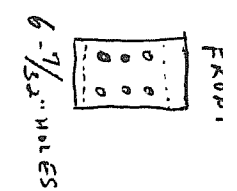

BRACKET EXTENSION
GOES HERE
2 - #20 POP RIVETS
PN 682632

AWNING HANGS
FROM TOP OF BRACKET

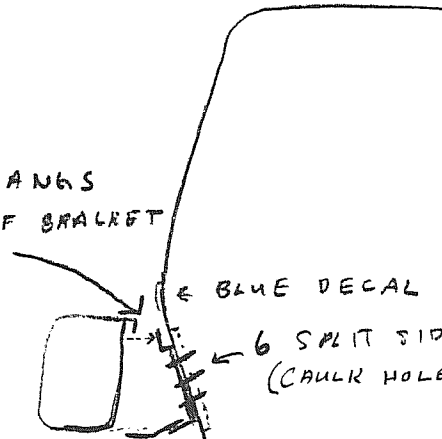

← BLUE DECAL

← 6 SPLIT SIDE RIVETS
(CAULK HOLES BEFORE INSTALLING)

← 2 5/8 SHEET METAL

← SCREWS FROM BOTTOM
UP HOLD AWN. IN VERT
POSITION.

