

1993

OWNER'S MANUAL

LAND YACHT *PUSHER* *By Airstream*

#####

*1000 Mile Check or 60 Day Check-Out

AUTHORIZATION CARD

This card entitles you, under the exclusive Airstream Certified Performance Checkout Program, to a 1000 mile (or 60 day . . . whichever comes first) Performance Check of your Airstream Land Yacht Motorhome.

*After delivery of your motorhome.

#####

INTRODUCTION

The Owners Manual for your new Airstream Land Yacht Motorhome is designed to explain the operation, function and care of the many systems that make modern motorhoming a joy.

Airstream realizes our customers possess varying degrees of expertise in the area of repairing and maintaining the appliances in their motorhome. For this reason, the service and trouble-shooting information found in this manual is directed toward those with average mechanical skills. We also realize you may be more familiar in one area than you are in another. Only you know your capabilities and limitations.

We want you to use this manual, and hope you will find the information contained in it useful; however, should you ever feel you may be "getting in over your head" please see your dealer to have the repairs made.

The operation and care of component parts such as chassis, refrigerator, furnace, water heater and others are explained in this manual. However, you will also find manufacturer's information supplied in a packet included with this manual.

All information, illustrations and specifications contained in the literature is based on the latest product information available at the time of publication approval.

Throughout this manual **CAUTION** and **WARNING** notations are used. Failure to observe "caution" can damage equipment. "Warning" notes the possibility of personal injury if not observed.

Note: If and when new materials and production techniques are developed which can improve the quality of its product, or material substitutions are necessary due to availability, Airstream reserves the right to make such changes.

TABLE OF CONTENTS

A. WARRANTY AND SERVICE

Warranty
Warranty Explanation
Service
Reporting Safety Defects
Maintenance Schedule

B. DRIVING

Safety Check List
Dash Controls & Instruments
Trailer Towing & Driving Tips

C. CHASSIS

Components
Dash Heater/Air Conditioner
Windshield Wiper
Step

D. CAMPING

Camping Safety
Overnight Stop
Winter Traveling
Extended Stay

E. EXTERIOR

Cleaning
Windows/Doors

F. INTERIOR FURNISHINGS & ACCESSORIES

Lounges & Tables
Fabric Care
Features & Fixtures

G. PLUMBING

LP (Liquid Petroleum) Gas
Water System
Water Pump
Water Filter
Faucets
Drainage System
Toilet

H. ELECTRICAL

Battery
12 Volt system
Monitor Panel
Antennas
110 Volt System

I. APPLIANCES

Air Conditioner
Furnace
Refrigerator
Range/Oven
Water Heater
Power Roof Vent

J. SPECIFICATIONS

AIRSTREAM, INC.

LIMITED WARRANTY

AIRSTREAM LAND YACHT MOTORHOME

Warranty Coverage

When you buy a new Airstream Land Yacht Motorhome from an authorized Airstream dealer, Airstream, Inc., warrants the motorhome from defects in material and workmanship as follows:

Warranty Period

12,000 miles (20,000 Kilometers) or one year, whichever occurs first, beginning when the vehicle is delivered to the first retail purchaser or first placed into demonstrator service. This warranty must have been started prior to the accumulation of 4,000 miles in order to be valid.

Items Covered

Any part of the motorhome or any component equipment installed by the factory is covered by the warranty except the following items which are not covered:

- * Spartan Chassis
- * Battery
- * Fuses and Light Bulbs
- * Video Recorder
- * TV and Radio
- * Backing Monitor
- * Microwave Oven
- * Tires
- * AC Power Plant

The above items will be handled by their respective service points and according to their written policy. This limited warranty does not include failure caused by accident, abuse, normal wear, overload or any cause not attributable to a defect in original material or workmanship of the motorhome or component equipment as installed by the factory.

Limitation of Implied Warranties

All warranties of merchantability and fitness for a particular purpose, whether written or oral, express or implied, shall extend only for a period of one year from the date of original purchase, or 12,000 miles, whichever comes first. There are no other warranties which extend beyond those described on the face hereof and expressly excludes conditions resulting from normal wear, accident, abuse, exposure or overload. Some states do not allow limitation on how long an implied warranty lasts, so the limitation may not apply to you.

Airstream's Responsibility

The Airstream Limited Warranty applies for a period of one year from the date of original purchase, or 12,000 miles, whichever occurs first, and the applicable date of all warranties is that indicated on the Owner's Identification Card. Defects in items covered under this warranty will be corrected without cost upon the return at the owner's expense of the motorhome or defective part to an authorized Airstream dealer.

Care and Maintenance

This warranty covers only defective material and/or workmanship; adjustments and checking are excluded. All adjustments are made at the factory prior to shipment, and rechecked by the dealer prior to delivery to the customer. Adjustments thereafter become a customer responsibility.

The owner is also responsible for following all recommendations, instructions and precautions contained in the Airstream Owner's Manual and the individual manuals furnished by the chassis, appliance and other manufacturers.

Installations not Covered

Airstream, Inc., does not accept any responsibility in connection with any of its motorhomes for additional equipment or accessories installed at any dealership or other place of business, or by any other party. Such installation of equipment or accessories by any other party will not be covered by the terms of this warranty.

If Repairs are Needed

If your motorhome needs repairs under the terms of the Airstream Limited Warranty, you should:

1. Take your motorhome to your selling dealer or other Authorized Airstream dealer.
2. If the dealer is incapable of making the repair, request that he contact the Service Administration Department at Airstream, Inc., for technical assistance.
3. If repairs are still not made, the customer should contact Airstream, Inc., 419 W. Pike Street, Jackson Center, Ohio 45334, Attention: Owner Relations Department, and furnish the following information.
 - * The complete serial number of the motorhome
 - * Mileage
 - * Date of original purchase
 - * Selling dealer
 - * Nature of service problem and steps or service which have been performed. (The owner may be directed to another dealer at the owner's expense.)
4. If, after taking the above steps, repairs are still not complete, the Airstream owner may request the motorhome be allowed to be brought to the Factory Service Center at the owner's expense.

Dealer Representation Excluded

The full extent of Airstream's Limited Warranty is set forth in detail in this folder, and in the Explanation of Airstream Limited Warranty covered in the Airstream Motorhome Owner's Manual. Airstream, Inc., will not be responsible for additional representations or implied warranties made by any of its dealers to the extent those representations are not a part of, or are contrary to, the terms and conditions of the Airstream Limited Warranty.

Consequential and Incidental Damages

Airstream, Inc., will not be responsible for any consequential or incidental expenses or damages resulting from a defect. Incidental expenses include, but are not limited to, travel expenses, gasoline, oil, lodging, meals, telephone tolls, loss of work and loss of use of the motorhome. Some examples of consequential damages would be: stained curtains due to rain leaks or delaminated floor caused by a plumbing leak. Some states do not allow the exclusion or limitation of incidental or consequential damages, so the above limitation or exclusion may not apply to you.

Warranty Transfer

This limited warranty is transferable to subsequent owners for the duration of the warranty period. Warranty transfer application forms are available from your dealer or the Airstream, Inc., Service Administration Department.

Changes in Design

Airstream, Inc., reserves the right to make changes in design and improvements upon its product without imposing any obligation upon itself to install the same upon its products theretofore manufactured.

This warranty gives you specific legal rights, and you may also have other rights which vary from state to state.

Thor Industries
Airstream, Inc.
419 West Pike
Jackson Center, Ohio 45334

WARRANTY EXPLANATION

Along with your new Airstream motorhome you have purchased the Airstream Limited Warranty. Read your Limited Warranty carefully. It contains the entire agreement with respect to Airstream's obligation on the Limited Warranty on your new vehicle. The terms of the Limited Warranty, and only those terms, will define Airstream's responsibility. When you receive your Limited Warranty file it for safekeeping.

Upon proof of purchase date to any Airstream Dealer Service Center, defects in materials or workmanship will be repaired or replaced without cost to the owner for a period of twelve (12) months from the original purchase date, or 12,000 miles, whichever occurs first. Written warranties of some manufacturers of components of the motorhome will be honored by Airstream for the duration on that manufacturer's warranty.

Items such as motorhome chassis, engine, tires, batteries and generator are serviced by their respective manufacturers and will be handled by their service centers according to the terms of their written policy. Any warranty forms from these manufacturers should be completed promptly, preferably at time of purchase.

Your motorhome chassis is prechecked by its manufacturer before delivery to Airstream. All service to the chassis must be performed by the manufacturer according to the manufacturer's warranty and service policies. Literature is supplied with each Airstream motorhome which gives important information concerning its warranty coverage; however, the Airstream Limited Warranty covers the chassis heater, defrosters, windshield wiper blade, motor, washer, LP gas bottle and gas regulator.

Paint and appearance items which show imperfections should be brought to the attention of your dealer at the time of delivery and during pre-delivery inspection. Normal deterioration by use and exposure is not covered by the Airstream Limited Warranty.

Damage to enameled or porcelain surfaces resulting from abrasion, collision or impact, and broken window glass is not covered by the Airstream Limited Warranty.

The Airstream Limited Warranty Excludes:

Normal Wear:

Items such as water purifier packs, curtains, upholstery, floor coverings, window, door and vent seals may show wear within the one year Limited Warranty period depending upon the amount of usage, weather and atmospheric conditions.

Accident

Damage caused by accident is usually visible, and we strongly urge our dealers and customers to inspect the motorhome upon delivery for any damage caused by accident while being delivered to the dealer, or while it is on the dealer's lot. Damage of this nature becomes the dealer's or your responsibility upon acceptance of the motorhome. GLASS BREAKAGE, whether obviously struck or mysterious, is always accidental and covered by most insurance policies.

Abuse

Lack of customer care and/or improper maintenance, including failure to comply with the terms of the Owner's Manual, or failure to heed proper vehicle operation shown by the dash instruments are not covered by warranty.

Exposure

Deterioration by sunlight is possible to such items as tires, curtains or upholstery. Steel or metal surfaces are subject to the elements, causing rust and corrosion which is normal and beyond the control and responsibility of Airstream.

Overload

Damage due to loading beyond capacity or to cause improper balance is not covered by the Airstream Limited Warranty. The Airstream motorhome body is engineered to properly handle any normal load. There are limits to the amount of load that can be safely transported depending upon speed and road conditions. If these limits have been exceeded the Airstream Limited Warranty will not cover resulting damage. For additional information on the load capacity of your motorhome consult your Owner's Manual or gross vehicle weight rating plate. The motorhome alignment is checked during the last quality inspection. These tolerances will only change if the motorhome is subjected to abuse, such as dropping off a sharp berm, striking a curb, or hitting a deep hole in the road. Such damage would be considered as resulting from an accident which risks are not covered under the warranty. Abnormal tire wear and/or wheel alignment resulting from such damage is not covered under the terms of the warranty.

SERVICE

The Airstream Silver Key Delivery Program is an exclusive Airstream program. Before leaving the factory each and every vital part of the motorhome is tested for performance. Each test is signed and certified by an inspector. After the motorhome arrives on your dealer's lot all of these vital parts and systems are again tested. When you take delivery of your new motorhome you will receive a complete checkout.

Please contact your dealer if you need service. Major service under your Airstream Limited Warranty is available through our nationwide network of Airstream Dealer Service Centers. An up-to-date list of Dealer Service Centers has been provided with your new motorhome. This list is current as of the date of publication.

Occasionally dealerships change, or new dealers are added who may not appear on this list. For this reason, it is suggested that you contact your local dealer from time to time and bring your list up to date. He can also provide you with additional copies if you need them.

ALL CENTERS OPERATE ON AN APPOINTMENT BASIS FOR THE UTMOST EFFICIENCY.

When you require service from the Airstream Factory Service Center or a Certified Dealer Service Center please contact the service manager for an appointment, and kindly inform him if you are unable to keep the appointment date or wish to change it.

Service may be arranged at the Factory Service Center by contacting the Service Coordinator at:

Airstream Factory
Service Center
419 W. Pike Street
Jackson Center, Ohio 45334
Phone: 513-596-6111

You Should Also be Aware of the Following:

Airstream is not responsible for any consequential or incidental damages incurred as a result of any defect. Consequential damages include, but are not limited to, travel expenses, gasoline, oil, lodging, meals, telephone tolls, loss of work and loss of use of the motorhome.

In the event of a defect, the owner must take all reasonable corrective action to lessen the damages which might result from such defect. Airstream will not be responsible for damages which could have been avoided.

Airstream's responsibility is defined solely by the Airstream Limited Warranty and Airstream is not responsible for or bound by representations or warranties made by any of its dealers.

Your Airstream Limited Warranty is transferable to subsequent owners of the motorhome, but only for the duration of the warranty period. Warranty transfer application forms are available from your dealer or the Airstream factory.

REPORTING SAFETY DEFECTS

If you believe that your vehicle has a defect which could cause a crash or could cause injury or death, you should immediately inform the National Highway Traffic Safety Administration (NHTSA) in addition to notifying Airstream, Inc.

If NHTSA receives similar complaints, it may open an investigation, and if it finds that a safety defect exists in a group of vehicles, it may order a recall and remedy campaign. However, NHTSA cannot become involved in individual problems between you, your dealer, or Airstream, Inc.

To contact NHTSA, you may either call the Auto Safety Hotline toll-free at 1-800-424-9393 (or 366-0123 in Washington, D.C. area) or write to : NHTSA, U.S. Department of Transportation, Washington, D.C. 20590. You can also obtain other information about motor vehicle safety from the Hotline.

MAINTENANCE SCHEDULE

Note: See Spartan and appliance manufacturer's literature for further information.

EVERY 1000 MILES OR 30 DAYS

Escape Window	Check operation of latches and upper hinge
Smoke Alarm	Test and replace battery as required
Tires	Check tire pressure (90 psi)
G FI Circuit Breaker	Test and record

EVERY 5000 MILES OR 90 DAYS

Exterior Door locks	Lubricate with dry graphite
Exterior Hinges	Lubricate with light household oil
LPG Regulator	Check bottom vent for obstructions
Main Door Striker Pocket	Coat with paraffin
Wheel Lug Bolts	Torque to 325 ft. lbs.
Range Exhaust Hood	Clean fan blades and wash filter
Roof Vent Elevator Screws	Lubricate with light household oil
Main Door Step	Lubricate moving parts and check

EVERY 10,000 MILES OR 6 MONTHS

Exterior	Clean and wax
Hitch	Check bolts and welds (90 ft-lb)

EVERY YEAR OR 12,000 MILES

Battery	Clean, neutralize and coat terminals with petroleum jelly
LP Tank	Have purged by LP supplier
Seams	Check seal on exterior seams, windows, lights, and vents. Reseal with Sikaflex or equivalent as needed.

MAINTENANCE RECORDS

Date	Dealer	Service Performed

DRIVING

SAFETY CHECK LIST

Your Airstream motorhome should be given a thorough safety check before a trip. Regular use of the following list will provide safe operation of your motorhome and will help you spot any malfunctioning equipment and correct the problem as soon as possible. The list is to help you and may not be all inclusive.

Failure to heed many of the following items may cause damage to the vehicle or personal injury.

EXTERIOR CHECK LIST (BEFORE ENTERING VEHICLE)

1. Check condition of tires for proper inflation.
2. Turn off LPG valve on LPG tank.
3. Check that sewer connection, all external compartments and filler openings are properly stowed or closed and/or locked.
4. Check that items stored on exterior of vehicle are securely tied down.
5. Would any items stored on exterior of vehicle present a clearance problem?
6. Lower and secure awnings, TV antenna and roof vents.

INTERIOR CHECK LIST (BEFORE DRIVING OFF)

1. It is important that the main door and cab door be completely closed and locked during travel. This includes locking the dead bolt.
2. Turn off living area water pump.
3. Check that refrigerator door is fastened.
4. Check that nothing heavy is stored in overhead or high cabinets which could fall out and cause injury. Heavy items should be stored in low cabinets.
5. Stow folding and pedestal tables.
6. Check that counter tops, range top, credenza tops and shelves are clear of even small items that could become projectiles in an accident.
7. Do not cook while under way. Hot food or liquid could scald due to a sudden stop or accident.
8. Check that any internal stowage is securely held in place.
9. Check that lights and switches are set in positions safe for travel.

10. Adjust the driver's seat so that you can easily reach and operate all controls. Make sure seat is locked in position. Do not adjust driver's seat swivel or fore and aft mechanism while vehicle is moving. The seat could move unexpectedly causing loss of control.
11. Check that front passenger's seat is locked in position - both fore and aft adjustment and swivel mechanism.
12. Check rear view mirror adjustment, inside and outside. Adjust curtains if necessary for maximum visibility.
13. Fasten lap belts.
14. Check that step light goes out and that electric step has retracted.

SAFETY SEAT BELTS







In the forward driver's area of the motorhome, safety seat belts are provided for the use of the driver and the right front passenger. Safety belts are available for other seats. It is strongly recommended that all occupants remain seated with their safety belts firmly attached while the motorhome is in motion. The driver should adjust his seat so that he is able to reach all controls easily with the belt on, especially able to use all the travel on the foot brake. The belt should be placed as low as possible around the hips to prevent sliding out from under them in case of accident. This places the load of the body on the strong hip bone structure instead of around the soft abdominal area. Two people should never try to use the same seat belt.

WARNING: Children must be secured in a Federally Approved Child Restraint Device. Failure to use proper restraints can result in severe or fatal injuries in case of accidents.

Child restraint devices are designed to be secured with lap or lap/shoulder belts. All instructions supplied by the restraint manufacturer must be followed. Statistics have shown children are safer when properly restrained in a rear seating position than in a front seating position.

Often the children traveling in motorhomes are grandchildren. There are times when our love for grandchildren makes us hesitate to properly supervise their actions. Don't hesitate when it comes to their safety. Make sure they are properly restrained.

CHILDREN HAVE LOVED ONES TOO...IF YOU WON'T BUCKLE UP FOR YOURSELF, BUCKLE UP FOR THEM.

-  DR LOCK
-  AUX BATT
-  GEN
-  AISLE LTS
-  DRIV LTS
-  CTSY LTS
-  SPARE

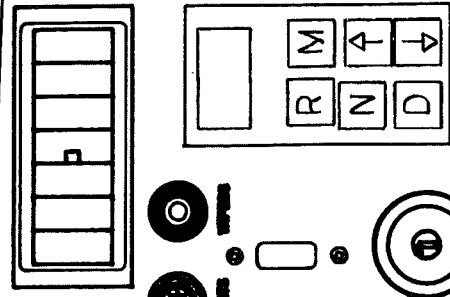
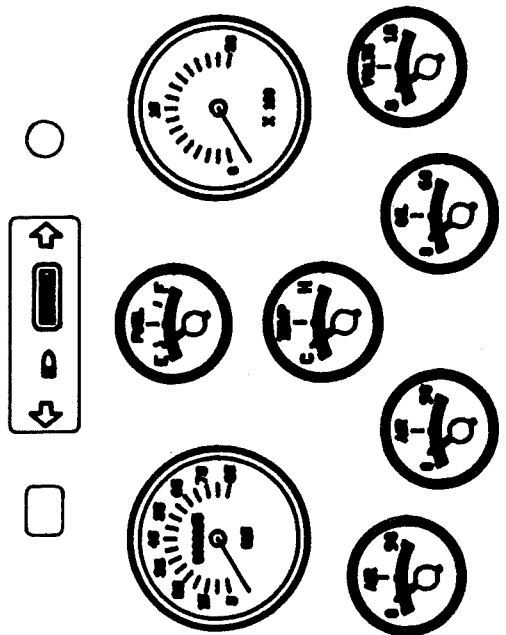
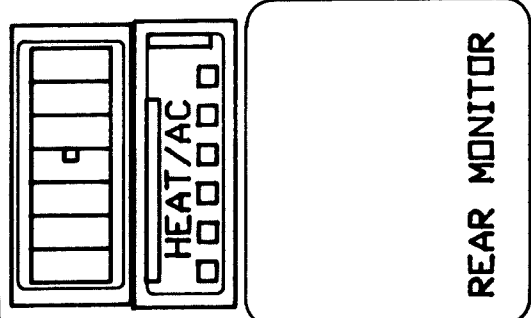
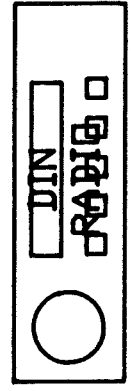

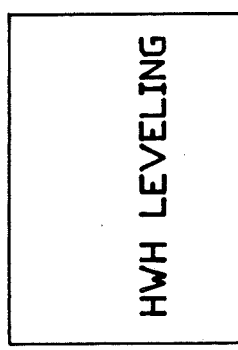
AIRSTREAM DASH CONTROLS

Most automotive gauges and controls are standard Chevrolet instruments. Their function and use is described in your Spartan Drivers Manual. The exception on automotive controls is the heater/air conditioner and "Smart Stick." Operating instructions on these components can be found in the chassis section of this manual.

Right side switches:

- **Door Lock** - The main door can be locked or unlocked from the drivers seat. Remember to hide an extra door key on the exterior in case of unexpected battery failure.
- **Auxiliary Battery** - The auxiliary start switch is intended to be used if the engine battery becomes to discharged to turn the engine over. To operate, hold the switch in the start position, then use the ignition switch in a normal fashion. Operating the auxiliary start switch closes the points on a large solenoid, tying all three vehicle batteries together for increased starting power.
- **Generator Switch** - The remote generator switch on the dash allows the driver to start or stop the generator without leaving the driver's seat. It should be noted a built-in time delay allows the generator to reach full operating speed before 120 volt current is provided to the coach.
- **Courtesy Light** - The courtesy lights are low intensity lights along the dash.
- **Aisle Lights** - The low aisle lights will allow passengers to converse without using overhead lights that could be bothersome to a driver at night.
- **Docking Light** - This switch powers exterior lights on the curbside exterior of the coach and the curbside front cornering lamp (the roadside cornering lamp is not in this circuit).

FLOOD LIGHT

(Optional, not shown) Two switches control the operation of the search lights. The left hand switch controls the directional movement of the lights. Move it up or down, right or left, and the light will move in the same direction. The right hand switch illuminates the light in either spot light or flood light mode.

CAB SEATS

The cab seats will adjust three ways for maximum comfort. Three levers control the operation. The levers in the end of the arm rest control the recline and swiveling of the seat. A lever under the front left side of the seat allows forward and backward adjustment.

WARNING: Never adjust drivers seat while vehicle is in motion.

POWER SEAT CONTROLS

Power seat controls have three switches. The center switch moves the seat up and down, forward and back. The other two switches control the tilt of the seat. If the seat is run to the end of its movement in any direction a stall condition will exist and a 12 volt automatic circuit breaker will "kick-out" to avoid damage to the motors. If this occurs wait approximately 30 seconds and operate the switch in the opposite direction.

CAUTION: Revolving the power seat completely around will pull the wiring apart. The seats should only be swiveled toward the center of the vehicle. If the wires are loosened they can be reconnected by following the color code: Red to red, green to green, etc. On some models the wires will be on a plug that can be reattached.

TRAILER TOWING AND DRIVING TIPS

Since this vehicle is designed and intended to be used primarily as a load carrying vehicle, towing a trailer will affect handling, durability and economy. Maximum safety and satisfaction depends upon proper use of correct equipment and avoiding overloads and other abusive operation.

CAUTION:

The maximum loaded trailer weight which you can pull with your vehicle is 2,000 lbs. Vehicles should be properly equipped for towing trailers. Information on trailer hauling capabilities and special equipment required may be obtained from your Airstream dealer.

To assist in attaining good handling of the vehicle/trailer combination it is important that the trailer tongue load be maintained at approximately 10% of the loaded trailer weight, but not to exceed 200 lbs. Tongue loads can be adjusted by proper distribution of the load in the trailer, and can be checked by weighing separately the loaded trailer and then the tongue.

When towing trailers, tires should be inflated to the highest pressures shown on the information plate attached to the drivers door jamb of your motorhome. The allowable passenger and cargo load (GVW) of this vehicle is reduced by an amount equal to the trailer tongue load on the trailer hitch.

Trailer brakes are required on axles of trailers over 1,000 lbs. loaded weight.

CAUTION:

Spartan does not recommend lifting the front of the motorhome for towing.

In the unlikely event a disabling break down should occur, transporting the vehicle on a flat bed is the preferred method. Feel free to have the tow company call Spartan at 800-543-4334 for directions.

NOTES

CHASSIS

The Airstream motorhome is built on a Spartan chassis. Operation of the Spartan engine and other related components is discussed in the Spartan Owners and Drivers Manual supplied with each coach.

If repairs are needed it can be difficult to determine which parts of the chassis are warranted by Spartan, and which are Airstream's responsibility. The following list shows the major components of the chassis and the company responsible for their servicing.

Spartan EC2000

Engine	Front Suspension, Air Bags
Transmission	Drive Axle and Hubs
Brakes	Shocks
Steering Assembly	Automotive Fuse Panel
Front Spindle, Bearings	Parking Brake
Steel Wheels	Fuel Tank
Alternator	Cruise Control
Turn Signals	Wheels

Airstream

Auxiliary Heater	Air Horn
Dash Air Conditioner/Heater	Isolator
Windshield Wipers	

The above list covers almost all of the chassis components. If you need further clarification or information your dealer should be contacted with the details.

DASH AIR CONDITIONER/HEATER

Acme Radiator Air Conditioning, Inc.
17103 St. Rd. 4E
Goshen, Indiana 46526
800-552-2263

OPERATION

The operation of your dash air conditioner/heater is practically identical to those found in most automobiles. Three controls are involved. The fan switch varies the amount of air flow through the system. The "mode" controls between heat, air conditioning, defrost, floor and panel. So mode not only determines the part of the system you want to use but also the area where either the hot or cold air will be vented into the coach. The temperature control lever controls the amount of hot water being allowed to flow through the heater core.

SERVICE

Acme has requested you to call them on the 800 number listed above should you experience any service problems. They are usually able to help get any repairs needed at an air conditioner repair facility close to your location.

The following pages include wiring diagrams and vacuum line diagrams.

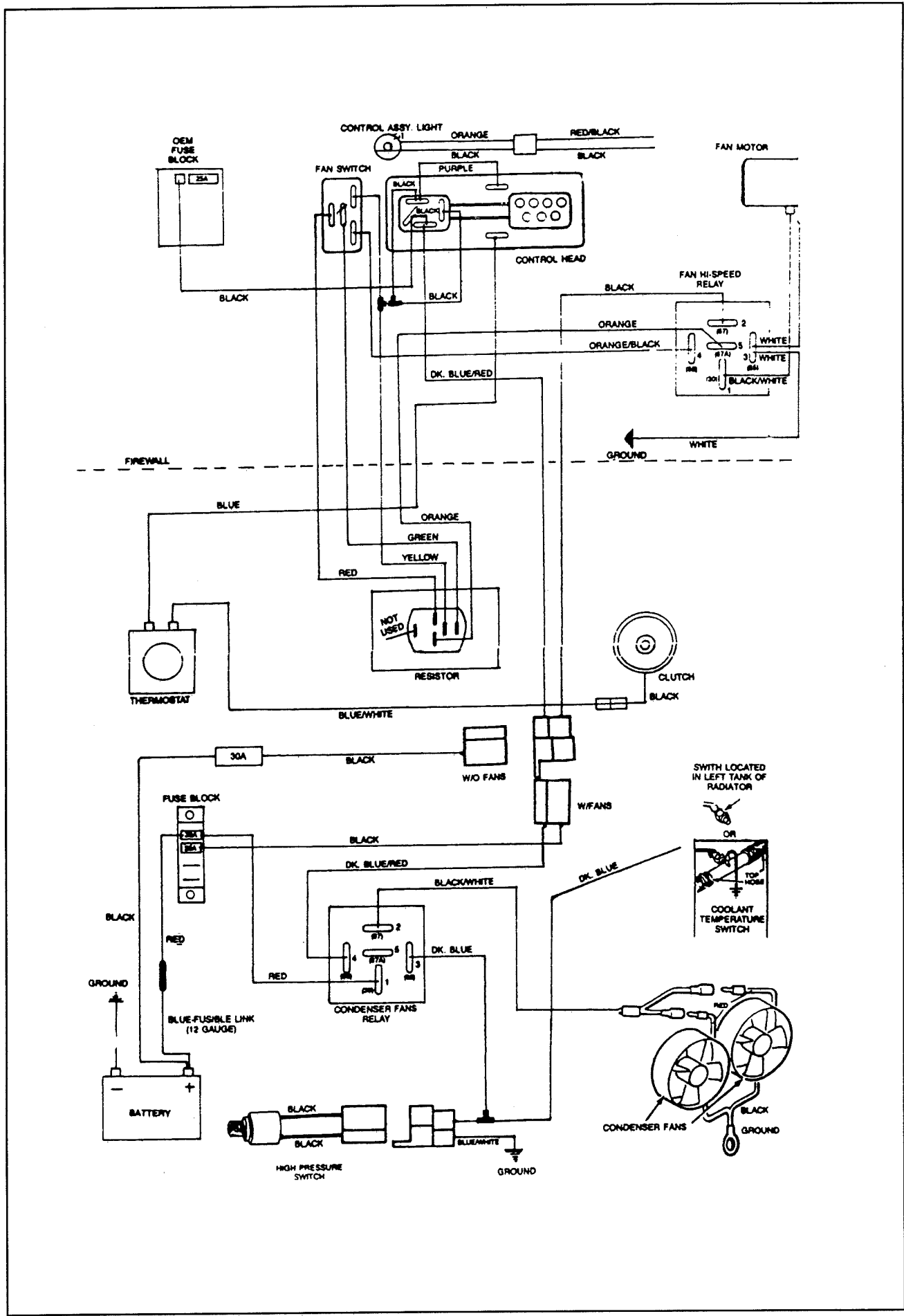

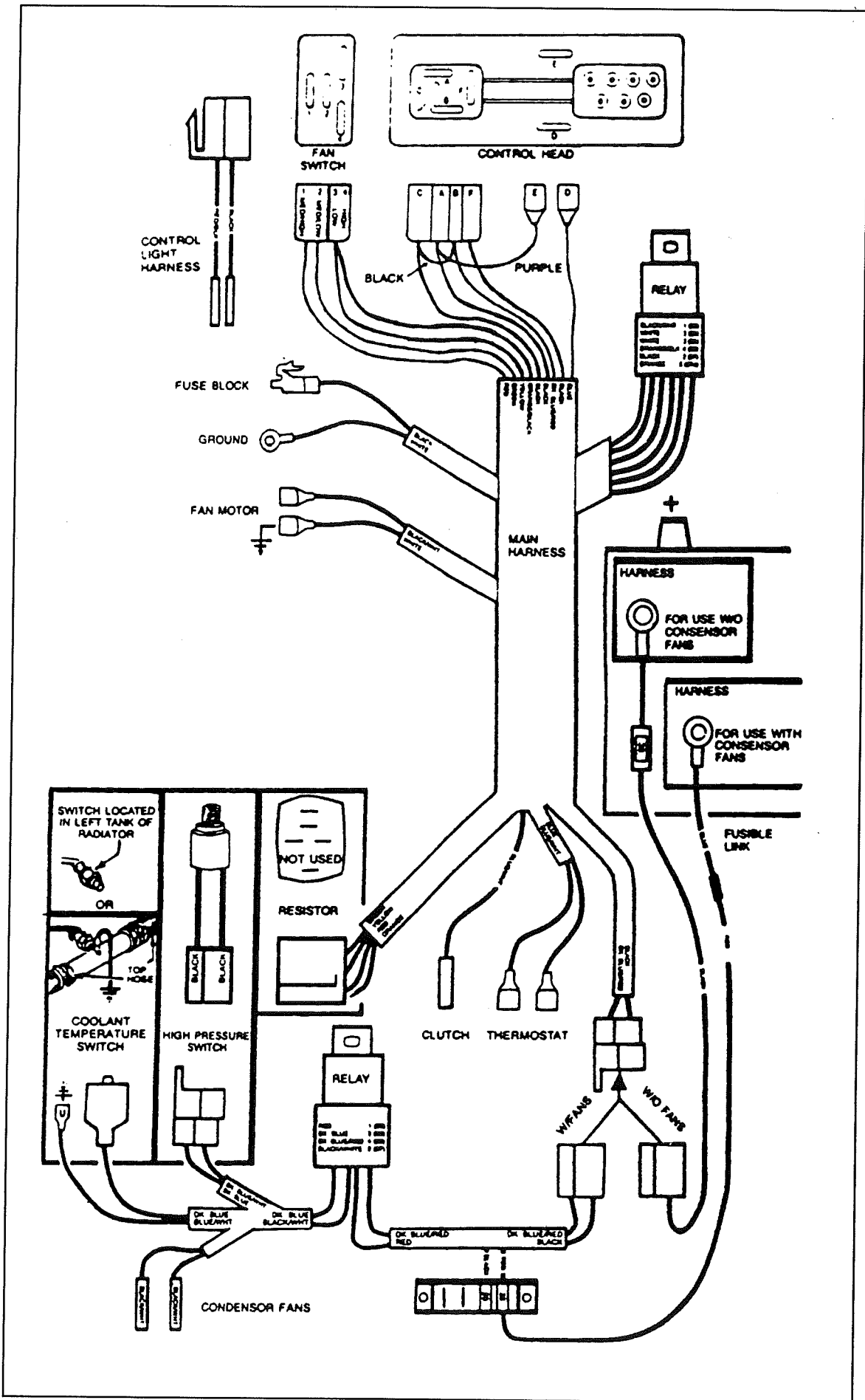

VACUUM SCHEMATIC

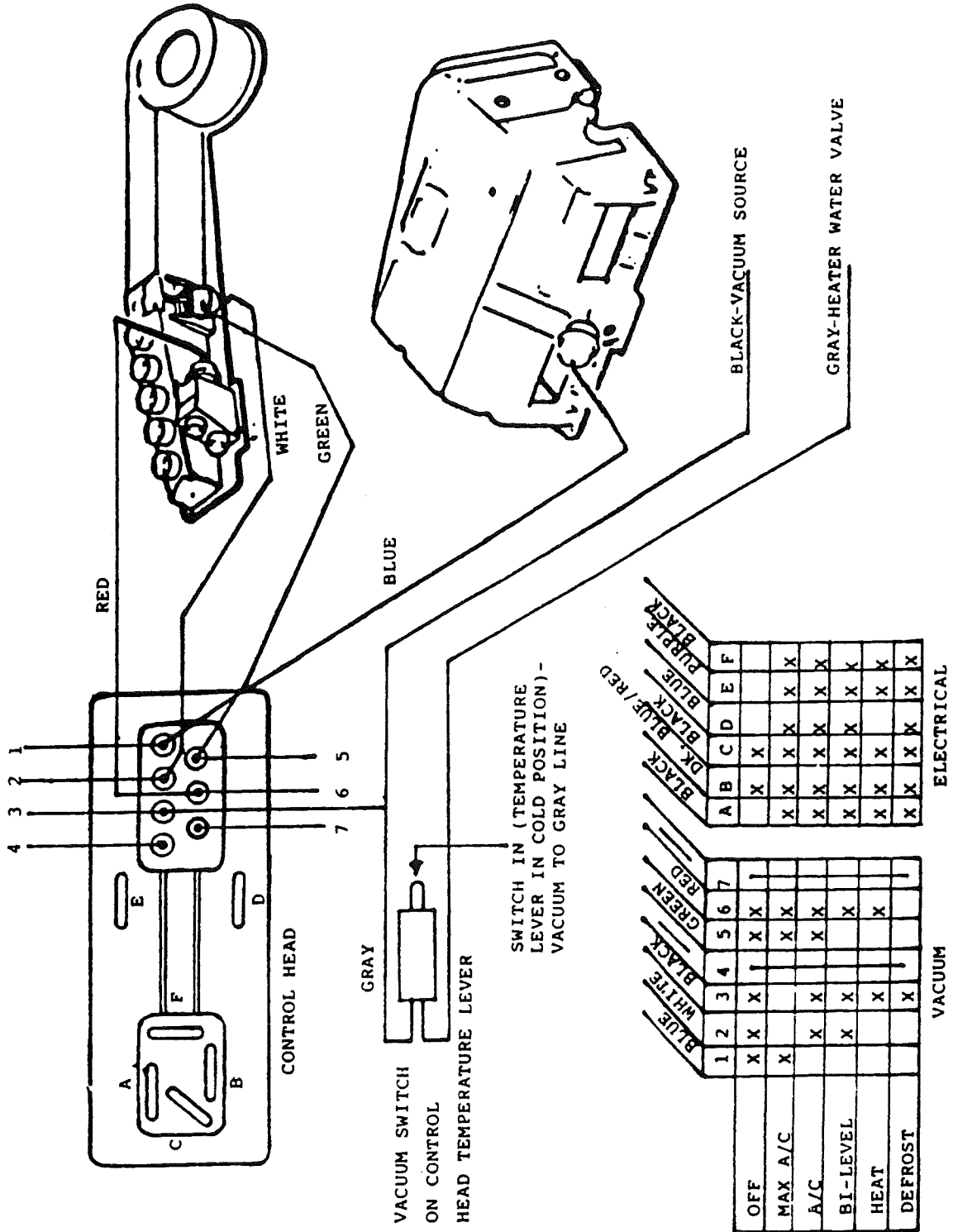

NOTES

WINDSHIELD WIPER ASSEMBLY

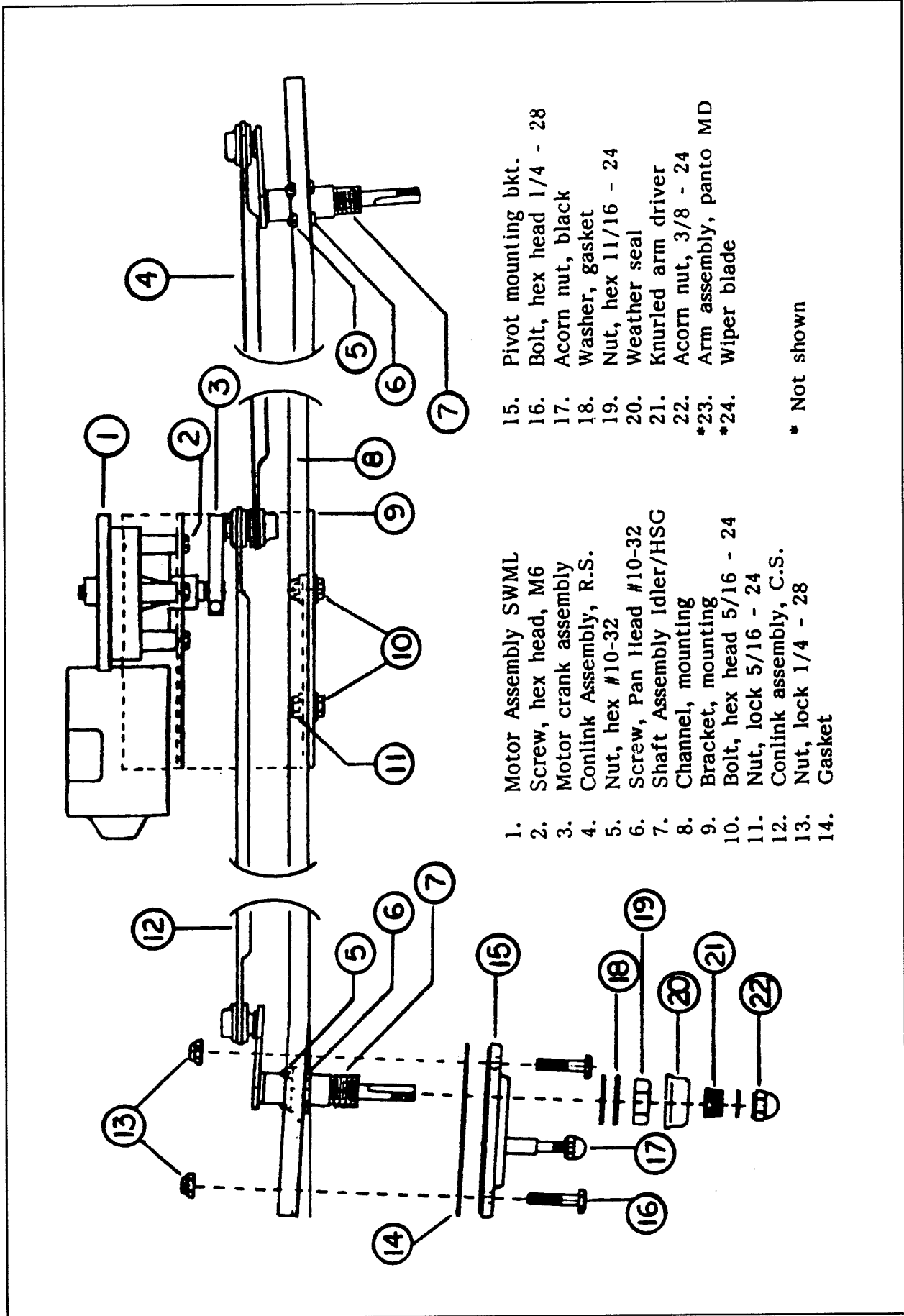

1. Motor Assembly SWML
2. Screw, hex head, M6
3. Motor crank assembly
4. Conlink Assembly, R.S.
5. Nut, hex #10-32
6. Screw, Pan Head #10-32
7. Shaft Assembly Idler/HSG
8. Channel, mounting
9. Bracket, mounting
10. Bolt, hex head 5/16 - 24
11. Nut, lock 5/16 - 24
12. Conlink assembly, C.S.
13. Nut, lock 1/4 - 28
14. Gasket

15. Pivot mounting bkt.
16. Bolt, hex head 1/4 - 28
17. Acorn nut, black
18. Washer, gasket
19. Nut, hex 11/16 - 24
20. Weather seal
21. Knurled arm driver
22. Acorn nut, 3/8 - 24
- *23. Arm assembly, panto MD
- *24. Wiper blade

* Not shown

ELECTRIC STEP (KWIKEE STEP)

Manufacturer: Kwikkee Products Company
Division of Ashton Corporation
P.O. Box 638
Drain, Oregon 97435
Phone: 503-836-2126

The step is easy and convenient to operate. Just inside the main door is a wall switch for the step. When traveling leave the switch in the "ON" position. The step will lower when the door is opened and retract when the door is closed.

When parked, open the door so the step is lowered. Then shut the switch off. The step will remain in the lowered position and the "step" light on the dash will be extinguished.

If you forget and leave the switch off as you leave - No Problem! When the ignition is "ON" the wall switch is by-passed and the step will retract when the door is closed.

WARNING: If the wall switch is turned off, and the step is in the retracted position when the ignition is turned off, the step will not lower when the door is opened. Keep your passengers informed.

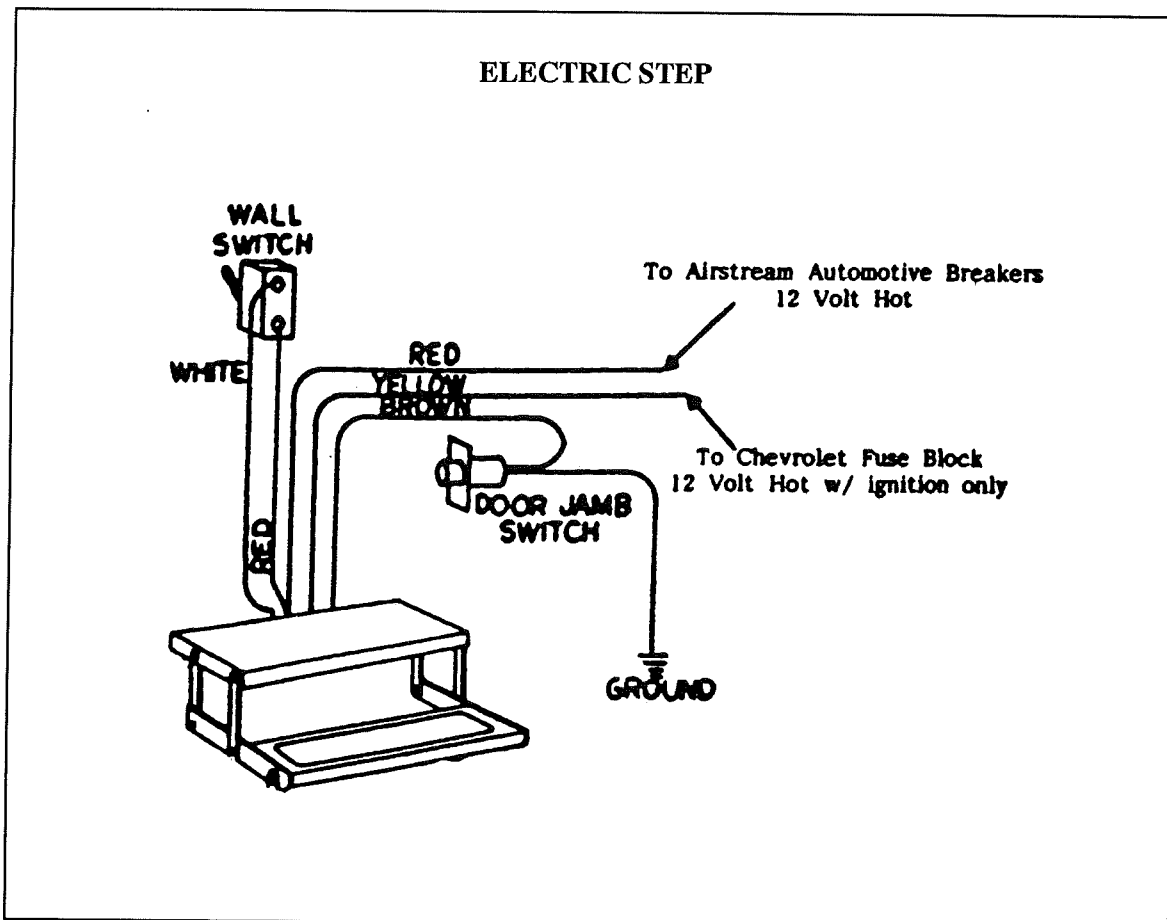

OPERATING INSTRUCTIONS

For control units #9514 and #9591

1. After the installation is complete and with the entrance door open, turn the power switch on.
2. Close the door. The step should retract and lock in the up position.
3. Open the door. The step should extend and lock in the down position with the understep light on. **NOTE** - *The under step light is not available on all step models.*
4. Turn the power switch off. The step should remain in the extended position with the understep light off when the door is closed. The procedure can also hold the step in the retracted position.
5. With the power switch off, the step extended, and the entrance door closed, turn on the vehicle ignition. The ignition safety system will go into effect and the step will automatically retract.

NOTE - *If the yellow wire was not connected in Step #11 of the HOOKUP PROCEDURE the ignition safety system is inoperative and the step will remain in the extended position. If the vehicle is driven with the step in the extended position there is the possibility of causing major damage to both the step and the vehicle. The power switch must be turned on for the step to retract.*

WARNING: *When the ignition safety system goes into effect and the step automatically retracts, DO NOT OPEN THE DOOR until the step completely retracts. If the door is opened before the step completely retracts and locks in the up position, the step will stop moving. The step may only be partially extended. Stepping on a partially extended step may cause damage to the step frame and/or motor assembly. When the door is closed the step will finish retracting.*

WARNING: *If the entrance door is opened before the vehicle ignition is turned off, the step will extend as soon as the ignition is turned off, even if the power switch is off. If the step is not allowed to extend fully and lock out before the door is closed, the step will stop moving. The step may only be partially extended. Stepping on a partially extended step may cause damage to the step frame and/or motor assembly. If the door remains closed, the step will retract if either the ignition or power switch are turned on. If the door is reopened the power switch must be turned on for the step to finish extending.*

WARNING: *If your step does not have the "last out" feature, it will not extend once the ignition has been turned off and the door is opened. The power switch must be turned on in order to operate the step. To determine if your unit has the "last out" feature follow these procedures: With the ignition switch on, the door closed, the power switch off, and the step retracted, turn off the ignition. Open the door. If the step extends, your unit is equipped with the "last out" feature.*

Be Safe - Look Before You Leap!

General Service Notes

If the power wire to the step is disconnected from its source and reconnected, a spark is common. This is caused by the momentary charging of the control unit and does not necessarily indicate the system is staying on, causing a drain on the battery.

If battery drain is suspected, observe the understep light (if so equipped) while the step is extending. The power switch must be on for the understep light to operate. When the step locks into the down position, the understep light should become noticeably brighter. If it does not, the control may not be shutting off. Turn the power switch off and unplug the four way plug between the control unit and the vehicle to prevent overheating the motor.

To further determine that the control is not shutting off, remove the two (2) screws from the connector on the motor leads between the motor and control unit. Remove the seal assembly. (See Figure 2 on page #8) Place a voltmeter between the red and yellow motor leads than reconnect the four way plug. Turn the power switch on. If any voltage is read, the control is not shutting off and may be defective. When doing this test, switch the voltmeter leads back and forth between the red and yellow motor leads to be sure no voltage shows. If any voltage shows, disconnect the four way plug to keep the motor from overheating. If zero voltage is present, the control has shut off and is normal.

If the step does not work or operates erratically, such as extending part way and shutting off, the first item that should be checked is the vehicle battery. The voltage across the battery terminals should be at least 12.7 volts DC to insure a well charged battery. A battery that reads below 12.7 volts DC may drop as low as 8 volts DC when a load is drawn, such as the engaging of the step motor. The control unit will shut off if the loaded voltage falls below 9 volts DC. The control unit will remember which function it was performing. It will wait between two and five seconds (time depends upon temperature) and will try again to complete the original function. If the supply voltage is still below 9 volts, the control will go into another delay state. If the supply voltage remains above 9 volts DC, the original function will be completed. Should the supply voltage again fall below 9 volts the system will go into another delay state. It may take a couple of minutes to complete the original function. Low supply voltage may cause erratic operation of the step. Intermittent ground may also cause erratic operation of the step.

The step may also operate erratically if the step is being operated directly from a converter and the output from the converter is not adequate or properly filtered for clean DC voltage. The converter must be capable of producing a minimum of 30 amps for proper step operation.

If the control unit is hooked up electrically backwards, the step will not operate. If ground to the control unit is lost, either between the step control unit and the vehicle chassis (the 31" long 10 ga. green ground wire), or between the vehicle battery and ground (negative battery cable) the step will not function.

Make sure the battery terminals and all wire connections are clean and tight.

Be sure all wires are of proper gauges or heavier as specified in the wiring diagram.

WARNING: IMPORTANT: No other devices (hearers, fans, burglar alarms, lights, etc.) can be incorporated in the same circuit as the control unit or step. This may cause the step or control unit to malfunction and may void the warranty.

Check the step for physical damage. If the step has been struck by some kind of road hazard, the step mechanism may be bent, causing the step to bind. Check the tread, sliding rails, and extending arms for physical damage. Also check the pivot points for rusting. (See the LUBRICATION AND MAINTENANCE SCHEDULE).

If the power switch is on and the step will not extend when the door is opened and/or retract when the door is closed, but there is a clicking noise coming from the control unit (the engaging and disengaging of the relays in the control unit) the first item that should be checked is the

motor. See the MOTOR TEST PROCEDURE. The relays will engage and disengage (the clicking noise) when the door switch is cycled if the motor is malfunctioning.

These general service notes and the following test procedures cover the most common problems associated with Kwikkee electric steps. Due to the number of variable conditions available, you may experience symptoms other than those covered. Please feel free to contact the customer service department at 1-800-736-9961 for further information or assistance.

TEST PROCEDURE - VEHICLE WIRING

Read the General Service Notes before starting any test procedure.

1. Unplug the four way plug between the control unit and the vehicle wiring. (See Figure 2)

2. **TO CHECK THE MAIN POWER SOURCE:** Connect a voltmeter between the RED wire from the vehicle half of the four way plug and the ring terminal on the end of the 10 ga. green ground wire from the control unit to the vehicle chassis (See Figure 3). NOTE - Steps manufactured before August 26, 1991 used a braided ground cable to ground the step to the vehicle chassis. The control unit on steps manufactured after that date are grounded directly to the vehicle chassis by the 10 ga. green ground wire as shown in Figure 2. If the step is equipped with a braided ground cable, substitute the braided ground cable in place of the green ground wire in these test procedures. The reading should be about 12 volts DC. If the voltage is low there may be a loose or corroded connection, or low battery charge. If the voltage reading is zero, check the 25 or 30 amp fuse/circuit breaker and all connections. Be sure there is a good ground connection between the step frame and the vehicle chassis. See Step #2 of the HOOKUP PROCEDURE. A good ground connection is a must. If the reading is approximately 12 volts DC proceed with the next test.

3. **TO CHECK THE POWER SWITCH:** Connect the voltmeter between the WHITE wire from the vehicle half of the four way plug and the ring terminal on the green ground wire (See Figure 4) The reading should be about 12 volts DC with the power switch on and zero when the switch is off. If the voltmeter reads zero with the power switch on, the first item to check is the inline fuse or circuit breaker in the wire between the power switch and the power lead (red wire). If the

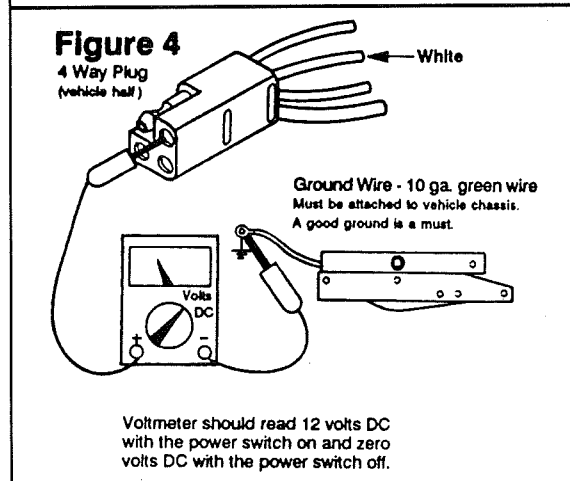
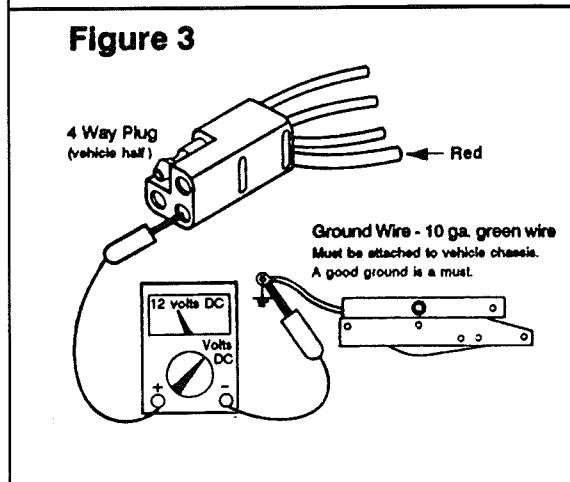
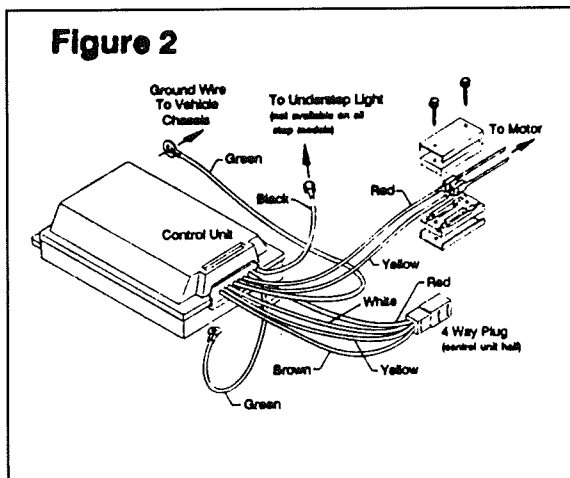

fuse/circuit breaker is all right, connect the voltmeter between the terminal on the power switch with the wire leading to the power wire (red wire) and ground (See Figure 5). If the reading is still zero check the wire leading to the power lead for a loose connection or cut wire. If the reading is about 12 volts DC, turn on the power switch and check the other power switch terminal in the same manner, by connecting the voltmeter between the terminal and ground. If the reading is zero, replace the power switch. If the reading was about 12 volts DC, there may be a loose connection or cut wire between the power switch and the vehicle half of the four way plug.

4. **TO CHECK THE DOOR SWITCH:** Connect the voltmeter between the RED wire from the vehicle half of the four way plug and the BROWN wire in the same plug (See Figure 6). The reading should be about 12 volts DC when the door is open and zero when the door is closed. If the reading is zero with the door open, check the ground connection from the door switch. This connection should be clean and tight. See Step #8 of the HOOKUP PROCEDURE. An improper ground can cause intermittent of erratic operation of the step. If the step will not retract after being extended or extends with the door closed, the BROWN wire to the door switch may be touching a grounded surface inside the wall behind the door jamb, or the door switch terminals may be touching a grounded surface or each other. If the step extends and retracts by itself while traveling, check the conditions previously described. With plunger door switches, be sure that the door switch plunger is depressed at least two thirds of its travel when the door is closed. If the switch is not depressed at least two thirds of its travel, it is possible for the switch to make intermittent contact as the vehicle frame shifts slightly while traveling along the roadway. With magnetic door switches, be sure the magnet is in place and proper clearance is maintained between the switch and magnet. If all the previous conditions check okay, the door switch may be faulty.

Figure 5

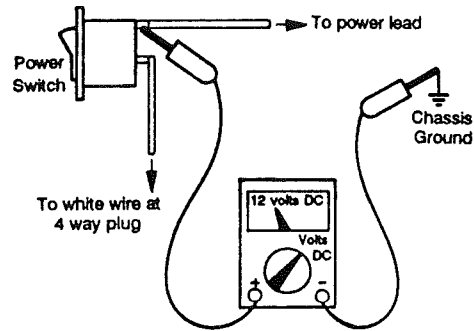

Note- One terminal of the power switch should always be "hot". The other terminal should only be hot when the switch is on.

Figure 6

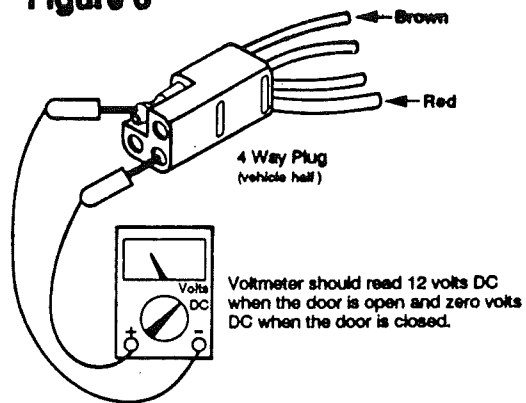

Voltmeter should read 12 volts DC when the door is open and zero volts DC when the door is closed.

Figure 7

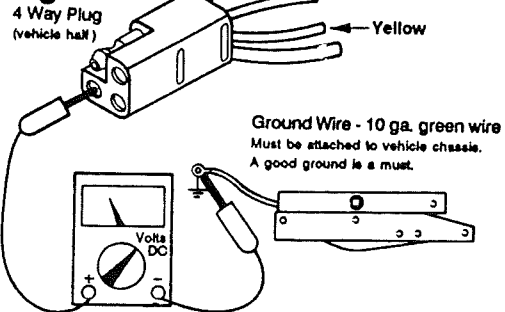

Voltmeter should read 12 volts DC when the ignition is on and zero volts DC when the ignition is off.

Figure 8

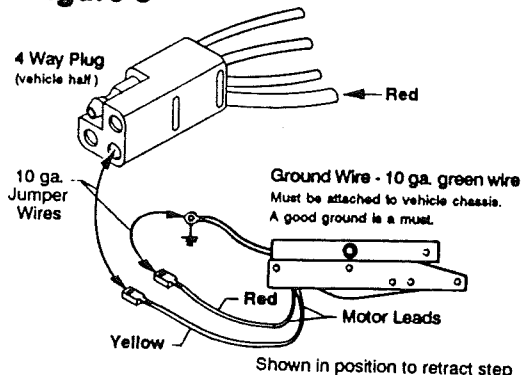

Shown in position to retract step

5. **TO CHECK THE IGNITION SAFETY SYSTEM:** Connect the voltmeter between the YELLOW wire from the vehicle half of the four way plug and the ring terminal on the green ground wire (See Figure 7). The reading should be about 12 volts DC when the ignition is on and zero when the ignition is off. If the reading is zero when the ignition is on, check the connection of the yellow wire at the vehicle's fuse panel. If connected at a fuse, check for a blown fuse. **NOTE - *On some installations there may be an inline fuse or circuit breaker in the YELLOW wire that should be checked. Kwikkee Products Company, Inc. recommends that this fuse/circuit breaker be installed at this time if the Yellow wire is not already fused.*** If the reading was about 12 volts DC when the ignition was off, the YELLOW wire is connected to a constant live source. ON control units #9513 and #9590, if the YELLOW wire is connected to a constant live source, the step will always activate with the door movement, even if the power switch and ignition are off.

NOTE - *On some travel trailer and fifth wheel applications, the ignition safety system may not be connected and the voltmeter reading will be zero between the YELLOW wire and the ground wire.*

TEST PROCEDURE - MOTOR TEST

6. When checking the motor, remove the two (2) screws from the connector on the motor leads between the motor and control unit. Separate the seal assembly exposing the connectors on the red and yellow motor wires. **CAUTION: *Make note of how the wires and connectors are assembled for reassembly later. The wire connectors may be assembled wrong even though the colors match.*** Disconnect the motor leads

WARNING: *Under no conditions should power be applied to the motor leads while the motor is still connected to the control unit or damage to the control unit will result - voiding the warranty.* Connect a 10 gauge jumper wire to the RED wire in the vehicle half of the four way plug. This wire must have power. See Step #2 of the VEHICLE WIRING TEST PROCEDURE: Connect another 10 gauge wire to the ring terminal on the end of the 31" long 10 ga. green ground wire (See Figure 8).

TO RETRACT STEP: Connect the ground jumper wire (jumper from the green ground wire) to the RED motor lead. Touch the power jumper wire (jumper from four way plug) to the YELLOW motor lead.

TO EXTEND STEP: Connect the ground jumper wire (jumper from the green ground wire) to the YELLOW motor lead. Touch the power jumper wire (jumper from four way plug) to the RED motor lead.

CAUTION: *Do not leave the jumper wire connected to the motor terminal for more time than it takes to extend or retract the step or damage to the motor may result.*

If the motor fails to move, the motor may be defective. If the step has been struck by some kind of road hazard, the step mechanism may be bent and causing the step to bind. The control unit would then shut off power to the step [as described in the BASIC SUMMARY OF OPERATION. Check for physical damage to the tread, sliding rails, extending arms, etc. Also check all pivot pints for rusting. (See the LUBRICATION AND MAINTENANCE SCHEDULE).

If the step doesn't move when power is applied to the motor terminals, but a dim spark is noticeable, there may be damage to the windings inside the motor, requiring replacement of the motor. A dim spark may also indicate a shorted or burned out motor requiring replacement.

If the motor is defective, refer to page #10 and #11 for instructions for removing the motor from the motor assembly.

TEST PROCEDURE - CONTROL UNIT TEST

7. The motor must be operational to test the control unit using this procedure. See MOTOR TEST PROCEDURE.

a. Ground the negative (-) post of a well charged 12 volt DC battery to the ring terminal on the end of the 31" long 10 ga. green ground wire.

NOTE : A well charged battery will read at least 12.7 volts DC when a voltmeter is connected between the battery posts.

- b. The motor leads must be connected to the control unit.
- c. The four way plug between the control unit and the vehicle should be disconnected. Install pigtail (four way plug - vehicle half - Part #9336 - same plug as supplied with the step for connection to the vehicle) into the control unit half of the four way plug.
- d. Touch the RED and WHITE wires of the pigtail to the positive (+) post of the battery. At the same time, touching the BROWN wire to ground (10 ga. green wire) will cause the step to extend. **CAUTION: Keep hands clear of the step mechanism.**
- e. When the BROWN wire is removed from the green ground wire the step should retract.
- f. Extend the step again by applying power to the RED and WHITE wires and grounding the BROWN wire to the green ground wire. Remove the RED and WHITE wires from the battery before removing the BROWN wire from ground. THIS will cause the step to remain in the extended position.
- g. To test the ignition safety system circuit, apply power to both the RED and YELLOW wires of the four wire pigtail and the step should retract.
- h. On control units #9513 and #9590: To test the "last out feature", remove the YELLOW wire from the battery without removing the RED wire. Ground the BROWN wire to the green ground wire and the step should extend. If the RED wire is removed from the battery before grounding the BROWN wire, SStep #7f and #7g must be repeated before testing the last out feature. This test will only work if performed immediately after the ignition safety system test.
- i. If the control unit tests okay, then recheck all wire and ground connections. If the source of the trouble cannot be found, feel free to contact the customer service department for further information or assistance.
- j. If the above tests do not check out, the control unit may be defective and should be returned to the factory for evaluation.

In most cases the control unit does not fail and problems can be traced to vehicle wiring or voltage problems.

Instructions for removing the motor assembly (part #9501, #9502, #9503, or #9504) from the step frame and disassembly:

Read all instructions before starting any procedure.

Refer to the motor assembly exploded view drawing on the opposite page for the item numbers referred to in these instructions.

1. Unplug the control unit from the vehicle (four way plug). Do not cut any wiring.
2. Remove the two (2) screws (Item #12) from the connector (Item #18 and #19) on the motor leads between the motor and the control unit. Remove the seal assembly (Item #20). **CAUTION: Make note of how the wires and connectors are assembled for reassembly later. The wire connectors may be assembled wrong even though the colors match.** (See Figure 2 on page #8).
3. It is easiest to remove the motor assembly from the step frame if the step tread(s) are in a partially extended position. Try to extend the step by following the procedure outlined in Step #6 under the TEST PROCEDURE - MOTOR TEST. If the step is locked in the up position and will not move, read Steps #4 and #5 below before proceeding.
4. Remove the hair pin (Item #6) from the clevis pin (Item #7).
5. Remove the clevis pin (Item #7) from the cast block in the end of the linkage assembly (Item #7, #9, or #10). Note which direction the clevis pin goes into the cast block. If the step is in its locked position, the clevis pin may have to be pried or driven out of the block. If the step is in the locked position, loosening the motor assembly mounting bolts may allow the clevis pin to be removed easier. The step tread(s) should swing freely when the clevis pin is removed. If the tread does not move freely, check for a bent step frame and for rusting at the pivot points.
6. **MOTOR REMOVAL:** The motor (Item #5 or #5A) may be removed without removing the gear box or linkage assembly simply by removing the three (3) screws (Item #4) along with the bearing bracket (Item #2).
7. **GEAR BOX REMOVAL:** Unbolt the gear box mounting plate (Item #16) from the step frame.
8. Remove the bearing (Item #3) and the linkage assembly (Item #8, #9, or #10) from the gear case (Item #11) along with the adapter gear (Item #1) and shaft (Item #17).
9. Turn the gear box assembly over and remove the four (4) 1 1/4" long #10 self tapping screws (Item #13) from the gear case. Lift off the mounting plate (Item #16)
10. Remove the bearing (Item #3). Lift off the gear case cover (Item #15) and lift out the gear (Item #14). Note which side of the gear goes up.

Reassembly and Installation of the motor assembly(part #9501, #9502, #9503 and #9504) on the step frame

Read all instructions before starting any procedure.

Refer to the motor assembly exploded view drawing on the opposite page for the item numbers referred to in these instructions.

1. **NOTE** - In the following assembly be sure all bearing pocket and surfaces, gear teeth and the gear hub socket that is in the gear case are well lubricated with a good grade of lithium based grease.
2. Install the gear (Item #14) in the gear case (Item #11). Be sure the gear is reinstalled the same way it was removed (With the penny sized depressions down).
3. Place the gear case cover (Item #15) on the gear case. Set the bearing (Item #3) in the center hole of the gear case cover (the flange of the bearing should be up) and align the square hole in the bearing with the square hole of the gear.
4. Place the mounting plate (Item #16) on the gear case cover (the square holes in the mounting plate should be away from the motor) and install and tighten the four (4) 1 1/4" long #10 self tapping screws (Item #13)
5. Turn the motor assembly over and set it on the flat mounting plate. Install the linkage assembly (Item #8, #9, or #10) into the gear case. Be sure the linkage assembly seats all the way into the gear and bearing or the bearing bracket (Item #2) will not set properly. The swivel ball and cast block should face the front of the motor assembly.
6. Place the bearing (Item #3) on the linkage assembly shaft. Place the flange of the bearing down.
7. Lubricate and set the adapter gear (Item #1) and adapter gear shaft (Item #17) in place and mesh with the main gear (Item #14).
8. Replace the motor (Item #5 or #5A) by carefully aligning the motor and adapter gear (Item #1) so they slide together. Align the screw holes and push the motor into the screw hole alignment pickets in the gear case.
9. Place the bearing bracket (Item #2) on the motor assembly and install and tighten the motor screws (Item #4). These screws must be very secure.
10. Reinstall the motor assembly on the step frame and tighten all mounting bolts.

NOTE - Be sure the motor assembly is positioned the same way the old one was prior to removal.

11. Install the clevis pin (Item #7) through the drive arms attached to the step frame and the cast block in the linkage assembly (Item #8, #9, or #10). Be sure to reinstall the clevis pin in the same direction it was removed. Install the hair pin (Item #6) in the clevis pin.
12. Reassemble the motor to control unit leads. See Step #2 under disassembly.
13. Connect the control unit to the vehicle (four way square plug).
14. Test step functions.

Motor Assembly

Note - Item #9 (part #9565) - identified by a 7/32" dia. hole under the edge of the straight ball drive link.

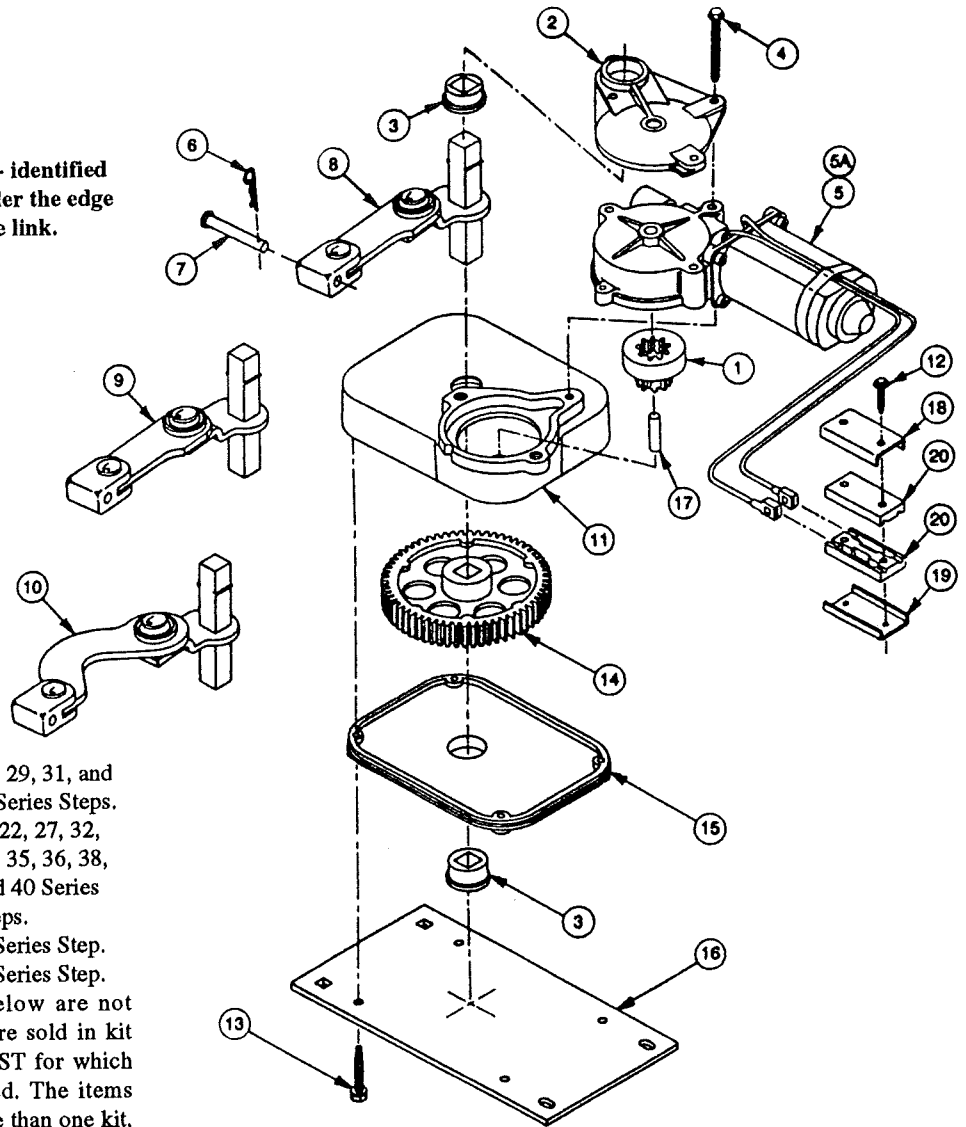

Motor Assembly #9501 - 28, 29, 31, and 39 Series Steps.

Motor Assembly #9502 - 21, 22, 27, 32, 34, 35, 36, 38, and 40 Series Steps.

Motor Assembly #9503 - 23 Series Step.

Motor Assembly #9504 - 26 Series Step.

NOTE - The items listed below are not available individually. They are sold in kit form only. See the PARTS LIST for which kit contains the item(s) needed. The items below may be available in more than one kit, so check the listings carefully.

ITEM NUMBER	PART NUMBER	DESCRIPTION	Qty. Per Motor Assembly			
			9501	9502	9503	9504
1	9556	Adapter Gear	1	1	1	1
2	9552	Motor Bearing Bracket	1	1	1	1
3	9045	Bearing	2	2	2	2
4	9560	#10 Self Tapping Hex Washer Head Screw - Type 23 - 1-3/4" Long	3	3	3	3
5	9550	Motor	1	1	-	1
5A	9551	Motor - High Torque (for use with 23 series steps only)	-	-	1	-
6	9018	Hair Pin	1	1	1	1
7	9017	Clevis Pin	1	1	1	1
8	9553	Linkage Assembly for Motor Assembly #9501	1	-	-	-
9	9565	Linkage Assembly for Motor Assembly #9504	-	-	-	1
10	9554	Linkage Assembly for Motor Assembly #9502 and #9503	-	1	1	-
11	9555	Gear Case	1	1	1	1
12	9561	#6 Self Tapping Hex Washer Head Screw - Type 23 - 3/4" Long	2	2	2	2
13	9298	#10 Self Tapping Hex Washer Head Screw - Type 23 - 1-1/4" Long	4	4	4	4
14	9038	Gear	1	1	1	1
15	9037	Gear Case Cover	1	1	1	1
16	7039	Motor Mounting Plate	1	1	1	1
17	9557	Adapter Gear Shaft	1	1	1	1
18	9559	Clamp Plate - Upper	1	1	1	1
19	9562	Clamp Plate - Lower	1	1	1	1
20	9558	Wire Connector Seal	2	2	2	2

LUBRICATION AND MAINTENANCE SCHEDULE

Clean all mud, salt, and rad grime from step before lubricating. Lubricate all moving parts (bearings, pivot points, slides, clevis pin, and drive linkage ball) every 30 days with a good quality moisture and heat resistant penetrating grease. Kwik-Lube Spray Grease is specially formulated to lubricate Kwik-ee electric steps and is recommended for lubricating all moving parts. See the Parts List for Kwik-Lube ordering information.

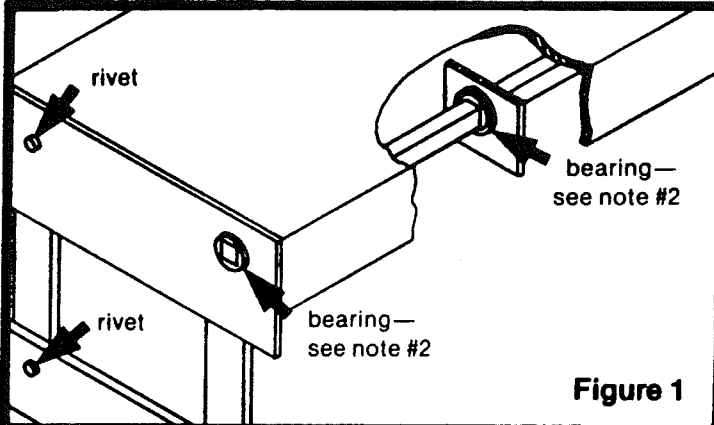

Figure 1

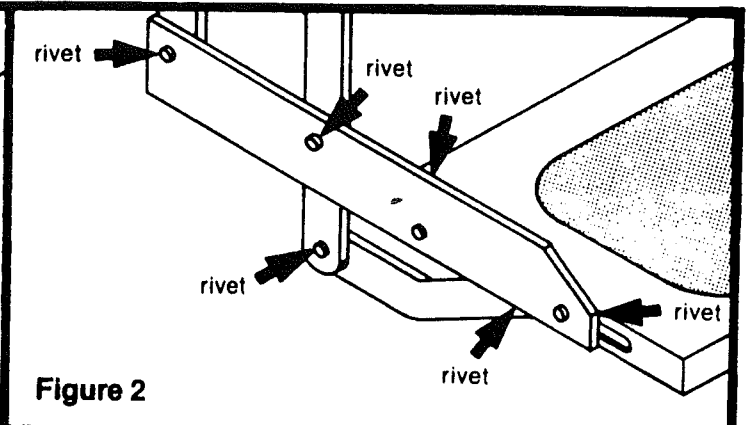

Figure 2

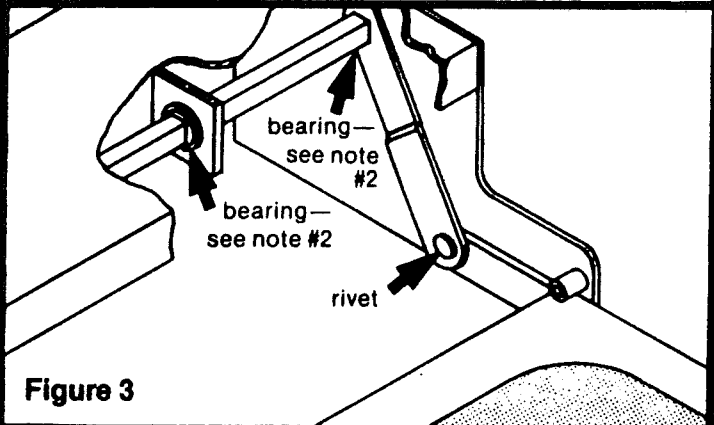

Figure 3

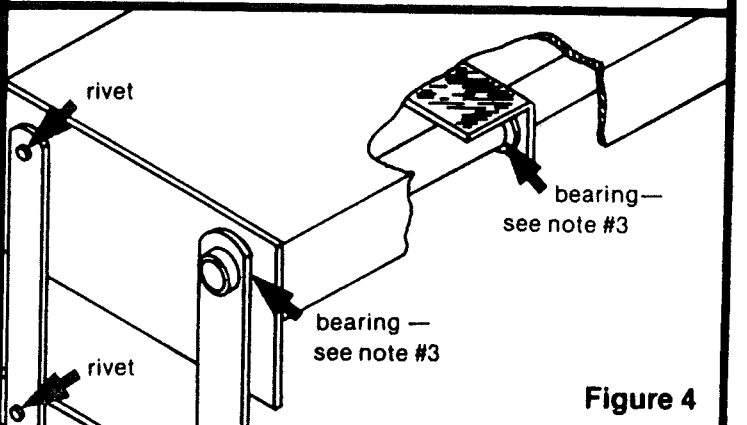

Figure 4

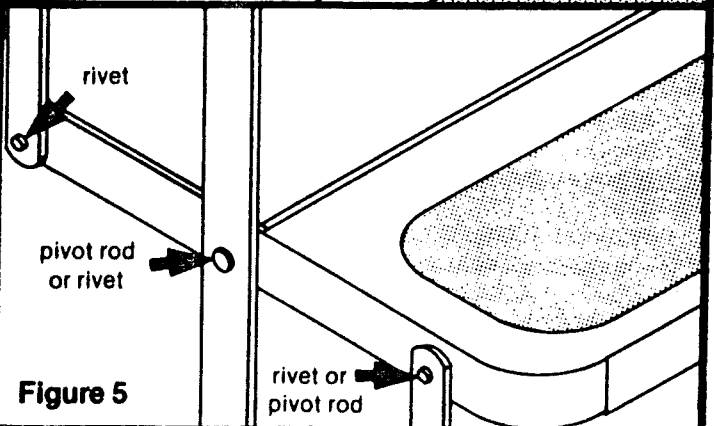

Figure 5

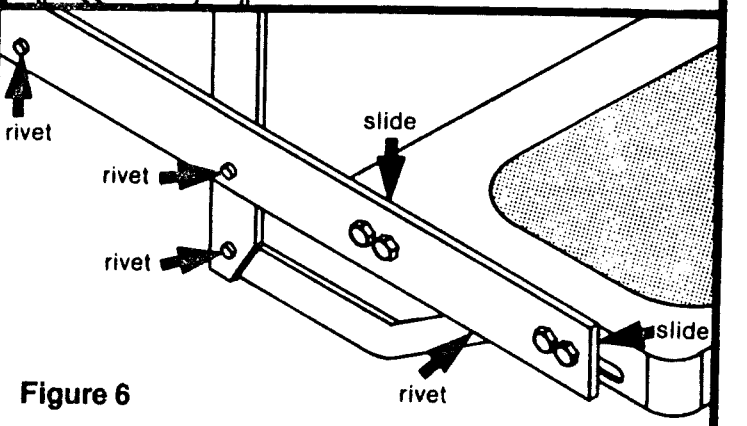

Figure 6

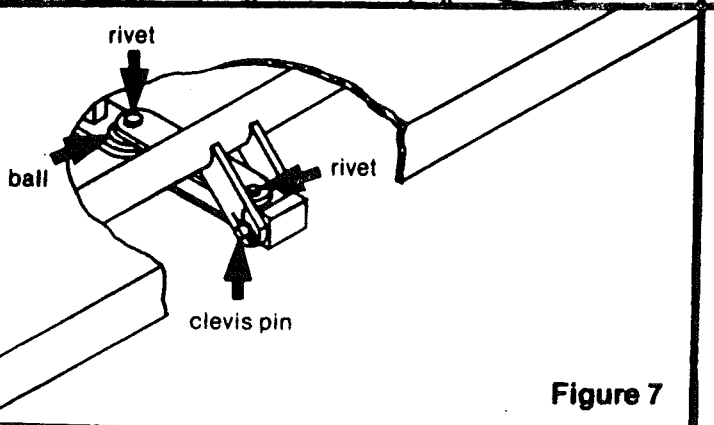
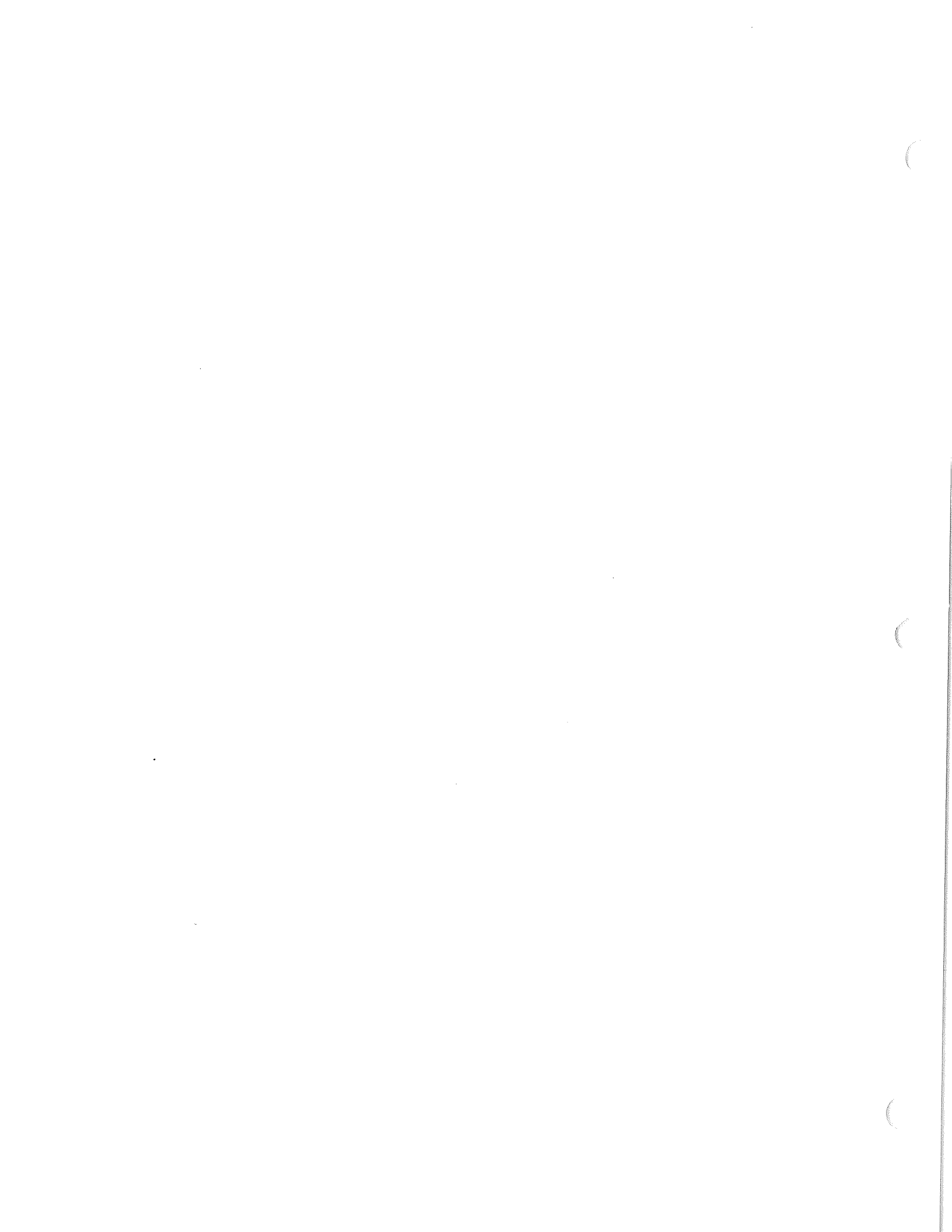

Figure 7

NOTE -

1. Figures are to be used as a general reference only. Some may not pertain to your particular step model. Views are typical to both ends of step.
2. Figures 1 & 3 - square shaft bearing - lubricate around outside and under head of bearing.
3. Figure 4 - 1" O.D. tube bearing - lubricate around drive tube and between head of bearing and drive leg.

NOTES



CAMPING

SAFETY

As always, safety should be one of your top priorities. Make sure you, and everyone traveling with you, can operate the main door and exit window rapidly without light.

WARNING: *The escape window (which is the rear, roadside windows) is opened by pulling the red latch handle inward then sliding the glass and screen forward. The pleated shade is opened by sliding it straight up. The window operation should be checked each trip.*

WARNING: *At each campsite make sure you have not parked in such a manner as to block the operation of the escape window by being too close to trees, fences or other impediments. Scenic views are one reason for traveling, but don't park so the beautiful lake or steep cliff is just outside your escape window.*

WARNING: *Read the directions carefully on the fire extinguisher. If there is any doubt on the operation, you and your family should practice, then replace or recharge the extinguisher. You will find your local fire department will be happy to assist you and answer any questions.*

WARNING: ***DON'T SMOKE IN BED!**
KEEP MATCHES OUT OF REACH OF SMALL CHILDREN!
DON'T CLEAN WITH FLAMMABLE MATERIAL!
KEEP FLAMMABLE MATERIAL AWAY FROM OPEN FLAME!*

We have all heard these warnings many times, but they are still among the leading causes of fires.

Other safety information on the LPG system of your motorhome is located in the Plumbing Section of this manual.

SMOKE DETECTOR

OPERATION AND MAINTENANCE

The PROBE Battery Powered Smoke Alarm operates on the ionization principle of fire detection. That is, the ionization chamber inside the unit monitors the air to detect particles of combustion present as a result of smoke.

When the small current inside the ionization chamber is decreased, indicating the presence of smoke, the alarm sounds.

Probe Smoke Alarms only **warn** of a situation which may be potentially hazardous. No smoke alarm can eliminate the hazard.

Your PROBE Smoke Alarm requires very little maintenance.

The unit should be vacuumed occasionally to remove dust. Simply hold the nozzle of the vacuum near the alarm cover and the suction will remove any dust particles. (DO NOT TRY TO OPEN THE ALARM OR PLACE THE VACUUM NOZZLE INSIDE THE ALARM COVER.)

Battery Replacement

When the battery begins to weaken, a warning "chirp" will sound at least twice per minute for about a month. To replace the battery simply remove the alarm from the mounting bracket (turn counter-clockwise), remove the old battery and replace it.

*Model #105 with silencer provides a 15 minute pause button to quiet nuisance alarms. Perfect for confined areas (cooking areas, furnace rooms, etc.)

LP Leak Test

In the refrigerator inspection compartment, a LP gauge has been plumbed in the gas line. To check for leaks, open the LP tank valve, then turn appliances off. The gas pressure should not drop any more than 2 inches of water column pressure in a 30 minute time span. Further information is located in the plumbing section of this manual.

OVERNIGHT STOP

In time you will develop a knack for spotting wonderful little roadside locations by turning off the main highway and exploring. There are many modern recreational vehicle parks, including State, County and Federal parks with good facilities, where you may obtain hookups of electrical, water and sewer connections. Directories are published which describe in detail these parks and tell what is available in the way of services and hookups.

Overnight or Weekend Trips

On overnight or weekend trips, chances are you will not use up the capacity of the sewage holding tank, deplete the water supply, or run down the batteries which supply the living area 12 volt current.

Longer Trip

On a longer trip, when you have stayed where sewer connections and utility hookups were not available, it will be necessary for you to stop from time to time to dispose of the waste in the holding tank and replenish the water supply. Many gas stations (chain and individually owned) have installed sanitary dumping stations for just this purpose. Booklets are available which list these dumping stations.

When you stop for the night, your Airstream motorhome is built to be safely parked in any spot that is relatively level and where the ground is firm. Your facilities are with you. You are self-contained. Try to pick as level a parking spot as possible.

Hydraulic Leveling Jacks

Some models are equipped with hydraulic leveling jacks that can be deployed. Complete instructions are included with the Owners Packet. Be sure to read the directions completely prior to operating the jacks. The jacks will be able to level your unit in most modern campgrounds. However, their capabilities are limited, and in some situations you will have to use planks to level the coach.

All you need to do to enjoy the self-contained luxury is to:

1. Turn on LP gas supply and light appliance pilots if required.
2. Turn on water pump and open faucets until air is expelled from the system.

Before moving on, turn off the LP gas and water pump, check your campsite, both for cleanliness and also to be sure you haven't left anything behind. Make sure everything is properly stowed.

WINTER TRAVELING

Traveling in your motorhome during the cold winter months can be a most exhilarating experience.

There are, of course, certain precautions which must be taken as you would in your home in low temperatures.

WARNING: *Always shut off the LP gas when gasoline is added to the fuel tank.*

Some states do not allow LPG to be turned on while moving. While traveling in these states you must use your common sense. How cold is it? How long will it be before you can turn the heat back on? Is the temperature dropping or rising? Remember, the wind chill factor when driving 50 MPH will cause the interior of the motorhome to cool much faster than when it is parked.

1. You must have a plentiful supply of propane gas.
2. If your stay is longer than overnight, you should endeavor to have 120-volt electricity available. The batteries, fully charged, will not last more than about 15 hours in freezing weather. Of course, you can run your generator to recharge the batteries, or even use the generator continually.
3. Minimize use of electricity if 120 volt power source is not available.
4. Leave cabinet doors, bed doors and wardrobe doors slightly open at night to allow circulation of air in and around all furniture components.
5. Use propylene glycol type antifreeze in waste and drain water tanks to prevent freezing. Quantity of antifreeze needed will vary with ambient temperature and the amount of liquids in tank.
6. For extended stays in cold weather, insulate the water line outside the motorhome. You should remember that low temperatures in combination with high winds cause an equivalent chill temperature much below what your thermometer is reading. For instance, with an outside temperature of zero degrees, and the wind velocity of 10 miles per hour, the equivalent chill temperature is minus 20° F.

Condensation

It is also important to guard against excessive humidity inside your motorhome during winter campouts. When windows and window frames fog up or "sweat," it means that there is too much moisture in the air. Moisture comes from water vapor and water vapor is the direct result of water evaporating.

Many things such as baths and showers, boiling foods, washing dishes, washing clothes, even breathing, contribute to evaporation. The inside air can only absorb so much of this moisture before it becomes saturated. At this point it can hold no more, and any additional water vapor condenses back to liquid water in the form of droplets on any available cool, solid surface. Temperature has a direct effect on the air's saturation point. Cold air holds less moisture than warm air. For this reason, the air immediately adjacent to cold outside walls and windows cools down and causes water vapor to condense and form moisture droplets, even though warmer inside surfaces are still dry.

The best way to keep condensation under control is to reduce moisture producing activities. It is important to provide adequate ventilation and keep the air circulating as much as possible.

Use your exhaust fans to remove moisture before water vapor mixes with the air. Open windows slightly once in a while, while operating fans, to bring in drier outside air and aid in overall air circulation. In extremely cold weather, when outside ventilation is not practical, it may be necessary to use a small dehumidifier to aid in reducing condensation.

There is no substitute for common sense in cold weather.

Note: The Airstream motorhome is built as a recreational vehicle and is not intended as a permanent dwelling or for more than temporary use in sub-freezing temperatures.

EXTENDED STAY

Making a long trip is not very different from making a weekend excursion. Since everything you need is right at hand, you are at home wherever you go. When packing for an extended trip, take everything you need, but only what you need.

Some models are equipped with Hydraulic Leveling Jacks that can be deployed. Complete instructions are included with the Owners Packet. Be sure to read the directions completely prior to operating the jacks.

When you plan to stay in the same place for several days, weeks or months, you will want your motorhome to be as level as possible. Check the attitude with a small spirit level set on the inside work counter. If a correction is necessary, then you must first level from side to side. This can be done most easily by driving up a small ramp consisting of 2" x 6" boards tapered at both ends. **WE DO NOT RECOMMEND PLACING TIRES IN A HOLE FOR LEVELING.**

Hook Up to Water by attaching a 1/2" minimum high pressure water hose to the city water service, or the hose from the water reel if so equipped.

Plug the Electrical Cable into the City Power Service. Be sure you have the wire grounded and have the proper polarity. See Electrical Section for technical details.

A Cable TV Hookup is located on the roadside rear corner of the motorhome. It is already wired into the existing system, so the exterior connection is all that is required.

To operate the Generator simply start the generator at the control panel. After the generator has run a couple of minutes, an automatic relay will close and current from the generator will be supplied to the 120-volt circuit breakers. This is indicated by the AC power light on the control panel starting to glow. Operating the generator for about one hour each day will normally keep the battery charged.

Hook your Waste Drain Hose into the Sewer Disposal Facility and attach to the drain outlet in your motorhome. For details on this procedure see Drain and Waste System Section.

Turn on the gas supply and light the oven pilot. Lighting a top range burner to bleed any air from the system will make it easier to start other appliances.

When you stay for extended periods where electric or water hookups are not available, you must make regular checks on the condition of your 12 volt battery and the contents of your water tank. Carry drinking water in a clean bucket to refill your tank. When your waste tank nears capacity, move your motorhome to a dumping location.

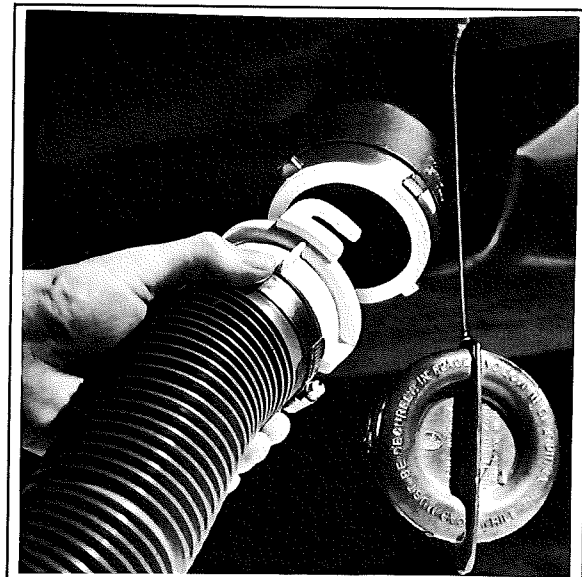

Sewage Outlet

NOTES

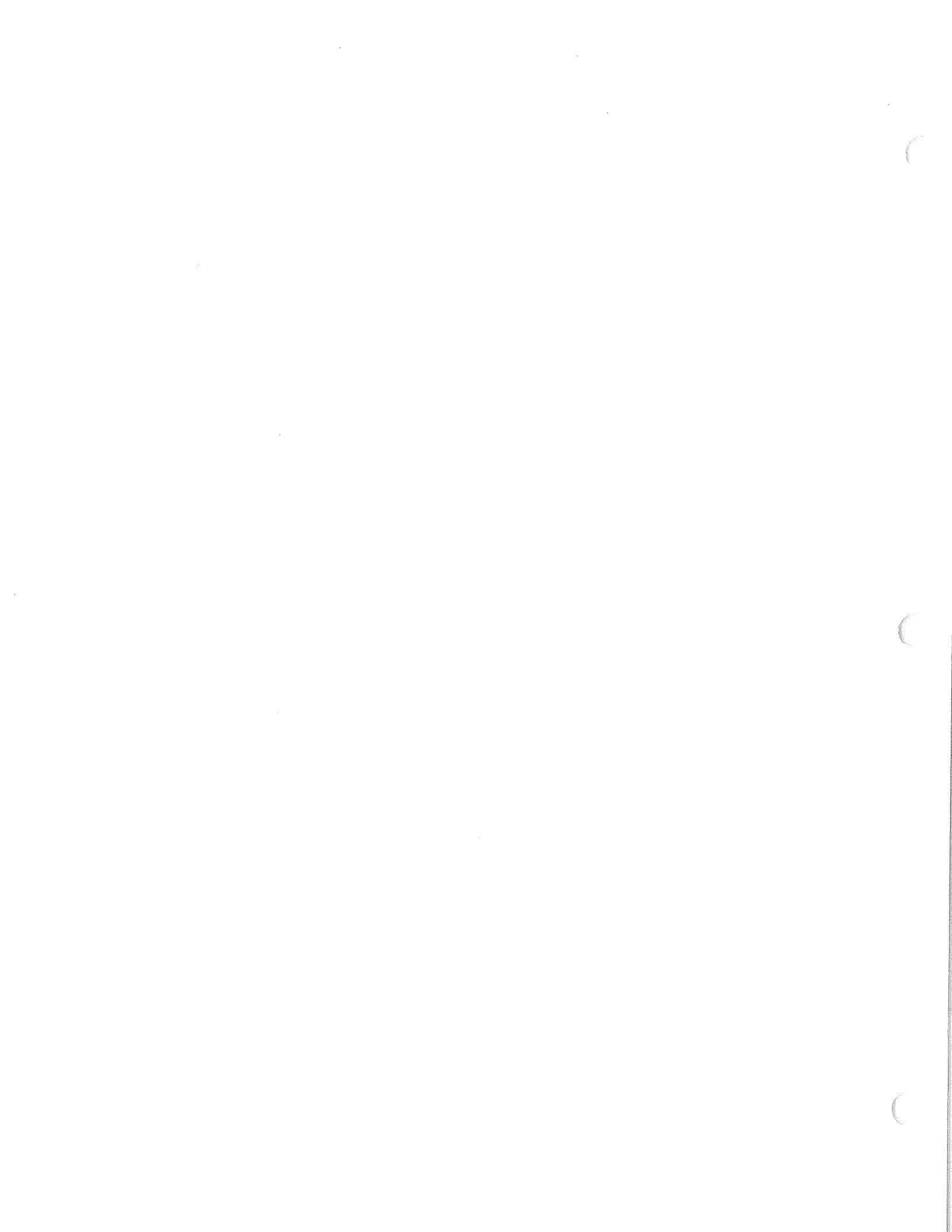

EXTERIOR

The side walls and roof of your Airstream Land Yacht motorhome are laminated fiberglass. There is no magic to caring for your motorhome. As a general rule of thumb, we recommend the motorhome be washed about every four weeks and waxed in the spring and fall. To make sure your new unit is always protected, you should wax it immediately or have your dealer wax it just prior to delivery. In industrial areas cleaning and waxing should be done on a more frequent schedule.

ALWAYS CLEAN YOUR MOTORHOME IN THE SHADE OR ON A CLOUDY DAY WHEN THE SKIN IS COOL. Oil, grease, dust and dirt may be removed by washing with any mild non-abrasive soap or detergent. Cleaning should be followed by a thorough clean water rinse. Spots and streaks may be prevented by drying the unit with a chamois or a soft cloth.

After cleaning and drying, a good grade of non-abrasive automotive paste or liquid wax will increase the life of the finish, especially in coastal areas where the finish is exposed to salt air, or in polluted industrial areas. It will also protect the shell from minor scratches and make subsequent cleaning easier.

It is important to remove sap, gum, resin, asphalt, etc., as soon as possible after they appear by washing and rewaxing. Sunlight and time will bake-harden these materials, making them almost impossible to remove without heavy buffing. If asphalt remains on the motorhome after washing, use a small amount of kerosene on a rag and wipe the spots individually, being careful not to scratch the finish.

It is recommended that the caulking and sealant used in external seams and joints such as window frames, light bezels, beltline and rub-rail molding, etc., be checked regularly. If this material has dried out and becomes cracked or checked, or if a portion has fallen out, it should be replaced with fresh material to prevent possible rain leaks. Caulking and sealing material is available from your Legacy dealer.

Main Door Lock

The door lock on your motorhome operates in the same manner as the locks used on most automobiles. Locking the latch actually disengages the linkage between the handles and the latch. This prevents forced entry by using large pliers on the lock handle.

We urge you to keep an extra set of keys for both the door lock and the ignition hidden somewhere on the exterior of the coach. We probably receive a dozen calls a year from people who have lost keys or locked them in the coach.

Occasionally you might find the latch catch, shown in the open position below, out of time. This simply means it has been bumped and has flipped to the closed position when the door is still open. To re-time, hold the door handle in the open position, then pull out and down on the latch catch. It should flip to the open position as shown in the illustration.

1. Mounting plate,
Door Lock
2. Lock Handle, Inside
3. Latch Catch
4. Keeper, Rod Linkage
5. "E" ring, Tumbler
Installation

(Lock assembly as viewed
from inside of door with
cover plate removed.)

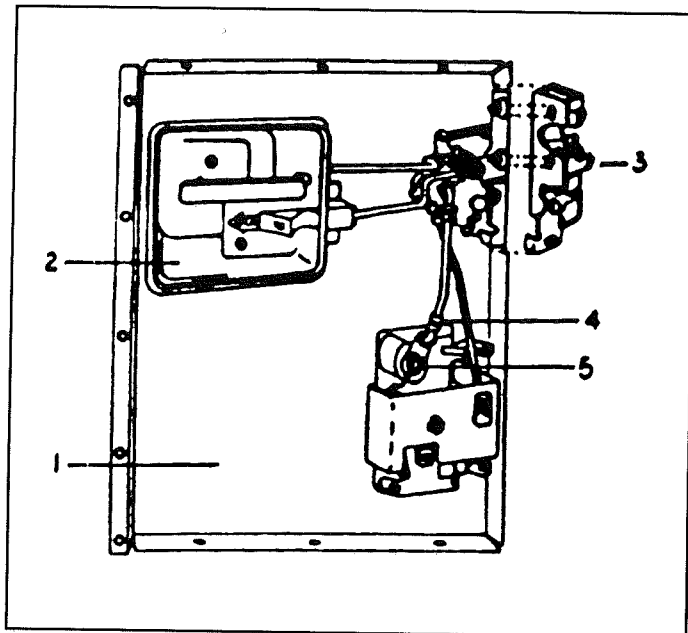

Access to the linkage mechanism of the lock is gained by removing the two screws holding the lock handle and the center panel of the inside door skin. This will expose the door lock assembly, as shown in the illustration.

The tumbler is replaced by removing the inside lock handle and the center panel of the inside door skin so the lock assembly is exposed. Insert key into tumbler then remove the "E" ring (item #5 on Illus), being careful it is not lost.

EXTERIOR COMPONENTS

On the curbside of the motorhome, forward of the main door, is a large compartment door enclosing the LP tank.

The roadside of the motorhome has the big compartment up towards the front and the generator compartment behind that. Towards the rear is another smaller storage compartment.

The hood release latch is located by the driver's left knee. Under the hood is the generator, coach batteries, and the Spartan automotive breakers.

The Airstream serial number is located above the generator. It will match the number on the Airstream Warranty you receive about 6 weeks after purchasing the motorhome.

The legal Vehicle Identification Number used for titles and other legal documents is on the drivers door post. This number is the Spartan chassis serial number.

Keyless Door Entry System

Operation:

Interior

Both driver and main door can be locked manually or electrically. To lock electrically depress the left side of the door lock switch on the dash. To unlock press the opposite side of the switch. Only hold the switch momentarily until you hear the "clunk" indicating the system was activated. The dash switch does not operate the compartment locks.

Exterior

To lock the system, push the last two key pads (7/8 and 9/0) at the same time. All doors will be locked.

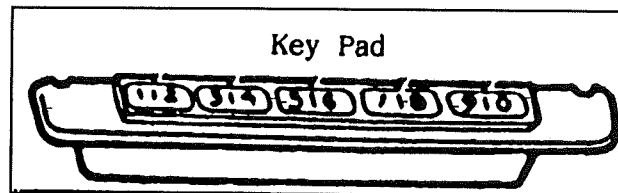

To unlock the main door, enter the five digit code provided to you by your dealer on a code card. If more than five seconds elapse between button pushes the system will time out, requiring you to start over.

To unlock the cab door - enter the five digit code then within 5 seconds depress 3/4.

To unlock the compartment doors - enter the five digit code then within 5 seconds depress 5/6.

Note: The compartment door locks will not be in sequence to operate electrically unless the key slots are in the horizontal position.

Owners can also select and program a second personal code. To program this second code, you first have to enter the code from your code card. Then, within five seconds, depress the 1/2 button. Then, within five seconds of each other, depress five buttons in any sequence you desire. This button sequence will be retained by the system as the second code. To erase the second code, simply enter the warranty card code, depress button 1/2, and wait six seconds. This allows you to loan or share your motorhome with another party without exposing your master code.

The system can be overridden with a key if a power failure or electronic failure should occur. We recommend a key be hidden on the exterior of your coach. We are not necessarily worried about a mechanical failure as much as a memory failure. Sometimes names and numbers can totally skip your mind, only to return later. A hidden key could prevent an embarrassing situation.

CAUTION: *Do not punch the switch with a car key, ball point pen, pencil, etc.* Hard objects may damage the push buttons. Each button should be pressed on the vertical line between the numbers because there is only one switch under each button.

KEYLESS ENTRY SYSTEM

SERVICE INFORMATION

There are four major electrical components used to operate the keyless entry system.

Key Pad Dash Switch Drive Motor Control Module

The CONTROL MODULE is the heart of the system. Twelve volt power from the engine battery supplies power to the module, and is distributed by the control to the key pad, drive motor and aisle lights.

The control module and the connections shown on the wiring diagram are located under the galley back against the wall.

If any failure occurs the first check is to look for power at the key pad. Does it light when a key pad is depressed? If not, check the engine battery for charge. If it is okay check for 12 volt positive and negative. Perform this check at the red and white wires providing power to the module as shown on the wiring diagram.

Listen! Depress key pads 7/8 and 9/10. Can you hear the drive motor trying to work the plunger?

Does the dash switch work the lock when the key pad doesn't? If this is the case depress each key pad button one at a time. Pause long enough for the light illuminating the pad to go out between each test. Did each pad make contact indicated by the light being activated?

The dash switch is a simple grounding device. Grounding either wire going to the switch should extend or retract the lock plunger.

CAUTION: Do not ground both wires simultaneously to prevent damage to the control module.

When performing simple tests like these it is important to realize the drive motor is polarity sensitive. This means either wire to the motor may be negative or positive according to the mode. When the mode is reversed (open to close or close to open) the wire that was positive becomes negative and the negative becomes positive.

The drive motor can be tested by providing positive and negative current to the blue and pink wires. Just touching the wires will be enough to activate the motor. Switch the polarity to the wires. Did the drive motor reverse?

Performing these simple tests will isolate 95% of any problems. Don't let the number of wires at the control module scare you. Close examination will show we've only used a few of the functions the module is capable of performing, and the only wires you need to be concerned about are those shown on the following wiring diagram.

KEYLESS ENTRY

COLOR	FUNCTION
Black-Light Blue	Courtesy lights
Light Green-Yellow	
Black	Ground
Light Blue	Key pad
Light Blue-Yellow	
Light Green-Red	
Purple-Yellow	Compartment unlock
Pink-Black	Lock all doors
Pink-Orange	Unlock drivers door
Pink-Yellow	Lock input
Pink-Light Green	Unlock input
Yellow-Black	Key pad
Yellow	
Red	
Brown	
Black-Pink	Input transmission
Red-Orange	Unlock main door
BLK-White	12 volt power in
Pink	Input ignition

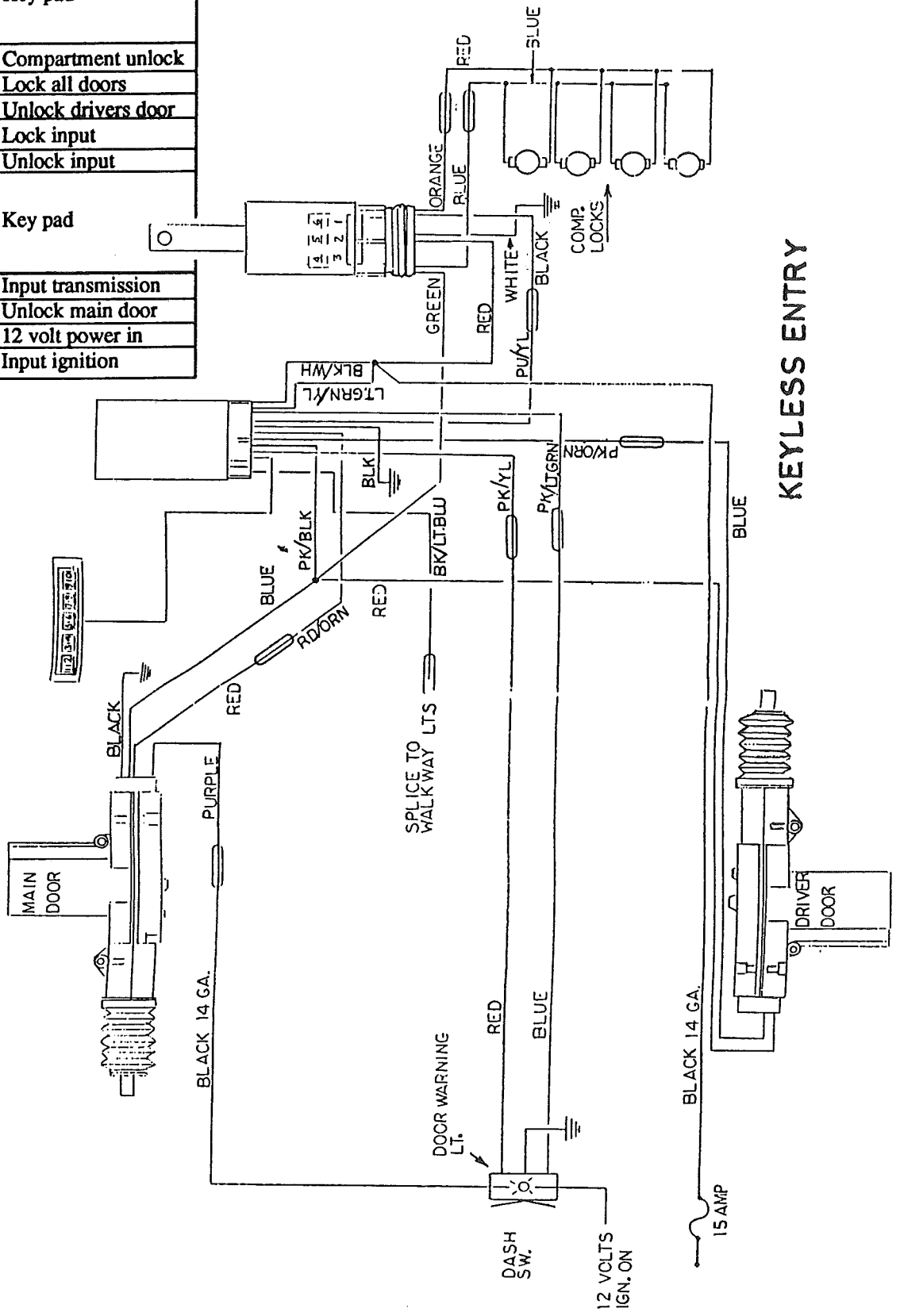

KEYLESS ENTRY

NOTES



INTERIOR

The luxurious interior of your Airstream motorhome has been designed for comfort, convenience, durability and appearance. An understanding of the operational procedures and maintenance techniques of the interior appointments will add to your pleasures, as well as to the long life of your motorhome.

Lounges

To convert the Deluxe Sofa into a bed, it is only necessary to grasp the top of the back rest and pull it toward the aisle of the motorhome. The back rest will raise and pivot out over the seat, becoming the front section of the bed.

Dinette

The dinette is hinged to the wall and is supported by one folding table leg. To make into a bed, the front of the table is lifted slightly, the release latch is depressed on the leg bracket, and the leg is then folded up against the bottom of the table leaf. Velcro will hold it up in position. Raising the front of the table leaf further allows it to be unhooked from the wall. The leaf will then swing out and down onto the support ledges on the front of the dinette seat. The back rests are then laid on the table leaf to complete the bed.

Cocktail Chairs

The cocktail chairs have two adjustments. As you sit in the chair, one lever will protrude on the left side. Releasing this lever allows the chair to rotate.

On the right side is another lever. Releasing this lever will allow the chair to slide forward and backward.

CAUTION: Rotating the chair when it's slid back against the wall can damage the upholstery. Position the chair so it isn't chafing when in transit.

Fabric Cleaning

All material should be professionally dry cleaned to remove any overall soiled condition. These materials may be spot cleaned, however, using the cleanability code instructions as listed. Sample swatches are furnished to our dealers. The dealer will be able to give you the cleaning code and part number for the fabrics used in your particular motorhome.

The following are the cleanability code instructions for the various fabrics used in the Airstream motorhomes:

Cleanability Codes

CODE W-S

Fabric care. Spot clean this fabric either with a mild solvent or a water-based cleaning agent. When using a solvent or dry cleaning product, follow instructions carefully and clean only in a well-ventilated room. Avoid any product which contains highly toxic carbon tetrachloride. You may also use an upholstery shampoo product or the foam from a mild detergent. With either method, pretest a small area before proceeding. Use a professional furniture cleaner when an overall soiled condition is reached.

CODE S

Fabric care. Spot clean, using a mild, water-free solvent or dry-cleaning product. Carefully follow instructions on such product. Clean only in a well-ventilated room. Avoid any product containing carbon tetrachloride, which is highly toxic. Pretest small area before proceeding. Use a professional furniture cleaner when an overall soiled condition is reached.

CODE W

Fabric care. Spot clean, using the foam only from a water-based cleaning agent, such as mild detergent or non-solvent upholstery shampoo product. Apply foam with a soft brush in a circular motion. Vacuum when dry. Pretest small area before proceeding. Use a professional furniture cleaner when an overall soiled condition is reached. The above code was designed by the manufacturer of the fabric.

CAUTION:

Never remove cushion cover for separate cleaning or washing. Any tumble cleaning method can destroy the backing, shrink or otherwise damage upholstery.

SMOKING WARNING

Keep your furniture and family safe from fires caused by careless smoking. Do not smoke when drowsy. Remove immediately any flowing ash or a lighted cigarette which falls on furniture. Smoldering smoking material can cause upholstered furniture fires.

Drapes

Use the following procedures to remove drapery panels for cleaning:

Front Wrap Around Drapes

1. Remove screw securing rear end of drapery track to wall, both roadside and curbside.
2. Slide draperies to the rear until they are clear of track.
3. After reinstalling drapes, replace screw in end of track.

CAUTION: All drapery materials and mattress covers must be professionally dry cleaned.

To prevent excessive wear to drapery linings, blinds must be secured at the bottom and slats turned vertically when driving long distances.

Shades

The shades are operated in the same manner as most venetian blinds. Pulling down on the rope raises the shade. Swinging the rope to one side prior to releasing it will secure the shade in position.

A feather duster, or the soft-bristled brush often found as part of vacuum cleaner attachments, are recommended for cleaning the blinds and pleated shades.

The mini blinds can be spot cleaned with soapy detergent. However, you must be very careful or you may find yourself washing each individual slat so they'll match.

The longevity of the pleated shades in the rear will be increased if the shades are in the up position when your vehicle is stored.

Carpet

The carpet can be cleaned with any good commercial carpet cleaner, or with a detergent and water. **HOWEVER, BE CAREFUL NOT TO SOAK THE CARPET WITH WATER.**

Counter areas

The counter areas around the sink are of a high-pressure laminate and can be cleaned with soap and water, or you can use a common solvent on tough spots. Be sure no abrasive cleaner is used, as there is the possibility it could scratch the surface. A protective pad should always be placed under hot utensils.

Walls/cabinets

The vinyl walls of the motorhome can be wiped with any mild household cleaner. The wood grain panel also has a vinyl covering for easy care. The cabinet doors and framework are hardwood, so any good furniture polish can be used.

Drawers

Drawer removal - pull drawer out to stop then depress white nylon tab(s) in center of drawer stops.

Drawers with metal runners on each side are removed by extending completely then lifting up on the front of the drawer and pulling it out of the track.

NOTE: The drawers under the rear double beds will contact the wall before coming free from the metal runners - hold drawer out against the wall and slide the metal runners under the bed until the drawer is free.

CAUTION: Do not use any abrasive material on the vinyl covered walls.

Bathroom

CAUTION: The lavatory bowl and countertop in your bathroom are made of a special ABS long-wearing, light-weight, high-strength plastic material or cultured marble. When cleaning, use soap or detergent only. **NEVER USE SCOURING POWDER.**

Always re wax the ABS plastic surfaces after each heavy cleaning with a good grade paste wax (without solvents or cleaners). The wax will protect the surfaces from discoloration and stains. When you first purchase your motorhome, Airstream recommends that you give all ABS plastic surfaces a heavy coating of paste wax. This will assure easier cleaning and lasting beauty.

Stainless Steel Sink

Stainless steel sinks are not harmed by boiling water. However, salt, mustard, mayonnaise and ketchup can cause pitting. Stubborn stains will yield to paste made of water and a slightly abrasive household cleaner. Be sure to work in the direction of the polish lines on the steel to keep the original finish. Fingerprints are sometimes a problem. They can be minimized by applying a cleaner that leaves a film of thin wax: simply wipe it on and remove the excess with a dry cloth, or one moistened with a little wax cleaner. The surface should always be washed before wax is applied. Regular cleaning will prevent build up of scale and film. Ordinary soaps or detergents are best for routine cleaning of the stainless sinks. Rinse thoroughly with warm water and wipe dry with a cloth to avoid streaks and spots.

Shower Stall

To clean your ULTRA/GLAS shower stall unit, use warm water and one of the stronger liquid detergents. Do not use abrasive cleaners; they may scratch and dull the surface of your ULTRA/GLAS unit. Stubborn stains can be removed with solvents such as turpentine, paint thinner or acetone. Restore dulled areas by rubbing with an automotive-type liquid cleaner, then put the soft glow back into your ULTRA/GLAS unit with a light application of liquid wax.

WARNING: Do not wax the floor of the stall without using a bath mat afterward to prevent a dangerous slippery floor condition.

NOTES

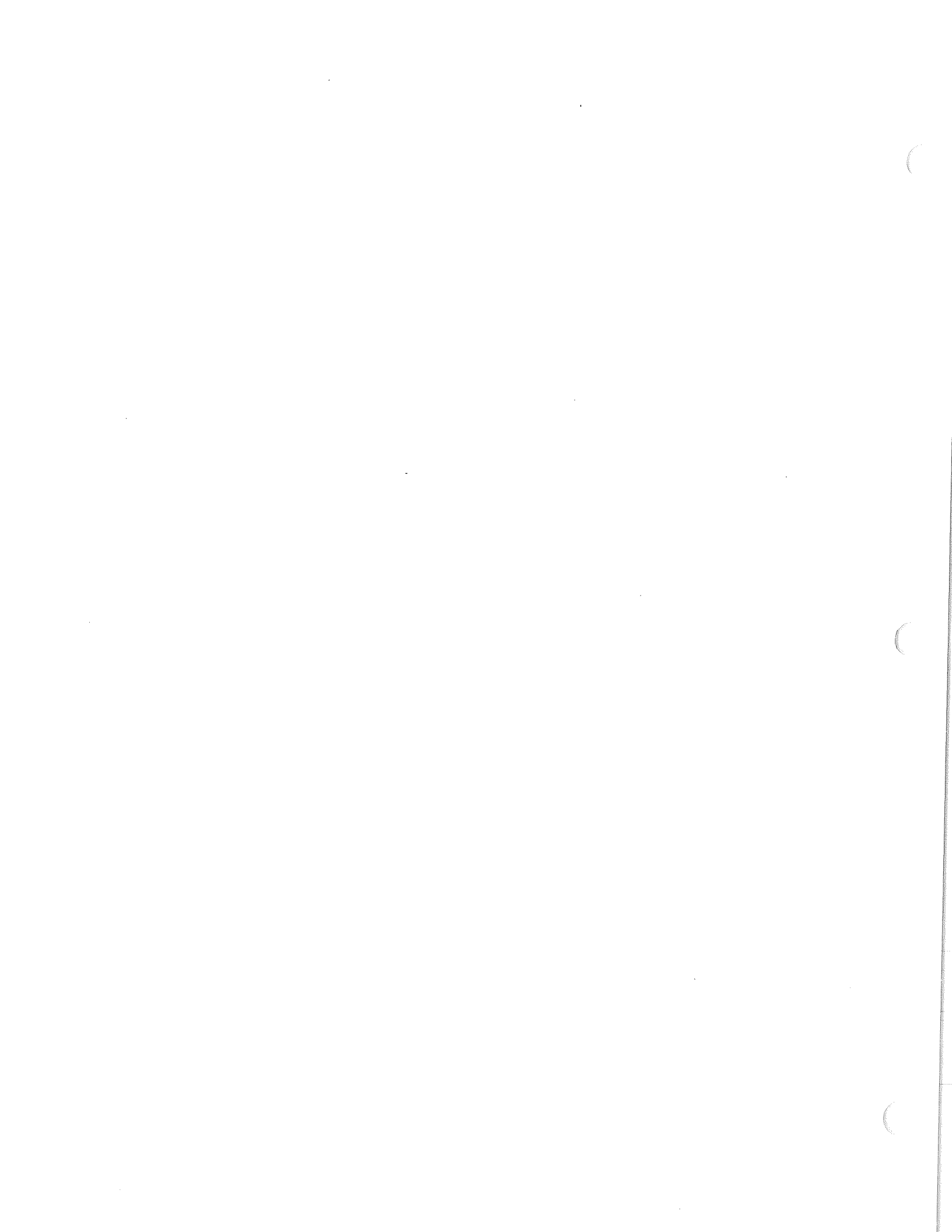

PLUMBING

LPG SYSTEM

Your motorhome is equipped with a permanently mounted tank for LPG (Liquid Petroleum Gas). LPG burns with a clean blue flame. There are two basic types of LPG in common usage: Butane and Propane. Butane is widely used where temperatures are normally above freezing the year round, and Propane is used where subfreezing temperatures are common, since Butane freezes at 32°F as compared to -40°F for Propane. **ALL OF THE ORIFICES IN THE LPG APPLIANCES ARE OF THE UNIVERSAL TYPE WHICH WILL BURN EITHER FUEL.** How long a full tank of gas will last is dependent on usage. In cold weather, when you are using the furnace, large amounts of hot water, and cooking extensively, you will naturally use more than you will in warm weather, when you may do limited cooking. On the average, with normal cooking and other appliance use, you can probably count on one month of usage from the tank.

If you have allowed the tank to run out, air may have gotten into the lines. In this event the air must be forced out through the lines by gas pressure before you can light the pilots. Hold a match to the pilot of the appliance closest to the tanks until it lights and stays lit. Then move to the next closest, etc.

WARNING:

All pilot lights and appliances must be turned off during refueling of motorhome fuel tank and permanently mounted LPG tank. Gas lines should be checked periodically for leaks with ammonia free soapy water. Do not use open flame.

CAUTION:

Moisture in the LPG tank will cause a malfunction of the regulator in controlling proper pressure. This may result in the flame lifting off the burner, or the flame may go out frequently. Many refueling stations will add approximately 1/4 to 1/2 gallon of alcohol to lower the moisture temperature. Moisture will then pass through the regulator without the formation of ice crystals.

WARNING:

If gas can be smelled, appliance pilots fail to stay on, or any other abnormal situation occurs, shut off tank valve immediately and call on a qualified LPG service center or Airstream Service Center.

LPG Regulator

The LPG regulators used on Airstream motorhomes are designed for low pressure service, with a normal outlet pressure setting of 11.5 water column. Only personnel trained in the proper procedures, codes, standards, etc., should service regulators.

Have the regulator inspected each time the tank is refilled. Make sure the regulator vent opening on both first and second stage regulators does not become plugged by mud, insects, snow, ice, paint, etc. Vents must remain open.

Replace any regulator that has had water in the spring case, or shows evidence of external corrosion, or corrosion inside the spring case. Closely examine regulators directly connected to the container valve by means of a solid POL adapter (horizontal mounting) for signs of corrosion. (An Airstream Service Center is recommended for this service.)

BASIC RULES FOR SAFETY

WARNING: DO NOT store LP containers within vehicle. LP containers are equipped with safety devices that vent gas should the pressure become excessive.

WARNING: DO NOT use cooking appliances for comfort heating. Cooking appliances need fresh air for safe operation. Before operation open overhead vent or turn on exhaust fan and open window.

A warning label has been located in the cooking area to remind you to provide an adequate supply of fresh air for combustion. Unlike homes, the amount of oxygen supply is limited due to the size of the recreational vehicle, and proper ventilation when using the cooking appliances will avoid dangers of asphyxiation. It is especially important that cooking appliances not be used for comfort heating as the danger of asphyxiation is greater when the appliance is used for long periods of time.

WARNING:

Portable fuel burning equipment, including wood and charcoal grills and stoves, shall not be used inside the recreational vehicle. The use of this equipment inside the recreational vehicle may cause fires or asphyxiation.

WARNING:

A Warning Label has been located near the LP gas container. This label reads: DO NOT FILL CONTAINER(S) TO MORE THAN 80% PERCENT OF CAPACITY. Overfilling the LP gas container can result in uncontrolled gas flow which can cause fire or explosion. A properly filled container will contain approximately 80 percent of its volume as liquid LP gas.

WARNING:

Do not bring or store LP gas containers, gasoline or other flammable liquids inside the vehicle because a fire or explosion may result.

WARNING:

If you smell gas:

1. Extinguish any open flames, pilot lights and all smoking materials.
2. Do not touch electrical switches.
3. Shut off the gas supply at the tank valve(s) or gas supply connection.
4. Open doors and other ventilating openings.
5. Leave the area until odor clears.
6. Have the gas system checked and leakage source corrected before using again.

WARNING:

LP gas regulators must always be installed with the diaphragm vent facing downward. Regulators that are not in compartments have been equipped with a protective cover. Make sure that regulator vent faces downward and that cover is kept in place to minimize vent blockage which could result in excessive gas pressure causing fire or explosion.

LP TANK INSTALLATION

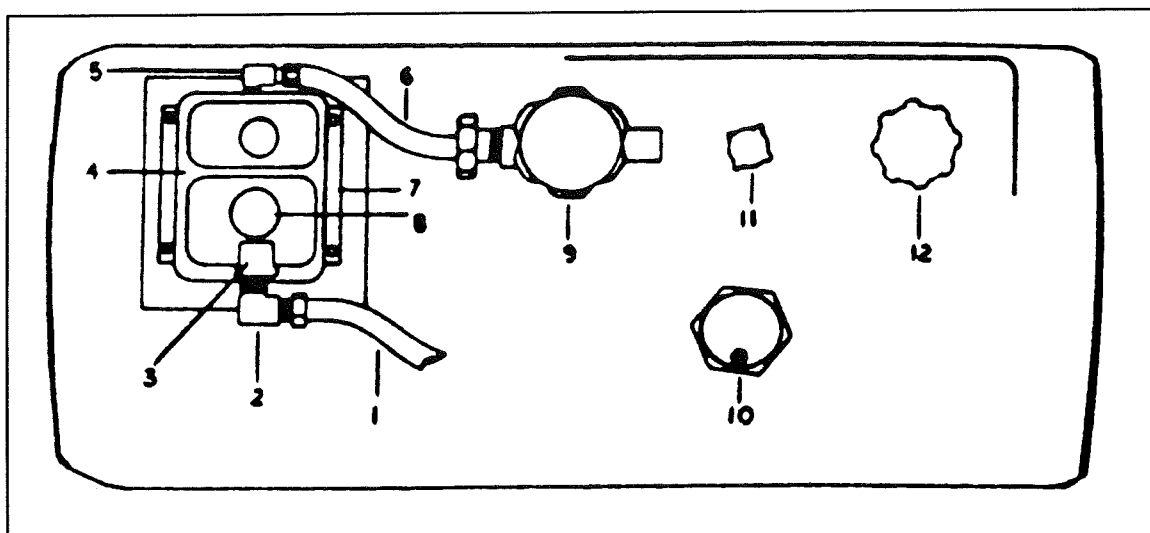

- | | |
|------------------------------------|--|
| 1. Hose regulator to main gas line | 7. Mounting bracket, regulator |
| 2. Street el 1/2 MPT | 8. Cap, second stage pressure adjustment |
| *3. Vent | 9. Valve, main shut off |
| 4. Regulator, two stage | 10. Gauge |
| 5. Street el 1/4 MPT | 11. 10% valve |
| 6. Hose, gas bottle to regulator | 12. Valve, fill |

***WARNING:**

Check vent each time bottle is filled to make sure it is clear of obstructions.

Gas Regulator Removal/Replacement

1. Shut off main gas supply at the tank.
2. Remove the plastic protective cover from the regulator assembly.
3. Using two wrenches, one to hold the line fitting and one to turn the flare nut, disconnect the regulator from the flexible rubber line.
4. Disconnect the regulator from the tank fitting. Remove regulator.
5. To replace, reverse the removal procedures.

LPG System Pressure Check

Use a pressure gauge. (See Illustration)

This gauge is calibrated to read in "inches of water column pressure" or kilopascals. Our reference figures will always use the American inches of water column.

It can be viewed by opening the exterior refrigerator access compartment. Since it's permanently plumbed into the system, it constantly monitors the pressure.

The optimum pressure is 11.5 inches of water column. The pressure should never be less than 11.0, nor higher than 12.0 inches with all appliances operating or off.

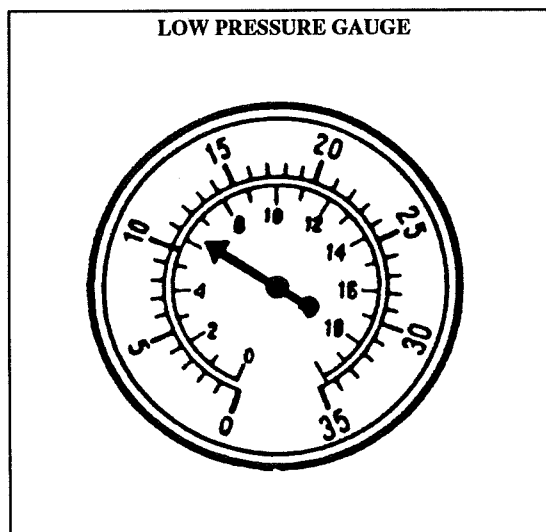

To use the gauge to check for leaks:

- Turn all appliances and pilots off.
- After two minutes shut main valve off at LP tank
- Loosen fitting at main valve so high pressure is released from line between tank and LP regulator
- * • No pressure drop should be seen on the gauge within 10 minutes.

***NOTE:** The American Gas Association allows some gas leakage through valves. Reference their regulations A-119 and Z-21.21. This allowable seepage may cause some pressure drop within the 10 minute check period.

***WARNING:** Have a professional check your system if you have any doubts.

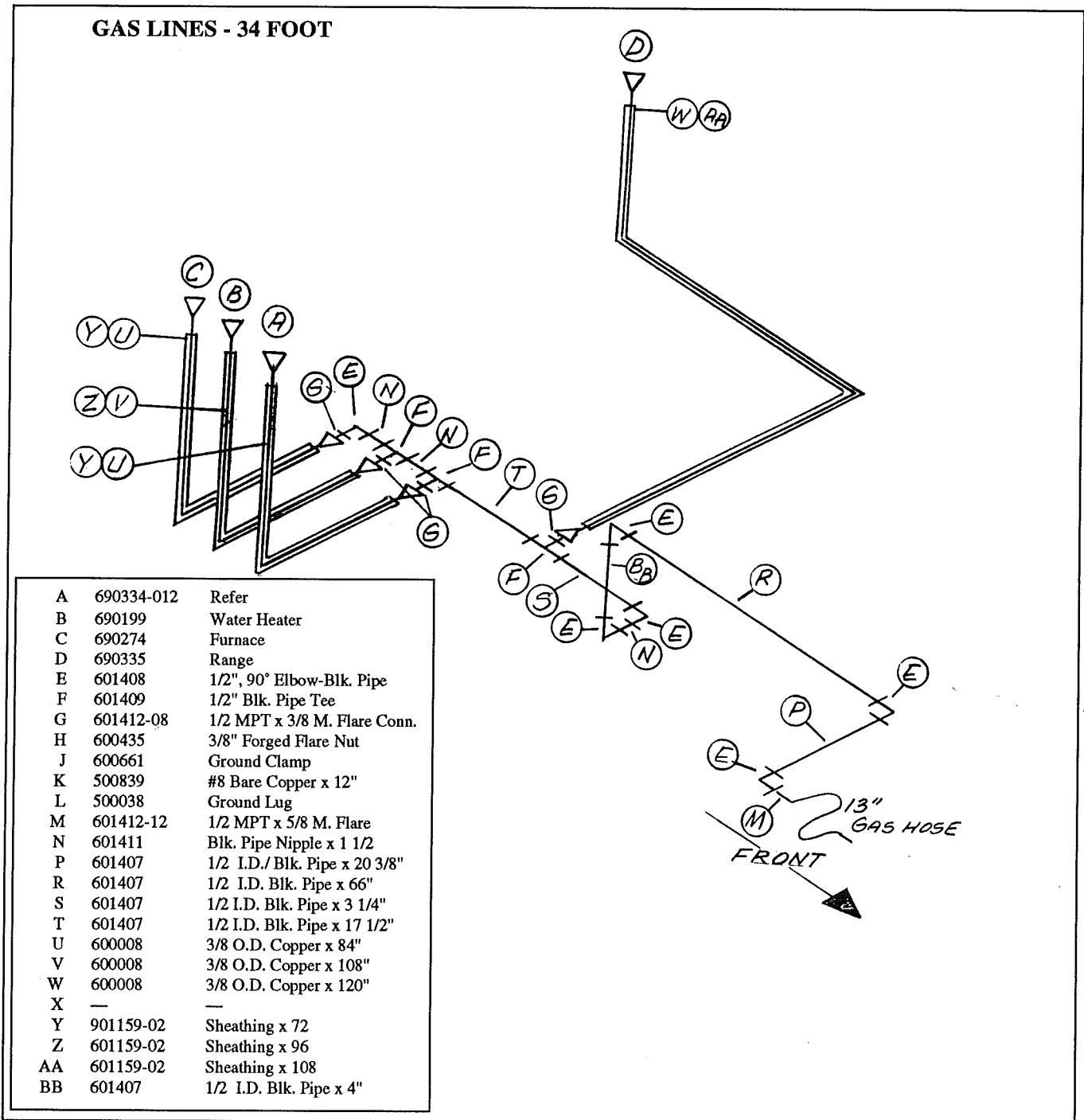

WATER SYSTEM - SELF CONTAINED

Fill the water tank by opening the exterior door marked water fill and remove largest screw cap. A garden hose can now be inserted. It's a good idea to let the water run through the hose for a short time to flush it out. Experienced Rvers usually fill their tanks with "home" water to avoid strange water that may be distasteful to them.

The amount of water in the tank may be checked on the Monitor Panel, or you may fill the tank until water overflows out of the fill.

Turn water heater by-pass valves to normal flow, open valves A and C. Close valve B. For winterizing B would be opened while A and C are closed. Access to the valves is under the kitchen sink way back towards the wall. A mirror and flash light may be helpful to locate them the first time.

Open the hot side of the galley or lavatory faucet and turn on the water pump switch located on the monitor panel. For some time the open faucet will only sputter. This is because the water heater is being filled and air is being pushed out through the lines. Once the water heater is full a steady stream of water will come from the faucet. Now open a cold faucet. It will sputter for a short time, but will soon expel a steady stream. All other faucets can now be opened until all air is expelled.

Once the system is filled with water and the faucets closed, the water pump will shut off. When a faucet is opened the pump will come back on automatically. If the faucet is just barely open it is normal for the pump to cycle on and off rapidly.

**WATER HEATER
BY-PASS VALVES**

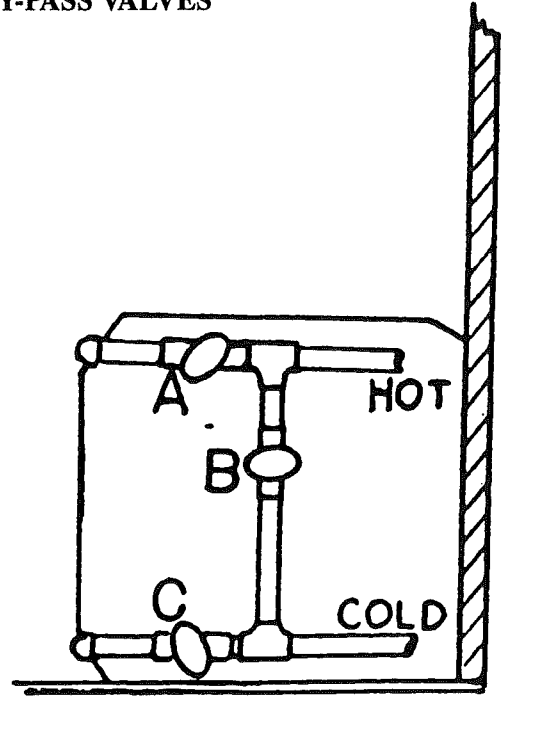

CAUTION: The water pump must be turned off when hooked up to city water supply and when you leave your Airstream unattended.

WATER PUMP AND FILTER

The water pump and filter are located under the front dinette seat. Access is gained by removing the drawer under the seat. (See drawer removal in the Interior Section of this manual) The filter screen should be cleaned periodically to prevent accumulation of dirt and sand. To remove the screen, disconnect the rubber hoses from both ends, separate the screen housing, remove the screen, clean and replace.

To Disassemble Pump Filter

- *1. Remove screw through top.
2. Pull top from base. Do not damage "O" ring seal.
3. Remove screen to clean or replace.
4. Lift "O" ring from its cavity. Lubricate with silicone grease.
5. Assemble by reversing above procedure.

*Some may have tops that screw into base.

Cleaning Water Storage Tank

1. Prepare a sodium hypochlorite solution using potable water and household bleach (5 1/4 to 6%) in the ratio of 1/4 cup bleach to 1 gallon of water. (Common household bleaches are Purex and Chlorox.)
2. Pour 1 gallon of hypochlorite solution for each 15 gallons of capacity into the empty water tank.
3. Add enough potable water to completely fill the water system.
4. Allow closed system to stand for three hours.
5. Drain the hypochlorite solution from the system and refill with potable water.
6. Excessive hypochlorite taste or odor remaining in the water system is removed by rinsing the system with a vinegar solution mixed in the ratio of 1 quart of vinegar to 5 gallons of water.
7. Drain the system and flush with potable water.

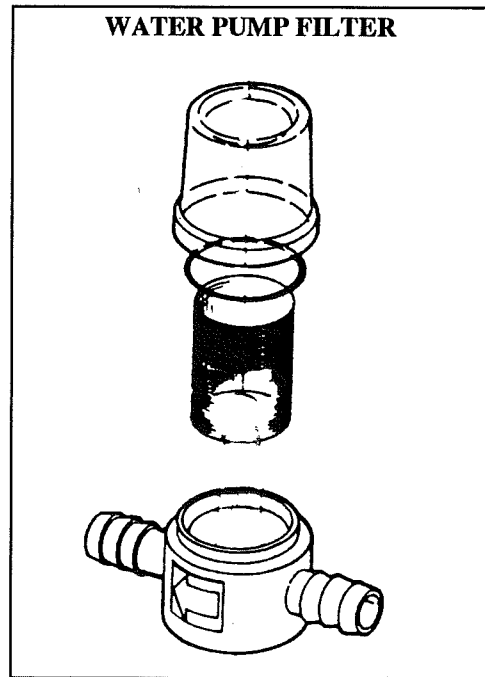

NOTES

WATER PUMP

Manufacturer:

Shur-Flo
1740 Markle Street
Elkhart, Indiana 46514
Phone: 219-294-7581

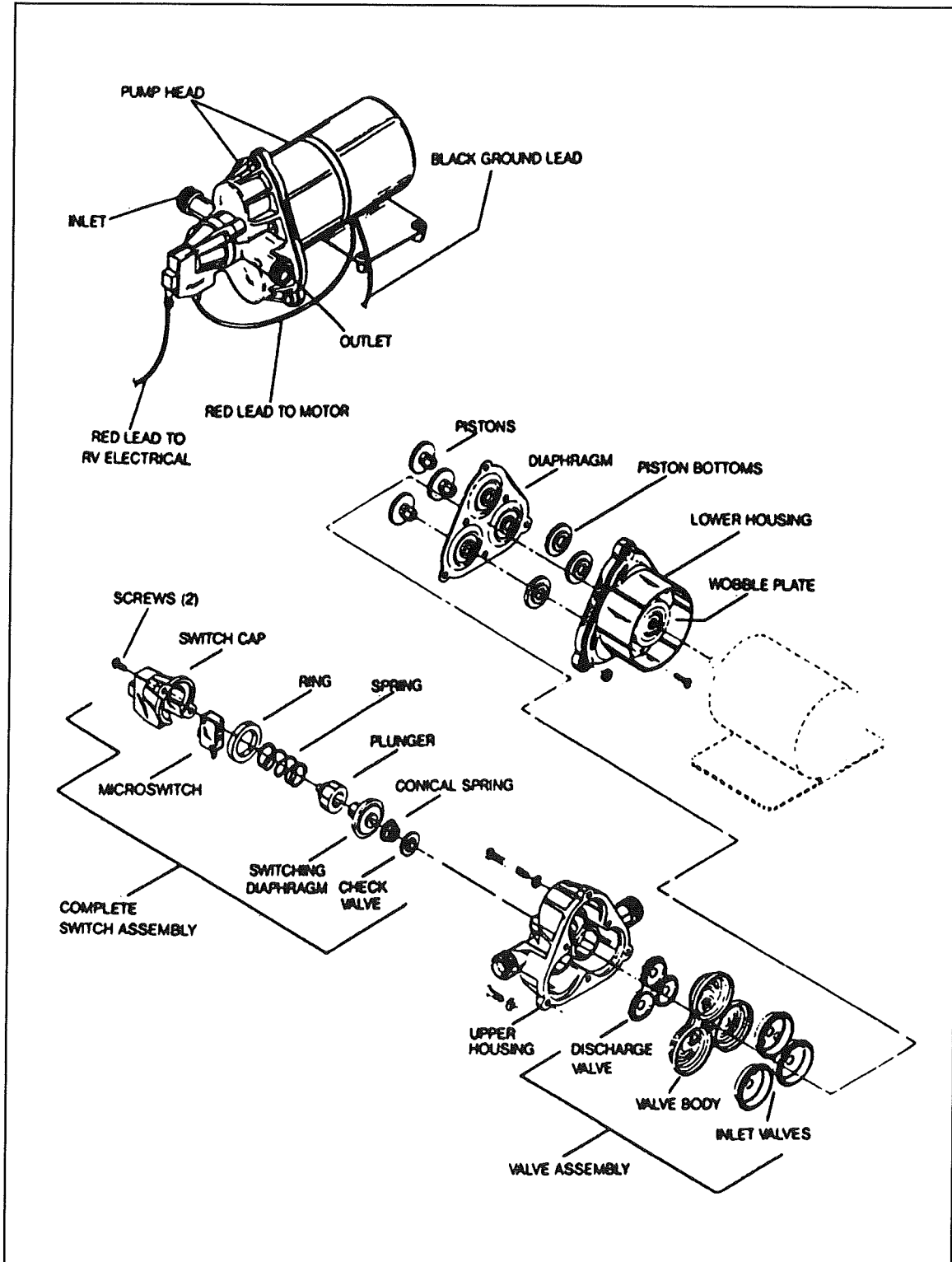

Switch and Check Valve Repair

The check valve, hydraulic switch mechanism and micro switch are accessible by removing the switch cover.

CAUTION: Care should be taken in removing the switch cover screws. Within the mechanism is a spring under compression.

Replacement of Micro Switch

Occasionally the micro switch fails or an electrode is broken off. Proceed as follows: Remove the two screws holding the cap to the main body. Remember, a spring under compression is retained by this cap. With both screws out, allow the spring to extend fully. Then carefully lift off cap and spring. If only the micro switch is at fault, avoid disturbing the hydraulic elements remaining in the head. If examination of the hydraulic parts is required, remove them carefully by pulling. Be sure to note the order of removal.

To replace the micro switch, remove the spring and pull out the black retaining ring. This will allow the micro switch to fall free. Replace parts in the reverse sequence: Micro switch, black retainer, and the spring.

Reassemble cover to the main body. Switch cap may be pointed up or down as desired, providing wire has not been shorted.

Having replaced the micro switch, be careful to rewire correctly.

Note: If the positive wire from the battery is connected to the "B" terminal, the switch is bypassed and the pump cannot shut off. Pressure will build up until the motor stalls. If the proper fuse has been used, it will blow. If a larger fuse than recommended has been used, the motor will stall and may burn out.

Check Valve Problems

Due to contamination from debris or lime build-up, the check valve may fail to properly seat. To correct, clean out the area and replace the check valve element. If checking the check valve with air be certain to moisten the check valve to get an accurate check. The rubber seals more effectively when wet.

Properly Installed, the Pump will:

PRIME: The pump will automatically prime itself.

AIR-LOCK: Pump will not air-lock as the compression stroke is powerful enough to pressurize the entrapped air and force the check valve open.

RUN DRY: Pump will run dry for extended periods without damage.

BATTERY DRAIN: At free flow, the pump draws a mere 7 to 7 1/2 amps.

CHECK VALVE: Built-in check valve prevents back flow and can protect the pump from the dangers of high city water pressure (up to 200 PSI).

FULLY AUTOMATIC: The pump will automatically come on when the faucet or valve is opened. It delivers a smooth, steady flow of water and shuts off automatically when the faucet is closed.

Trouble Shooting

MOTOR DOES NOT OPERATE.

- Is battery discharged?
- Are any wires disconnected?
- Are terminals corroded?
- Is switch in "ON" position?
- Is fuse good?
- Is water frozen in pump head?

MOTOR RUNS BUT NO WATER FLOWS.

- Is water tank empty?
- Are there kinks in the inlet hose?
- Is air leaking into inlet hose fittings?
- Is inlet line or in-line filter plugged?
- If using a filter, check the line just before the filter.
- Is outlet hose kinked?

MOTOR RUNS BUT WATER "SPUTTERS"

Check to be certain that air has been bled off the lines and water heater. Also check for air leaks in the input side of the pump.

PUMP CYCLES ON AND OFF WHEN ALL OUTLETS ARE CLOSED.

The pump will normally cycle (go on and off) when a faucet is partially opened. If, however, it cycles when all valves are closed, check for a leak in the lines. It may be a leaky toilet valve or a dripping faucet. Do not forget to check the outside city water entry valve. It may be leaking.

If no leak can be detected, shut pump off. Remove the output hose where it joins the system (not at the pump). Insert a plug in the hose and clamp it. (You can make a perfect plug from a barb fitting: 1/2" size with a cap tightly screwed on the threads.) Turn the pump switch on. The pump should come on, run a few seconds, and then shut off. If it remains off, the problem is NOT the pump. The problem is in the system. If, however, the pump goes on and off, there may be a problem in the pump.

There may be an internal leak in the pump which allows water to escape from the high pressure area back into the low pressure area. Look for a pump valve held open or a crack in the plastic parts.

PUMP DOES NOT ACHIEVE SHUT OFF

The wall switch may be used for temporary control of the pump. A low battery charge may be the cause. Or the pump switch mechanism may be stuck. Try tapping the switch cap on the end of the pump with the handle of a screwdriver. If the pump appears in all other respects to run normally, but fails to shut off, you may have to replace the switch mechanism.

PUMP HEAD LEAKS

If the pump head leaks, first try to tighten the screws in the pump head assembly until they are snug.

CAUTION: Do not over tighten. The leak may be from a crack in the pump head assembly. If so, then replace.

One cause of the pump head cracking may be water freezing inside the pump head. If the leaking water is escaping back near the motor, check for a leaking or broken piston.

Pump Repair

Screws (A) hold the entire pump head assembly to the motor.

Screws (B) hold the pump head face to the pump head main body.

Screws (C) hold the switch assembly to the front of the pump head.

Screws (A) would be removed to correct a problem in the "drive train" between the motor and pump head.

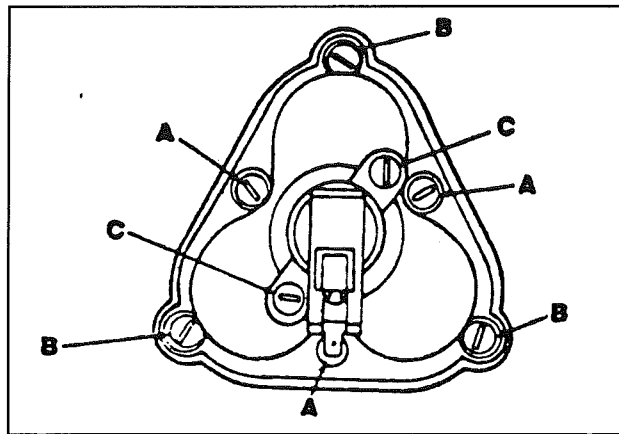

Screws (A) and (B) would be removed to correct a problem in the pump head valves or pumping chambers.

Screws (C) would be removed to correct a problem in the automatic switch or check valve.

PUMP HEAD REPAIR

Motor and drive train area. Rarely does a problem occur in this area of the pump head. If a part does fail, it is quite easily replaced. Just be certain to follow closely the sequence of parts as shown in the figure. Also be careful to align the flat surface in the drive adapter with the flat surface on the motor shaft.

LUBRICATION

If the lubricant appears dried out it should be wiped off the bearing assemblies. A small amount of automotive wheel bearing grease should be applied to both sides of each bearing.

FAILURE TO PRIME

Failure to prime can be caused by the presence of some foreign matter lodged in the valve preventing it from seating. To correct, remove any such foreign bodies.

CAUTION: Do not remove the stainless steel screens. These filter screens should be cleaned without removing them from the plastic housing.

PUMP CHAMBER REPAIR

Replacement of broken piston.

To remove a piston, back out the screw holding the defective piston.

Now lift the corner of the diaphragm and remove the broken piston. Insert the new piston through the diaphragm and slide the retaining ring on. Rotate the piston until it drops into place in the drive plate. Replace the screw and tighten until snug.

CAUTION: Do not attempt to re-use a piston once it has been removed. The plastic stem, if used a second time, may not hold securely. The second thread path removes additional material and there is then no real bite.

REPLACE A DIAPHRAGM

To replace a diaphragm follow the procedure used in removing the pistons. After removing the three pistons the diaphragm is loose and easily removed.

Screws (A) hold the piston.

Screws (B) hold the drive mechanism and should not be removed when replacing piston.

CITY WATER HOOKUP

Two different plumbing systems have been used on the Legacy pusher motorhomes. Earlier models will have two hose connections in the utility compartment. The left one is for connecting to city water and the right is for the black tank flush described below.

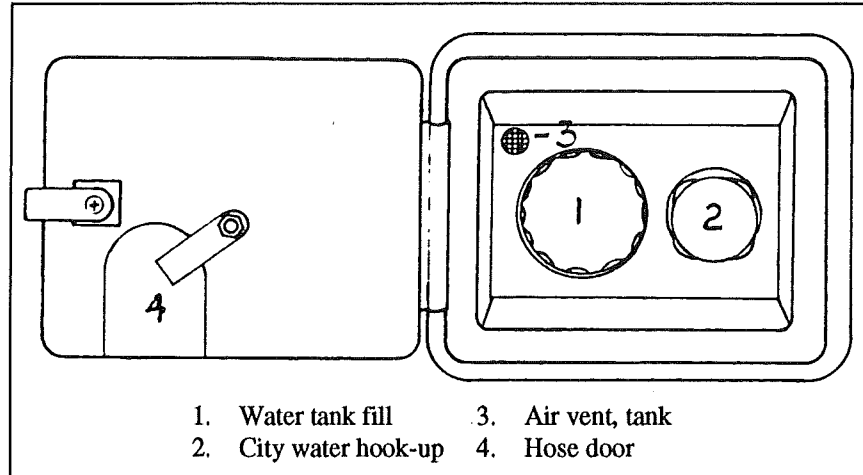

On later models the plumbing was changed to match the rest of the Legacy models. They are identified by having the city water hook-up and water tank fill-up on the side of the coach in a small compartment as shown in the illustration.

Use a high pressure hose of at least 1/2" diameter. It should be one that is tasteless, odorless and non-toxic designed for RV use. The city water inlet is a standard garden hose thread. We suggest you carry two lengths of hose. This way you have the ability to reach hookups further away than normal, plus you have a spare hose should one fail or become damaged unexpectedly. Turn the water heater bypass to the normal flow position as described under self contained.

After hooking up the hose and turning on the city water valve provided in the park, slowly open a faucet. There will be a lot of spurts and sputtering until all the air is expelled from the motorhome system. If the water heater is empty it will take some time before all the air is expelled and you get a steady flow of water at the faucet. Once a steady flow is achieved at one faucet the others should be opened long enough to expel the air in the lines going to them.

During city water operation the water pump switch should be in the off position. A check valve built into the pump protects it from city water pressure.

Your plumbing system has a built in pressure regulator to protect your lines and faucets from extremely high pressures on some city water systems.

BLACK TANK FLUSH

On the left rear lower side is a water hose connector marked "black tank flush". To use, hook-up hose and turn on full force. Within the tank a spray head with a multiplied holed head will spray the interior surface of the tank.

The gate valve should be closed for the first couple of minutes then opened to let the water out in a rush. Repeat as needed.

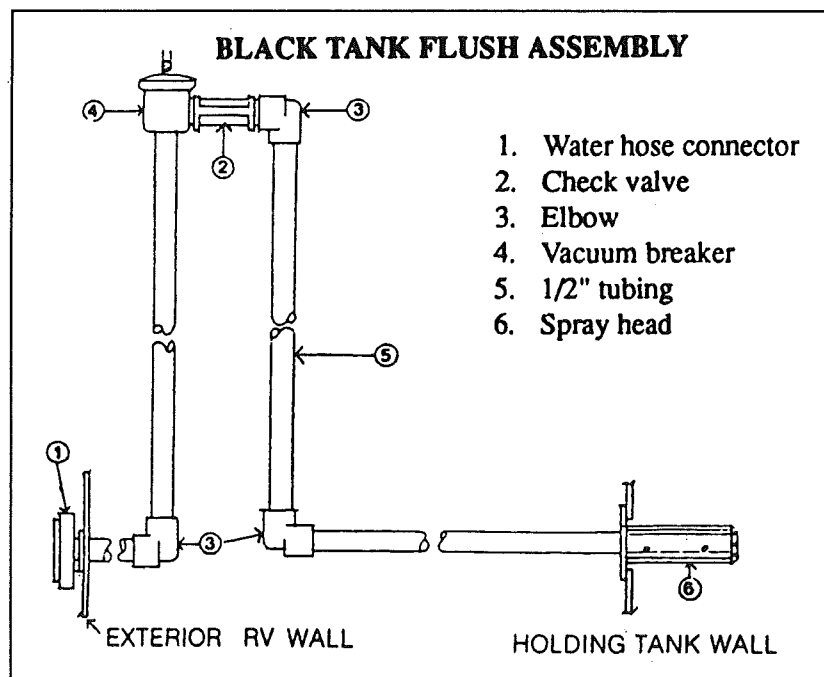

EXTERIOR WATER SERVICE

Also in the utility compartment is a hose connection with a shut off valve. This is plumbed in to the high pressure water system of the motorhome. This is an ideal place to rinse the sand off your feet after going to the beach, cleaning mud off your boots and hundreds of other messy jobs that are better done outside of your motorhome. During freezing weather this line should be drained. Shut off the valve under the slide-out pantry and leave the exterior valve open.

EVERPURE WATER FILTER (OPTIONAL)

The filter is located under the galley sink. It will remove even very fine dirt and colloidal matter, and eliminates most chlorine, phenol and similar distasteful odors and tastes, while delivering sparkling taste-free water for drinking and cooking. The filter is connected to the cold water galley drinking faucet only. The filter will also remove iron and sulphur provided the water supply is chlorinated. super-chlorination will precipitate the iron and sulphur which will then be removed by the QC-2 Filter. To purify any questionable water fill the Everpure Chlorine Disinfectant Dispenser with liquid bleach and add 1/6 ounce (one teaspoonful) per 10 gallons of water in the water tank. The water will remain sparkling clear even to the end of the filter pack life, however, as the minute pores slowly fill up with impurities the flow rate will be gradually reduced. When it becomes too slow for convenience the cartridge can be very simply changed. Follow the instructions on the cartridge. We advise keeping a spare cartridge at all times.

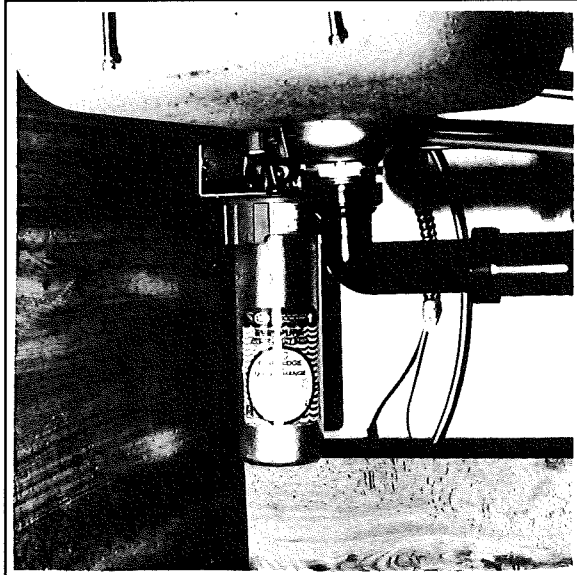

Everpure water Filter

To Remove Used Cartridge:

1. Shut off water by lifting valve handle counterclockwise as far as possible.
2. Turn colored ring all the way to the left. Ring will drop about 5/8".
3. Lift cartridge slightly and turn it further to the left until it can be disengaged.
4. Lower cartridge to disengage it from ring. Discard used cartridge.

To Install New Cartridge:

1. With colored ring in lowered position (turned all the way to the left), orient lug on cartridge with cutout under label on ring.
2. Insert cartridge straight up into ring as far as it will go. Holding colored ring steady, turn cartridge as far to the right as possible, without forcing.
3. The turn colored ring far to right to drive cartridge up into head.
4. To lock ring in place and turn water on, move valve handle down. Be sure handle leg engages ring locking-lug.

FAUCETS

Care and Cleaning

The surface of the faucets will stay bright and resist wear with a minimum of care. Strong detergents may tend to dull the finish. So when cleaning a faucet use only mild soap and water.

The finish on the faucets has been designed to retain its polished appearance without scouring. Stains and dirt remove easily without the use of scouring powders or abrasive polishes and cleaners. Use of such agents may cause scratches which mar the finish, and in time become dirt catchers and unattractive.

GALLEY FAUCET

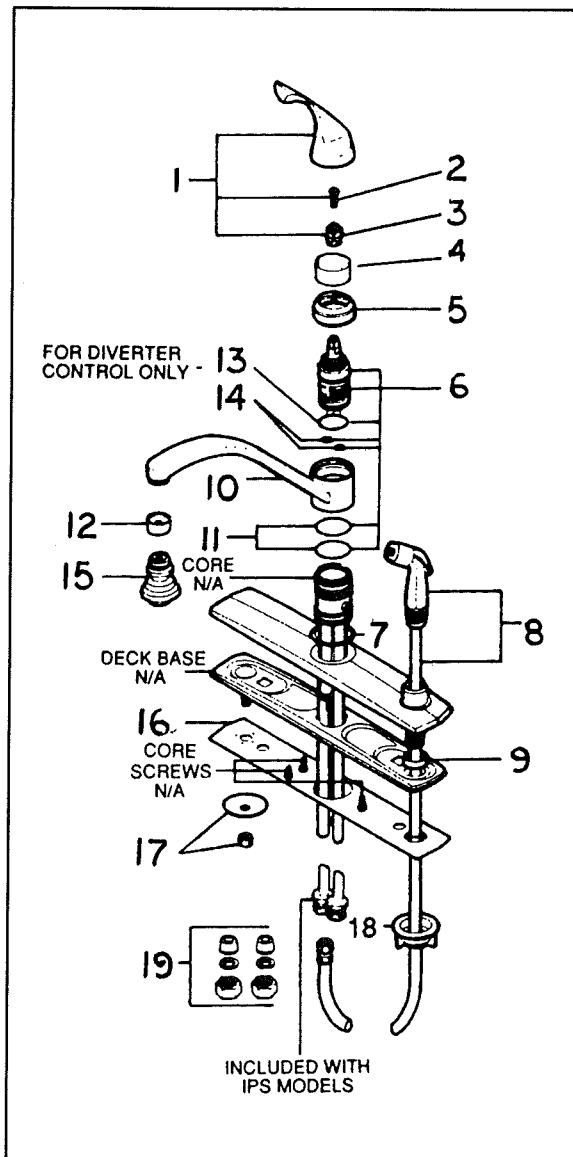

1. Lever handle assembly
2. Screw, handle adapter
3. Handle adapter
4. Bonnet lock ring
5. Bonnet nut
6. Control assembly
7. Bearing hub
8. Spray and hose assembly
9. Spacer ring
10. Spout assembly
11. Spout "O" ring
12. Aerator
13. "O" ring
14. Port seal ring
15. Swivel spray
16. Gasket
17. Mounting nut/washer
18. Wing nut
19. Spacer ring

LAVATORY FAUCET

1. Handle
2. Plug button
3. Handle screw
4. Bonnet lock ring
5. Bonnet nut
6. Port seal ring
7. Control cartridge
8. Lift rod assembly
9. Aerator
10. Undercover pl. screws
11. Under cover plate
12. Gasket
13. Mounting nut/washer
14. IPS fitting

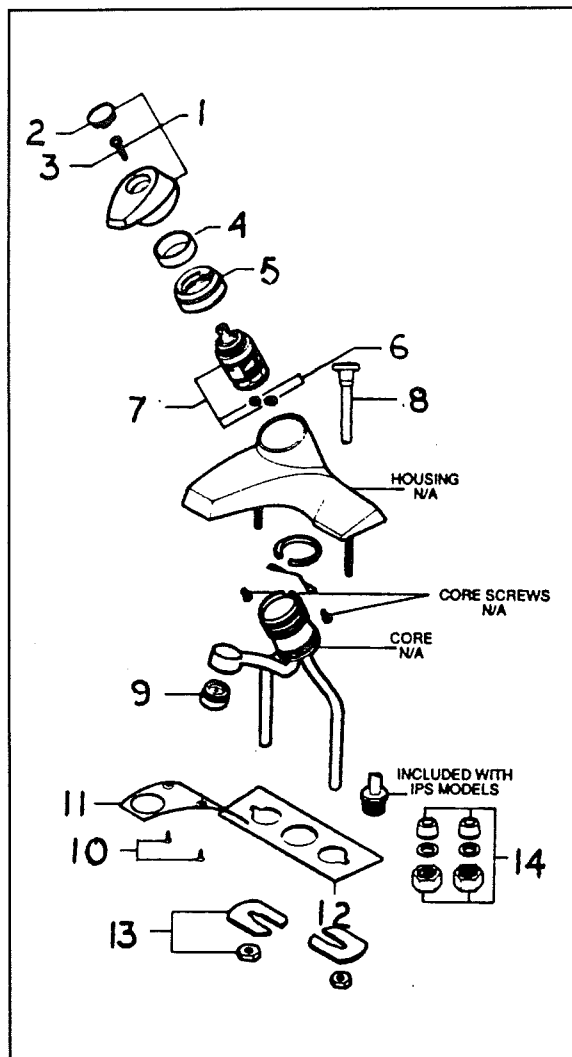

SHOWER MIXING VALVE ASSEMBLY

1. Escutcheon screws
2. Escutcheon assembly
3. Knob assembly
4. Bonnet assembly
5. Sleeve
6. Control repair kit
7. Control assembly
8. Seal and spring repair kit

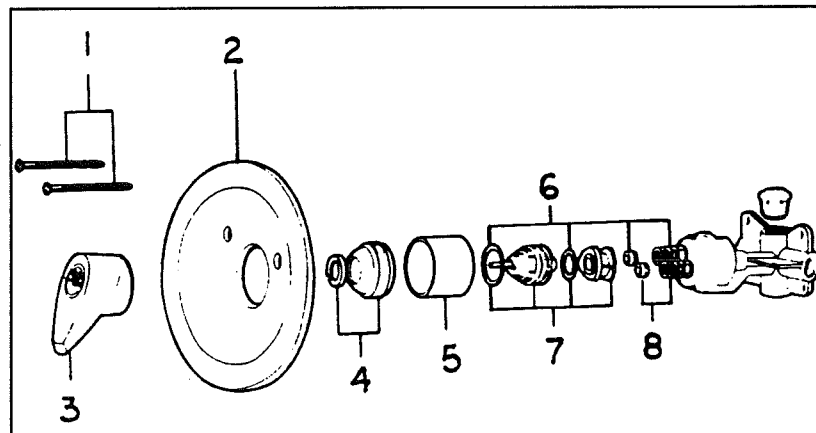

DRAIN VALVES

There are twelve water valves in the high pressure lines of your Land Yacht motorhome:

- Three valves are used in the water heater by-pass system described in the winterizing section.
- Three are located in the utility compartments; one drains the water tank, one drains the cold water lines (deleted on later models with the city water hook-up on the side of the motorhome) and the other provides the shut-off valve for the exterior service.
- Two drain valves are located under the bottom drawer forward of the curbside clothes closet.
- Two more are located under the front of the rear bed under the forward facing drawer. This drawer is removed by pulling out to the stops then lifting the front of the drawer and pull it out of the slides.
- A single drain valve is located next to the water pump under the forward dinette seat.
- Another single valve is located under the slide out pantry. There are release tabs in the slides to allow the pantry to be removed.

*As this manual is being compiled, an optional ice maker is being considered and a valve will be in that line to allow it to be shut off during winter months and for service.

STORAGE AND WINTERIZING

When storing your motorhome for a short or long period, use the same precautions as you would in your own home in regard to perishables, ventilation and rain protection. In addition, for prolonged storage periods, flush out all the drain lines and the holding tanks. Also, drain the entire water system, including the water heater and the water storage tank. Instructions for draining the water system are explained in the following paragraphs on winterizing.

Twice a year, or after a long storage period, we suggest you take your unit into your Airstream dealer for a check-up and cleaning of the gas operated appliances

Living Area

The main consideration in winterizing is to guard against freezing damage to the hot and cold water systems, the waste drain system (including the traps), the waste holding tanks, the water heater and the batteries. To completely winterize your motorhome follow this procedure:

1. Level the motorhome from side to side and front to rear. Open all faucets.
2. Turn the water pump switch to the OFF position.
3. Open all drain valves. One drain valve on all models is located on the water heater exterior and is accessible through the water heater access door.
4. The toilet water valve should be left in open position while draining water.
5. While the water is draining from the system, depress the button on hand spray heads and drain all the water. Unscrew the heads on spray units and store.
6. After the water has stopped running from the drain lines, apply at least 60 lbs. of air pressure at the city water inlet. Be sure the toilet valve and all drain valves and faucets are open and pump outlet hose is disconnected. This can be accomplished at a service station and will force any remaining water from the water heater and remove any water which may be trapped in low areas.
7. Pour a cup of non-toxic antifreeze into the lavatory, sink, and tub drains to prevent freezing water in traps.

8. Be sure to open the waste holding tank drain valves, and drain and flush the tanks thoroughly. (This is very important, as the sewage in the tank, if frozen, could seriously damage the tank.)
9. Remove water filter canister and dump.
10. Remove the batteries from your motorhome and store in a cool dry place where there is no danger of freezing. It is very important for optimum life of your battery to check it periodically and to keep it fully charged. This is especially true in winter months, when the temperature may drop below freezing. If the period of storage is for 30 days or less, you may open the knife switch rather than remove the batteries.

CAUTION: Make sure you close the knife switch prior to operating any appliances or accessories in the motorhome.

Please refer to the battery section for more information on battery maintenance

11. Remove any items (food, cosmetics, etc.) from the interior that might be damaged by freezing, or might damage the motorhome if containers break.

For additional winterizing protection, add non-toxic antifreeze (approved for drinking water systems) to your water lines using the following procedure:

1. Reconnect all lines except the hose to the pump inlet port. Close all drain valves (See Step 3).
- *2. Turn bypass valves to bypass position. Access to the bypass valve in the 34-foot model is in the bottom of the wardrobe just forward of the bathroom. The 30-foot models access is under the galley.
3. Attach a length of hose to the pump inlet port. This piece of hose should be long enough for the free end to be inserted into and reach the bottom of the antifreeze container.
4. Dilute the antifreeze solution in accordance with the manufacturer's instructions.
5. Open all water faucets.
6. Insert hose length into the antifreeze container, turn the pump switch on, and run the water pump until the antifreeze solution fills all water lines and the water heater. Flush toilet. Work shower hand spray while holding down in tub.
7. Shut off the pump and close all faucets.
8. Disconnect the hose length from pump inlet fitting and reconnect water system inlet line.

*To by-pass the water heater for winterizing, close valves A and C and open valve B (See illustration).

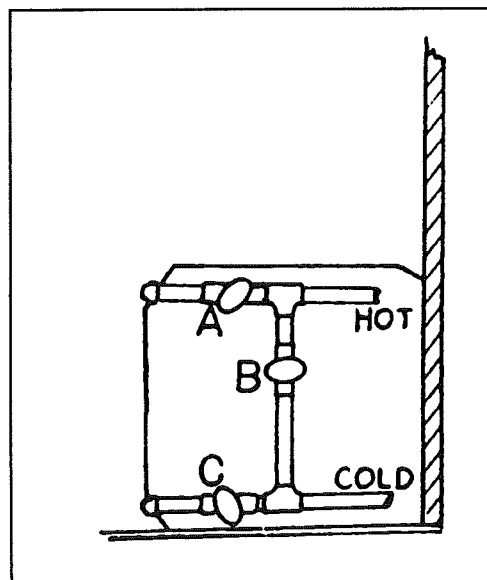

DRAIN AND WASTE SYSTEM

The drain and waste system of your motorhome includes waste holding tanks made from molded plastic. The MAIN HOLDING TANK enables you to use the toilet for several days away from disposal facilities. The waste water from the sink, shower, and bath and lavatory drain into the AUXILIARY HOLDING TANK. Each tank has its own dump valve; however, both tanks drain through a common outlet. Therefore, you need to make only one connection when hooking up in a trailer park with sewer facilities.

Monitor Panel

Check your monitor panel frequently. When the MAIN HOLDING TANK is completely full, sewage cannot be emptied from the toilet bowl. If the AUXILIARY HOLDING TANK is overfilled, drain water will "backup" into the tub and cause an unpleasant cleaning job. Never drain the tanks at any place other than an approved dumping station.

To empty both tanks, attach the sewer hose by pressing the bayonet fitting onto the outlet adapter and rotate clockwise until it feels solid and secure. Attach the outlet end of the hose to the sewage outlet, making sure that the hose is placed so that it will drain completely. The dump valves are located on the lower rear roadside corner of the motorhome. Pull the dump valve handle out as far as it will go and wait until the tank is drained. If the auxiliary tank is drained after the waste tank, the soapy water will help keep the sewer hose and outlet clean.

BLACK TANK FLUSH

The main holding tank must be flushed out until all paper and waste material is removed. Close the dump valve and refill the tank with 5 to 10 gallons of clean water and repeat until clean.

In the utility compartment on the left rear lower side is a water hose connector marked "black tank flush." To use, hook-up hose and turn on full force. Within the tank a spray head with a multiple-holed head will spray the interior surface of the tank.

The gate valve should be closed for the first couple of minutes, then opened to let the water out in a rush. Repeat as needed.

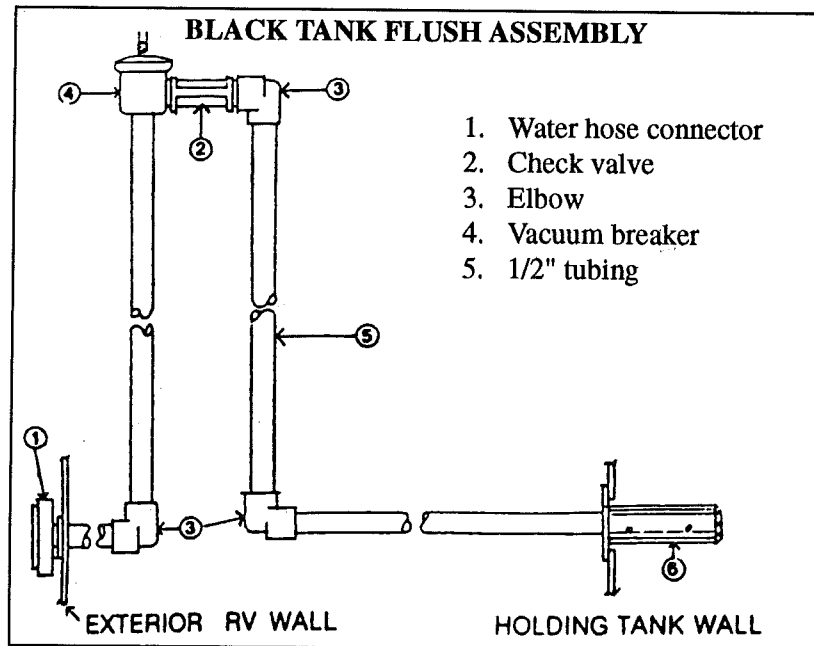

When Parked and Connected to Sewer Outlet

When you are in a park and connected to a sewer outlet, keep the main holding tank dump valve closed, and empty the tank every few days or whenever it becomes almost full. **ONLY BY SENDING A LARGE VOLUME OF LIQUID THROUGH THE MAIN HOLDING TANK AT A TIME WILL TOILET PAPER AND OTHER SOLIDS COMPLETELY WASH AWAY.**

This practice will avoid the accumulation of solids in the main holding tank, which could lead to an unpleasant cleaning job. Should solids accumulate, close the dump valve, fill the tank about half full with water, then drive the motorhome for a few miles. The turbulence and surging of the water will usually dissolve the solids into suspension so the tank can be drained. Keep the auxiliary tank valve open when connected to a sewer outlet.

Draining the tanks as described will protect them from freezing during storage. When traveling in sub-freezing temperatures, use a winterizing solution designed for RV use. Follow the directions on the container.

CAUTION: Never put wet strength paper towels or tissues in your holding tank, since they won't dissolve and can "catch" in the mechanism of the dump valve. Colored toilet tissue is slower to dissolve than white. Most RV accessory stores offer tissue, designed for RVs, that will completely dissolve.

Drain Systems Cleaning

There are many deodorizers on the market in tablet, liquid, and powder form. These not only combat odor, but stimulate the bacteria that works to dissolve the solids in your tank. Picking a deodorizer with lubricating qualities will ease slide valve operation.

The only cleaning agents that can be used without causing harm to the system are household ammonia and trisodium phosphate in small quantities. Do not use any product that contains any portion of petroleum distillates. This attacks the rubber seals of your toilet and dump valve. Also, do not use any dish detergent or abrasive cleaners. All products should be marked approved for ABS drainage systems.

When winterizing drains use only recreational vehicle plumbing type antifreeze. These are sold through your dealer.

TOILET

Manufacturer: Thetford Corporation
7101 Jackson Road
Ann Arbor, MI 48103
313-769-6000

The RV toilet in your Airstream is a design that has been used for many years. There are two pedals. The large pedal opens and closes the slide mechanism, and the smaller pedal opens and closes a water valve.

In normal use, when you are hooked up to city water, both pedals are depressed together. This dumps the sewage and fresh water and flushes down the side of the bowl. Water will continue to run into the bowl for a short time after the pedals are released.

When you wish to conserve water, hold the handspray head over the bowl and hold down the thumb-operated lever. Now, when you depress the pedal, all the water is routed through the handspray.

CAUTION: When you dump the bowl of the toilet, make sure all paper and solids have cleared the slide mechanism before you allow it to close. Failure to do so can cause the groove for the slide to become jammed, and the slide will no longer close completely.

If the problem should occur, a small nail or bent clothes hanger can be used to "pick" the material out of the groove.

TROUBLE SHOOTING

PROBLEM: Water keeps running into bowl.

CAUSE: The blade in the bottom of the bowl is not closing completely, which in turn keeps the water control valve partially open. The groove into which the blade seats when completely closed is clogged with foreign material.

REMEDY: Insert the end of a coat hanger or similar object into the sealing groove and remove the foreign material. Avoid damaging the rubber seal while cleaning.

PROBLEM: Toilet leaks. There is water on the floor. Specify the problem. Determine if water is leaking from:

CAUSE:

- a. Vacuum breaker.
- b. The water-control valve.
- c. Bowl to mechanism seal. (If this is the problem, the water would not stay in the bowl.)
- d. Closet flange base seal.

REMEDY:

- a. The vacuum breaker. If the vacuum breaker leaks when flushing the toilet, replace vacuum breaker.
- b. If the vacuum breaker leaks when the toilet is not in operation, replace the water control valve.
- c. Leaks at the bowl to mechanism seal. Remove mechanism and replace seal.
- d. Leaks at closet flange area. Check front and rear closet flange nuts for tightness. If leak continues remove the toilet, check the closet flange height. The height should be between 1/4" and 7/16" above the floor. Adjust closet flange height accordingly and replace closet flange seal.

PROBLEM: Foot pedal operates harder than normal or the blade sticks.

REMEDY:

- a. Apply a light film of Silicone spray to blade.
- b. Check closet bolt tightness. If closet bolts are over tightened, the mechanism may be distorted.

PROBLEM: Bowl will not hold water; i.e., water leaks from bowl down into the holding tank.

REMEDY: Using a bent screwdriver or similar object, scrape the groove in front of the mechanism blade. Generally paper or other foreign material is lodged in this groove, causing the leak.

CAUTION: *Use care not to damage the blade seal. Always make certain that the tool is under the lip of the seal, not above it.*

The tool can easily be made by bending a coat hanger or screwdriver over about 7/8".

MAINTENANCE

If the bowl sealing blade does not operate freely after extended use, it may be restored to its original, smooth operating condition by applying a light film of silicone spray to the blade. To clean the toilet use Thetford Aqua Bowl or any other high grade, non- abrasive cleaner. Do not use highly concentrated or high acid content household cleaners. They may damage the rubber seals.

REMOVAL

1. Shut off water valve behind toilet or main water supply.
2. Disconnect water supply line from toilet. You will probably find a small mirror very useful.
3. Depress pedal and remove nut located in pedal recess.
4. Reach behind toilet and remove nut on opposite side of base from pedals. In some situations you may want to remove the plug in top of the seat designed to give access from above to this nut.

NOTE: Always replace flange seal when toilet has been removed.

VACUUM BREAKER ASSEMBLY AND DISASSEMBLE

Remove vacuum breaker from toilet. Remove 10 screws holding the cover to the housing. This exposes the vacuum breaker float, float seal, and cover seal. The float is free in its chamber and is easily lifted or dumped out.

NOTE: When reassembling the unit, make sure the housing is free of dirt and the raised collar that the float sits on is clean and free of burrs.

When the cover is reinstalled, it is important that the screws be turned backwards until they jump, so that when they are tightened they are in the original thread.

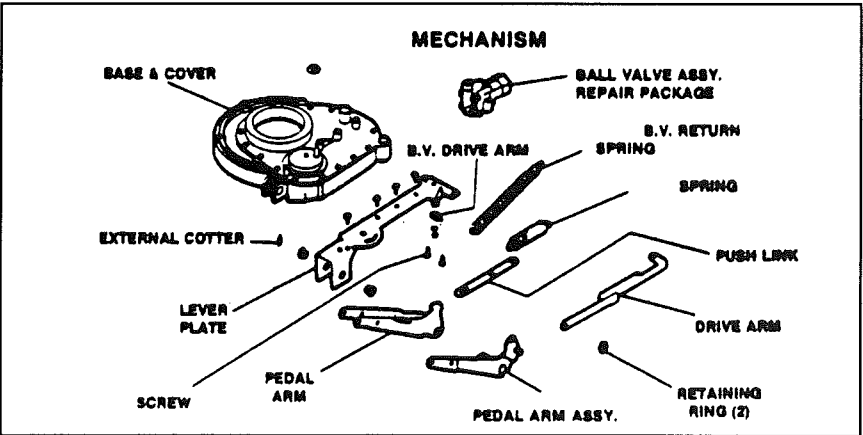
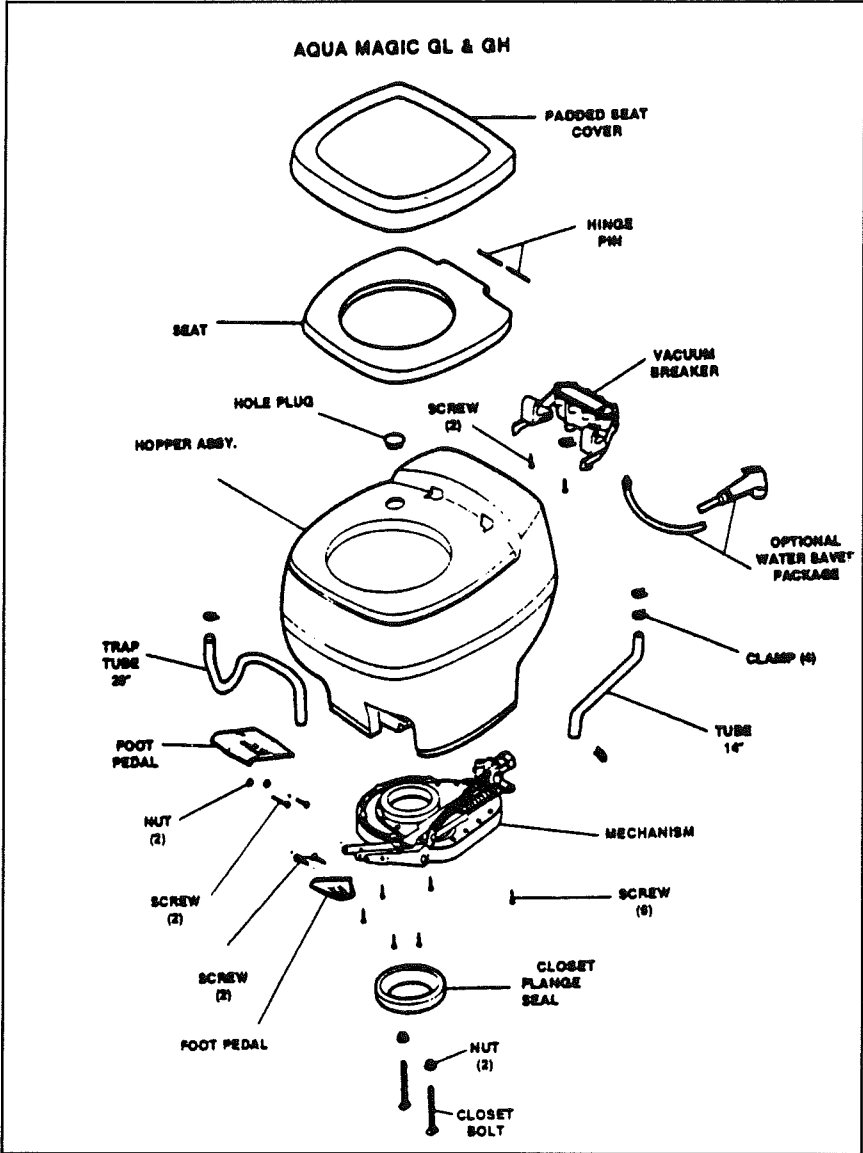

DRAIN LINE, ABOVE FLOOR

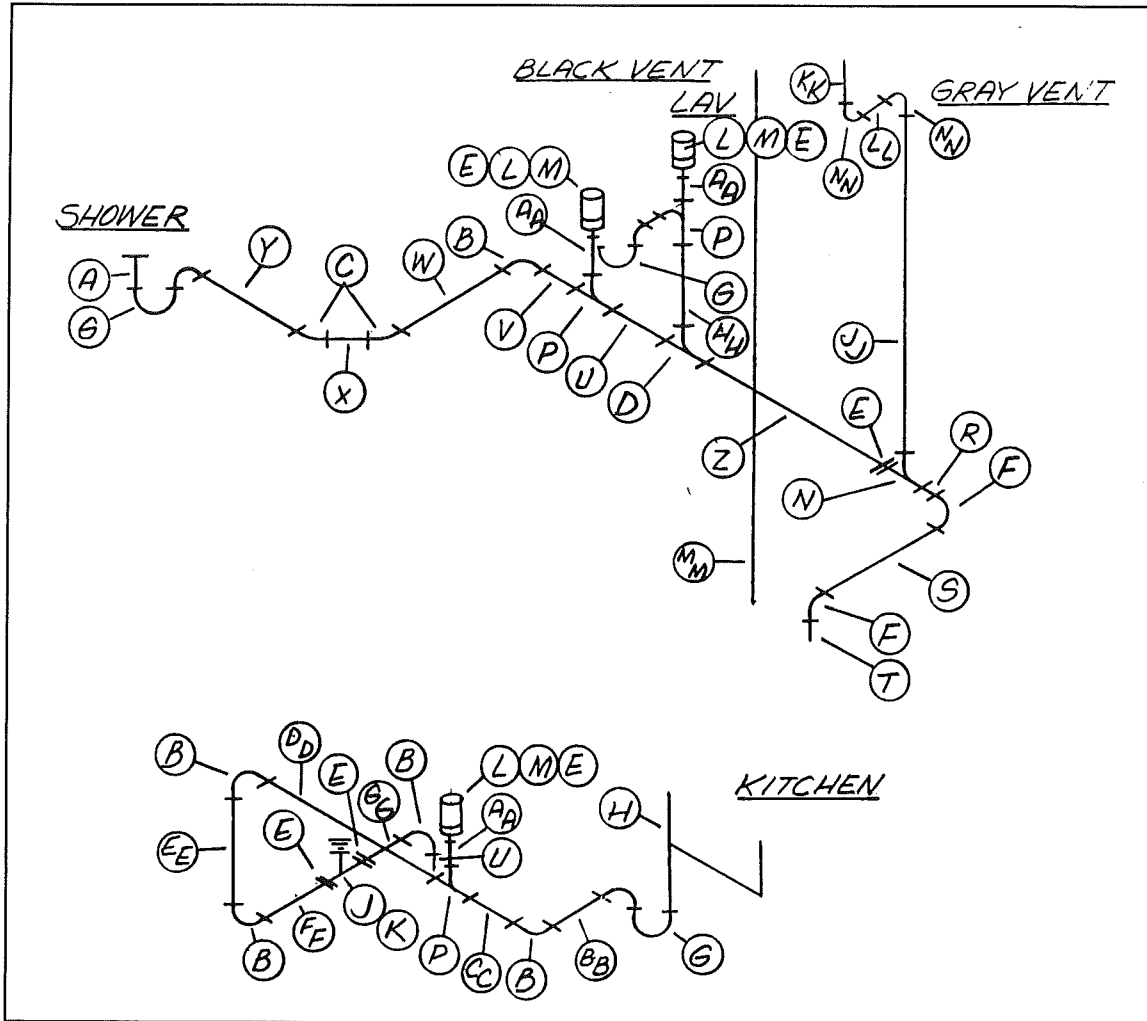

A	601201	Swivel Strainer	V	601160-01	1 1/4 Dia. x 5 1/4
B	601199	1 1/4, 90° XLT Ell	W	601160-01	1 1/4 Dia. x 18 1/2
C	601268	1 1/4, 45° Ell	X	601160-01	1 1/4 Dia. x 1 1/4
D	601305	1 1/4 WYE	Y	601160-01	1 1/4 Dia. x 13
E	601263	1 1/2 x 1 1/4 Reducer	Z	601160-01	1 1/4 Dia. x 24 1/2
F	600035	1 1/2, 90° XLT Ell	AA	601160-01	1 1/4 Dia. x 3 1/2
G	601202	1 1/4 H x HP-Trap	BB	601160-01	1 1/4 Dia. x 6
H	600378	Cont. Waste	CC	601160-01	1 1/4 Dia. x 11 1/2
J	601138	Clean Out Tee (Bi-Dir)	DD	601160-01	1 1/4 Dia. x 27 3/4
K	600155	Clean Out Plug	EE	601160-01	1 1/4 Dia. x 11 3/4
L	600538	Autovent	FF	601160-01	1 1/4 Dia. x 8 1/2
M	601308	Vent Adapt.	GG	601160-01	1 1/4 Dia. x 5 3/8
N	600156	1 1/2 San. Tee	HH	601160-01	1 1/4 Dia. x 16 1/2
P	601198	1 1/4 San. Tee	JJ	601160-02	1 1/2 Dia. x 68
R	601160-02	1 1/2 Dia. x 1 3/4	KK	601160-02	1 1/2 Dia. x 8
S	601160-02	1 1/2 Dia. x 25 1/2	LL	601160-02	1 1/2 Dia. x 4
T	601160-02	1 1/2 Dia. x 3	MM	601160-02	1 1/2 Dia. x 84
U	601160-01	1 1/4 Dia. x 3	NN	600033	1 1/2, 90° Vent Ell

DRAIN LINE, BELOW FLOOR

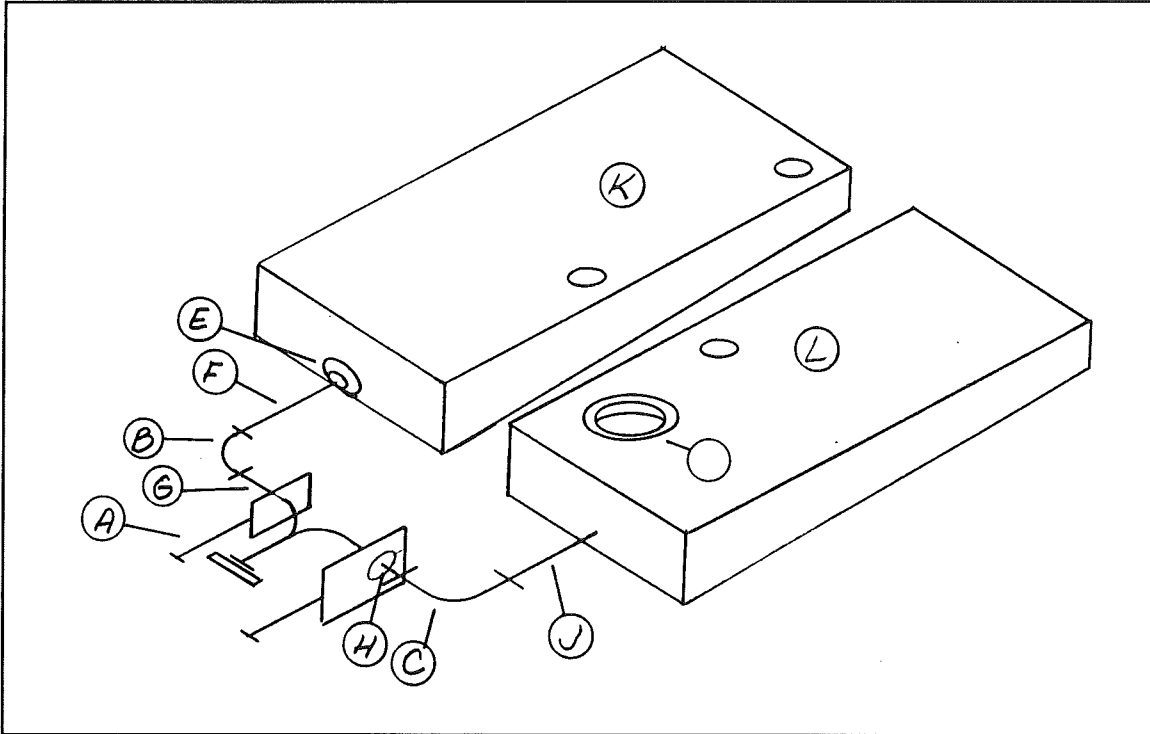

A	601482	1 1/2 x 3 Gate Valve Ass.
B	600035	1 1/2, 90° XLT Ell
C	600183	e", 90° XLT Ell
D	600065	4 x 3" Closet Flange
E	195329-229	3' to 1 1/2" Reducer
F	601160-02	1 1/2 Dia. x 5 1/2
G	601160-02	1 1/2 Dia. x 13
H	601160-04	3" Dia. x 3
J	601160-04	3" Dia. x 6
K	601479	Gray Tank
L	601480	Black Tank

Termination Valve Assembly

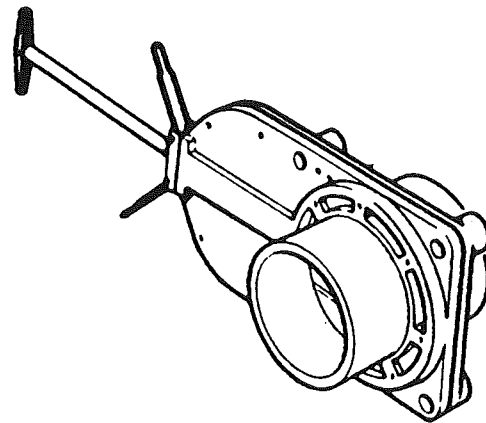

GATE VALVE REMOVAL AND REPLACEMENT

1. Make sure both tanks are empty.
2. Drill out rivet attaching extension handle on some valves.
3. Loosen hose clamp on caulder coupling (see illustration).
4. Remove 4 bolts attaching valve to tank adapter.
5. Twist 3 inch fittings to free from caulder coupling and remove complete assembly.
- *6. Using hacksaw blade, cut valve off next to black drain pipe.
7. Remove the sawed off piece of valve from black pipe by driving a screwdriver into the glued joint about six places. Next drive the screwdriver in about 1/2" deep in six new places. Continue until white piece of cut off gate valve pops free from plumbing.
8. New valve may now be glued in place making sure its position allows the mounting bolts to line up with the tank adapter.

***Note:** If the valve is being rebuilt instead of replaced, there's no need to saw it off. Simply rebuild the valve while it's still attached to plumbing line.

NOTES

ELECTRICAL SYSTEM

12 VOLT SYSTEM

BATTERIES

Your Airstream Land Yacht motorhome is equipped with three batteries: two engine batteries and two coach batteries.

Engine Battery

The engine batteries are used for starting the engine and operating the headlights, tail-lights, running lights, instrument panel lighting, automotive air conditioning and other accessories. The engine battery is charged by the alternator while driving and are located in the rear of the coach. They are part of the Spartan Chassis.

Coach Batteries

The coach batteries are used for interior lighting, exhaust fans, generator, water pump, central control panel, entertainment center, optional 12-volt convenience outlets, and the refrigerator when it is switched to 12-volt power. These batteries are charged by the engine's alternator when driving, or by the converter when plugged into 120 volt city power. They are also charged by the generator, when it is running, through the 120 volt city power system.

Interior Lights

Many interior lights have been included in your motorhome to give you almost infinite variable light intensity.

Just inside the main door on the galley end panel are switches for the step, patio light and forward ceiling lights. The forward ceiling lights must have their switches on before the remote switch on the galley end panel will control them.

In the bathroom the water heater switch supplies power to the ignitor and gas valve. When turned on, it will flash red until flame is sensed, then the red light will be extinguished.

The bulbs in the interior lights are all easily replaced if they burn out. Round, exposed bulbs, such as those around the bathroom mirror and reading lights, are replaced by depressing them into their base, then turning to the left about 1/4 turn. This will allow them to "pop" out part way, so they can be removed.

WARNING: If they are difficult to turn, use a folded rag to protect your hand when grasping the bulb in case it should unexpectedly shatter.

The ceiling and wardrobe light lenses are removed by squeezing the sides of the lens in until they clear the frame. In cold weather it is helpful to leave the light on for a while to soften the plastic and avoid cracking. Incandescent bulbs are removed by depressing and turning to the left about 1/4 turn. Fluorescent bulbs are removed by turning in either direction.

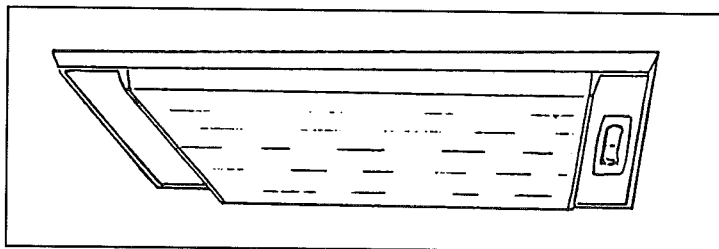

12 Volt Operation

The coach batteries are located in the front engine access compartment. When you raise the hood, you'll see the batteries with the "knife" switches.

The only thing you have to do is make sure the two auxiliary batteries don't run down. In normal usage there isn't any problem, since you would normally drive part of the day and be plugged into a camp ground at night. The alternator charges the batteries when you drive and when you're plugged into city power the converter charges the batteries and carries much of the load.

Some nights you may not find a place to plug into city power. No problem; the batteries total about 210 amp-hours, so you can comfortably run your lights and vents in a normal fashion without depleting the batteries.

If you are not plugged into city power and you're not driving, you'll want to conserve your batteries by using as few lights and appliances as possible. If you notice the lights becoming dim, it's much easier on the batteries if you go ahead and start the engine or generator before the batteries run down.

There are two sets of 12 volt fuses and breakers in your motorhome. The main interior circuits are in the 12-volt distribution panel on the curbside of the front center console. The brightly colored fuses pull straight out from the face of the panel. Replacement fuses are available at automotive stores and most service stations. On the panel covering the fuses is a diagram showing the function of each fuse or circuit breaker.

The second set of Spartan breakers are located under the front hood. The function of most of the breakers is marked directly on the face of the fuse block. See your Spartan Drivers Manual for further information. An illustration in the following diagram section of this book shows the placement and function of wires added by Airstream.

Basic 12V Wiring

On the following fold out sheet is a drawing of the 12-V wiring used in the Land Yacht motorhome.

The knife switches at the batteries are intended to be used for long term storage. If you're not going to use your motorhome for a week or two, just leave the switch closed. If it's going to be more than a couple of weeks before using your coach, open the switch. This will assure your batteries will remain in the best condition possible. For long-term or winter storage, the batteries should be removed from the vehicle and stored where they can be recharged about every thirty days.

On the following pages are 12-volt wiring diagrams. The first drawing simply labeled "12V Wiring" will probably be the most useful. It shows how the power from the batteries reaches the main components.

The batteries, power distribution block, *50 amp breaker, auxiliary start solenoid, and isolator are all located under the front hood.

The converter is located behind the kick panel in front of the passenger cab seat. The 12-volt distribution panel is located on the curbside of the front center console.

*In years past, most 12-volt circuit breakers were automatic – if they kicked out after a brief period of time they would reset themselves. Recently the automatic breakers have all been replaced with the type that must be manually reset. The reset button is in the end of the breaker and is depressed to reset. The button is small and in many cases directly under a wire so they can be difficult to see.

12V WIRING DIAGRAMS

- 12 volt wiring main
- 12 volt calculations
- 12 volt fuse panel, Airstream
- Harness, body interior
- Harness, ceiling
- Harness, body, chassis
- Harness, firewall
- Harness, A pillar
- Harness, body, upper
- Harness, wiper/washer
- Harness,dash switches
- Harness, dash lights
- Harness, head lights
- Harness, clearance lights rear
- Harness, tail lights
- Harness, drivers door
- Harness, mirrors

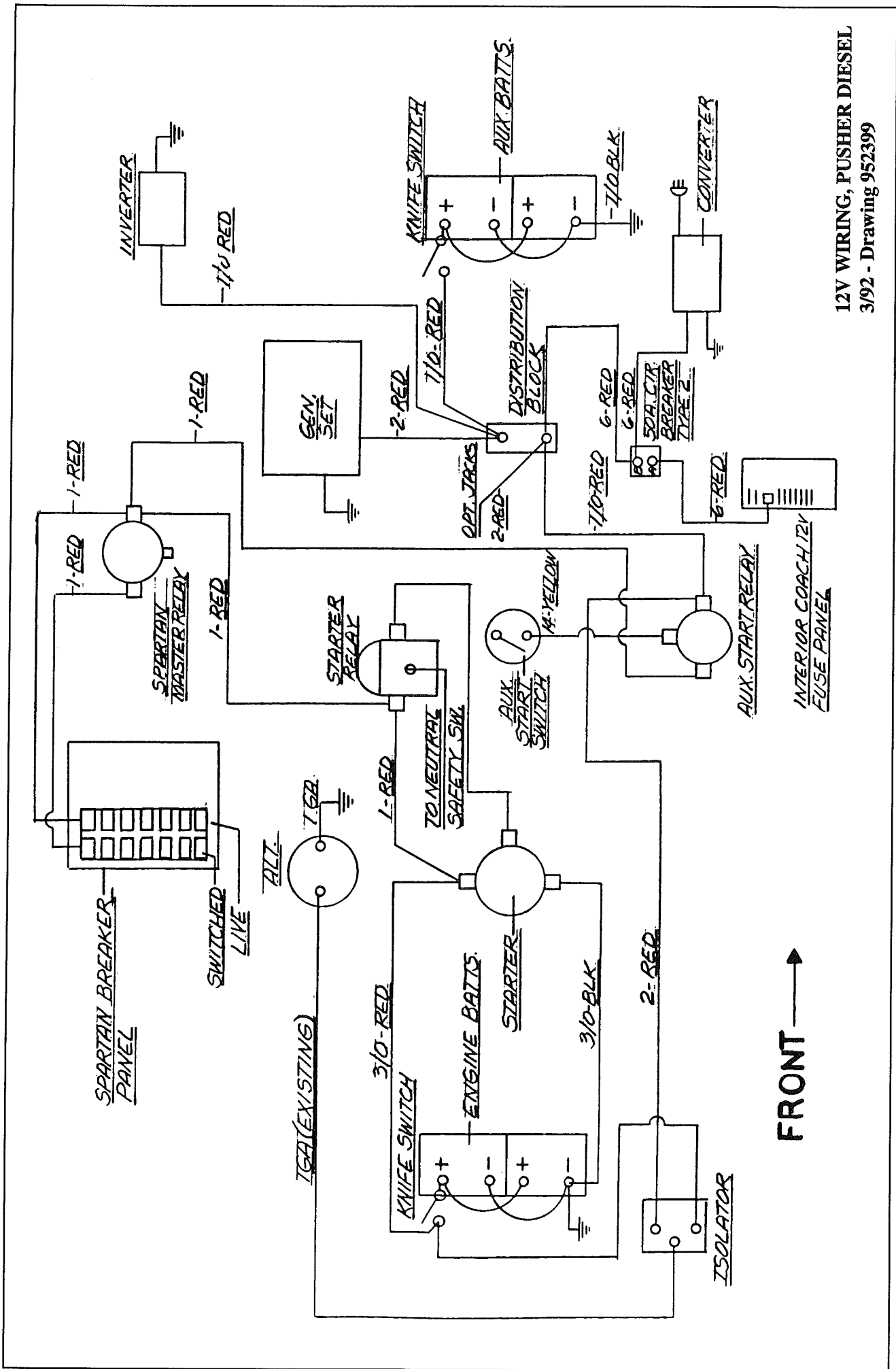

12V WIRING, PUSHER DIESEL
3/92 - Drawing 952399

FRONT →

HARNES, WIPER/WASHER

CONNECTOR SIDE

TO "F" INSERT INTO POSITION "F"

5

MOTOR SIDE

TO RED
TO BLUE
TO BROWN+GREEN
TO BLACK

1
2
3
7

1
2
3
7

TO "E"
TO "D"
TO "C"
TO "B"

TO WASHER MOTOR
FEMALE TERMINALS

6
5

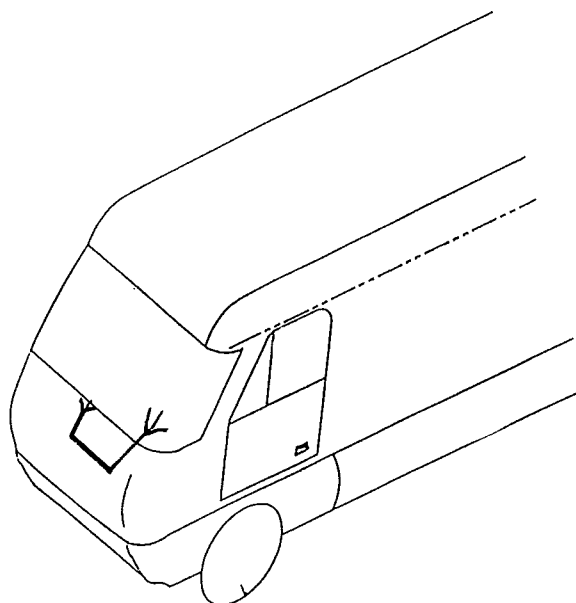

WIRE CHART

Circ.	Ga.	Color
1	14	Red
2	14	Blue
3	14	Green
5	14	Blue/White
6	14	Black
7	12	Black

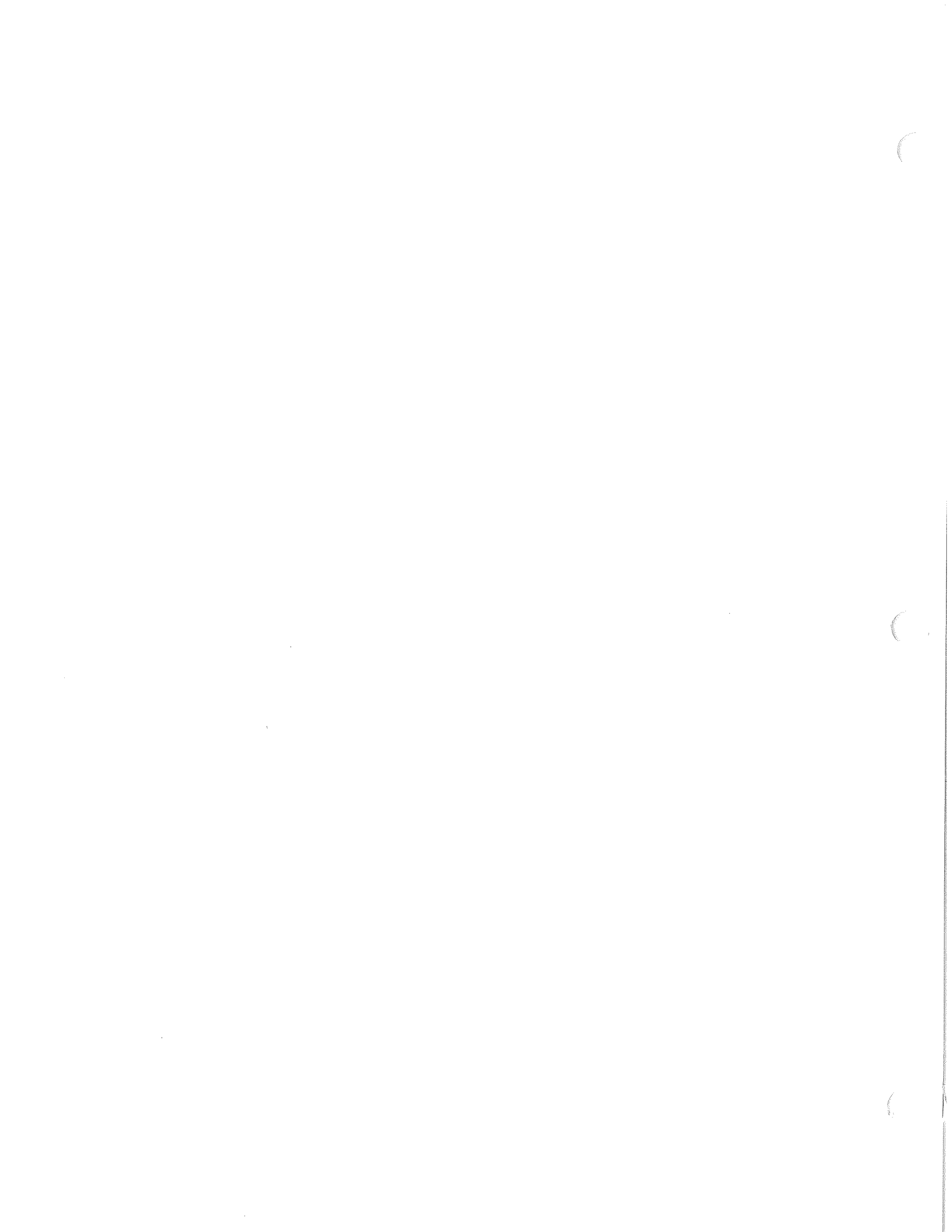

HARNES, DASH SWITCHES

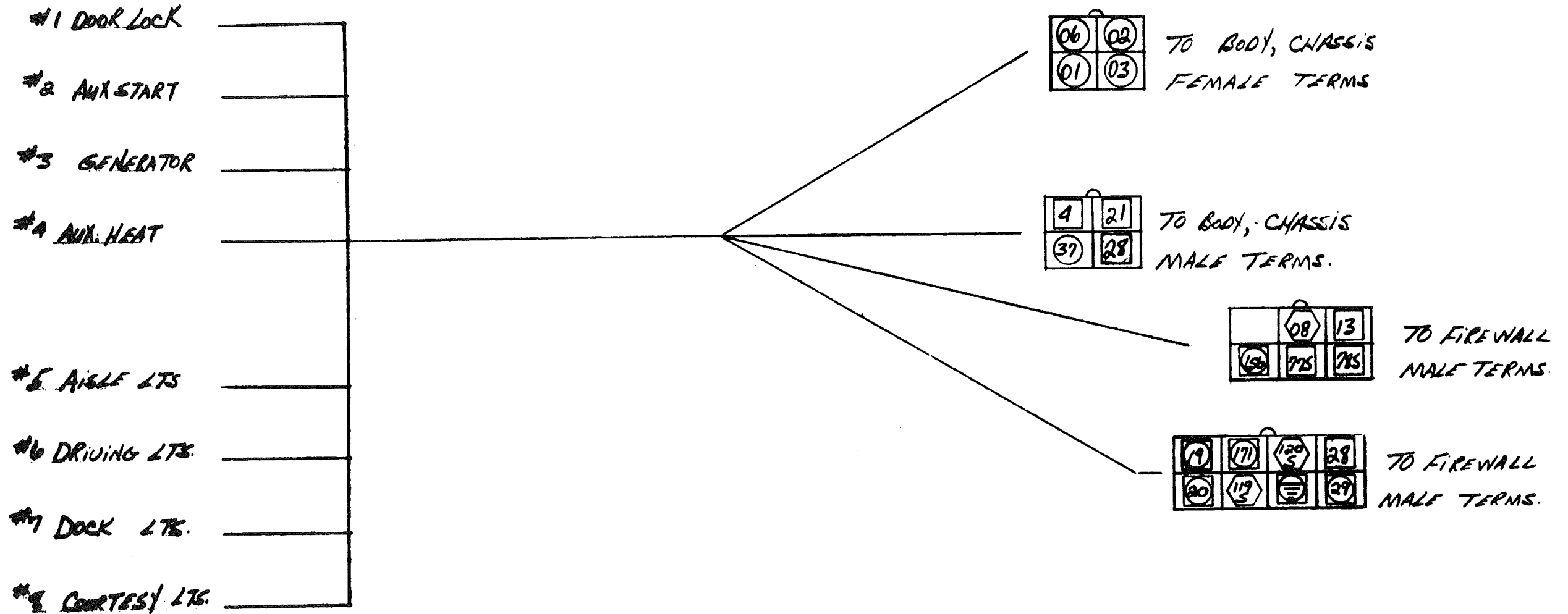

Switch	Pin 2	Pin 4	Pin 6	Lt. Pins 3 & 4	Lt. Pins 5 & 6
#1 Door Lock	171 14 Blk/Wht	119S 16 Yel	120S 16 Pk	37 & 171 18 Blk/Red 14 Blk/Wht	08 & ≡ 16 Gray/Wht
#2 Aux. Start	4 12 Brown	29 14 Yellow			08 & ≡ 16 Gray/Wht
#3 Generator	01 18 Blk	03 18 Yellow	02 18 Brown	06 & ≡ 18 Red/Wht	08 & ≡ 16 Gray/Wht
#4 Aux. Heat	13 12 Blue	78S 12 Org/Wht (Hi)	Pin3 77S 12 Red/Wht (Lo)	16 Gray/Wht	08 & ≡
#5 Aisle Lts.	4 12 Brown	21 12 Green			08 & ≡ 16 Gray/Wht
#6 Drive Lts.	19 14 Brown	20 14 Blue/Wht			08 & ≡ 16 Gray/Wht
#7 Dock Lts.	4 12 Brown	28 12 Purple			08 & ≡ 16 Gray/Wht
#8 Courtesy Lts.	156 14 Grn	≡ 14Wht			08 & ≡ 16 Gray/Wht

Circ.	Ga.	Color	Function
01	18	Black	Gen. (Ground)
02	18	Brown	Gen. (Stop)
03	18	Yellow	Gen. (Start)
06	18	Red	Gen. (Hour meter)
08	16	Gray	I.P. Lts. - Rheo.
4	12	Brown	+12V
19	14	Brown	Tail & Marker Lts.
20	14	Blue/Wht	Drive Lt. Relay
21	12	Green	Aisle Lts.
28	12	Purple	Dock Lts.
29	14	Yellow	Aux. Start Sol.
37	18	Blk/Red	Lock Ind. Lt.
119S	16	Yellow	Door Lock
120S	16	Pink	Door Unlock
156	14	Green	Courtesy Lt. Grnd.
171	14	Blk/Wht.	H2V, Door Lock
13	12	Blue	+12V Aux. Heat
77S	12	Red/Wht	Aux. Heat SW (Lo)
78S	12	Org/Wht	Aux. Heat SW (Hi)

NOTES:
1. All Connectors wire side view

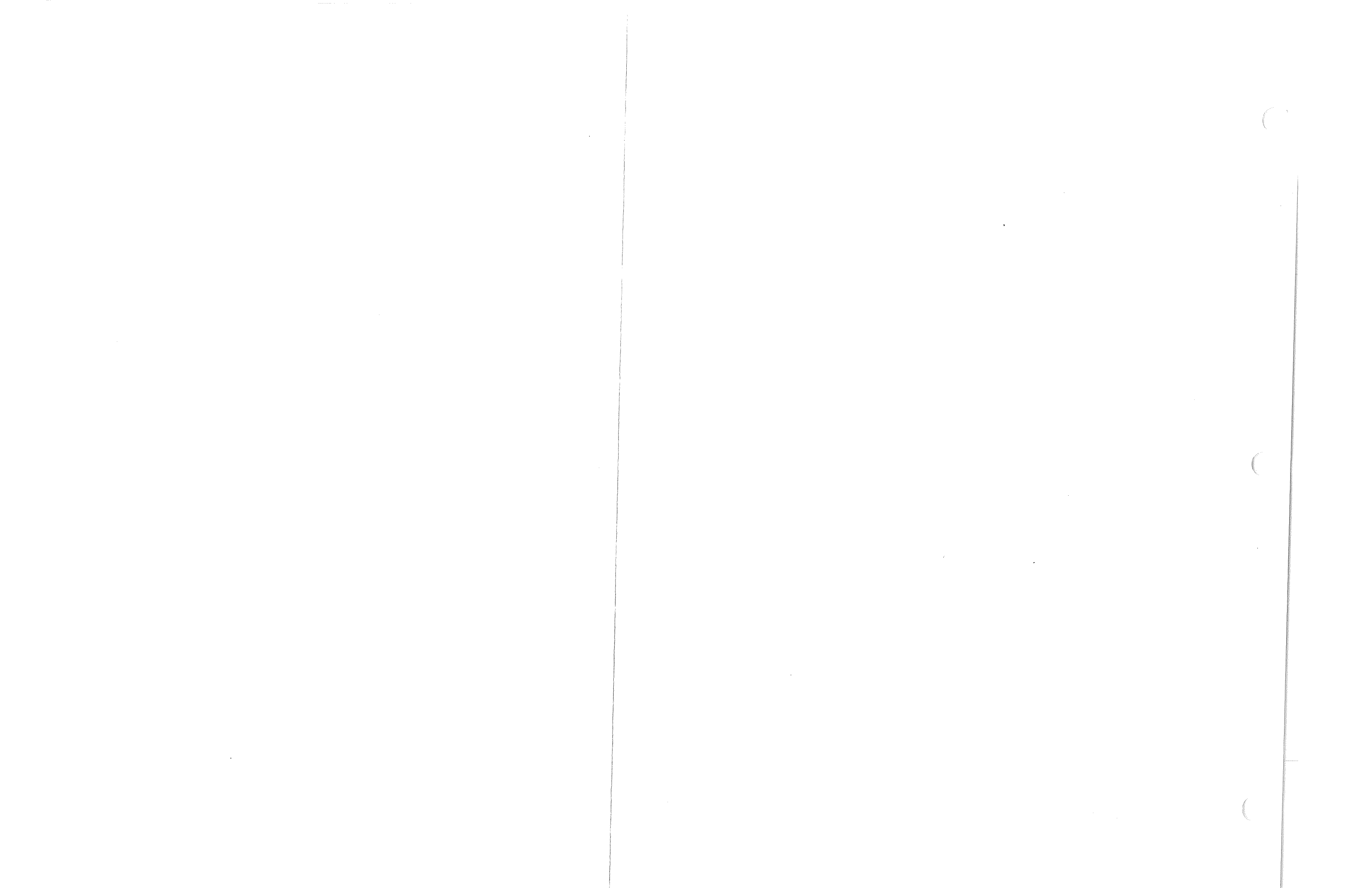

HARNES, DASHLIGHTS

WIRE CHART

Circ.	Ga.	Color	Function
156	16	Green	Dash Lts, Ground
240	16	Orange	Dash Lts, +12
08	16	Gray	Instrument Lts. +12

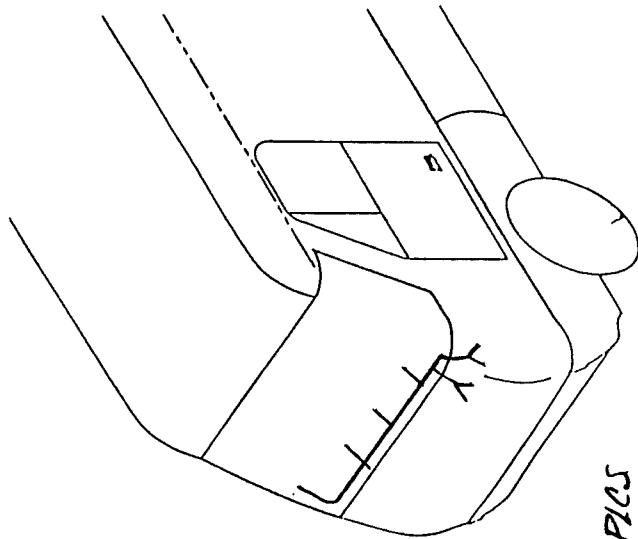

DASH LTS
 56 240 TYP (5) PICS

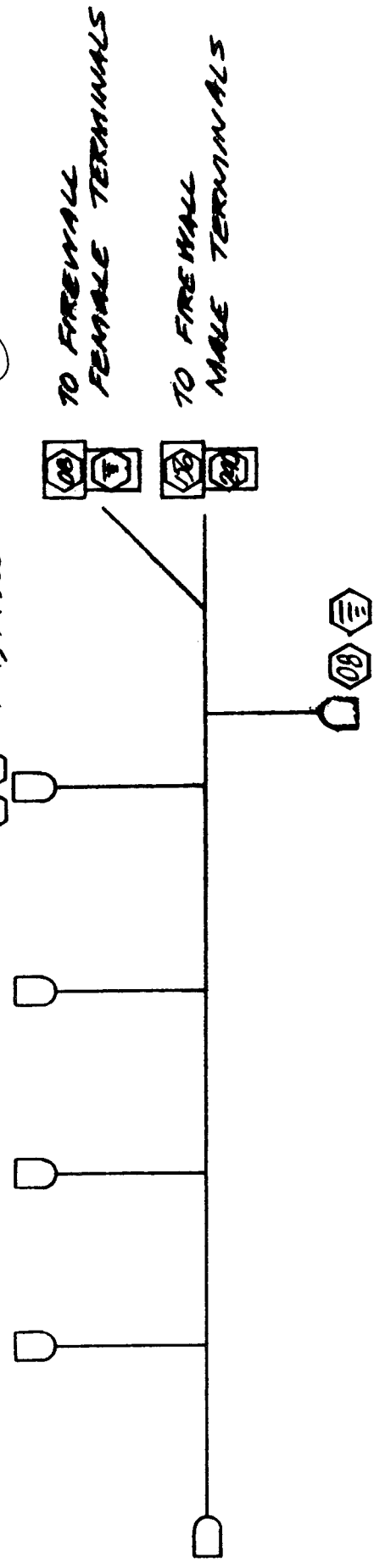

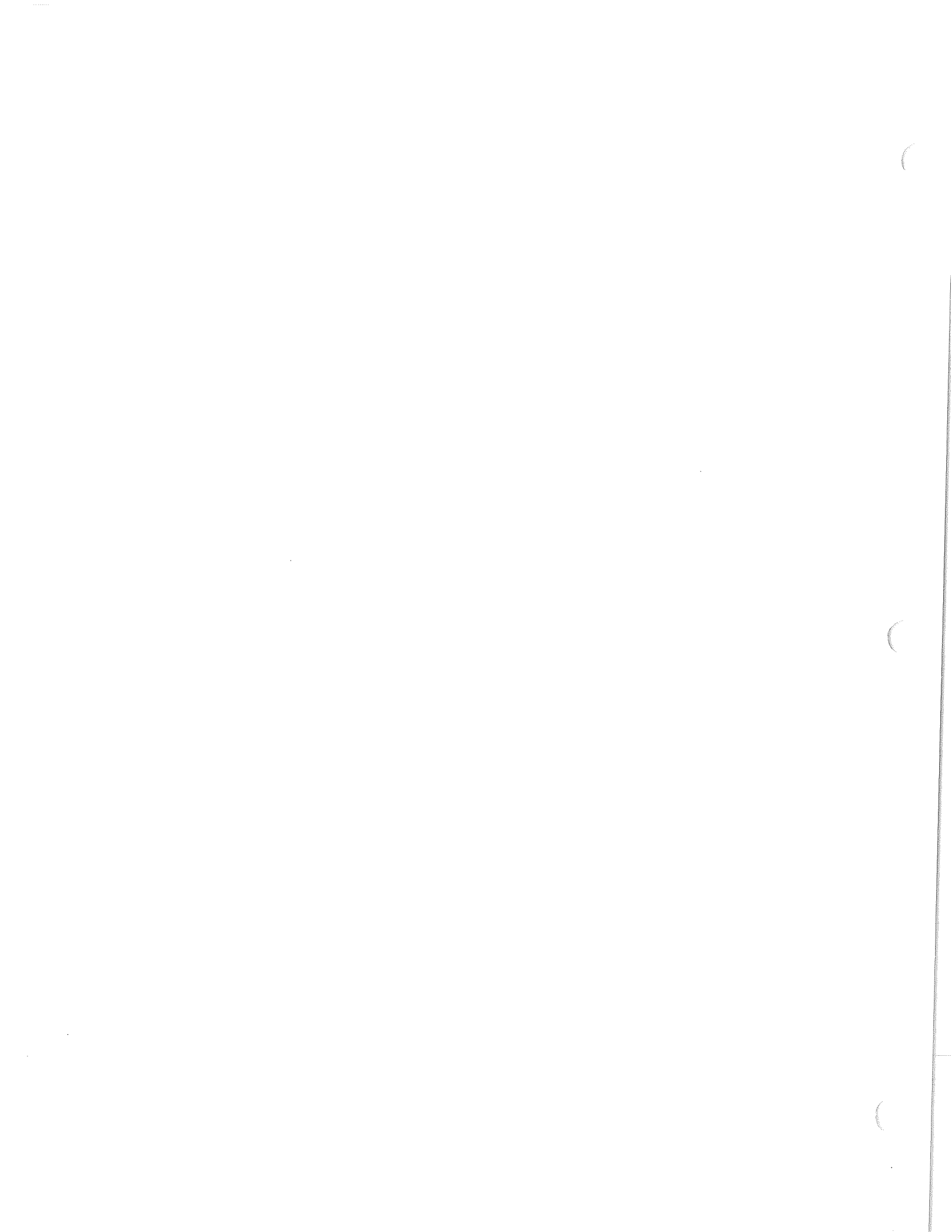

HARNES, HEADLIGHTS

WIRE CHART

Circ.	Ga.	Color	Function
19	14	Brown	Park Lts.
24	14	Lt. Blue	Left Turn
25	14	Dk. Blue	Right Turn
28	12	Purple	Dock Lts.
36	14	Red	Driving Lts.
111	14	Lt. Green	Hi Beam
112	14	Tan	Lo Beam

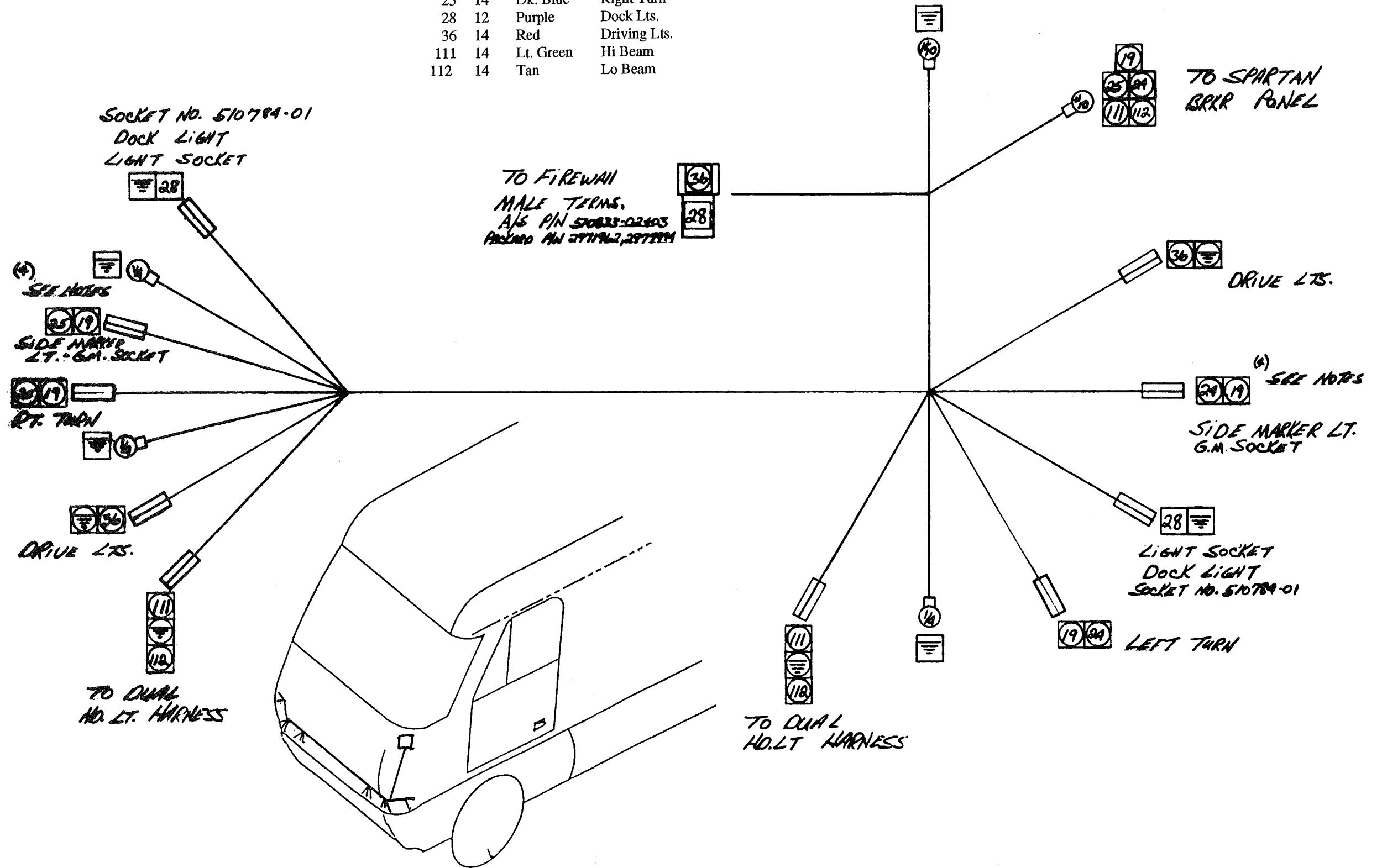

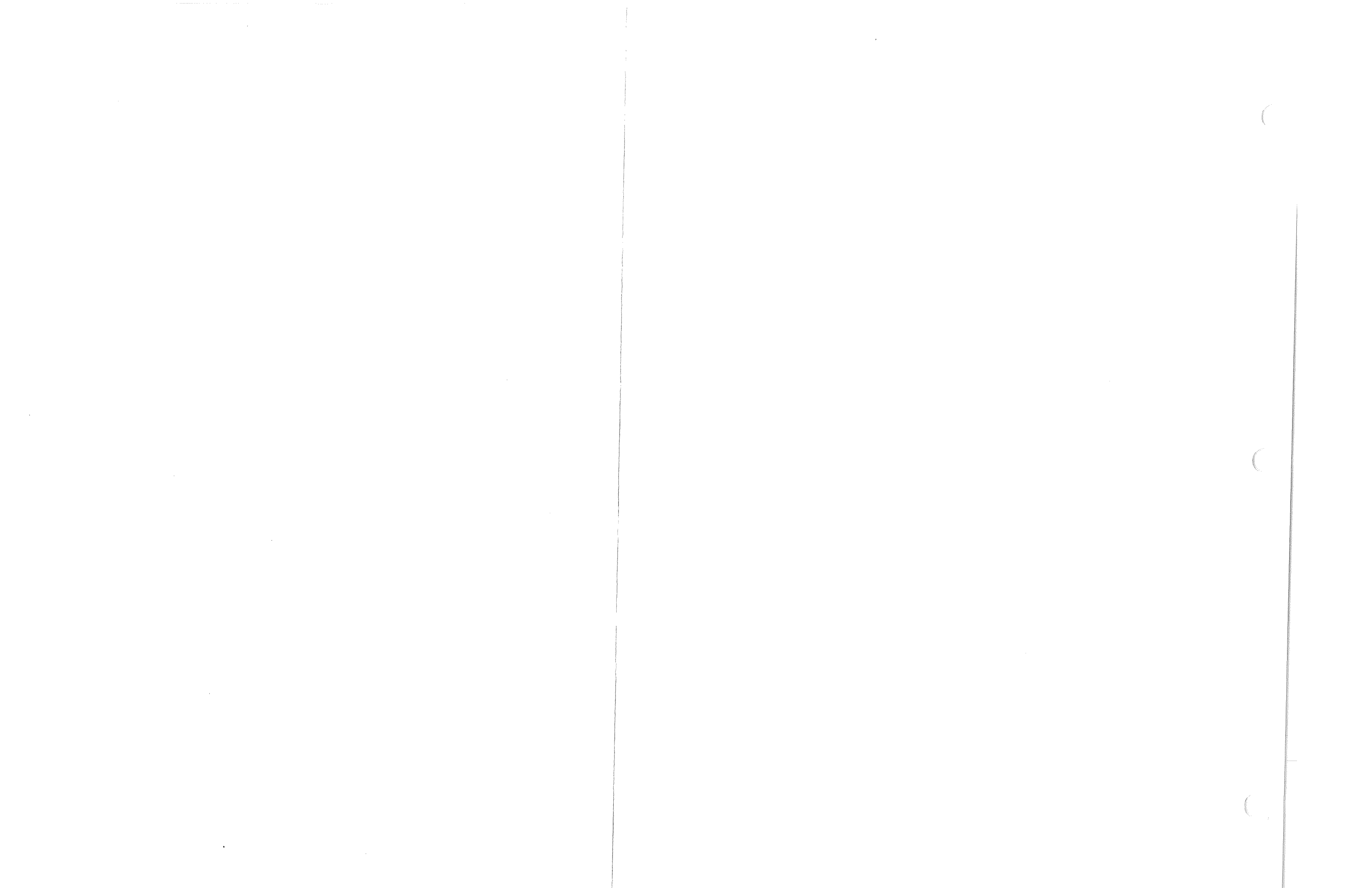

HARNES, CLEARANCE LIGHTS, REAR

WIRE CHART

Circ.	Ga.	Color	Function
19	14	Brown	Clearance Lts.

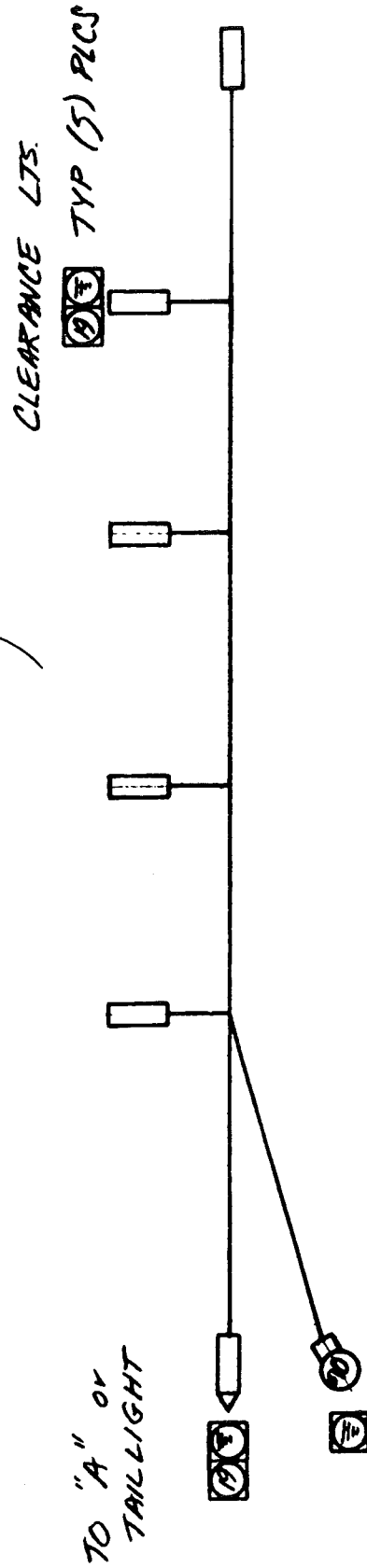
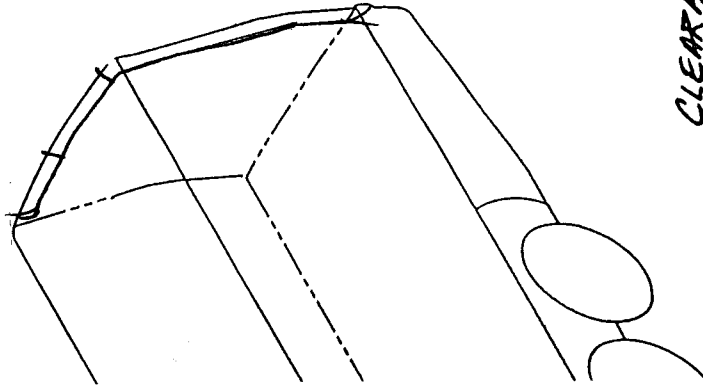

HARNES, TAILLIGHTS

WIRE CHART

Circ.	Ga.	Color	Function
19	16	Brown	Taillights
24	16	Yellow	Left Turn
25	16	Dk. Green	Right Turn
27	16	Lt. Green	Back-up

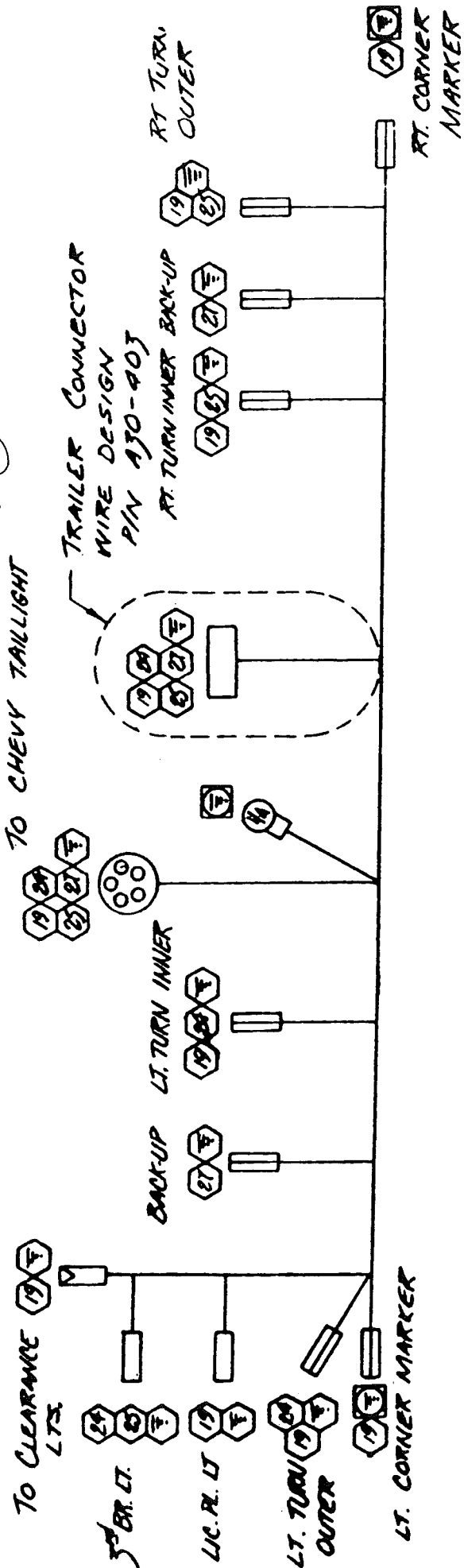
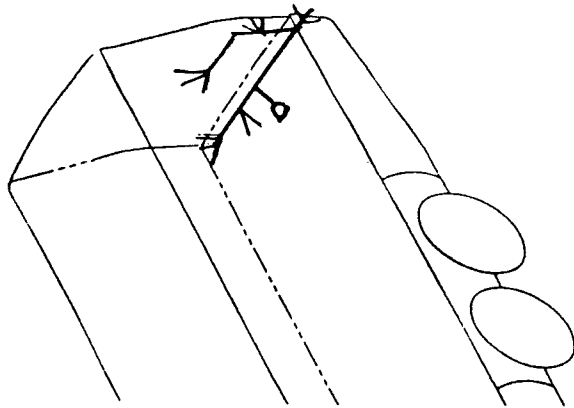

HARNES, DRIVERS DOOR

WIRE CHART

Circ.	Ga.	Color	Function
3	12	Orange	Cig. Lighter
15	12	Red	Pwr. Window
156	16	Green	Dash Lts, Ground
240	16	Orange	Dash Lts, 42

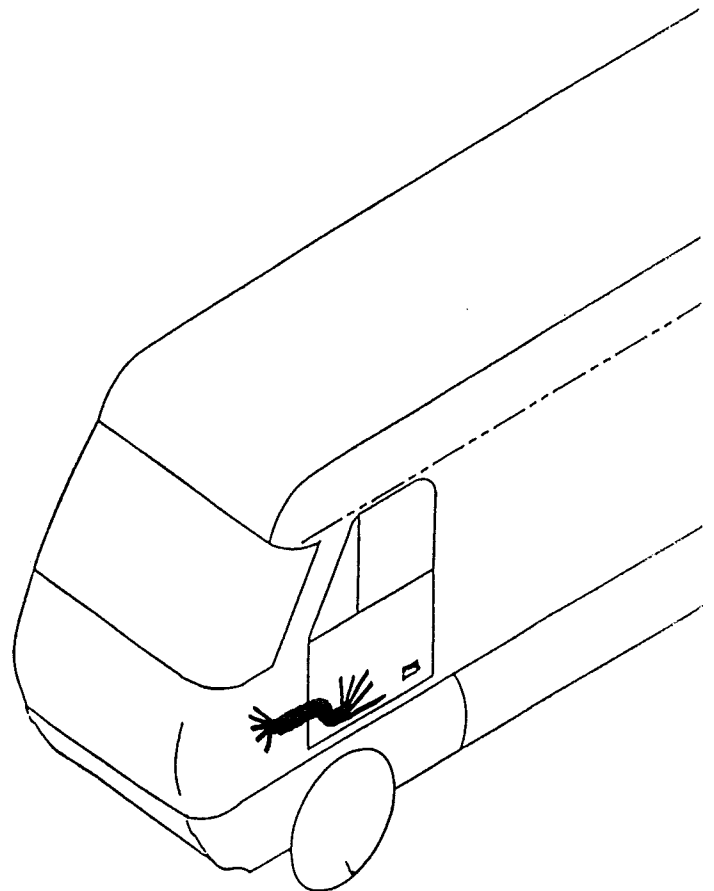
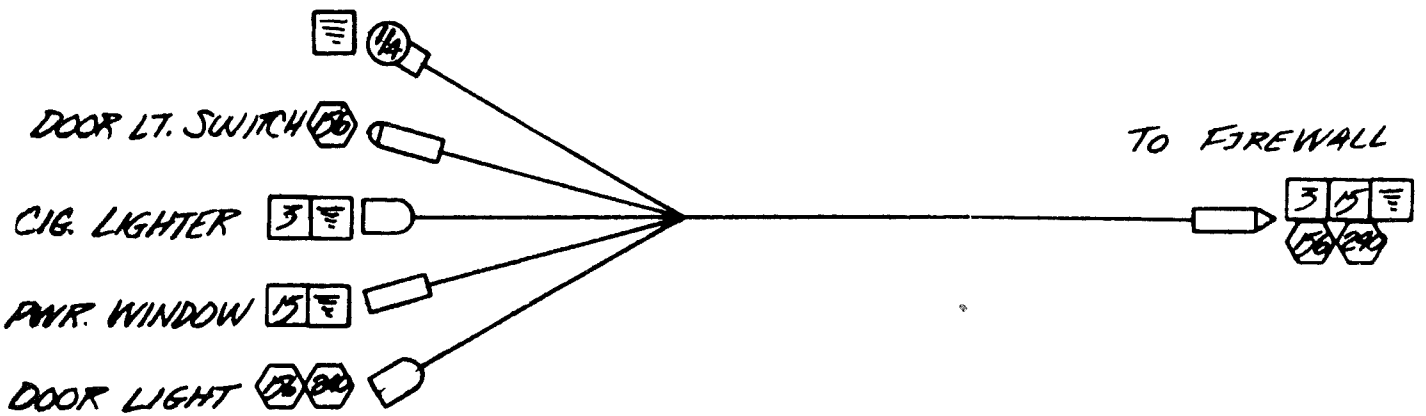

Circuit 1, 20AMPS, Purple

Bedroom Wall Lamps (2) 6.00 Amps.
 Bedroom Reading Lights (2) 2.08
 Bedroom Ceiling Light 2.10
 Wardrobe Light 1.00
 Bedroom T.V. 5.00
Total 16.18 Amps.

Circuit 2, 20 AMPS, Yellow

Electronic Water Heater 1.00 Amps.
 Bath Vent Fan 2.50
 Double P.D. BathLight 2.88
Total 6.38 Amps.

Circuit 3, None

Circuit 4, 20AMPS, Brown

Docking Lights (6) 6.00 Amps.
 Aisle Lights (4) 4.00
 T.V. 7.00
Total 17.00 Amps.

Circuit 5, 20 AMPS, Blue

Double P.D. Dinette Light 2.88 Amps.
 Double P.D. Living Area Light 2.88
 Double P.D. Galley Light 2.88
 Reading Lights (2) 2.08
 Ceiling Vent Fan 2.50
 Cool-O-Matic Vent 5.30
Total 18.52 Amps

Circuit 6, 20 AMPS, Red

Oven Light 1.00 Amp.
 Furnace 5.4
 Compartment Lights 10.0
TOTAL 16.4 Amps

Circuit 7, 20 AMPS, Black

Ceiling Lights (5) 14.40 Amps.
 Porch Light 1.00
 Entry Light 1.00
 Step Light 1.00
Total 17.40 Amps.

Circuit 8, None

Circuit 9, 20 Amps, Green

Pump 7.00 Amps.
 Range Vent W/Light 3.20
Total 10.20 Amps.

Battery Charger 3.0 Amps. (Floating Type)

Total Amps: 105.08

1st. 20 Amps @ 100% = 20 Amps.
 2nd. 20 Amps @ 50% = 10 Amps.
 65.08 Amps @ 25% = 16.27 Amps.

46.27 Amp Converter Required by Calculation

Todd, PC-50, 50 Amp Converter Used

ITEM	PART NUMBER	DESCRIPTION	QTY.
TOLERANCES (except as noted)			
DECIMAL	AIRSTREAM		DIVISION
=	34 S.B.Legacy		Engineering
FRACTIONAL	34 S.B.Legacy		DRAWN BY T.C.
=	TITLE		APPROVED BY
ANGULAR	12V Calculations		
=	NEXT ASSY.	DATE	DRAWING NUMBER
		10/91	952392
			REV.

*All Appliances are
 Installed per Mfgr's
 Instructions Per
 NEC 551-3(e-3)

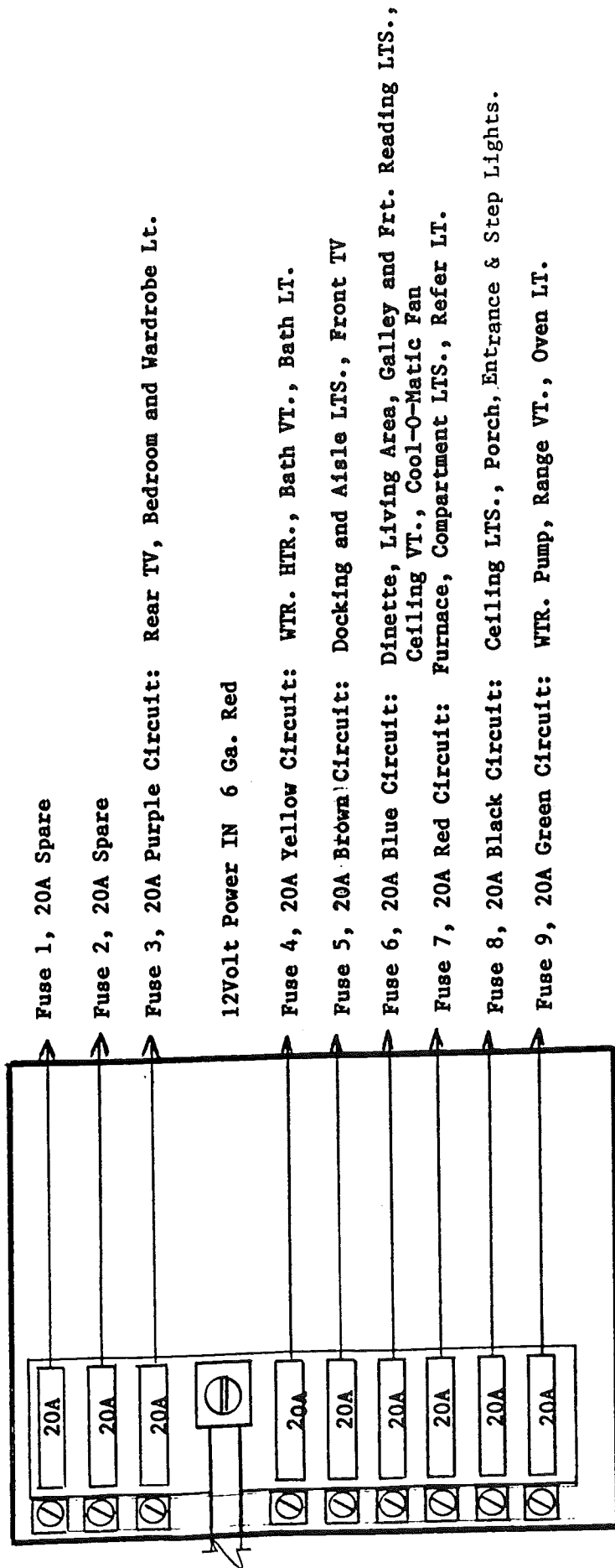

ITEM	PART NUMBER	DESCRIPTION	QTY.
TOLERANCES (except as noted)		AIRSTREAM	DIVISION
			Engineering
DECIMAL	34	PRODUCTION Pusher	SCALE
=	30	& 34 Legacy MH	DRAWN BY T.C.
FRACTIONAL		TITLE	APPROVED BY
=		12 V Fuse Panel	
ANGULAR		NEXT ASSY.	DATE
=		9/91	DRAWING NUMBER
			952389
			REV.

15

16

17

HARNES, BODY INTERIOR

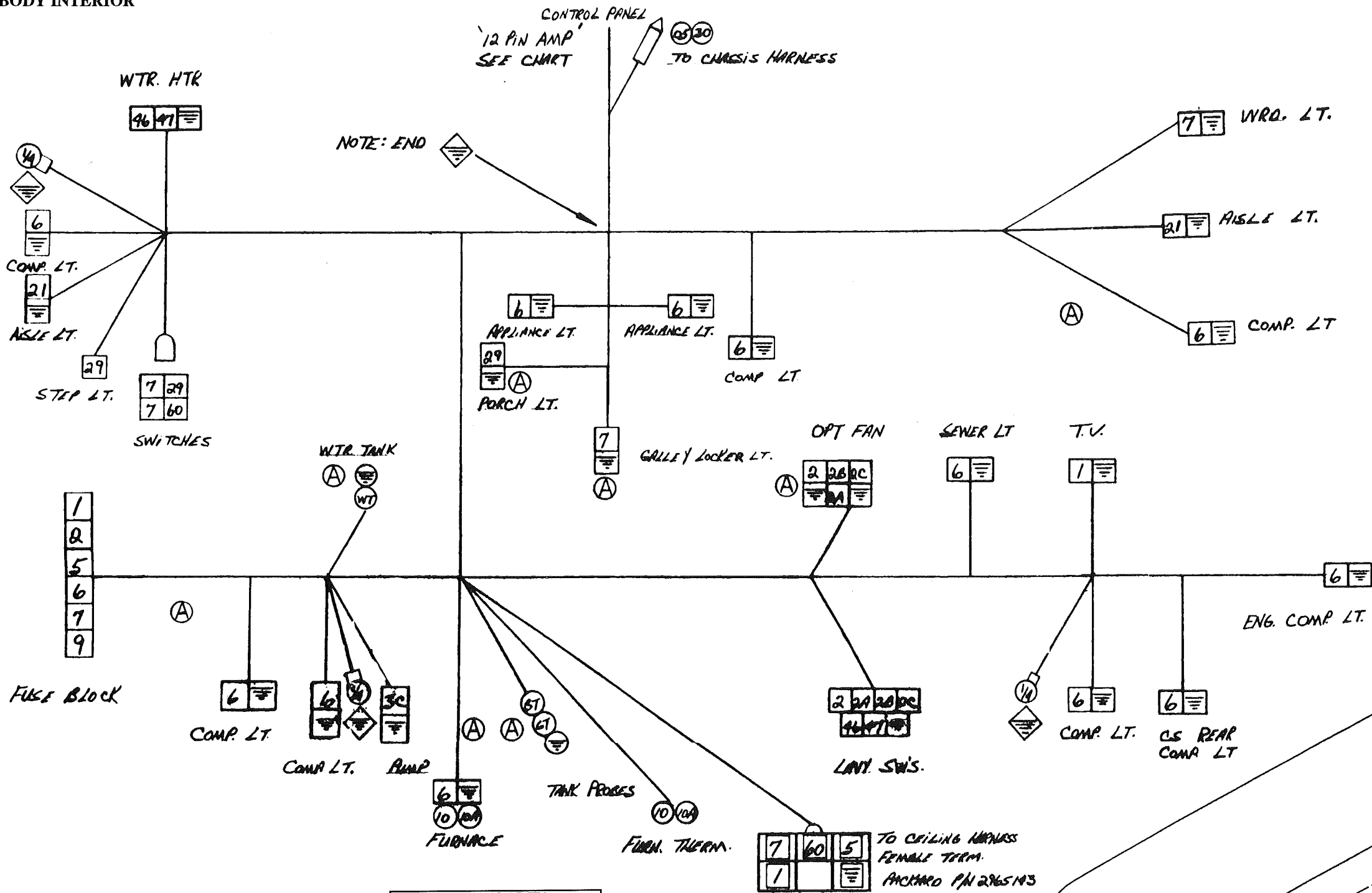

WIRE CHART

Circ	GA	Color	Function
1	12	Purple	+12v, Bd.Rm. Lts.
2	12	Yellow	+12v, Bath Lts.
5	12	Blue	+12v, Locker Lts.
6	12	Red	+12v, Furniture & Comp. Lts.
7	12	Black	+12v, Ceil. Lights
9	12	Green	+12v, Control Panel
2A	12	Blue	Opt. Bath Fan
2B	12	Red	Opt. Bath Fan
2C	12	Black	Opt. Bath Fan
3C	12	Org/Wht	Water Pump
05	18	Orange	Batt. Sense
10	18	Blue/Wht	Furnace Thermostat
10A	18	Blue/Wht	Furnace Thermostat
21	12	Green	Aisle Lts.
29	12	Brn/Wht	Porch Lts.
30	18	Lt. Blue/Wht	LP Level
46	12	Brown	Water Heater
47	12	Lt. Blue	Water Heater
BT	18	Brown	Black Tank
GT	18	Green	Gray Tank
WT	18	Red	Fresh Tank
60	12	Blk/Wht	Ceil. Lts. Sw.

'12 PIN AMP'
HOUSING P/N 770098-1
PIN P/N 350416-1

Pin	Circ	Color
1	9	Green
2	05	Orange
3	3C	Org/Wht
4	30	Blu/Wht
5	9	Green
7	WT	Red
8	GT	Green
9	BT	Brown
11		White
12		White

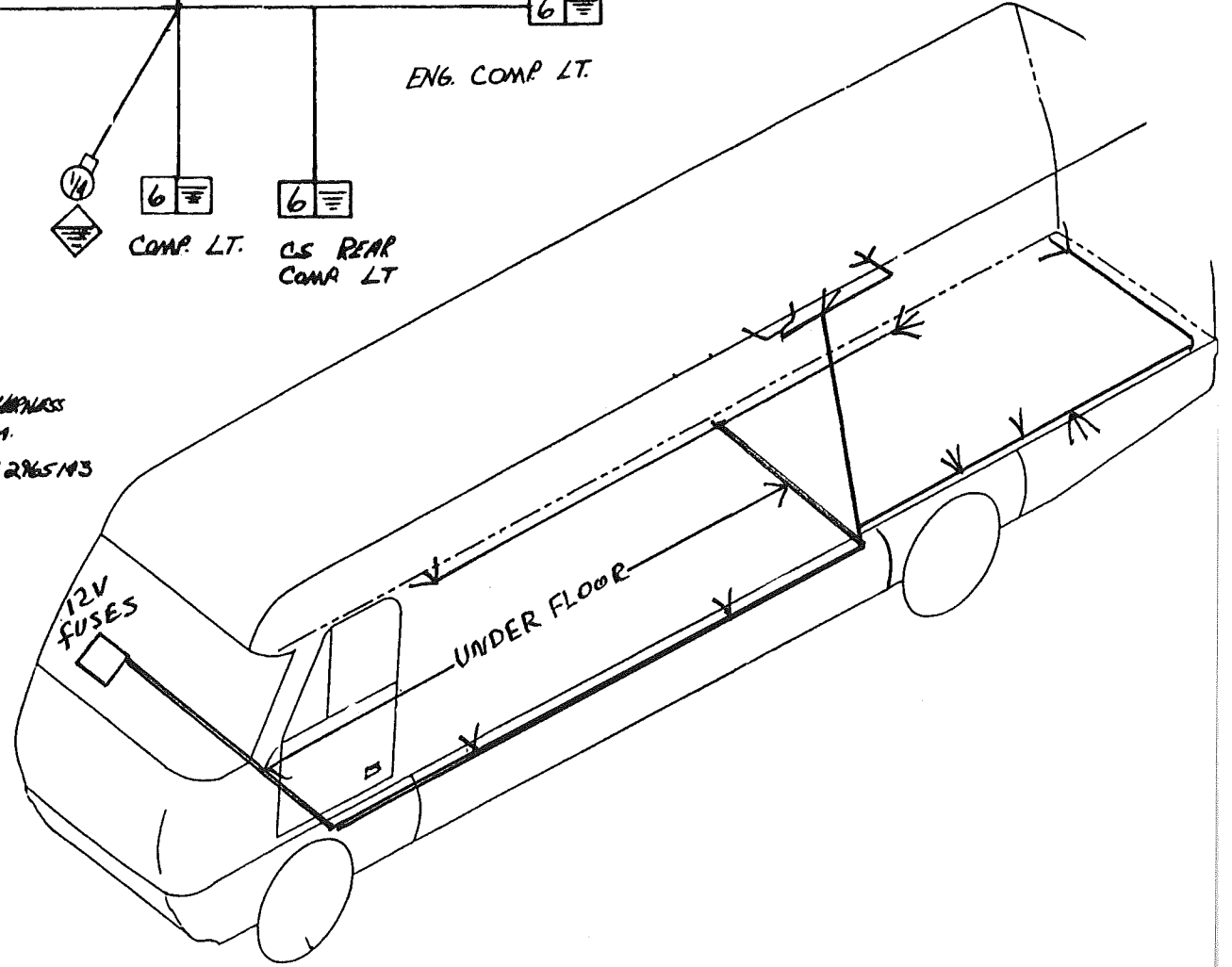

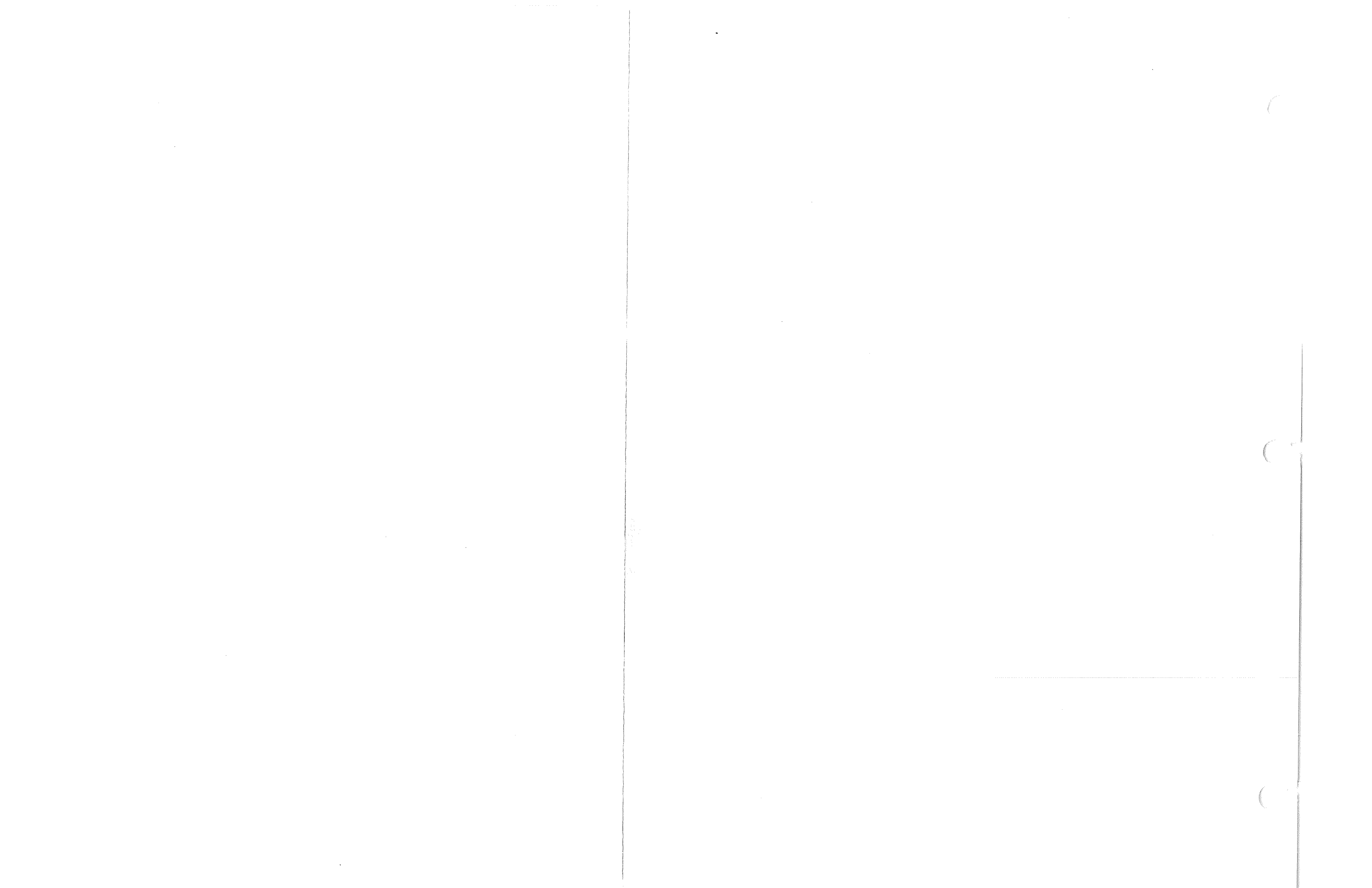

HARNES, CEILING

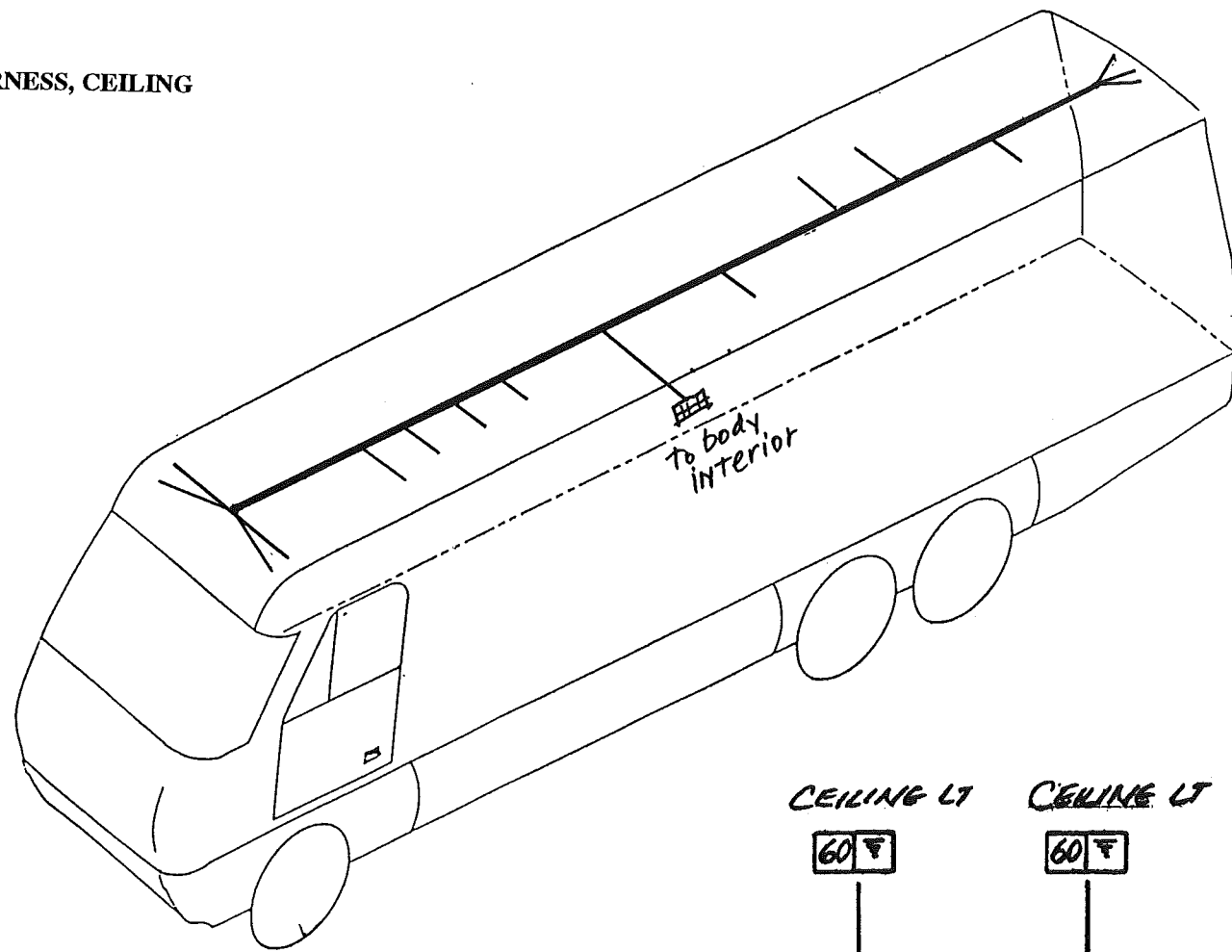

TO BODY INTERIOR
MALE TERMINALS

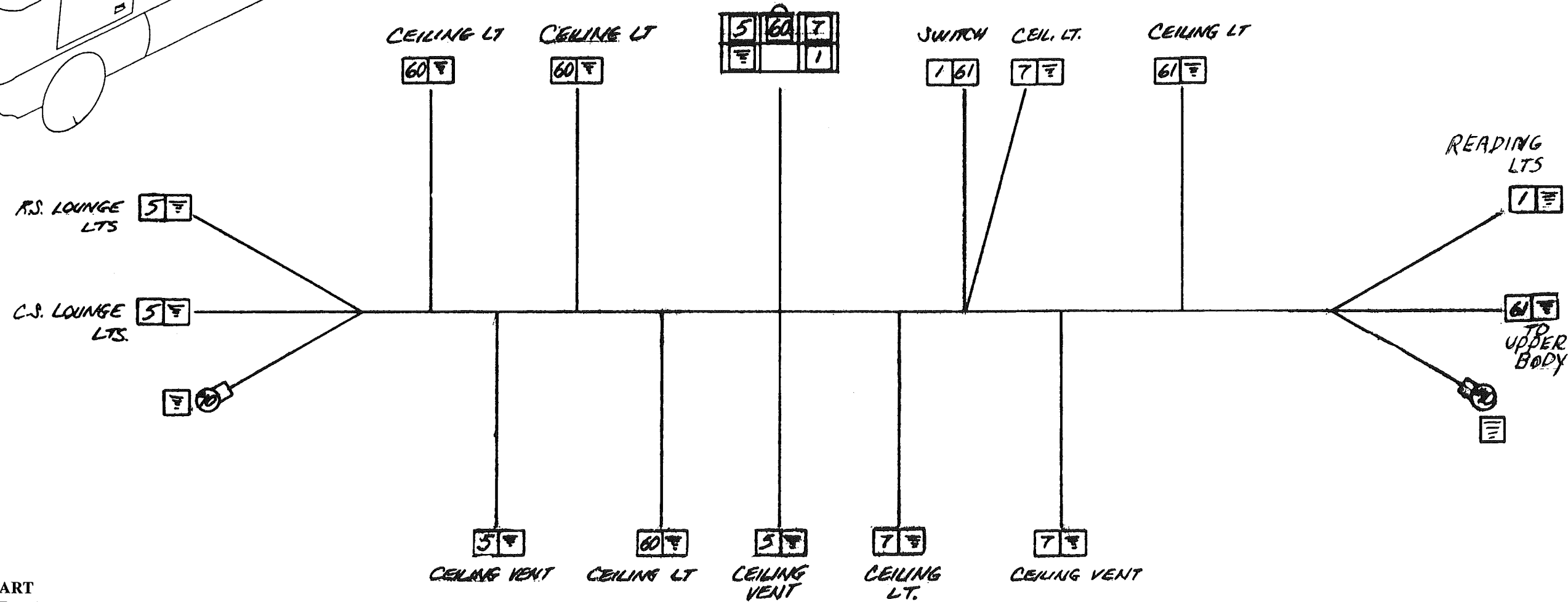

WIRE CHART

Circ.	Ga.	Color	Function
1	12	Purple	+12, Lights, Bed
5	12	Blue	+12, Lights & Vents
7	12	Black	+12, Light & Vent
60	12	Black/White	SWD, Ceiling Lt.
61	12	Purple/White	SWD, Lights, Bed

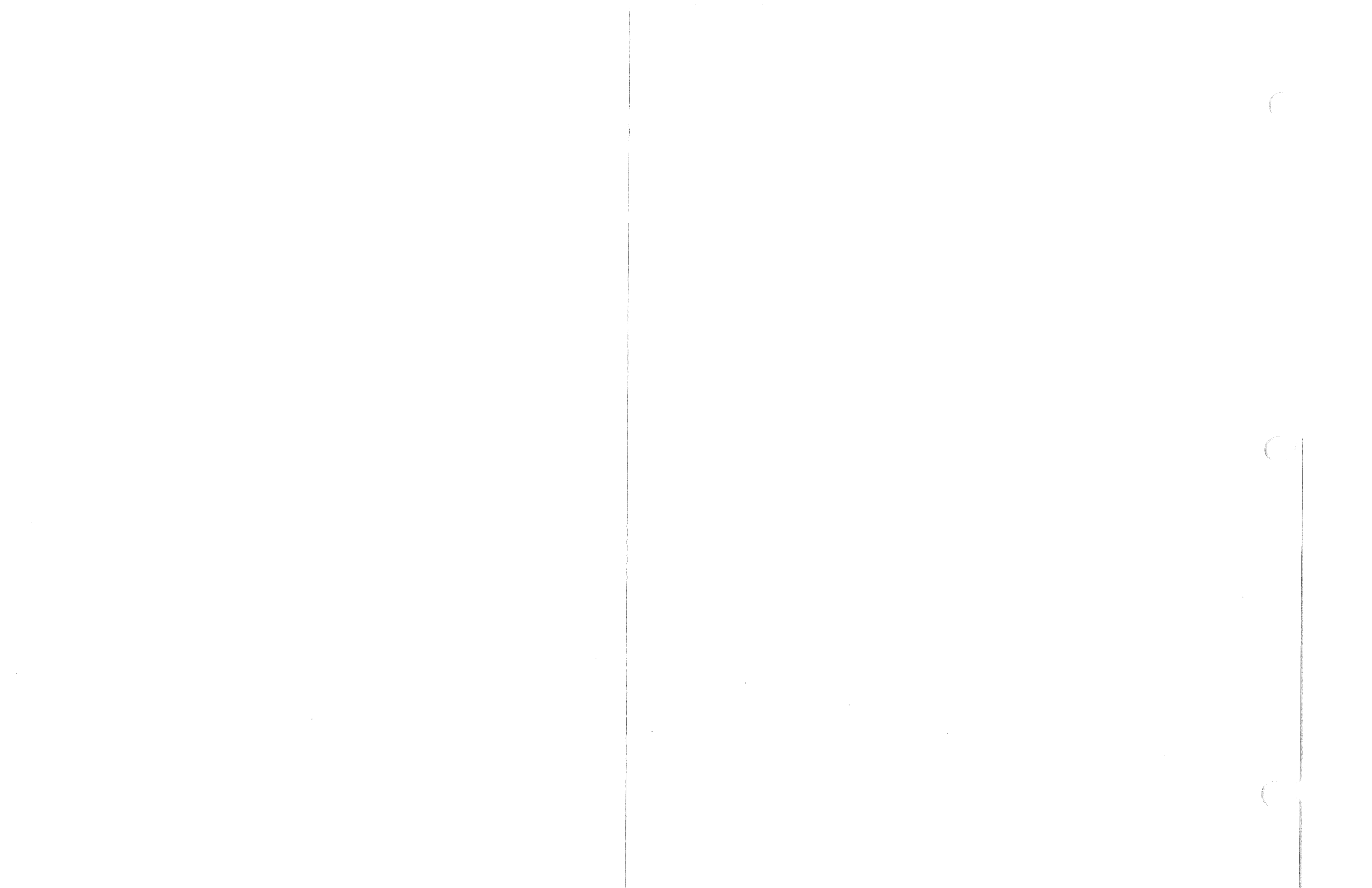

HARNES, BODY, CHASSIS PUSHER

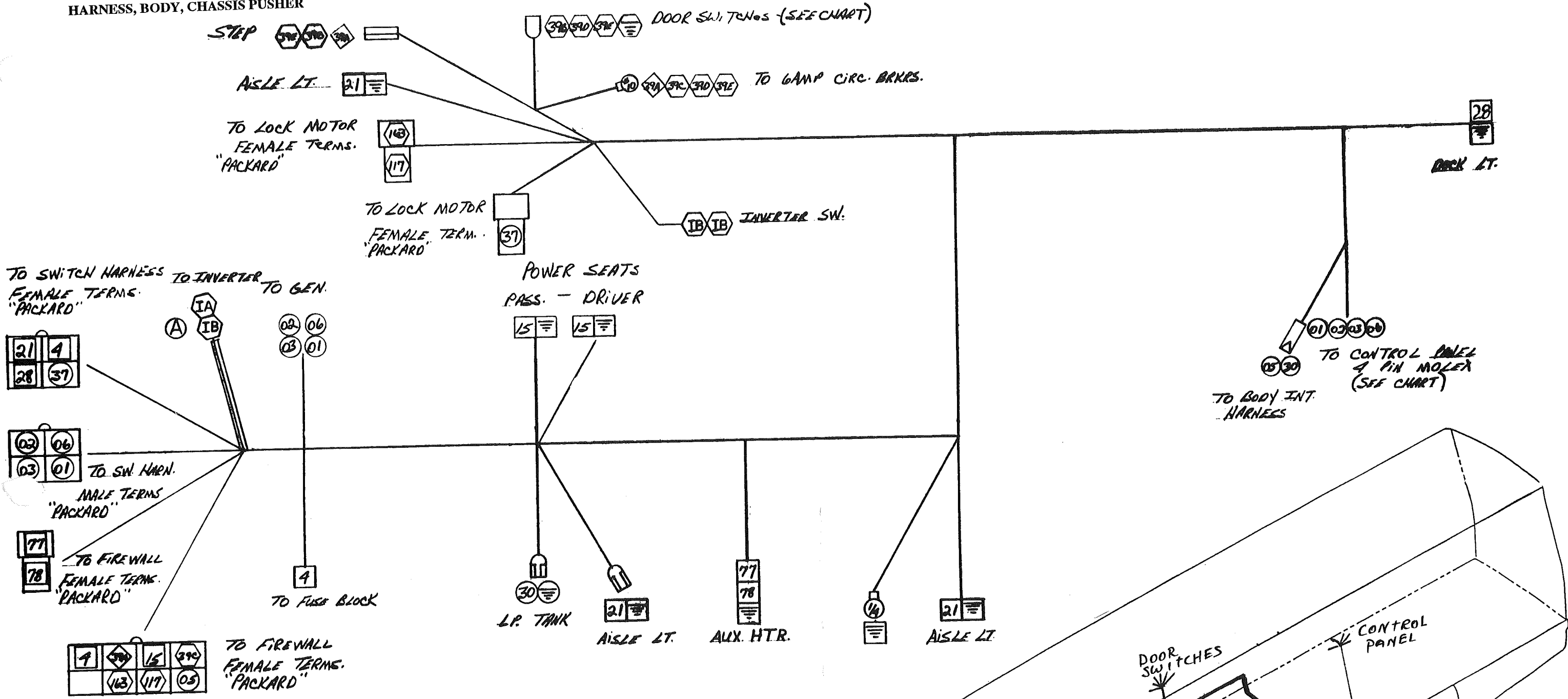

WIRE CHART

Circ.	Ga.	Color	Function	Circ.	Ga.	Color	Function
01	18	Black	Gen. (Ground)	39A	10	Red	Step +12v (Red)
02	18	Brown	Gen. (Stop)	39B	16	Red/Wh	Step SW. (White)
03	18	Yellow	Gen. (Start)	39C	16	Red	Step +12v Ign.
05	18	Orange	Gen. (Batt. Cond. Eng.)	39D	16	Red/Wh	Step SW.
06	18	Red	Gen. (Hour meter)	39E	16	Yellow	Step +12v Ign. (Yellow)
4	12	Brown	+12v	77	12	Red	Aux. Heat (Lo)
15	12	Red	Pwr. Seats	78	12	Orange	Aux. Heat (Hi)
21	12	Green	Aisle Lt.	117	16	Pink/Blk	Door Lock
28	12	Purple	Dock Lt.	163	16	Red/Org	Door Unlock
30	18	Lt. Blu/Wh	LP Tank	IA	16	Purple	Inverter Sw.
37	18	Blk/Red	Lock Ind. Lt.	IB	16	Orange	Inverter Sw.

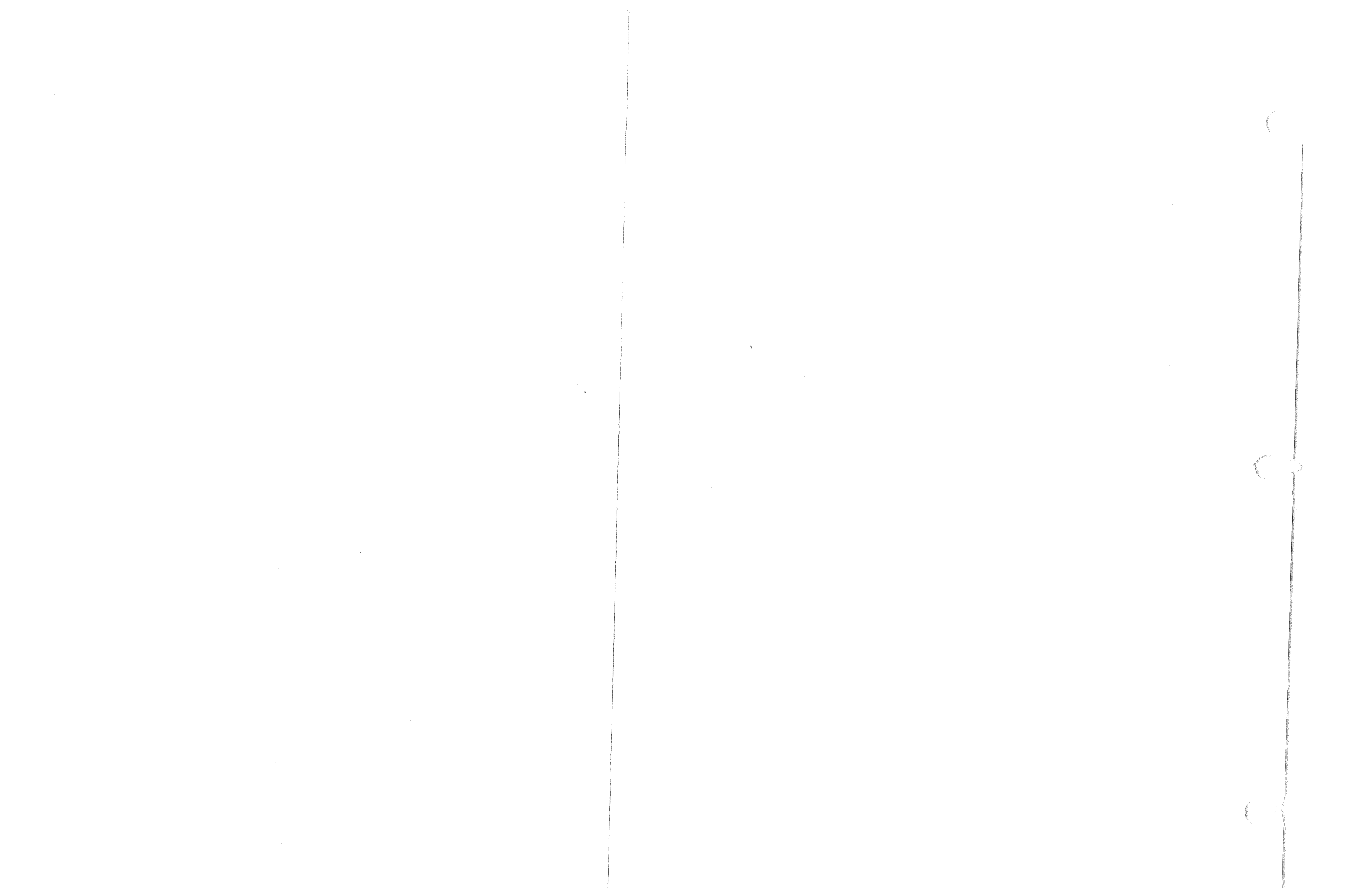

HARNES, FIREWALL PUSHER

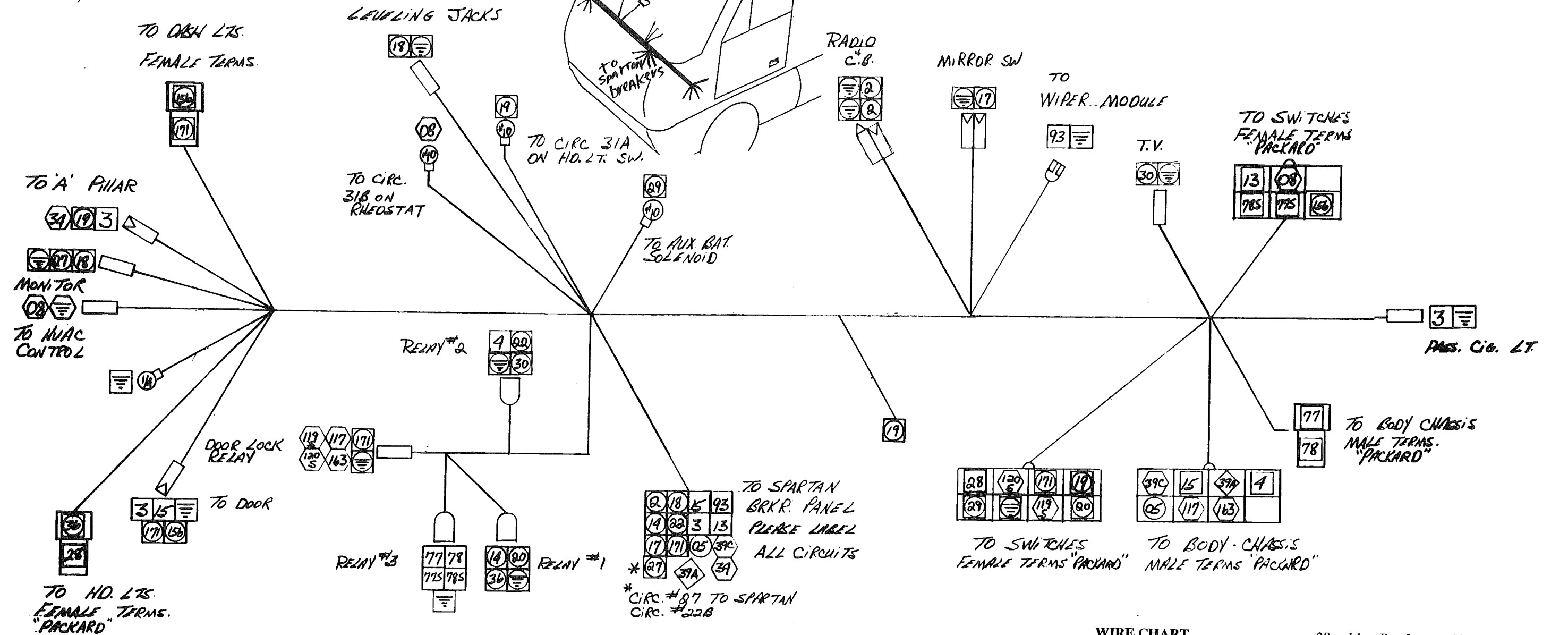

DOOR LOCK RELAY

Relay Wire Color	Circ. Color	Source
Black	120s. Pink	Switches
Green	119S Yellow	Switches
Red	171 Blk/White	Spartan Breaker Panel
White	≡	White
Orange	163 Red/Orange	Body Chassis
Blue	117 Pink/Blk.	Body Chassis

NOTES:
All Connectors wire side view

SWITCH CONNECTOR CHART

Relay #	Pin 30	Pin 85	Pin 86	Pin 87	Pin 87A
#1	14	≡	20	36	—
	Drive Lts.	14 Blue +12V	14 White	14 Blue/Wt. Switched To Drive Lts.	14 Red
#2	4	≡	22	—	30
	TV	12 Brown +12V	12 Wht.	14 Red +12V. Ign.	114 Purple To TV
#3	77S	≡	78S	78	77
	Aux. Heat.	12 Red/Org. Sw. Lo.	12 White	12 Org/White Sw. Hi	12 Orange Hi

SPARTAN BREAKER PANEL HOOK-UP

Live	Switched
15A. Type 2 Breaker Circ. # 2, 171, 34, 05	12A Type 2 Breaker Circ. # 18, 22, 39C
30A. Type 2 Breaker Circ. # 3, 15, 39A	20A Type 2 Breaker Circ. # 14, 17, 13
	25A Breaker Circ. # 93

WIRE CHART

Circ.	Ga.	Color	Function	Circ.	Ga.	Color	Function
05	18	Orange	Auto Batt. Level	30	14	Purple	T.V.
08	16	Gray	I.D. Its - Rheo.	34	16	Blue	Visor Lt.
2	14	Orange	Radio	36	14	Red	Drv. Lt. Pwr.
3	12	Orange	Cig. Lighters	39A	10	Red	+12v, Step
4	12	Brown	TV Power	39C	16	Red	+12v, Ign. Step
14	14	Blue	+12, Drive Lts.	117	16	Pink/Blk	Door Lock
15	12	Red	Pwr. Seat & Wind.	163	16	Red/Org.	Door Unlock
17	14	Orange	Mirrors	171	14	Blk/Wht	+12v, Door Locks
18	14	Yellow	Monitor	156	14	Green	Courtesy Lt.-Ground
19	14	Brown	Clearance Lts.	13	12	Blue	+12v, Aux. Heat
20	14	Blue/Wht.	Drive Lt. Relay	77S	12	Red/Org.	Aux. Heat Sw Lo
22	14	Red	+12v, Ign. SW.	78S	12	Org/Wht	Aux. Heat Sw Hi
27	14	Green	Monitor (Back-up Sw.)	77	12	Red	Aux. Heat Lo
28	12	Purple	Dock. Lts.	78	12	Orange	Aux. Heat Hi
29	14	Yellow	Aux. Start Sol.	93	12	Yellow	+12v, Wipers
				119S	16	Yellow	Door Sw Lock
				120S	16	Pink	Door Sw Unlock

MIRRORS, EXTERIOR

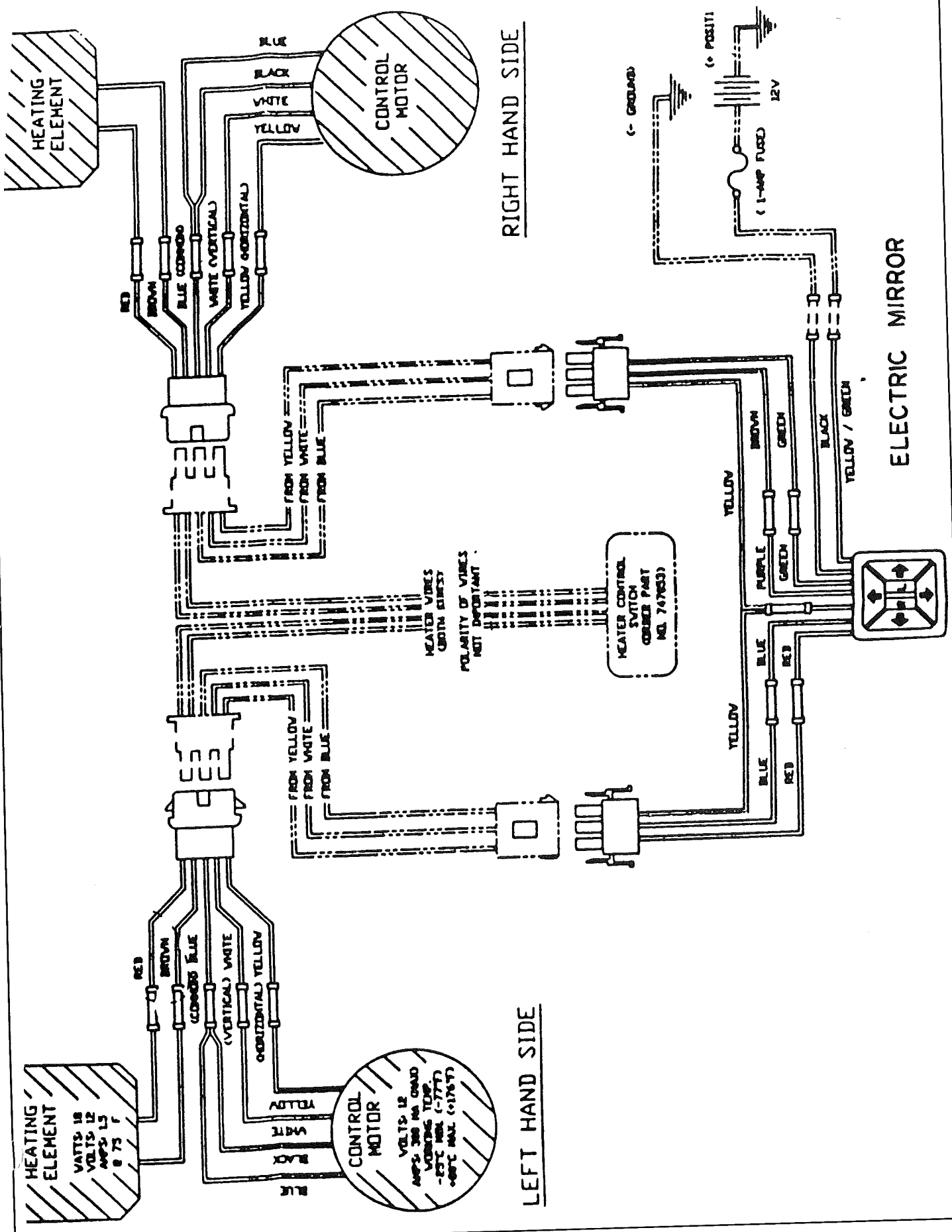

HARNESS, "A" PILLAR

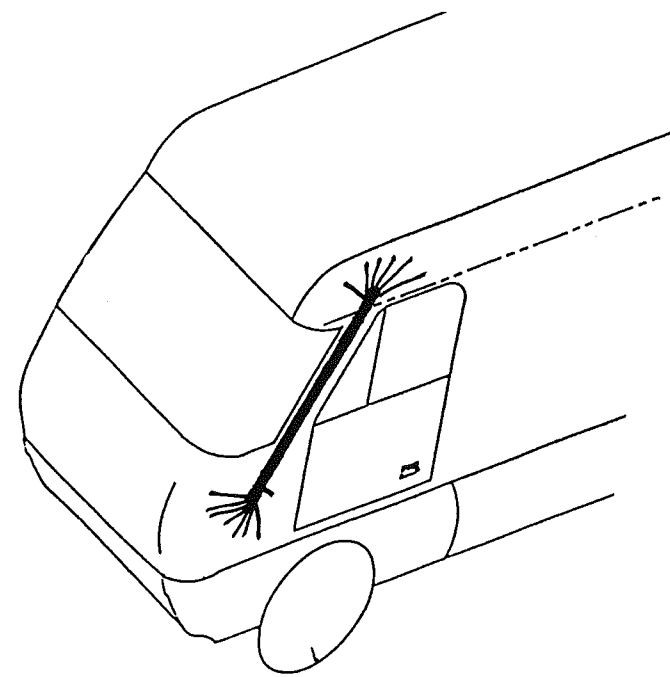
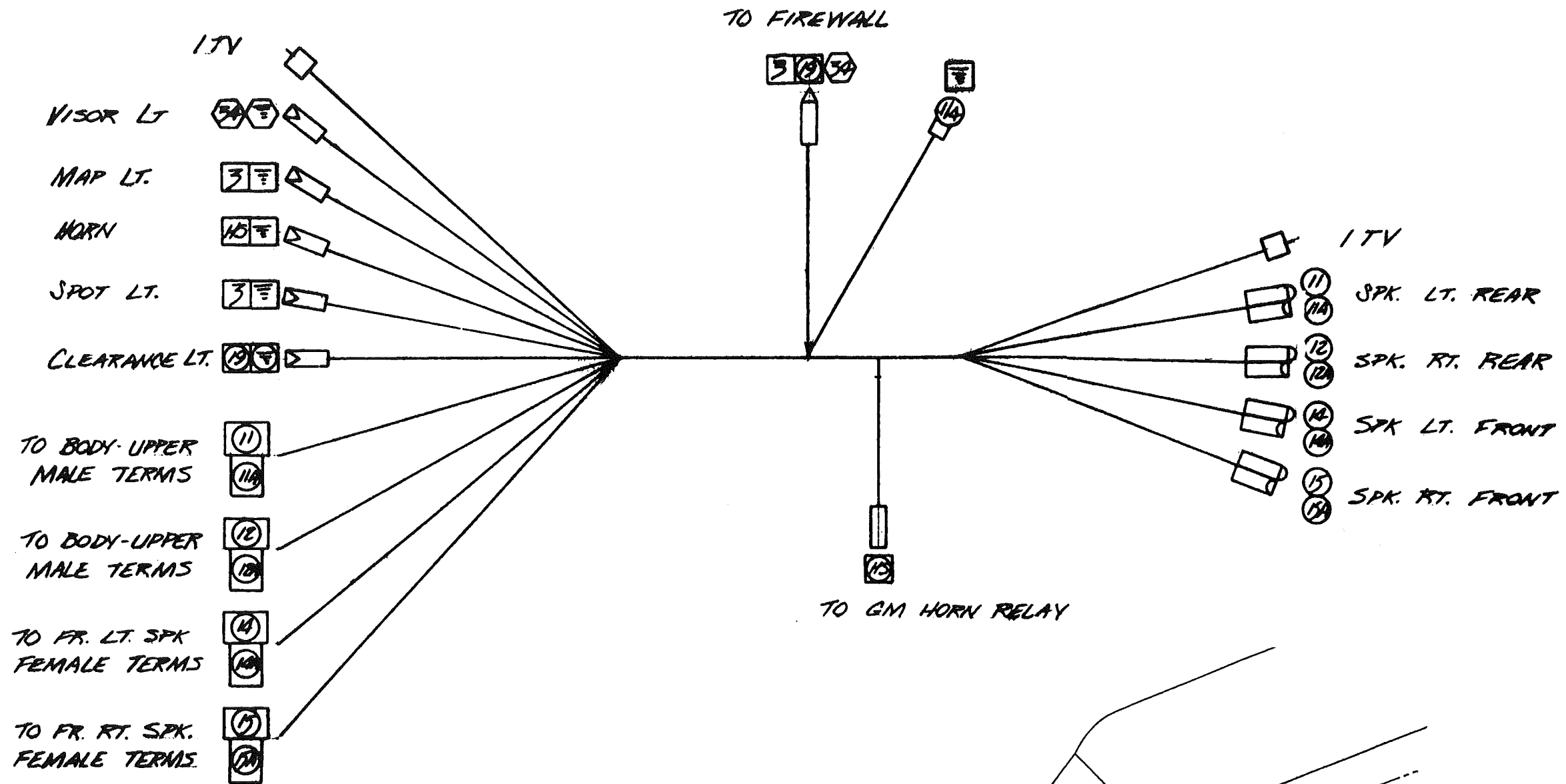

WIRE CHART

Circ.	Ga.	Color	Function	Circ.	Ga.	Color	Function
3	12	Orange	Spot + Map Lt.	14A	18	Black	Neg, Lt. Fr. Spk.
11	18	Gray	Pos., Lt. RR. Spk.	15	18	Red	Pos, Rt. Fr. Spk.
11A	18	Black	Neg, Lt. RR. Spk.	15A	18	Black/Wht	Neg, Rt. Fr. Spk.
12	18	Orange	Pos, Rt. RR. Spk.	19	14	Brown	Clearance Lts.
12A	18	Black/Wht	Neg, Rt. RR. Spk.	34	16	Blue	Visor Lt.
14	18	Blue	Pos, Lt. Fr. Spk.	HS	14	Green/Wht	Horn
				1TV		RG-59U Coax.	✓CR to Fr. TV

HARNESS, BODY, UPPER

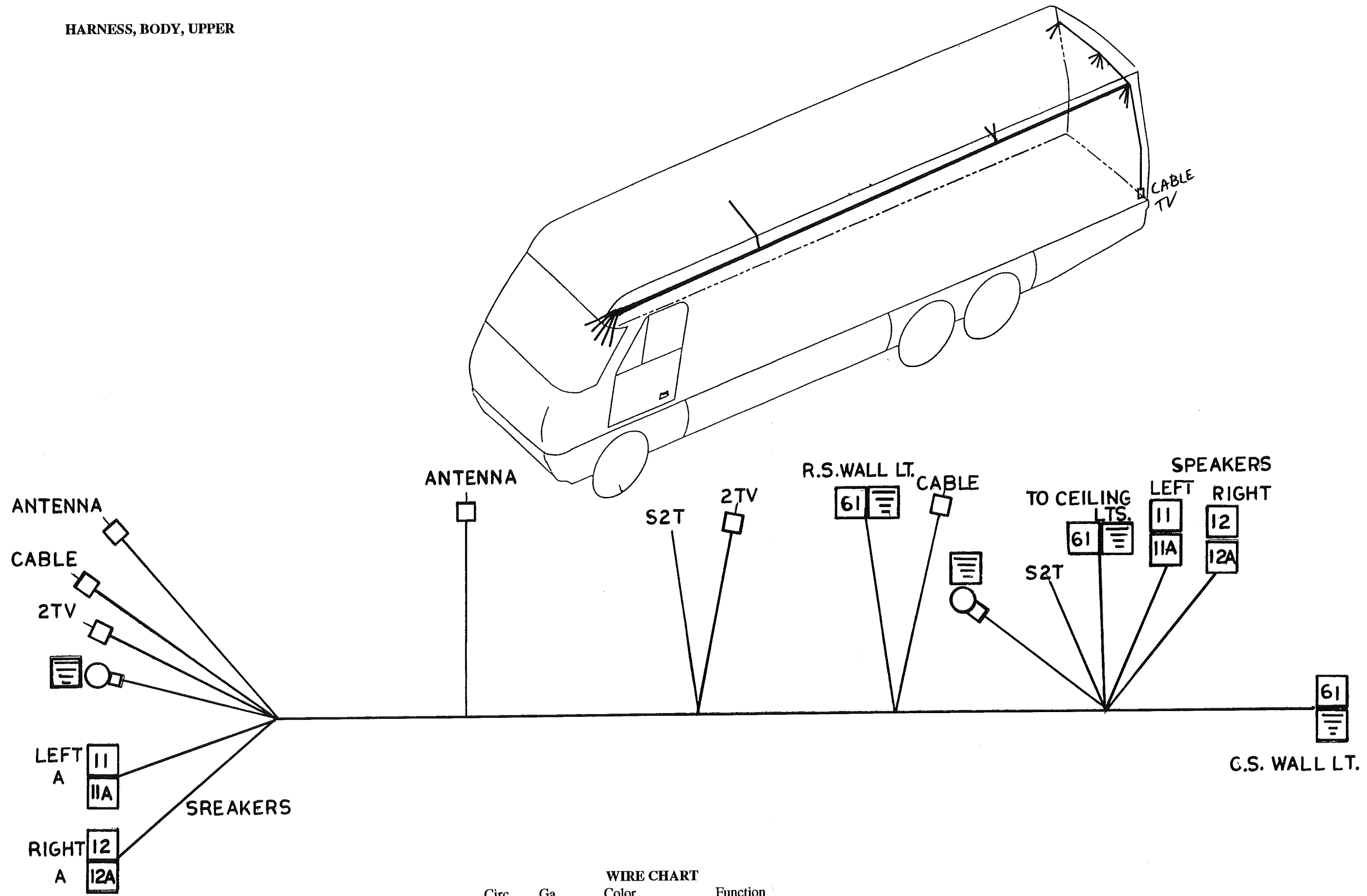

WIRE CHART			
Circ.	Ga.	Color	Function
11	18	Gray	Pos, Lt. RR. Spk.
11A	18	Black	Neg, Lt. RR. Spk.
12	18	Orange	Pos, Rt. RR. Spk.
12A	18	Blk/Wht	Neg, Rt. RR. Spk.
61	12	Purple/Wht	Bed. Lts. Swd.
S2T	18	Gray/Gray/Wht.	RR. TV REmote Spk.
Antenna	RG-59U	Coax	Antenna To VCR
Cable	RG-59U	Coax	Cable Inl. to VCR
2TV	RG-59U	Coax	VCR to RR. TV

MONITOR PANEL

Operation

To check tank capacities or battery condition,, depress the switch marked "test." In order to obtain a true reading on the batteries, you must be unplugged from city power and disconnected from your tow vehicle.

The red indicator light on the left marked "AC Power" will be illuminated when 120 volt alternating current is available. The light will be illuminated whether you're plugged into city power or if your generator is running. There is a built in delay if you're switching back and forth between the two power sources.

The two speed "Hood Fan" has an exterior door that must be unlatched to be effective. You'll see the two small twist latches if you look at the fan from outside the motorhome. In most circumstances you can leave the door unlatched. During storage or adverse weather conditions, latching the door is recommended.

Trouble Shooting Guide

Be sure the wiring to the panel is correct and that the house battery is well charged. All electrical connections must be correct.

NOTE: RV's are subjected to a lot of vibration from traveling on the highways, so always look for broken wires and loose or broken connections.

NOTE: If a RV has exposed holding tanks under the vehicle and the vehicle is operated in the rain, sleet or snow, the panel may show incorrect tank levels due to electrical conductivity on the outside of the tanks. Washing the tanks and sealing the connections on the outside of the well nuts with silicon sealer should correct this condition.

PROBLEM: Fan does not operate.

CAUSE: A. No voltage to switch.
B. Defective switch, defective motor.

REMEDY: 1. Check for voltage, test switch, test motor.

PROBLEM: Fan operates on high speed but not on low speed.

CAUSES: A. Defective circuit board.

REMEDY: 1. Replace circuit board.

PROBLEM: Hood light does not operate.

CAUSES: A. Burned out bulbs..
B. No voltage to switch.
C. Defective switch.

REMEDY: 1. Test for voltage.
2. Test switch.
3. Test bulbs.

PROBLEM: Water pump does not operate.

- CAUSES:**
- A. No voltage to pump.
 - B. Defective switch or pump.
 - C. Pump not grounded.

- REMEDY:**
- 1. Test for voltage at switch.
 - 2. Check ground.

PROBLEM: Water pump operates but red indicator light does not come on.

- CAUSES:**
- A. Faulty LED.
 - B. Faulty circuit board.

- REMEDY:**
- 1. Replace circuit board.

PROBLEM: "E" LED shows but indicator lights for amount of liquid in tank don't show.

- CAUSES:**
- A. Faulty connection in lead to tank.
 - B. Faulty circuit board.

- REMEDY:**
- 1. Check leads and connections at tank.
 - 2. Replace circuit board.

PROBLEM: Condition of battery is not indicated when switch is pushed.

- CAUSES:**
- A. Faulty switch.
 - B. Faulty circuit board.
 - C. Circuit board not grounded.
 - D. Dead battery.

- REMEDY:**
- 1. Test Test switch, check ground.
 - 2. Change circuit board.
 - 3. Charge battery.

PROBLEM: No "E" light on water tanks when switch is pushed.

- CAUSES:**
- A. No power to panel.
 - B. Defective circuit board.

- REMEDY:**
- 1. Check fuses and power leads.
 - 2. Repair or replace panel.

PROBLEM: Improper level indication on one or two tanks.

- CAUSES:**
- A. Faulty wiring from panel to sensors.
 - B. Faulty circuit board.
 - C. Dirty sensors and/or tank.

- REMEDY:**
1. Check wiring to sensors.
 2. Clean sensors and tank.
 3. Replace tank sensor harness.
 4. Replace or repair circuit board.

PROBLEM: Improper level indication on all water tanks.

CAUSES: A. Faulty circuit board.

- REMEDY:**
1. Replace or repair circuit board.

PROBLEM: Panel shows LPG tank to be full all of the time.

- CAUSES:**
- A. Connection between tank and panel faulty.
 - B. Poor or no ground between tank and vehicle.
 - C. Faulty tank sending unit or faulty circuit board.

- REMEDY:**
1. Check and repair wiring from tank to panel and tank to ground.
 2. Repair or replace tank sending unit.
 3. Repair or replace circuit board.

PROBLEM: Panel shows LPG tank to be empty all of the time.

- CAUSES:**
- A. Short to ground in wire between panel and tank sending unit.
 - B. Faulty tank sending unit.
 - C. Faulty circuit board.

- REMEDY:**
1. Repair shorted wire.
 2. Repair or replace sending unit.
 3. Repair or replace circuit board.

NOTE: If the wire from the panel is removed from the tank, the panel indicator should show the tank full. If the panel wire to the tank is grounded, the panel should show the tank empty.

TV ANTENNA

Manufacturer: Winegard Company
3000 Kirkwood Street
Burlington, Iowa 52601
Phone: 800-843-4741

Raising Antenna to Operating Position

Turn elevating crank in "UP" direction until some resistance to turning is noted. Antenna is now in operating position. Check to make sure switch on front TV jack is on.

Rotating Antenna

Make sure antenna is in "UP" position. Pull down on directional handle with both hands until it disengages ceiling plate and rotate for best picture and sound on television set.

Lowering Antenna to Travel Position

Rotate antenna until pointer on directional handle aligns with pointer on ceiling plate.

WARNING: Antenna must be in "down" position while traveling to prevent damage.

Turn elevating crank in the "Down" direction until resistance is noted. Antenna is now locked in travel position.

Checking Operation

1. Tune TV receiver to nearest station and rotate antenna for lowering Antenna best picture and sound.
2. Turn off switch on power supply. Picture on TV receiver should be considerably degraded with power off.

DO'S

1. Do check parking location for obstructions before raising antenna.
2. Do carefully raise, lower and rotate - if difficult, check for cause.
3. Do rotate slowly when selecting station and check fine tuning on TV set to make sure it is properly adjusted.
4. Do lower antenna before moving vehicle.

DONT'S

1. Don't force elevating crank up or down. Check for cause of trouble.
2. Don't rotate directional handle hard against stops.
3. Don't travel with lift in up position.
4. Don't leave lift part way up or down.
5. Don't apply sealing compound or paint over top of base plate or anywhere on lift.

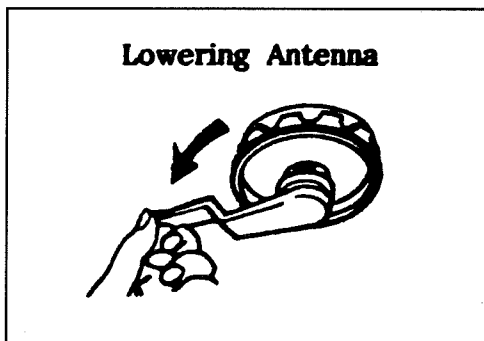
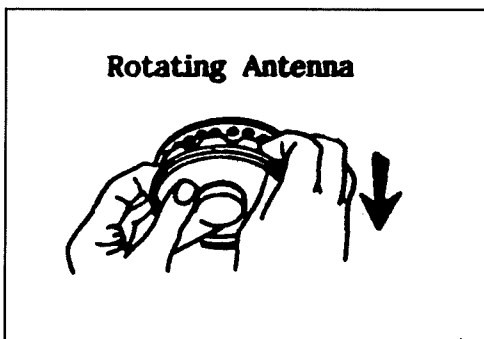
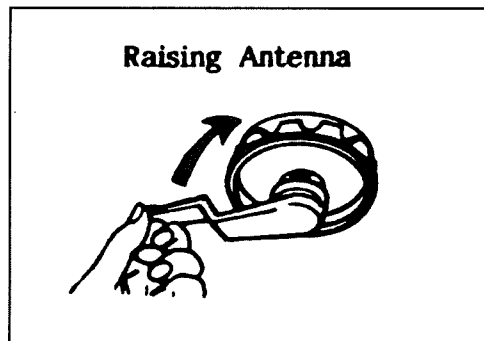

Maintenance

Lubrication

To lubricate the elevating gear apply a liberal amount of silicone spray lubricant to the elevating gear with the lift in the down position, then run the lift up and down a few times to distribute lubricant over gears.

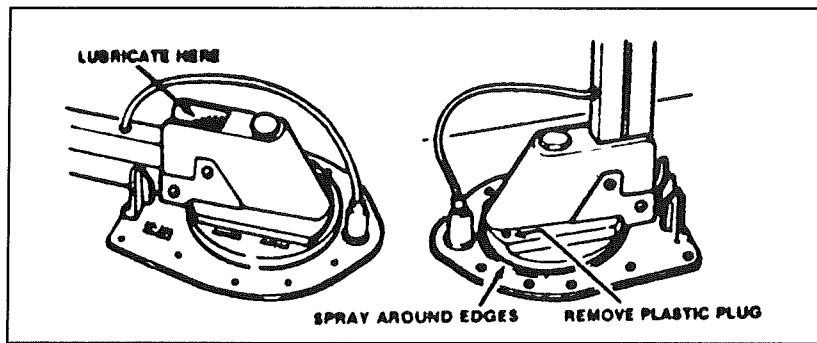

Lubricating Rotating Gear Housing

In the event that rotating the antenna becomes difficult, normal operation can be restored by lubricating the bearing surface between the rotating gear housing and the base plate. Any spray type silicone lubricant may be used.

Elevate antenna and remove set screw from rotating gear housing as shown. Spray lubricant into hole and around edges of gear housing. Rotate gear housing until lubricant coats bearing surfaces and antenna rotates freely.

Elevating Shaft Worm Gear Assembly Replacement Procedure

STEP 1: Lower antenna to travel position and refer to drawing to identify parts indicated in steps below.

STEP 2: Loosen set screw on elevating crank (#1) and remove crank (#1), spring (#2), directional handle (#3).

STEP 3: Go to roof of vehicle and Qs remove retaining ring from pin (#5) holding top elevator tube in rotating gear housing and remove pin.

STEP 4: Remove bearing plug (#4) from top of rotating gear housing. Disengage elevating gear (#6) and remove elevating shaft assembly (#7).

Note: Make sure all parts below worm gear are removed from rotating gear housing. These include bearing, quad ring and one or two washers.

STEP 5: Cut new shaft 1/4" longer than old shaft. See Illus: Discard old bearing plug item (#4).

STEP 6: Lubricate worm gear on new elevating shaft assembly with spray silicone lubricant, make sure quad ring, washer and wave washer are on lower bearing and insert assembly in housing.

STEP 7: Install new plastic bearing plug in top of housing. Re-engage elevating gear in worm gear. Replace pin and retaining ring.

STEP 8: Replace directional handle, spring and elevating crank. Make sure set screw contacts flat on shaft before tightening.

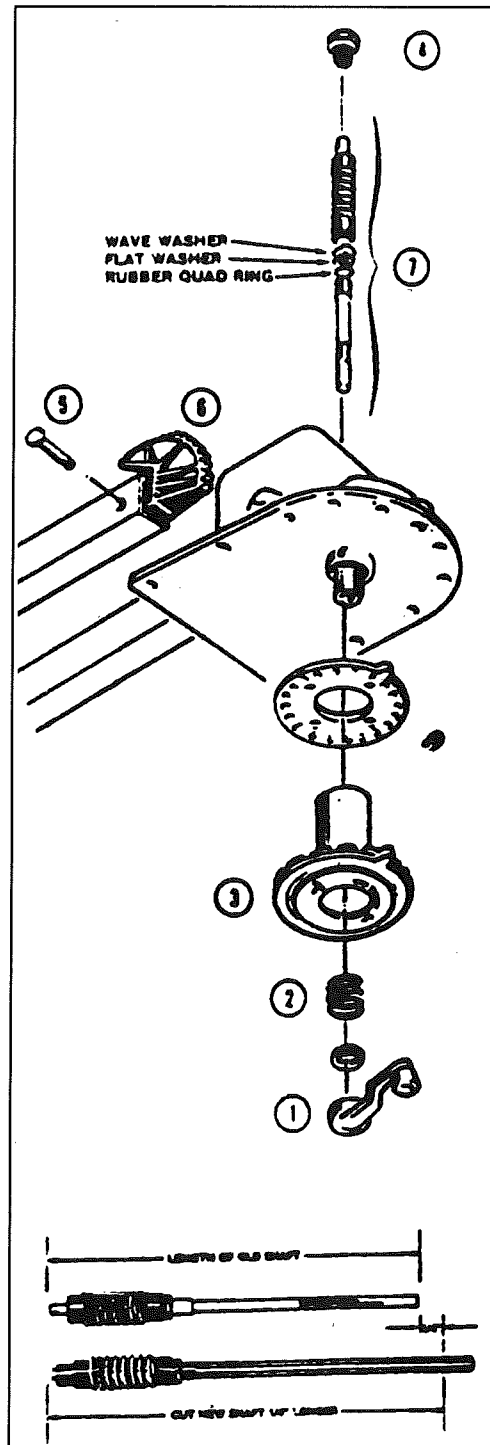

PARTS DESCRIPTION

1. Antenna Head
2. LM-300 Leveling Mount
3. Boot, Coax Cable
4. Pin, Headed/Grooved
5. Ring, Retaining Snap
6. Spacer, Plastic
7. Grommet, Plastic
8. EG-87 Elevating Gear
9. Tube, Square Elevator
10. Elevating Shaft Assy
11. Housing, Rotating Gear
12. Ring, Quad Seal
13. Bearing, Nylon
14. Housing, Base Plate
15. Bearing, Nylon
17. Plate, Ceiling
18. Screw
19. Handle, Directional
20. Spring, Handle
21. Decal, Crank Cover
22. Bearing, Nylon
23. Elevating Crank/Set Screw
27. Boot, Gear Housing
30. Bumper, Rubber
31. Screw

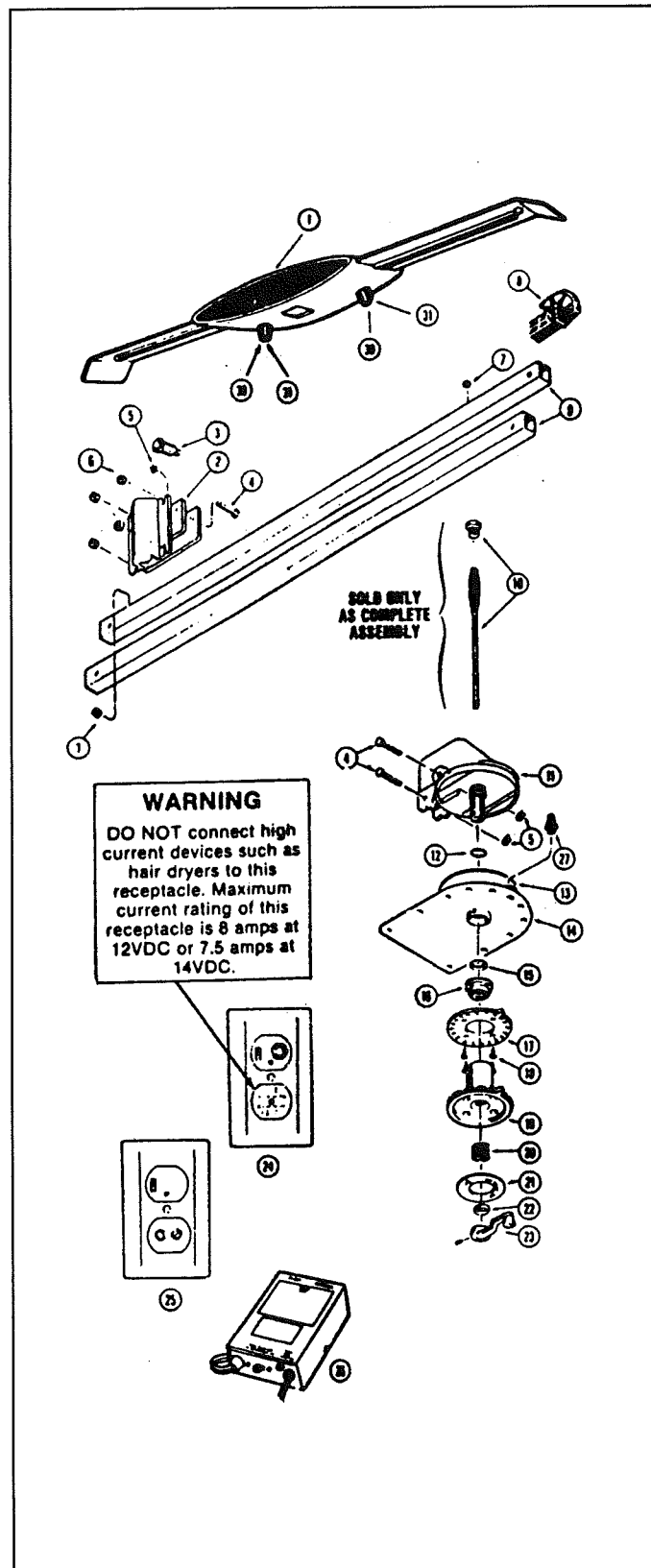

ANTENNA, RADIO, CB, CELLULAR TELEPHONE

Not including the TV antenna, your motorhome may have as many as three other antenna.

The **AM/FM radio antenna** is a solid whip type with a flexible coil base. The coil base certainly helps extend the life of the antenna but hitting low branches and other objects at high speed can lead to severe damage.

The optional **C.B. antenna**, if factory, installed will have been adjusted to obtain maximum performance and no further adjustment should be required.

The lead-in wire from the **cellular phone** antenna is coiled under the dash behind the kick panel in front of the passenger cab seat. The panel is removed by taking out the screws you can see through the vent grill and there are a couple of screws along the vertical right side of the panel.

110 VOLT POWER

The 110-volt system works very much like your home. When you're plugged into city power or start your generator, power is supplied to the 110-volt circuit breakers. The circuit breakers, located above the roadside rear night stand, then supply the power to the receptacles and appliances.

If a circuit is over loaded or a short circuit occurs, the breakers will "kick" out. To reactivate the circuits, turn the breaker to off, reduce the load or correct the short, and turn the breaker back to on.

One of the breakers is a GFI (Ground Fault Interrupter) breaker. The intent of this breaker is to sense any loss of ground before a harmful shock could occur, and kick the breaker out. These sensitive breakers are installed in the circuit feeding the bathroom, outside receptacle, and galley area. These are the areas where the use of water or the wet ground could put a person in danger of shock. Since the GFI breaker is so sensitive, it is not unusual to have it kick out for no apparent reason.

Getting power to your 110 volt circuits breakers is *nothing* like your home. Since you have two sources of 110 volt power, an automatic switch-over box is used. This prevents both sources of power from feeding your circuits at the same time and prevents your generator power from feeding the city circuits and shocking an unsuspecting lineman.

Generator/City Power

- A. to 110 volt circuit breakers
- B. to generator 30 amp circuit
- C. to city power

When plugged into city power, the current path is from C to A. When you start your generator and unplug from city power, the points switch and the power flow is from B to A. If you're plugged into city and you start the generator, city power has the priority, so the current flow is C to A.

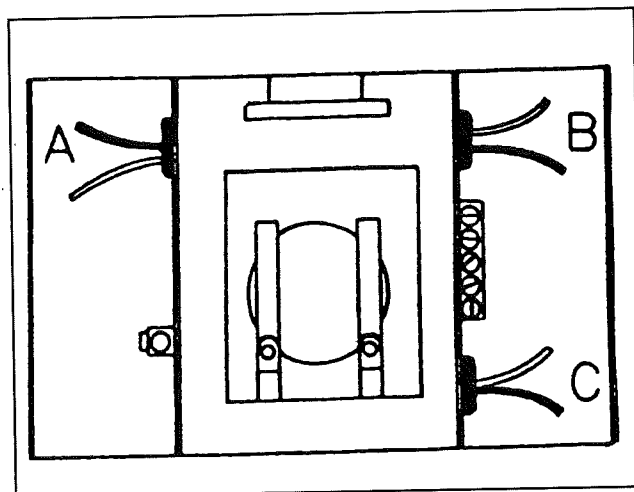

Rear Air Conditioner

- A. to rear air conditioner
- B. generator 20 amp circuit
- *C. to front/rear air conditioner priority switch

*If you have the optional 50-amp power cord service, C would go to the 20-amp leg of this service.

When plugged to city power with the optional 50-amp service cord or the front/rear priority switch is turned to rear, current flow is C to A.

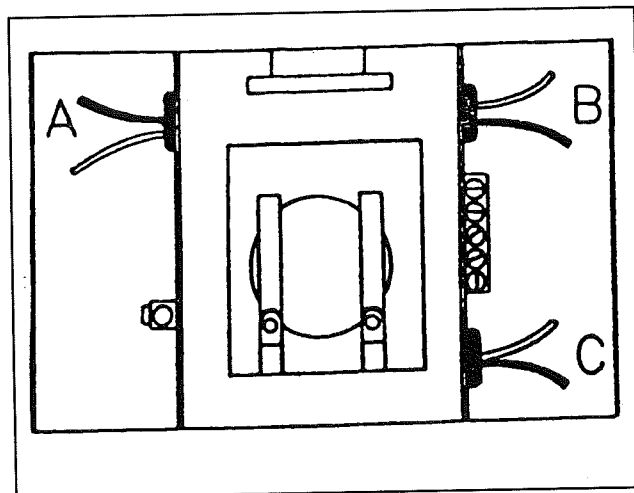

Locating Shorts and Opens

The key in locating shorts and opens is isolation. The first step is to isolate the circuit with the short or open. The second step is to then isolate the section of the circuit with the fault. Once the section is identified, the specific problem can be located. The cause may be a loose or corroded connection, cut wire, worn insulation, defective component, etc. The following procedure is one method for isolating shorts and opens.

SHORTS

1. Isolate the circuit which has the short by noting which circuit breaker has tripped.
2. Disconnect the power inlet cord from the power source.
3. Using the 120V schematic as a reference, disconnect outlet boxes one at a time starting at the box furthest from the distribution panel. After disconnecting each box, check for continuity between the black wire and ground or common (white) wire on the distribution panel side of the circuit. When a continuity light or ohmmeter indicates no continuity, the short is either in the receptacle just removed or the section of Romex wire between this receptacle and the previous receptacle removed.
4. Examples of a short are: A) The black wire of the 120V system contacting the white wire, bare wire or grounded surface. B) An internal short in a 120V appliance.

Any damaged wire must be replaced. The National Electrical Code does not permit splicing 120V wiring outside an outlet box or junction box. Also, the wire must not be exposed to an area such as a sharp metal edge which may damage the wire.

OPENS

1. Check all receptacles and components for voltage on the circuit which has the open.
2. If all receptacles and components of the circuit are without power, begin to look for open in the distribution panel.
3. Inspect for loose or corroded connections and a faulty circuit breaker.
4. Check for power on both ends of circuit breaker. If there is no power on the inlet side of the circuit breaker, the open is between the power cord's male connector and the distribution panel.
5. The open can be isolated by noting the outlets which do not have power. Example: If the bath outlet in the rear bath model has power and the converter has no power, the open is between the bath outlet and converter outlet.
6. Examples of an open are: A) Loose or corroded connections. B) A wire disconnected from a terminal. C) Contacts in the circuit breaker which do not make contact. D) A broken wire.

120V WIRING DIAGRAMS

- **120 volt distribution**
- **120 volt distribution panel**

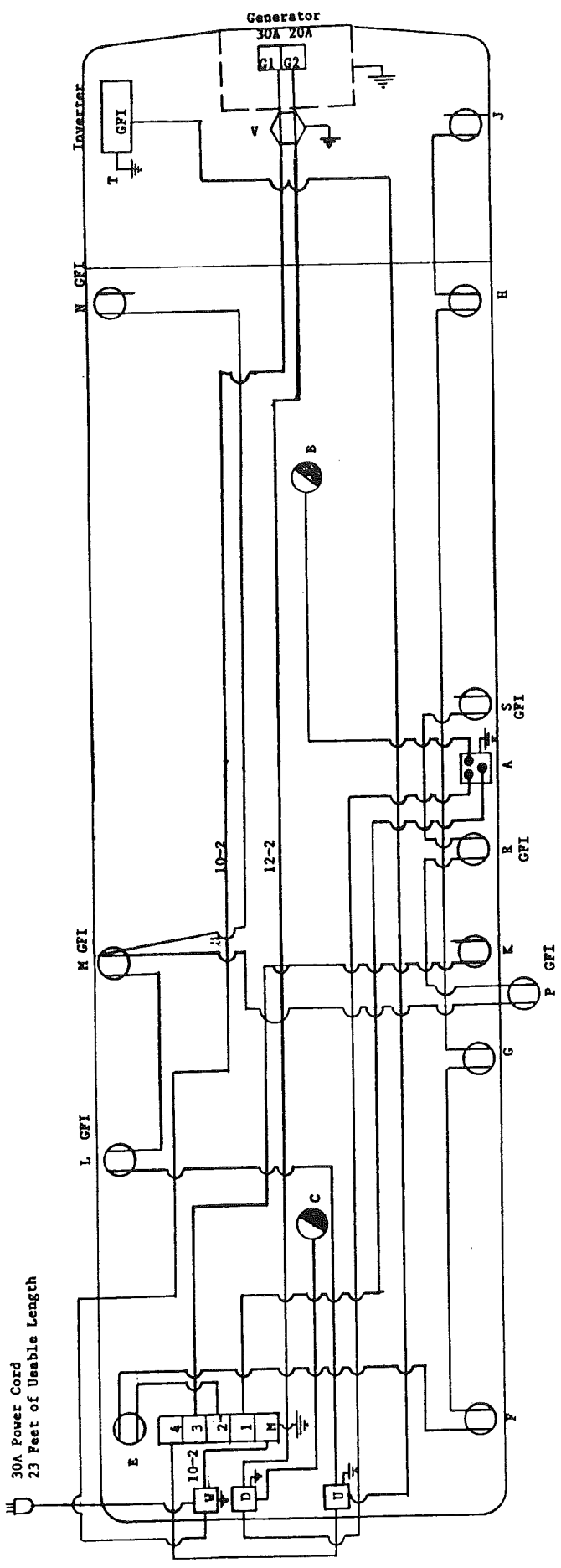

Generator Circuit G-2
 From the 20AMP breaker (Supplied with the generator) 12ga. stranded wire is run in flexible metal conduit to J-box "V". From here 12-2 Romex w/ground is run to automatic switcher relay "D". When the generator is operating, relay "D" will override shoreline and operates the rear A/C.

Circuit 4, 20AMP. GFI Breaker, 12-2 Romex W/Ground

L. Bath recept.	1.00 AMPS.
M. Dinette Recept.	1.00
N. VCR recept.	.23
P. Outside recept.	1.00
R. Kitchen recept.	1.00
S. Kitchen recept.	1.00
Total	5.23 AMPS.

When inverter "T" is operating it will supply GFI protected power to the recepts of Circuit 4. The inverter will override shore power through automatic switcher : relay "U".

Generator Circuit G-1
 From the 30 Amp. breaker (supplied with the generator) 10ga. stranded wire is run in flexible metal conduit to J-box "V". From here, 10-2 Romex with ground is run to the breaker box through automatic switcher relay "W".

Main Breaker, 30AMP.
 Circuit 1, 20AMP. HACR Breaker, 12-2 Romex W/Ground
 This circuit, when operating from Shoreline, supplies power to single pole, double throw priority switch "A" which will operate either front A/C "B" or rear A/C "C" (10AMP. Max.) depending on switch position. When the generator is operating automatic switcher relay "D" will override shoreline and operate rear A/C "C" with power supplied through generator circuit G-2. If priority switch "A" is in the front A/C position it will operate front A/C "B" with power supplied through generator circuit G-1.

Circuit 2, 20AMP. HACR Breaker, 12-2 Romex W/Ground

E. Roadside bedroom recept.	1.0 AMPS.
F. Curbside bedroom recept.	1.0
G. Refer. recept.	2.7
H. Credenza recept.	1.0
J. Converter recept.	8.0
Total	13.7 AMPS.

Circuit 3, 20AMP. HACR Breaker, 12-2 Romex W/Ground

K. Microwave oven	12.5 AMPS.
-------------------	------------

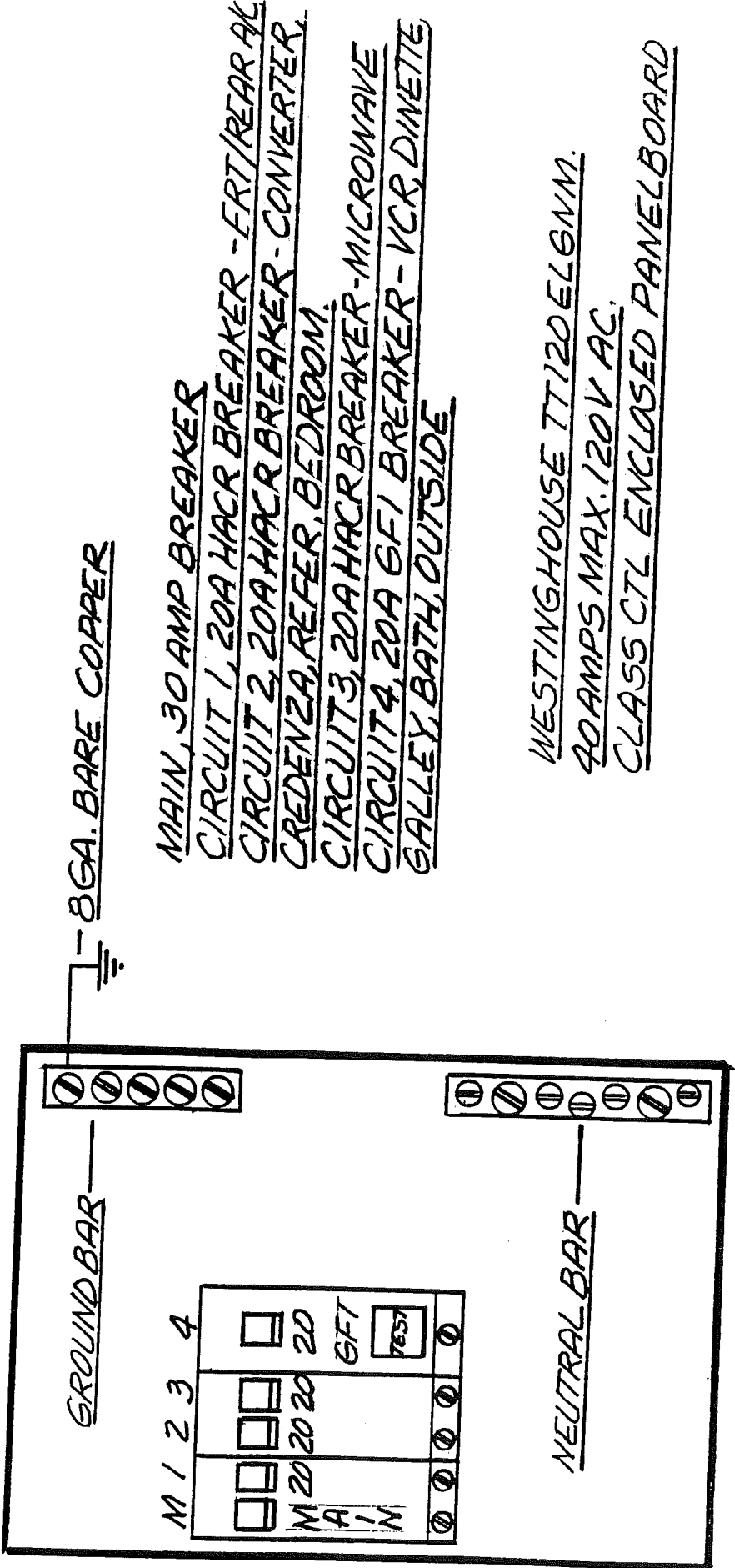

8GA. BARE COPPER

MAIN, 30 AMP BREAKER
CIRCUIT 1, 20A HACR BREAKER - FRT/REAR AC
CIRCUIT 2, 20A HACR BREAKER - CONVERTER,
CREDENZA, REFER, BEDROOM.
CIRCUIT 3, 20A HACR BREAKER - MICROWAVE
CIRCUIT 4, 20A GFI BREAKER - VCR, DINETTE
GALLEY, BATH, OUTSIDE

WESTINGHOUSE TT120EL6NM.
40 AMPS MAX. 120V AC.
CLASS CTL ENCLOSED PANELBOARD

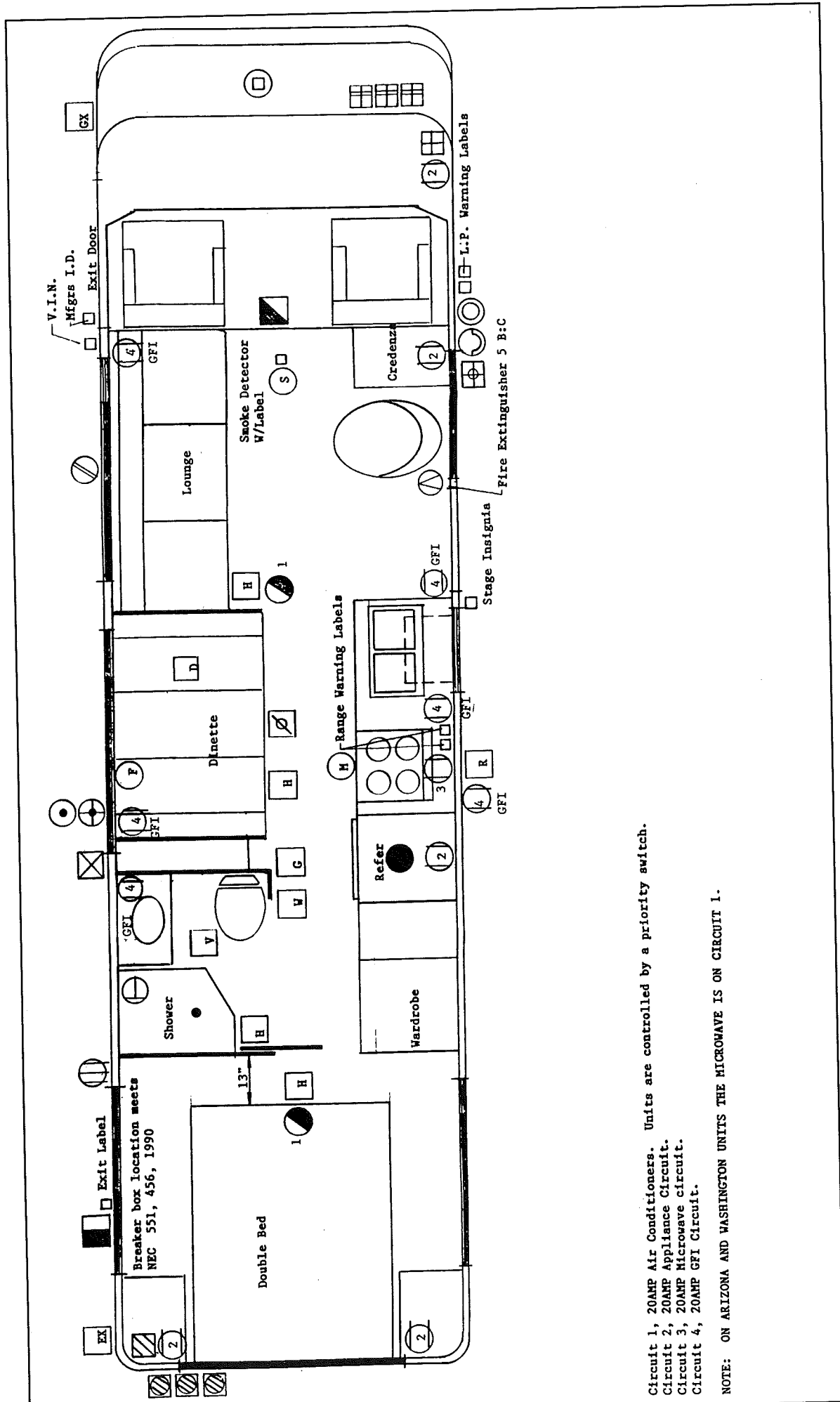

Circuit 1, 20AMP Air Conditioners. Units are controlled by a priority switch.
 Circuit 2, 20AMP Appliance Circuit.
 Circuit 3, 20AMP Microwave circuit.
 Circuit 4, 20AMP GFI Circuit.

NOTE: ON ARIZONA AND WASHINGTON UNITS THE MICROWAVE IS ON CIRCUIT 1.

APPLIANCES

AIR CONDITIONER

Manufacturer: Dometic Sales Corporation
2320 Industrial Parkway
P.O. Box 490
Elkhart, IN 46515
Phone: 219-295-5228

Note: Review the air conditioning literature supplied in your Owner's Packet before proceeding.

The roof air conditioner used on Airstream Land Yacht motorhomes is one of the most popular on the market today. In your Owner's Packet is a set of literature covering all operating and maintenance instructions. If the literature is misplaced, please contact the air conditioner manufacturer or your Airstream dealer for replacement. A detailed service guide may be ordered from the manufacturer.

Because of the amount of power drawn by the air conditioners, it is only possible to operate one at a time when plugged into city power. A wall switch, located above the kitchen counter, allows you to operate either the front or rear air conditioner, but not both at the same time.

Another appliance drawing a lot of current is the microwave. Operating the microwave and an air conditioner at the same time will put your electrical system at the edge of maximum draw. If the air conditioner goes into a "start up" cycle, the additional current will probably cause your main circuit breaker to kick out. If this situation occurs it is best to leave the air conditioner off for the few minutes the microwave is normally operated.

Both air conditioners may be operated when the generator is running or if you have optional 50 amp service. Set the priority switch to the front air conditioner and it is powered through the normal circuit. The generator powers the rear air conditioner through a separate circuit.

The voltage to the air conditioner is critical. We commonly refer to 110 or 120 volts, but a check with a volt meter may find voltage much lower. Your air conditioner will probably not function if the current drops below 105 volts. Low voltage is usually associated with older or poorly maintained trailer parks, but many people have found their homes, built only twenty or thirty years ago, may not be capable of operating the air conditioner on some receptacles. Parking your motorhome so the power cord can be plugged into a receptacle close to the fuse or circuit breaker box can alleviate the problem. Avoid extension cords and adapters whenever possible. If an extension cord must be used, it should be as short and heavy as possible to provide the most current to the air conditioner.

If high temperatures are expected, you should make an effort to park in a shaded area. Starting the air conditioner early in the morning also helps. It is much easier to hold a comfortable temperature than it is to lower the temperature after the interior of the motorhome is already hot.

OPERATING INSTRUCTIONS

(Model 610015.405)

CONTROL DESCRIPTION:

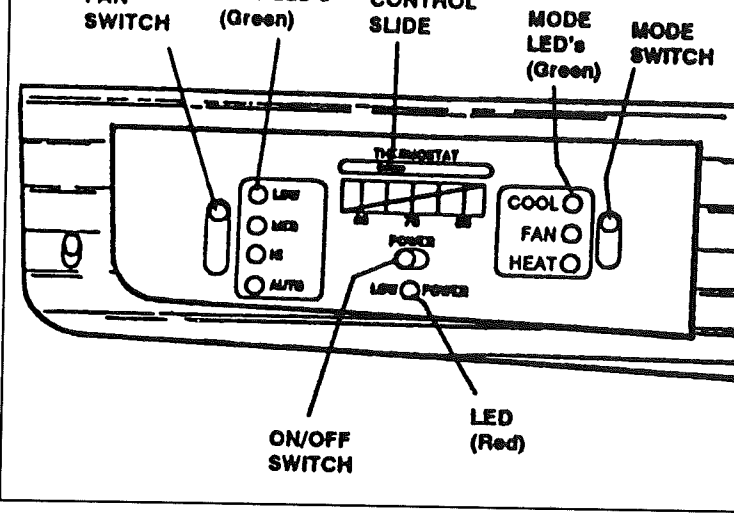
1. **Power Switch:**
 - a. Located lower center of control.
 - b. Turns air conditioner ON to set condition of FAN and MODE switch.
 - c. Turns air conditioner OFF.
 - d. Green LED lights next to FAN and MODE switch light up to indicate power ON.
 - e. No LED lights on when control is OFF.
 2. **Mode Switch:**
 - a. Three position switch located on right side of control.
 - b. Used to select COOLING, FAN or HEAT mode of air conditioner operation.
 - c. Mode selected is indicated by green LED light when control is turned on.
 3. **Fan Switch:**
 - a. Four position switch located on left side of control.
 - b. Used to select HIGH, MEDIUM, LOW or AUTOMATIC FAN operation.
 - c. Fan speed selected is indicated green LED light when control is turned on.
 4. **Temperature Slide:**
 - a. Located top center of control.
 - b. Moveable arm on control selects temperature at which the refrigerant compressor or electric heater (if so equipped) is turned ON and OFF.
 - c. User sets to position to maintain temperature level desired.
 5. **Low Power Light:**
 - a. Red indicator light located lower center of control.
 - b. When on it indicates AC voltage is below 97 volts AC.
 - c. Unit continues to operate (see Special Control Features E.4)
 - G. **Remote Power Switch Connection:**
 - a. Two screw terminals located on back side of control.
 - b. Used to connect a remote ON/OFF switch.
 - c. Remote ON/OFF switch, if used, operates same as power switch. (See Special Control Features E.5)
- 
- The diagram shows a rectangular control panel with several components labeled. On the left side, there is a 'FAN SWITCH' with four positions labeled 'LOW', 'MED', 'HI', and 'AUTO'. Next to it is a 'FAN LED's (Green)'. In the center, there is a 'TEMPERATURE CONTROL SLIDE' with a scale and a 'THERMOSTAT' label. Below the slide is an 'ON/OFF SWITCH' and a 'LED (Red)'. On the right side, there is a 'MODE SWITCH' with three positions labeled 'COOL', 'FAN', and 'HEAT'. Next to it is a 'MODE LED's (Green)'. The panel also features a '9' symbol on the left and a 'THERMOSTAT' label above the slide.

SPECIAL CONTROL FEATURES:

COOLING MODE OPERATION

1. Turn POWER switch (or REMOTE switch if used) to ON position.
2. Place mode switch COOL position.
3. Set temperature slide switch to your desired temperature level.
4. Select your desired fan speed.
NOTE: See Special Features Section E.1 for AUTO fan operation.
5. The fan starts immediately and after a delay of approximately two minutes, the compressor will start.
6. The fan runs continuously with the compressor cycling ON/OFF per the set point to maintain an even comfort range.

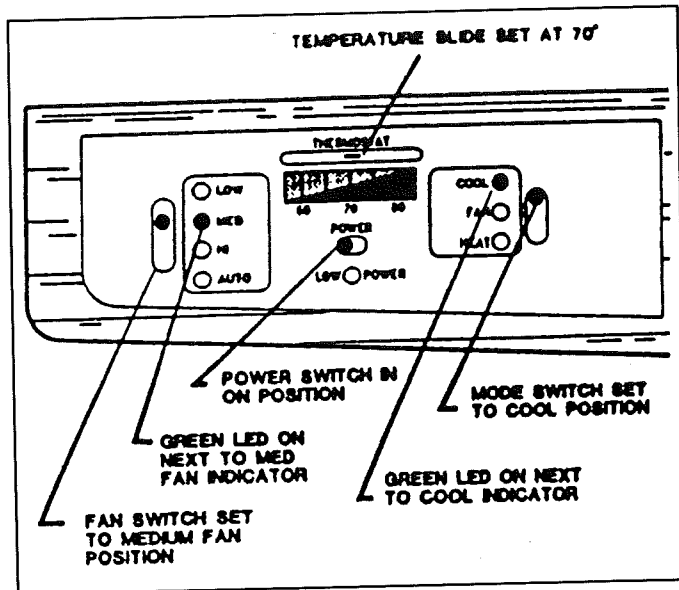

FAN MODE OPERATION

1. Turn POWER switch (or REMOTE switch if used) to ON position.
2. Place MODE switch in FAN position.
3. Select the desired fan speed: HI-MED-LOW-AUTO.
NOTE: in AUTO position the fan operates only at low speed in FAN mode of operation.

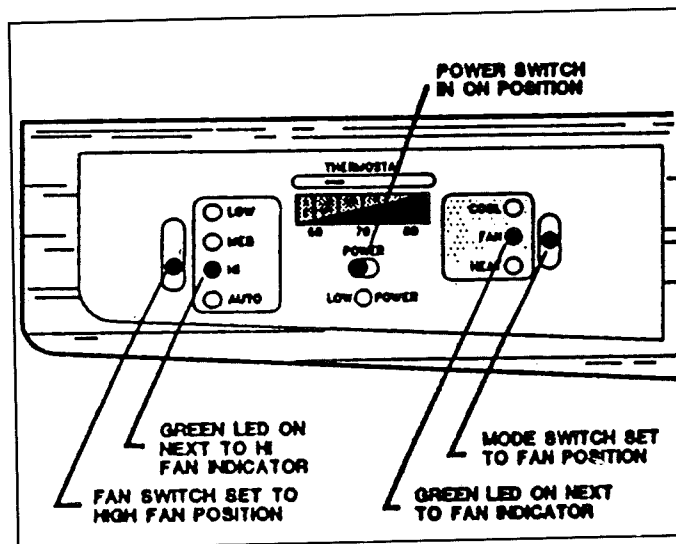

HEAT MODE OPERATION

1. Turn POWER switch (or REMOTE switch if used) to ON position.
2. Place mode switch in HEAT position.
3. Set temperature slide switch to your desired temperature level.
4. Select your desired fan speed HI-MED-LOW-AUTO)
NOTE: in AUTO position the fan operates only at low speed in HEAT mode of operation.
5. The fan runs continuously with the electric heater cycling ON/OFF per the set point to maintain an even comfort range.

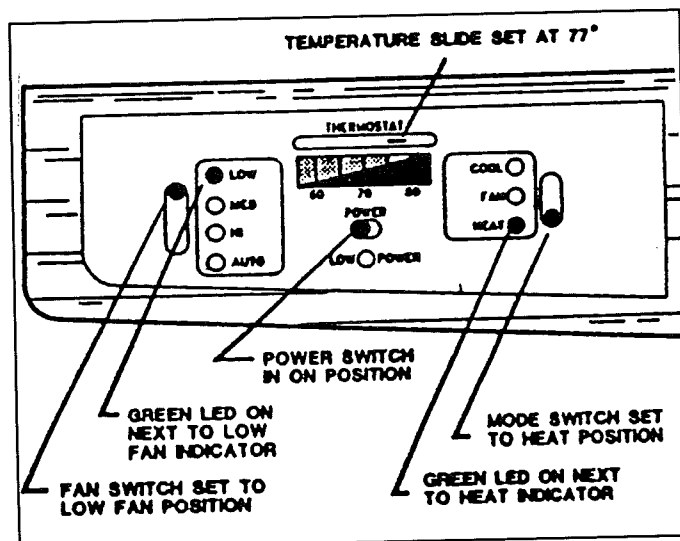

SPECIAL CONTROL FEATURES:

1. **Auto Fan:** When selected, FAN switch will:

- a. Automatically select the fan speed depending on the difference between set temperature and room temperature.
- b. Temperature difference of:
 - 8° or more
Fan operates on HIGH
 - 4° to 8°
Fan operates on MEDIUM
 - 4° or below
Fan operates on LOW

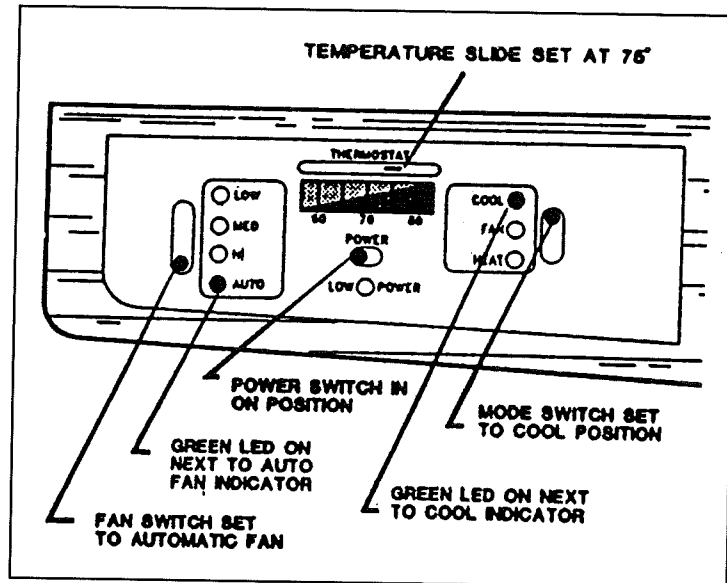

2. **Refrigerant Compressor Time Delay:**

The compressor will always have a delay in starting of approximately two minutes any time it is required to start.

3. **Power Interruption:**

In the event power to the air conditioner is interrupted for any reason, the system will restart in the condition previously set by user.

4. **Low Power Indicator:**

The red light will come on any time AC voltage drops below 97 volts AC for more than ten seconds. The light will remain on until the voltage is above 103 volts AC. The air conditioner will continue to run when red light is on as long as sufficient power is available to compressor to keep it running. NOTE: If red light is on, investigate the cause of the low voltage condition and correct to insure efficient operation of the air conditioner.

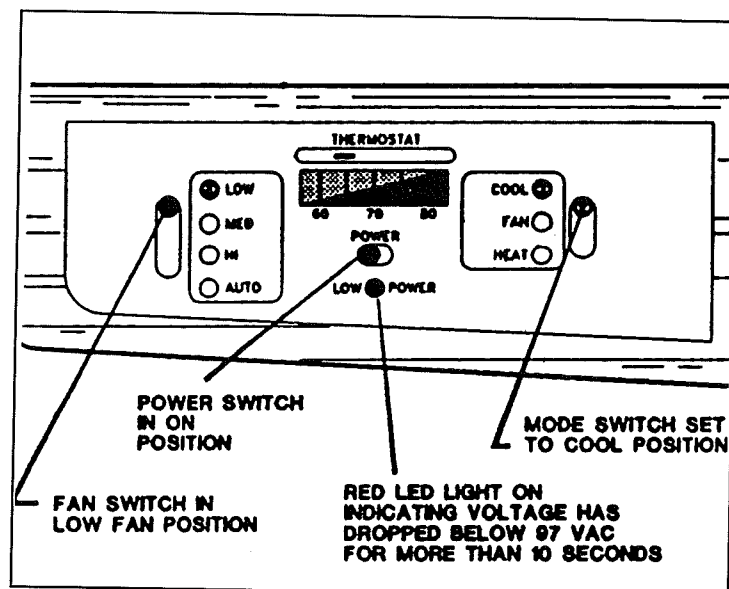

5. **Remote ON/OFF Switch:**

This switch is user supplied and may be installed up to 40 feet from the control. Two screw terminals are located on the back of the control for this connection. The remote switch acts in conjunction with the power switch and when installed acts like a three way switch in your home.

MAINTENANCE

Air Filters: Periodically remove the return air filters. Wash the filters with soap and warm water, let dry and then reinstall or replace as required.

NOTE: Never run the air conditioner without return air filters in place. This may plug the unit evaporator coil with dirt and may substantially affect the performance of the unit.

Frost Formation on Cooling Coil: Under certain conditions frost may form on the evaporator coil. If this should occur, inspect the filter and clean if dirty. Make sure air louvers are not obstructed. Air conditioners have a greater tendency to frost when the outside temperature is relatively low. This may be prevented by adjusting the thermostat slide to a warmer setting. Should frost continue, operate on LOW, MED, or HIGH FAN setting until the cooling coil is free of frost.

SERVICE

If your unit fails to operate or operates improperly, check the following before calling your service center:

- A. If RV is connected to motor generator, check to be sure motor generator is running and producing power.
- B. If RV is connected to power supply by a land line, check to be sure line is sized properly to run air conditioner load and it is plugged into power supply.
- C. Check your fuse or circuit breaker to see if it is open.
- D. In the air conditioner air box, check to be sure the air conditioner conduit is plugged into the junction box and ribbon cable is connected.
- E. After the above checks call your local service center for further help. This unit must be serviced by qualified service personnel only.

When calling for service always give the air conditioner model number and serial number. This information can be found on the unit rating plate located on the air conditioner base pan.

WIRING DIAGRAM

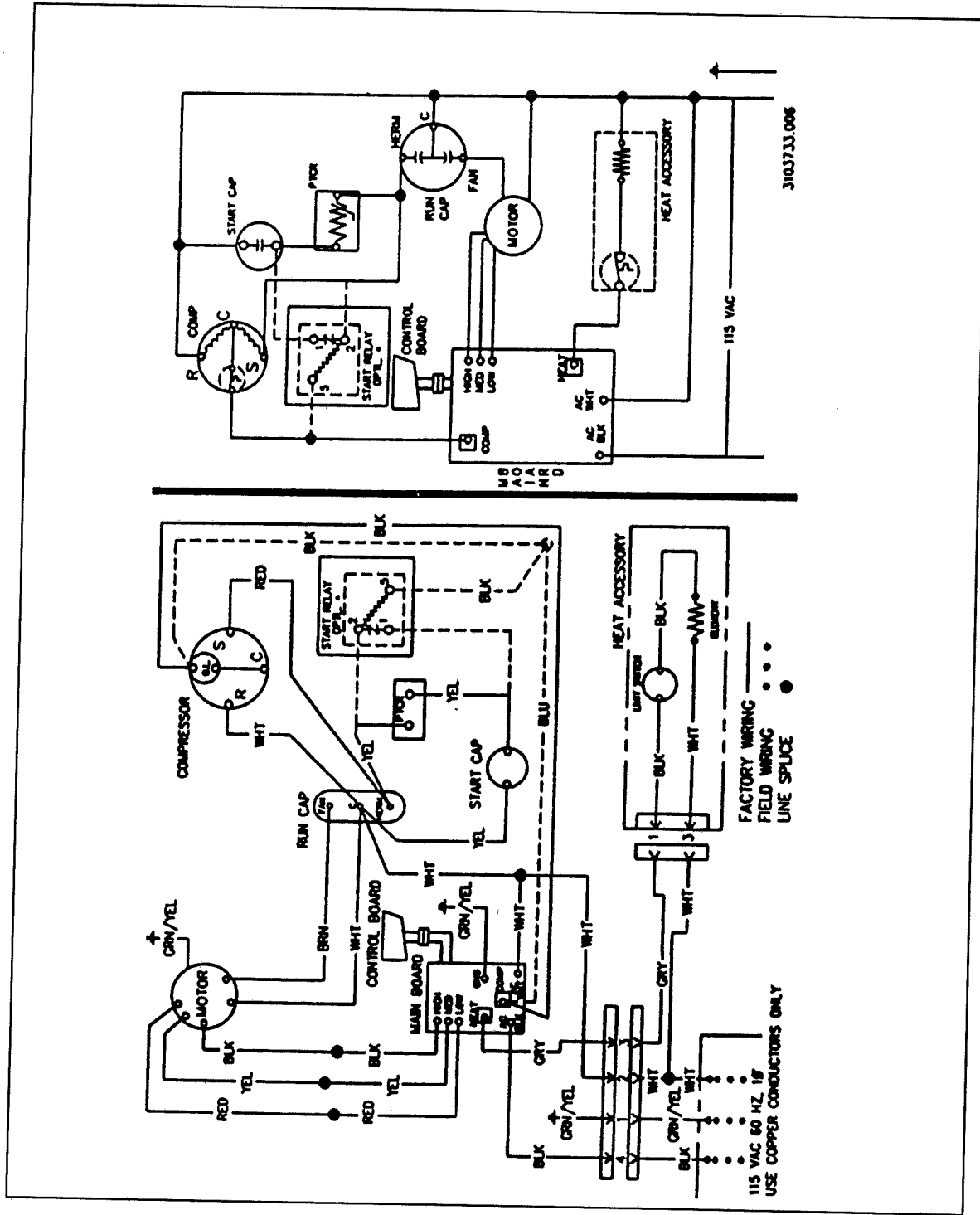

NOTES

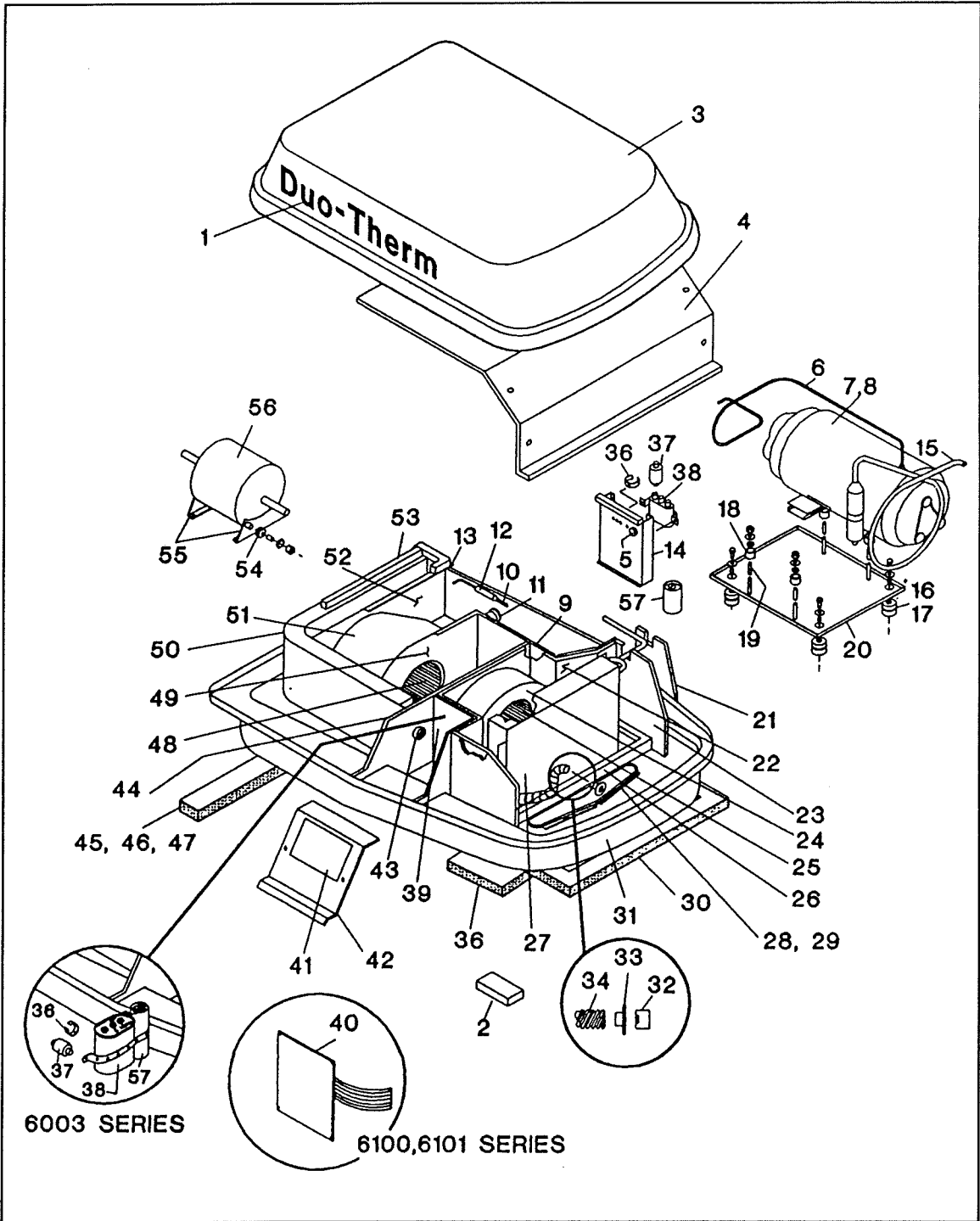

PARTS DESCRIPTION FOR PAGE

- | | | | |
|-----|--|-----|--------------------------------------|
| 1. | Decal, LH (not shown) | 52. | Overload |
| 2. | Decal, RH | 53. | Line, discharge |
| 3. | Shroud | 54. | Grommets, 7 req. |
| 4. | Bracket, PTCR device | 55. | Sleeve |
| 5. | PTCR device | 56. | Plate, compressor |
| 6. | Capacitor fan/run | 57. | Spring |
| 7. | Cover, evap. w/insulation | 58. | Plate, weldment,
compressor mount |
| 8. | Decal | 59. | Line, suction |
| 9. | Panel, Capacitor | | |
| 10. | Bushing, snap in | | |
| 11. | Insulation | | |
| 12. | Capillary tube (2 req) | | |
| 13. | Drier | | |
| 14. | Bulkhead, compressor | | |
| 15. | Plate, close-off | | |
| 16. | Tape, foam | | |
| 17. | Motor | | |
| 18. | Bracket, motor | | |
| 19. | Grommet | | |
| 20. | Blower side, rear | | |
| 21. | Blower scroll | | |
| 22. | Blower side, front | | |
| 23. | Gasket (16 x 1.5") | | |
| 24. | Gasket (16 x 1.5") not shown
Gasket (10 x 1.5") not shown | | |
| 26. | Coil, condenser | | |
| 27. | Wheel, condenser | | |
| 28. | Support, PC board (4 req.) | | |
| 29. | Base pan | | |
| 30. | Bulkhead, evaporator | | |
| 31. | Board, main | | |
| 32. | Decal, wiring | | |
| 33. | Decal, caution | | |
| 34. | Cover, electrical | | |
| 35. | Insulation, blower housing | | |
| 36. | Bulkhead, electrical box | | |
| 37. | Clamp, cable | | |
| 38. | Conduit | | |
| 39. | Anti-short device | | |
| 40. | Plug, male 4 pole | | |
| 41. | Gasket 14 x 14 | | |
| 42. | Insulation, evaporator | | |
| 43. | Plate, evaporator close-off | | |
| 44. | Pan, drain | | |
| 45. | Insulation, Evaporator | | |
| 46. | Blower housing, evaporator | | |
| 47. | Wheel, evaporator | | |
| 48. | Coil, evaporator | | |
| 49. | Bracket, mtg. less nuts (3 req) | | |
| 50. | Nut with clip (3 req) | | |
| 51. | Compressor | | |

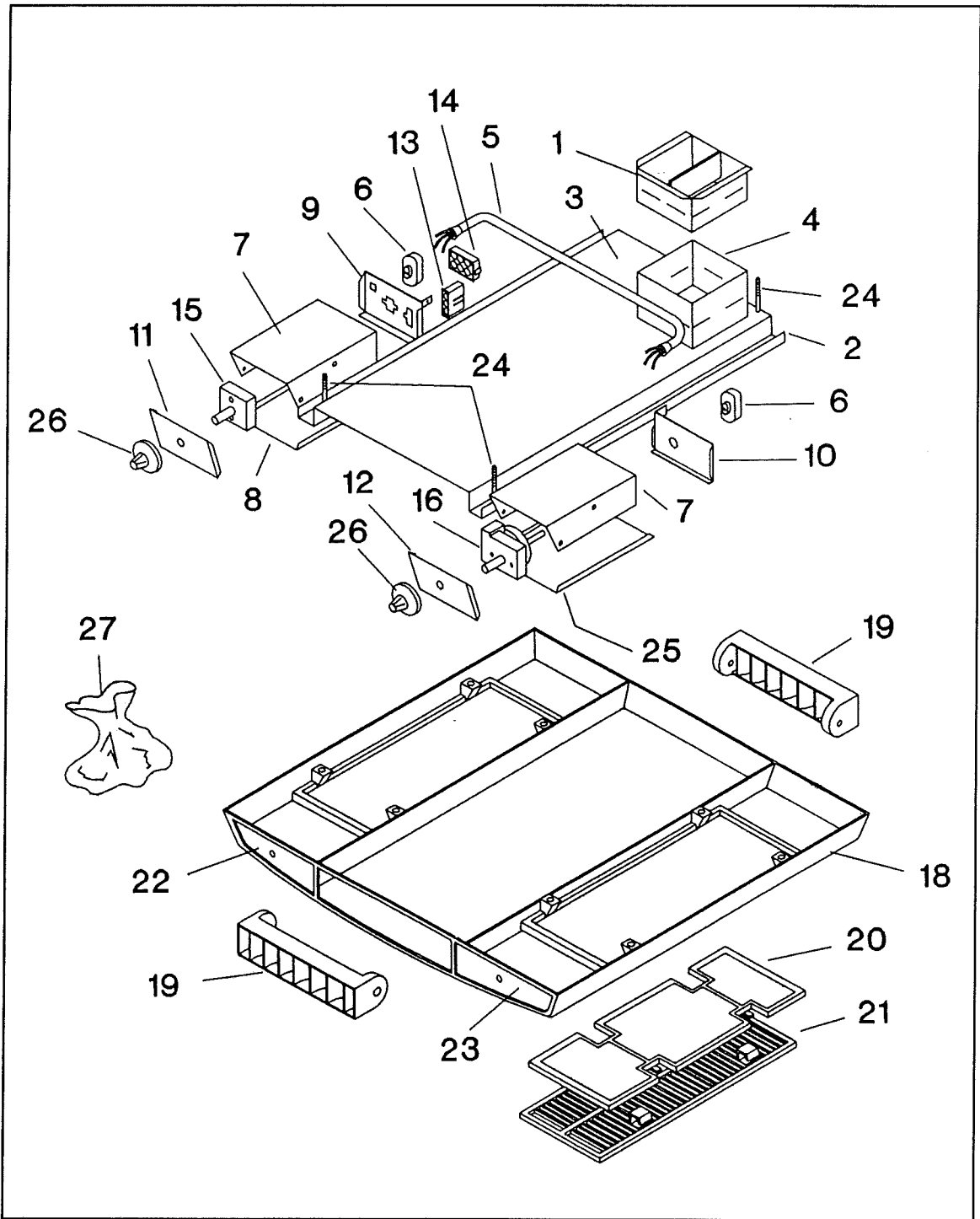

PARTS DESCRIPTION FOR PAGE

Index No.	Description
1-27	Complete parts package asm.
1	Discharge duct, upper
2-17	Complete ceiling template
2	Ceiling template
3	Insulation
4	Discharge duct, lower
5	Conduit
6	Strain relief, 2 req.
7	Junction box
8	Cover, box
9	Box back, LH
10	Box back, RH
11	Box front, LH
12	Box front, RH
13	Plug, female 3-pole
14	Plug, female 9-pole
15	Selector switch, 8-position
16	Thermostat
17	Wiring decal (not shown)
18-23	Complete air box
18	Air box only
19	Louver, 2 req.
20	Air filter, 2 req.
21	Return air grill
22	Decal, left side switch
23	Decal, right side switch
24	Mounting bolt, 3 req.
25	Cover, junction box
26	Knob, selector switch, thermostat
27	Parts bag, small

NOTES

FURNACE

Manufacturer: Hydro Flame Corporation
1874 South Pioneer Road
Salt Lake City, UT 84104
Phone: 801-972-4621

The manufacturer of the furnace in your motorhome has been well known in the RV industry for many years. The furnace burns LP gas, and is powered by 12 volt current from the battery or power converter when plugged into city power. Operating instructions are located in your Owners Packet. If they should become misplaced new literature can be ordered direct from the manufacturer or your Airstream dealer. The manufacturer also offers a detailed service guide for your furnace.

WARNING: Carefully read all the manufacturer's instructions prior to operating. **NEVER** store flammable material next to the furnace.

If warranty service is required use only a service location recommended by the furnace manufacturer or your Airstream dealer.

Lighting Instructions

Read all safety related information before operating the furnace. This appliance is equipped with an ignition device which automatically lights the burner. Do not try to light the burner by hand. This furnace will operate at an elevation of 0 to 10,000 feet.

1. Set the thermostat to the lowest setting or turn the thermostat to the "OFF" position.
2. Wait (5) minutes to clear out any gas. If after 5 minutes you smell gas, **STOP!** Follow the safety information above. If you do not smell gas, go to the next step.
3. Set the thermostat to desired temperature setting and turn the thermostat to the "ON" position. Allow 40 to 60 seconds for the furnace to begin operating. (It may be necessary to set an RV thermostat to a higher setting than that in a home to achieve a comparable level of comfort. Opening an exterior door of an RV results in the rapid loss of interior heat.)

If the furnace does not light, repeat steps 1-3. If the furnace does not ignite after three attempts, turn the thermostat to "OFF" and call a qualified service technician or your gas supplier.

Furnace Components

WARNING: Service and repair procedures in the following text is intended for Qualified Service Personnel use only.

Blower Assembly

The blower assembly is powered by a 12 volt DC motor. Two wheels are used. One for circulating warm air and the other for providing combustion air. See Fig. 1. The blower motor is permanently lubricated and no oiling is required. However, the blower assembly, including blower wheels, should be cleaned every season to remove accumulations of dirt and lint.

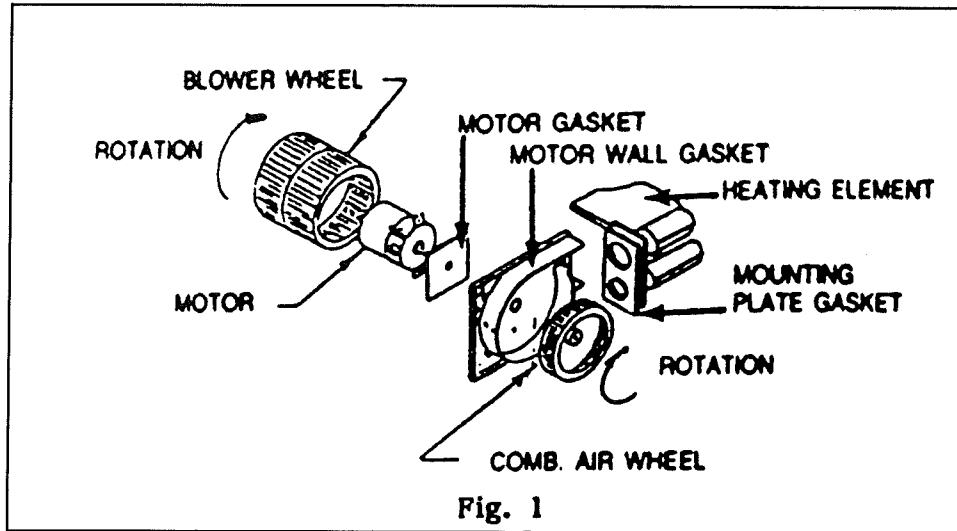

Direct Spark Ignition Circuit Board

The circuit board is located on the back of the electrical panel just behind the front door. As shown in Fig. 2, it operates in conjunction with the ignitor assembly (located at the right side of the control box on the burner box assembly). To provide safe reliable ignition without the use of a standing pilot as described in the "Sequence of Operation" section, the circuit board provides an initial purge cycle of about 20 seconds. During this time only the blower runs so that any unburned gases are purged out of the heat exchanger, prior to ignition.

This purge cycle time is unique to the circuit board used by Hydro Flame and is not the same as most other circuit boards used by other manufacturers. Therefore, it is essential to use only the Hydro Flame Circuit Board if a replacement is required. Hydro Flame circuit board has a protective cover added to the assembly to give added protection from handling and moisture. See Fig. 2.

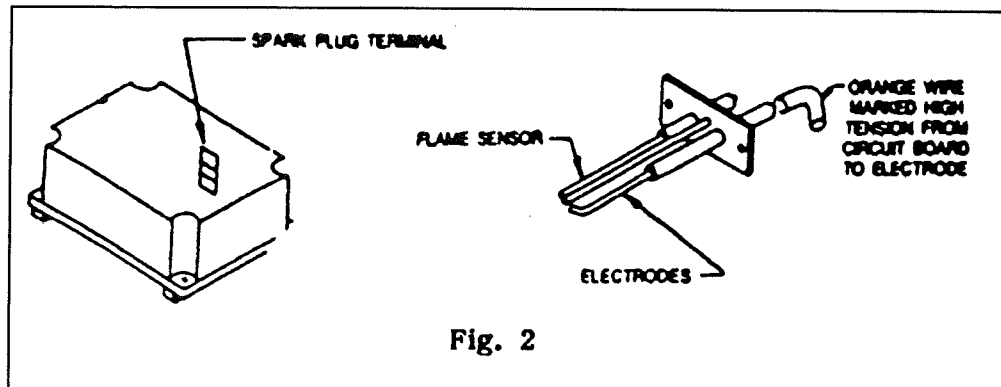

The electrode assembly consists of two electrodes and one flame sensor probe. The spark produced by the circuit board to the electrodes ignites the burner after the purge cycle is completed. The flame sensor probe senses the heat from the burner and signals the circuit board to keep the gas valve open. If ignition does not occur so that the flame sensor does not sense heat, the circuit board will shut the gas valve off within 6 to 9 seconds.

Burner Assembly

To remove the burner assembly from the control box, first remove the draft shield assembly by opening the front door catches and unscrewing the wing nut located on the side of the combustion air housing cover and front screw. See Fig. 3. Next unscrew the manifold from the blower wall and remove the three (3) screws on the burner box.

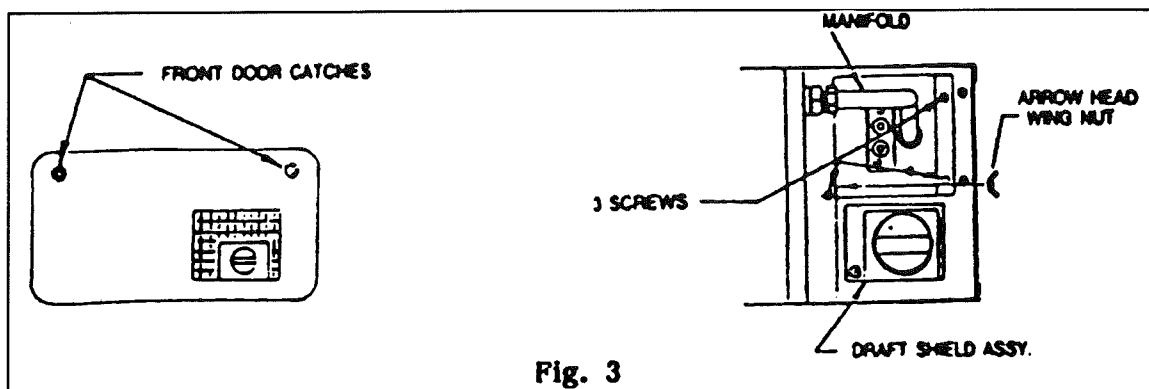

Pull manifold to the right until manifold clears the brass fitting. Now remove burner assembly by pulling the manifold toward you and disconnecting the electrode wires.

CAUTION: When re-installing the burner assembly make sure the two screws on the burner box flange are secure and not stripped.

Air Seal Gaskets

In order to prevent leakage of combustion air from the sealed system, there are gaskets in the following places. These gaskets must be in place and undamaged. See Fig. 4 for gasket locations.

1. Heat exchanger gasket.
2. Motor wall gasket.
3. Motor gasket.

Heat Element Assembly

The heat element assembly can be removed in order to service the exchanger or the heat element gasket. Follow the steps listed:

1. Turn off gas at LP tanks.
2. Disconnect gas line from left side of furnace.

WARNING: Fire or explosion may result when gas line is disconnected at the furnace and the gas bleeds out. Check all appliances which have a pilot still burning and extinguish them or any other flame source in the vicinity.

3. Unplug the electrical plastic disconnect plug from the left side of the furnace.
4. Remove six screws on the left inside of the control box and the two screws on the right inside of the control box. See Fig. 4.

- Remove the twelve screws holding the front door on.

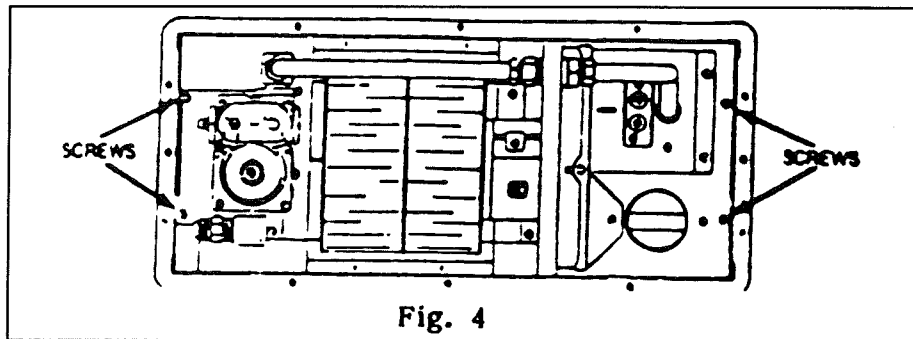

- Pull the entire control box

assembly forward where it can now be serviced and bench tested.

- Remove burner assembly as described earlier and remove three remaining screws holding element assembly to control box.

CAUTION: When re-installing heat element assembly and control box assembly, be sure all screws are firmly in place.

SEQUENCE OF OPERATION

The thermostat controls the operating circuit to the furnace by reacting to room temperature. When room temperature is below the thermostat set point, the contact closes to allow current to flow to the relay.

The circuit breaker limits amperage draw of the motor.

The relay allows current to pass to the motor by closing a switch within the relay. A heater coil within the relay actuates a bimetal disc which closes the relay circuit.

Current flows to the motor to operate the blower. One end of the motor shaft is for the circulating air wheel and the other side is for the combustion air wheel.

Circulating air blows against the sail switch and closes the contacts, completing the circuit. The sail switch is a safety device that insures air flow before ignition.

The limit switch is a safety device that protects the furnace from overheating. The contacts in the limit switch open at a given temperature setting, shutting off power to the direct spark ignition (DSI) system that controls the gas valve.

As power is applied to the DSI board, the system does the following:

- A timing circuit allows the blower to purge the chamber.
- The board supplies current to the gas valve and causes it to open.

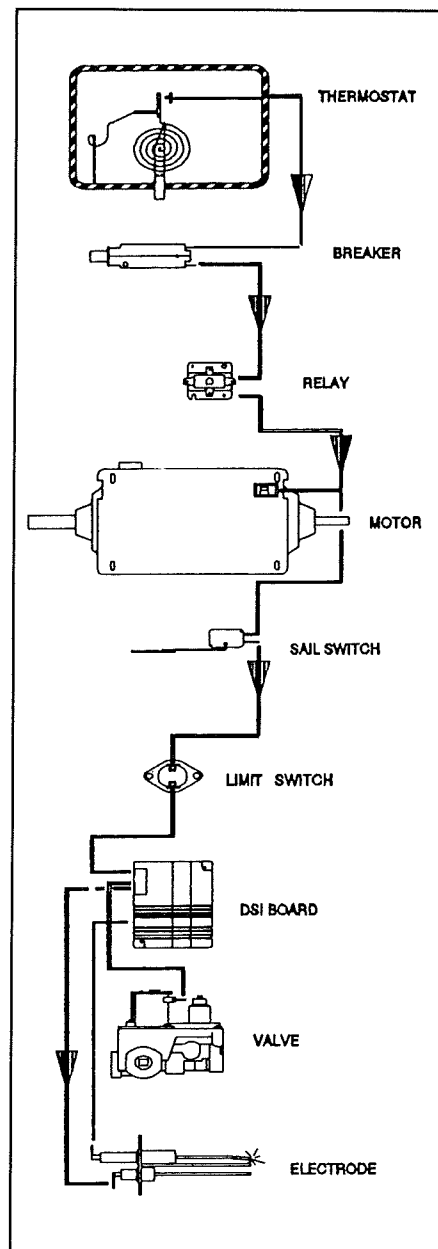

3. As the valve opens, the board sends a high voltage spark to the electrode at the burner. The board confirms the presence of a flame to remain in operation. If the flame is not sensed after 6 seconds, the board will lock out, shutting off power to the valve.
4. If the system does not ignite and the thermostat remains closed, the blower will remain on until the thermostat is reset manually.

When the thermostat senses the desired room air temperature, the contacts open removing power from the ignition system and shutting off the gas valve. The blower runs until the heater coil in the relay cools and opens the circuit, shutting off current to the motor.

PROPANE GAS SYSTEM SAFETY

This furnace is designed to use propane gas only. **DO NOT** attempt to convert to natural gas. The furnace is designed to operate at 11.0 inches Water Column. The measurement should be taken with at least 50 percent of all gas appliances operating in the RV.

WARNING! AN OVERFILLED GAS BOTTLE IS DANGEROUS. GAS BOTTLES SHOULD BE FILLED BY QUALIFIED GAS SUPPLIERS ONLY.

Liquid gas from an overfilled bottle can be forced through the pressure regulator. This high pressure gas could escape and result in a fire or explosion. To prevent this, please read and adhere to the tank manufacturer's operating instructions located on your tank.

SERVICE CHART #1

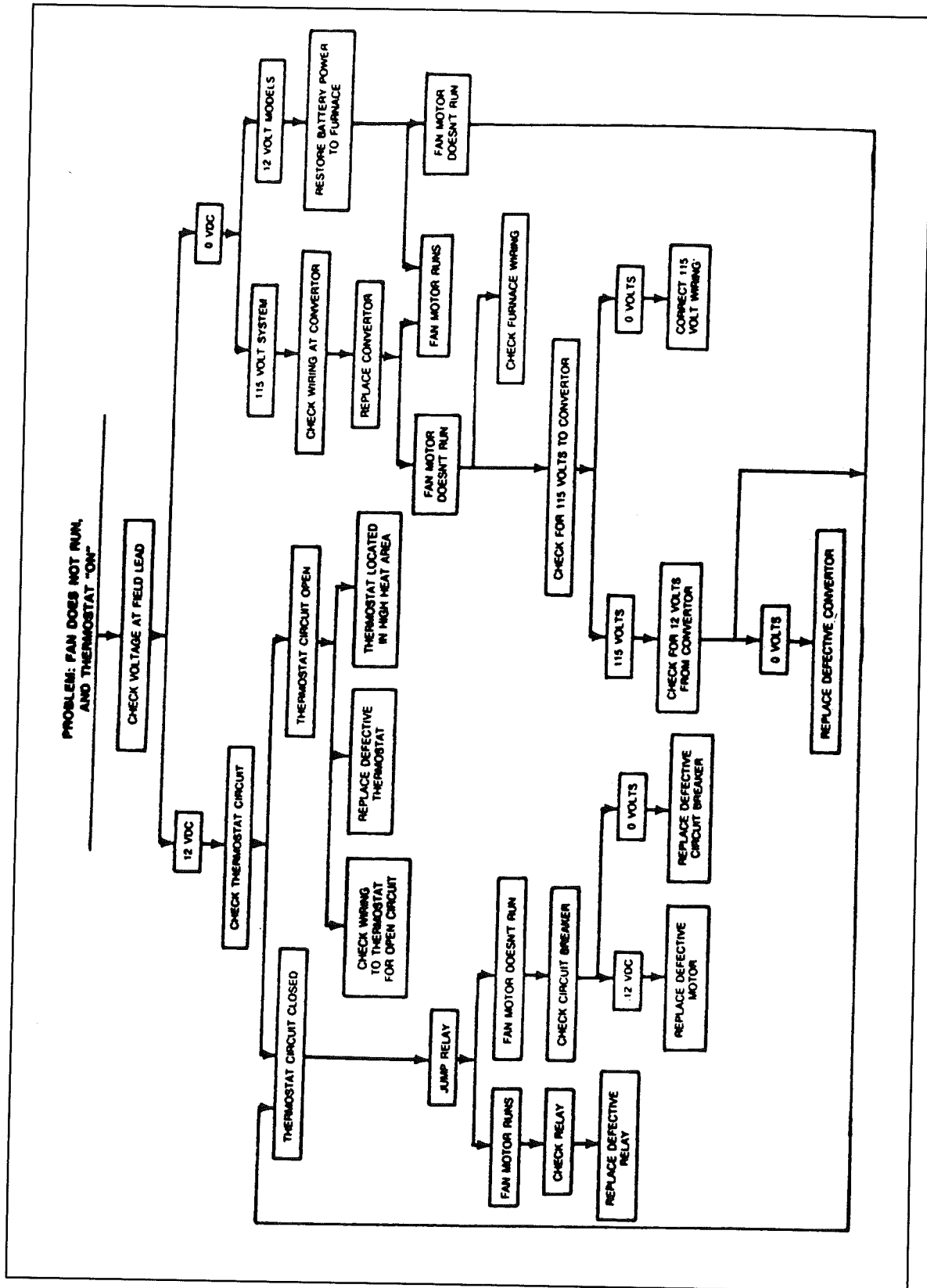

SERVICE CHART #2

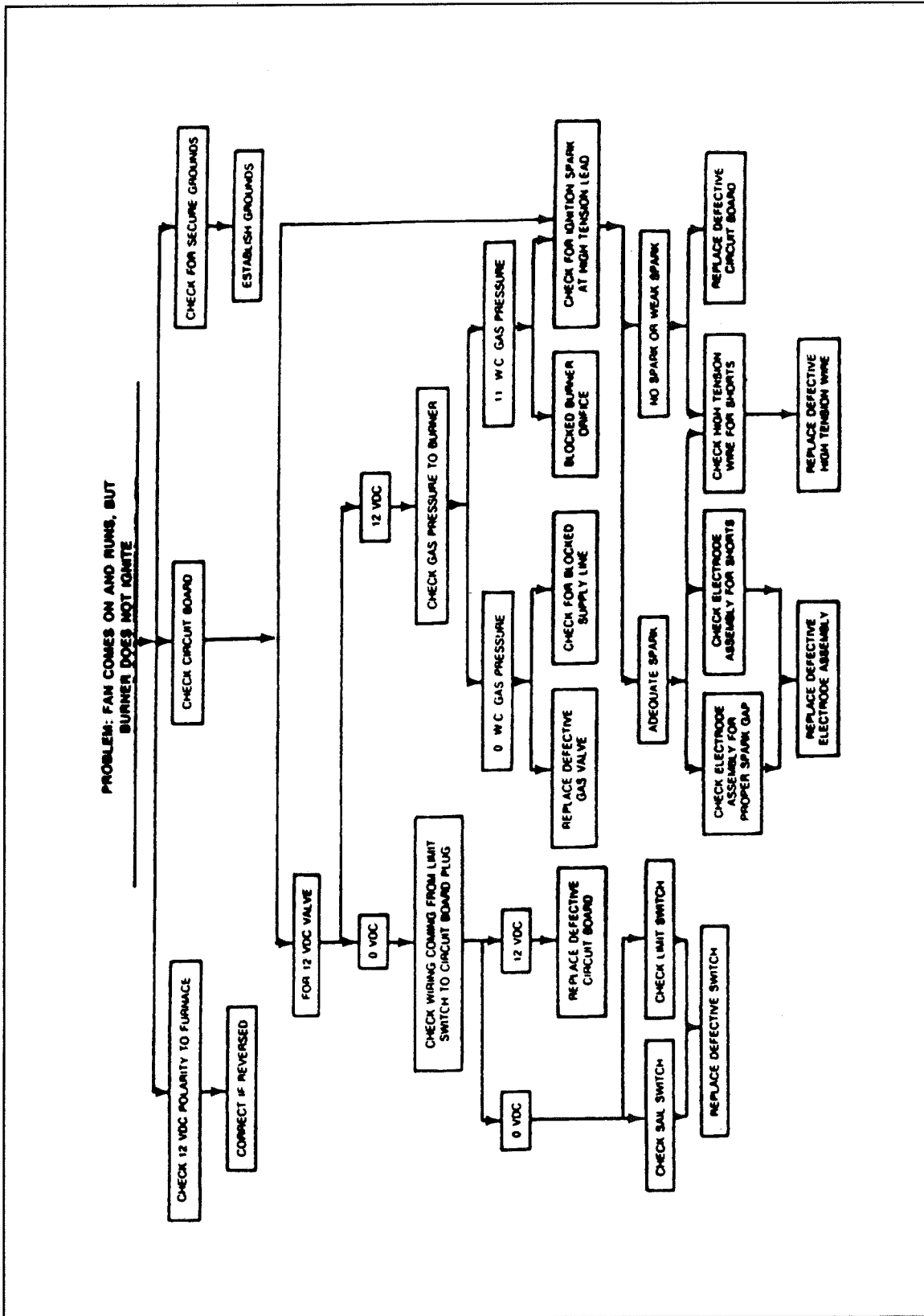

SERVICE CHART #3

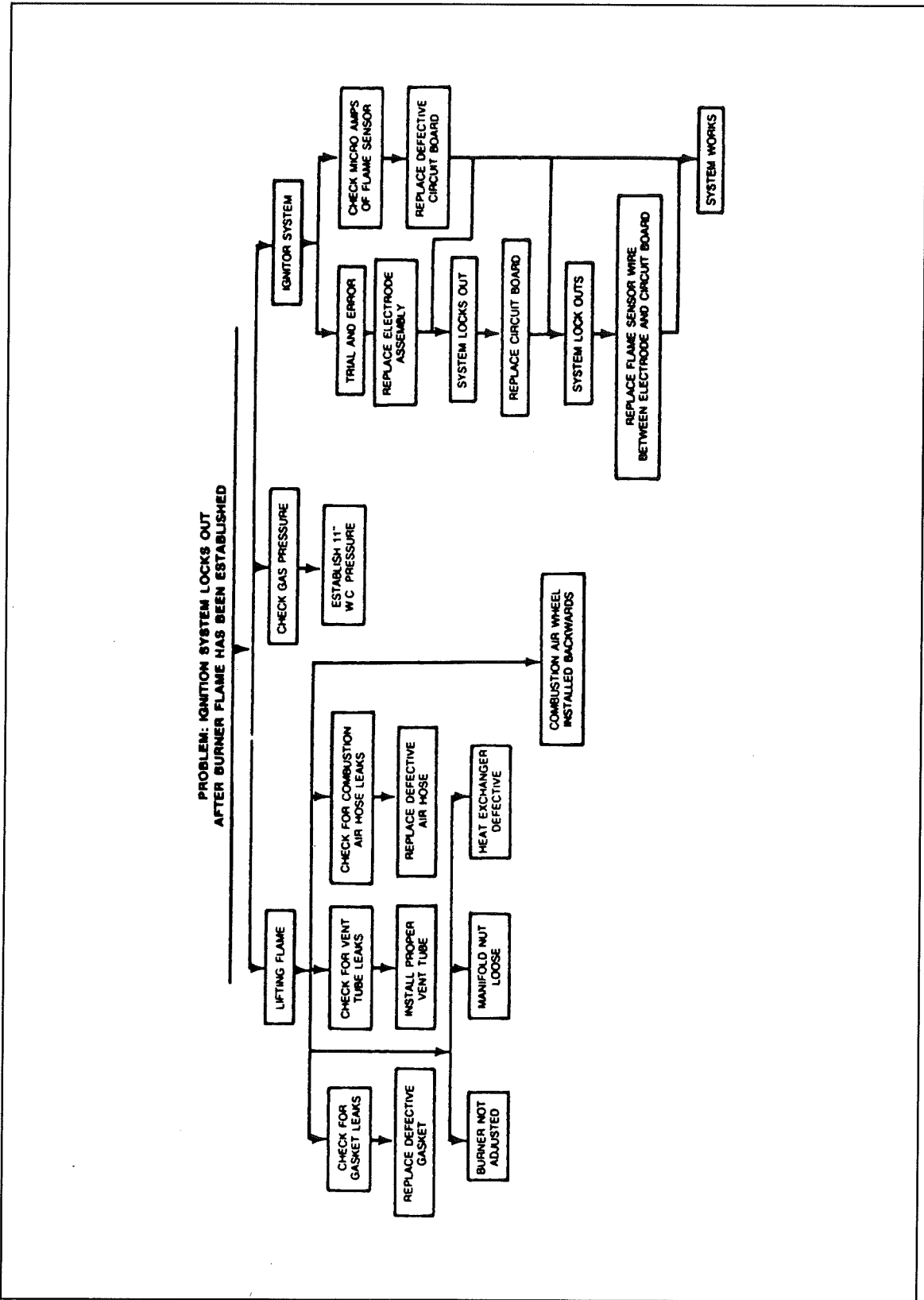

SERVICE CHART #4

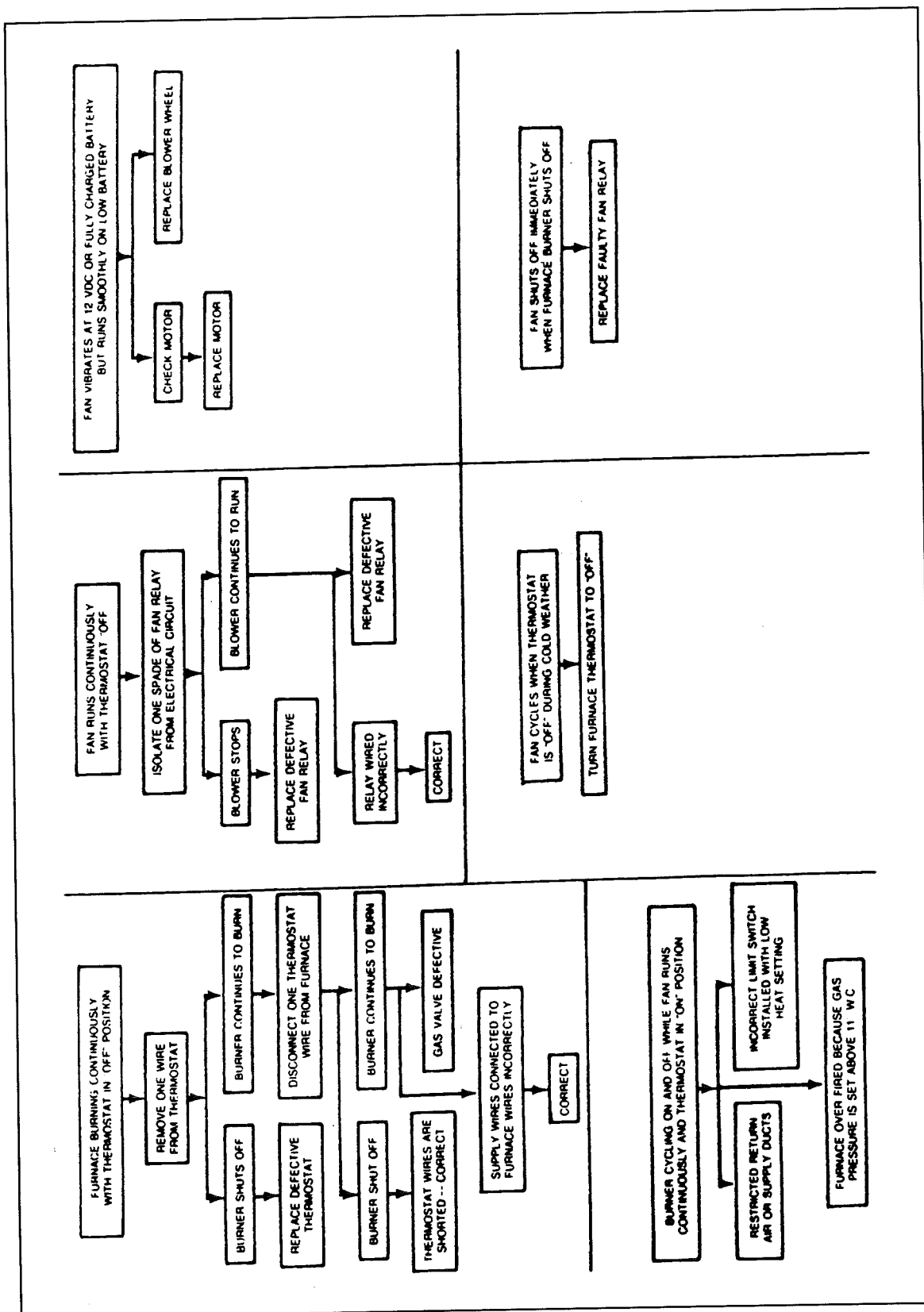

SERVICE CHART #5

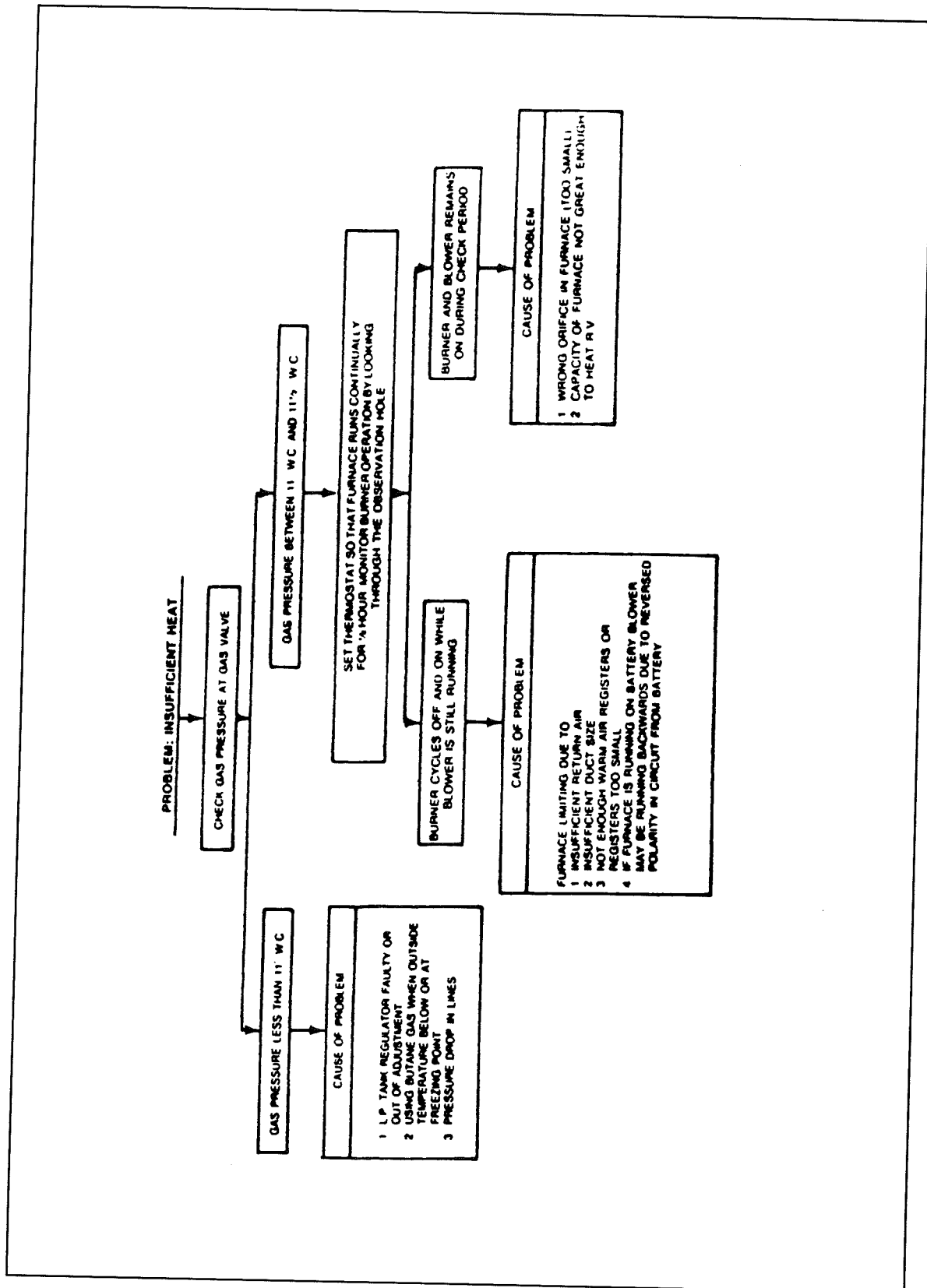

SERVICE CHART #6

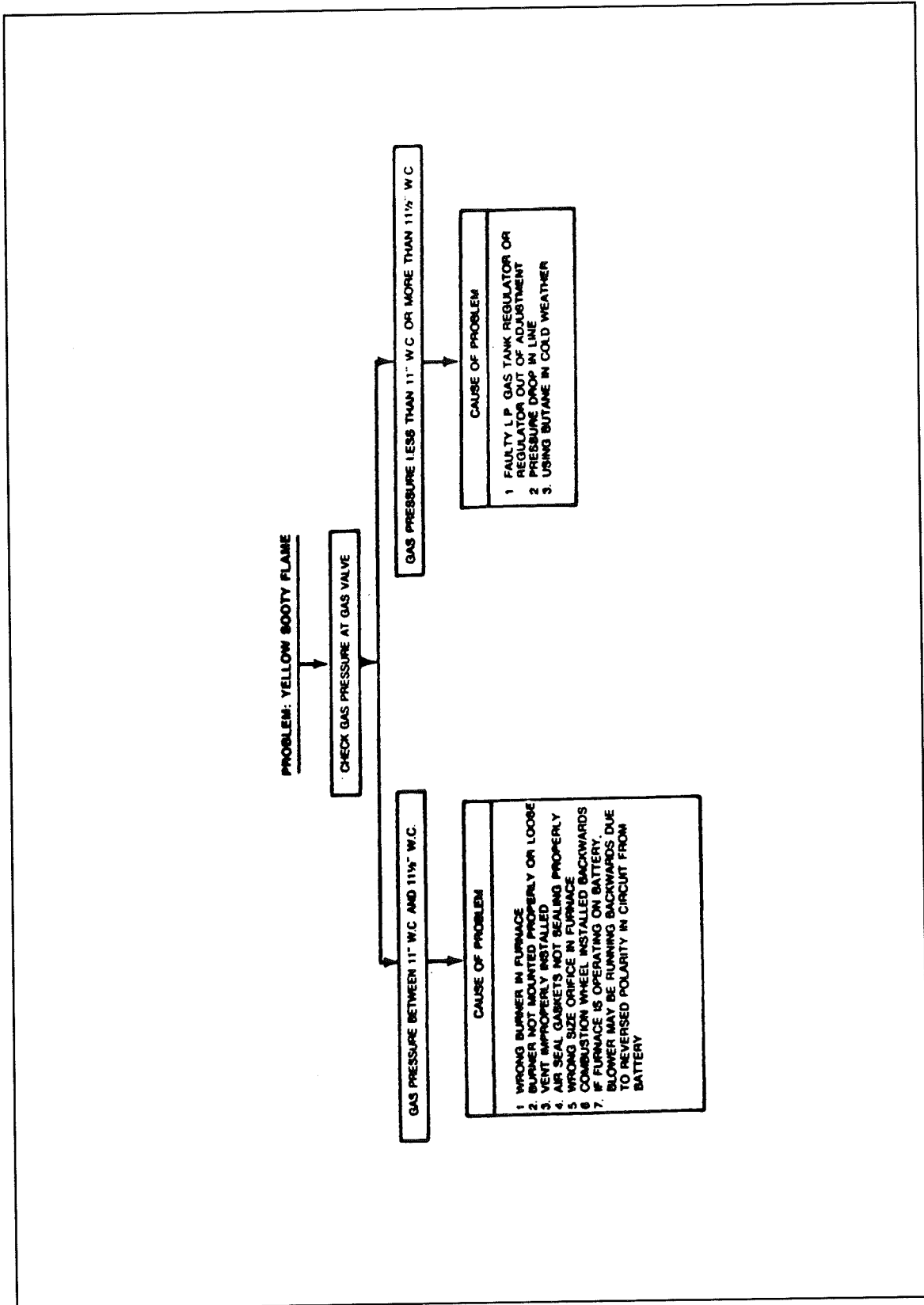

ANNUAL PREVENTIVE MAINTENANCE INSPECTION

The following preventive maintenance and safety checks should be performed by a qualified RV technician once a year, or more, depending on the use of the furnace. **FAILURE TO PROPERLY MAINTAIN THE FURNACE MAY VOID THE FURNACE WARRANTY AND CAN RESULT IN UNSAFE FURNACE OPERATION. PREVENTIVE MAINTENANCE IS NOT COVERED UNDER WARRANTY.**

GAS PRESSURE	Using a U-tube water manometer, with the furnace and at least 50 percent of the appliances operating, the pressure should be 11 inches W.C. Improper gas pressure can cause the furnace to work inconsistently and create unbalanced combustion.
VOLTAGE	There should be between 10 and 13.5 VDC at the furnace during operation. This check should be made from the battery, converter and generator when applicable. Low voltage can cause the furnace to overheat and cycle. High voltage can cause unbalanced combustion, and excessive motor wear.
DUCTING	The heat ducts should be clean and clear of obstructions. Check that the ducts are properly connected and have not come loose from the furnace or outlets.
RETURN AIR	The return air passage should be clean and clear of obstructions and meet the minimum square inches as specified in the installation instructions. <i>Make sure combustibles are not stored in the furnace compartment.</i>
COMBUSTION CHAMBER	Check the chamber for internal obstructions such as wasp or bird nests. The life of the combustion chamber is a function of the amount of time that the furnace has operated. Therefore, it is essential to inspect the chamber for cracks and holes. Have the chamber replaced if it has any cracks or holes - this condition is not field repairable.
GASKETS	Inspect all gaskets for tight seals. <i>Do not reuse gaskets - always replace with new.</i> Worn seals may allow carbon monoxide to enter the living area and cause illness or death.
GAS SUPPLY SYSTEM	Perform a pressure-drop test according to current ANSI standards, to insure there are no gas leaks.
AIR WHEEL	The air wheel should be clean and clear of obstructions. Starting the furnace with something in the blower will damage the wheel, making replacement necessary.
WIRE CONNECTIONS	Check the furnace for loose or disconnected wires.
DOOR SCREEN	Check the door screen for damage or clogged openings. See door installation section for proper installation of door assembly. Clean with warm soapy water.
CONTROL COMPARTMENT	Clean the control compartment.
MOTOR	The motor is lubricated and permanently sealed. It requires no oiling.

NOTES

FURNACE PARTS LIST 89 MODELS SERIES DC AND AC

Parts Drawing No.	Description
1	Blower wheel
2	Blower housing cover
3	Blower housing assembly
4	Gasket bottom discharge
5	Burner box assembly
6	Burner assembly
7	Extension box kit
8	Circuit breaker
9	Coil replacement
10	Combusion wheel
11	Control box assembly
12	Door hinge (2)
13	Door assembly (specify color)
14	Slide plate
15	Thermostat
16	Valve bracket
17	Valve
18	Wiring harness assembly complete
19	Draft cap assembly
20	DSI board (05-30)
20	DSI board (05-15)
21	DSI bracket
22	Duct adapters
23	Duct cover plate
24	Electrode
25	Electrode gasket
26	Flex adapter plate
27	Gas inlet plug
28	High tension lead
29	Inlet manifold
30	Bottom plenum plate kit
31	Inner door
32	Limit switch
33	Motor bracket
34	Motor mounting wall assembly
35	Motor gasket
36	Motor
37	Orifice
38	Outer door fastener (2)
39	Outlet manifold
40	Relay
41	Sail switch
42	Element assembly
43	Exhaust wall gsket
44	Female street elbow, 3/8 x 3/8
45	Recess pan assembly (specify color)

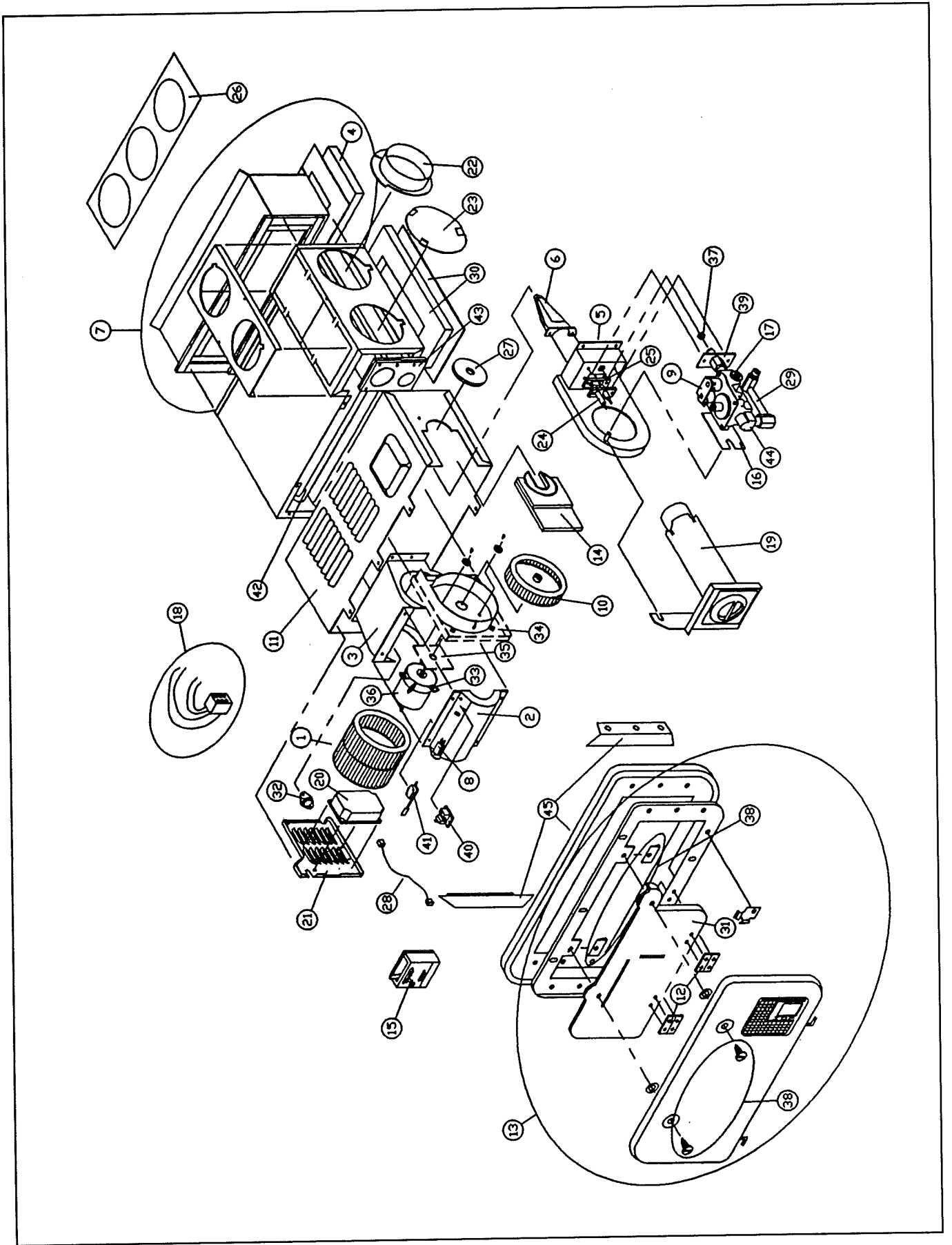

NOTES

REFRIGERATOR

Manufacturer: The Dometic Corporation
509 South Poplar St.
LaGrange, IN 46761
Phone: 219-463-4850

ROYAL, 3-WAY

INSTRUCTIONS FOR USE

HOW TO START THE REFRIGERATOR

In an absorption refrigerator system, ammonia is liquefied in the finned condenser coil at the top rear of the refrigerator. The liquid ammonia then flows into the evaporator (inside the freezer section) and is exposed to a circulating flow of hydrogen gas, which causes the ammonia to evaporate, creating a cold condition in the freezer.

The tubing in the evaporator section is specifically sloped to provide a continuous movement of liquid ammonia, flowing downward by gravity, through this section. If the refrigerator is operated when it is not level and the vehicle is not moving, liquid ammonia will accumulate in sections of the evaporator tubing. This will slow the circulation of hydrogen and ammonia gas, or in severe cases, completely block it, resulting in a loss of cooling.

Any time the vehicle is parked for several hours with the refrigerator operating, the vehicle should be leveled to prevent this loss of cooling. The vehicle needs to be leveled only so it is comfortable to live in (no noticeable sloping of floor or walls).

When the vehicle is moving the leveling is not critical, as the rolling and pitching movement of the vehicle will pass to either side of level - keeping the liquid ammonia from accumulating in the evaporator tubing.

OPERATION

Before starting the refrigerator check the gas valve in the piping. Do not forget the valve on the rear of the refrigerator, see FIG. 1.

This refrigerator is equipped with an Automatic Energy Selector (AES) control system, which can automatically select the most suitable energy source which is available, either 120 Volt AC, DC or LP gas operation. The system can be set by the user to be fully automatic between all sources or automatic selection between 120 Volt AC and LP gas operation, or if desired, LP gas only. The refrigerator controls will work down to 9.6 volt DC.

WARNING: Most LP gas appliances used in recreational vehicles are vented to the outside of the vehicle. When parked close to a gasoline pump, it is possible that gasoline fumes could enter this type of appliance and ignite the burner flame, CAUSING A FIRE OR AN EXPLOSION.

FOR YOUR SAFETY, it is recommended that all LP gas appliances which are vented to the outside should be shut off when refueling.

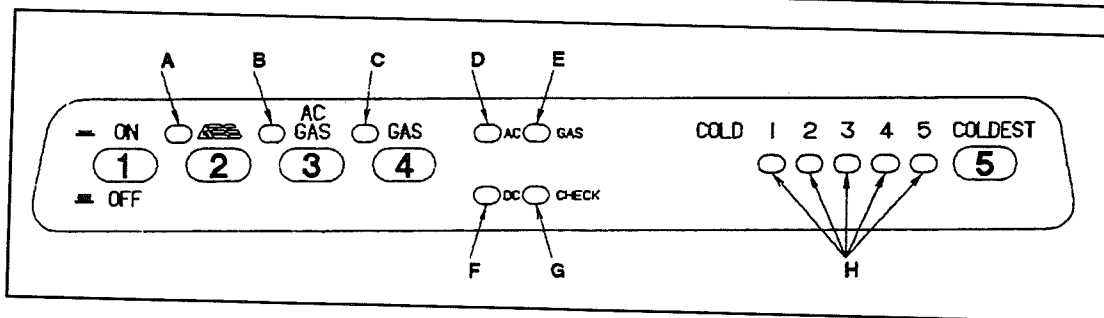
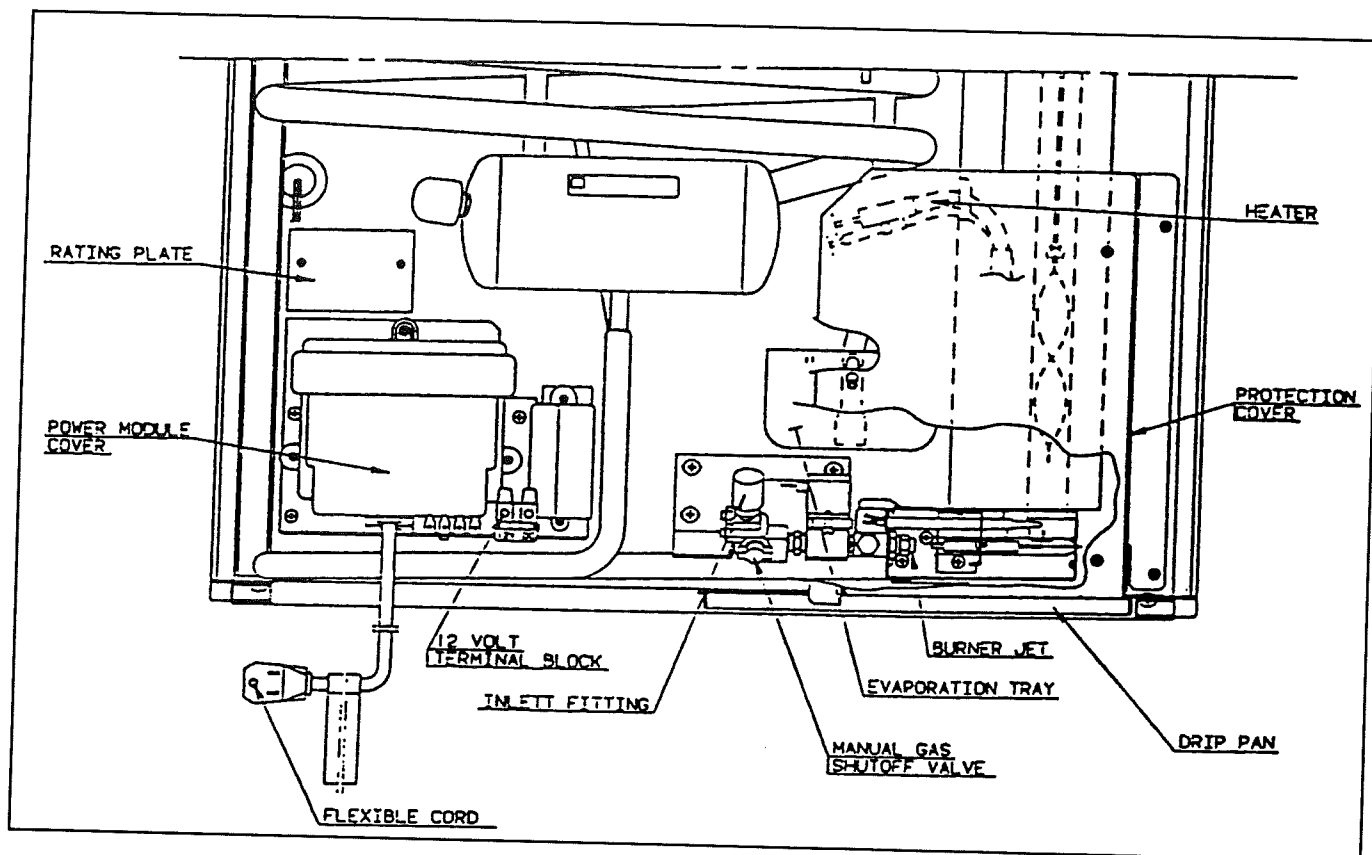

LEGEND 3-WAY AES Model

1. Main Power Button ON/OFF
 2. AES Mode Selector Button
 3. AC/GAS Mode Selector Button
 4. Gas Mode Selector Button
 5. Temperature Selector Button
-
- A. AES Mode Indicator Lamp
 - B. AC/GAS Mode Indicator Lamp
 - C. GAS Mode Indicator Lamp
 - D. AC Energy Mode Indicator Lamp
 - E. GAS Energy Mode Indicator Lamp
 - F. DC Energy Mode Indicator Lamp
 - G. CHECK Indicator Lamp
 - H. Temperature Indicator Lamps

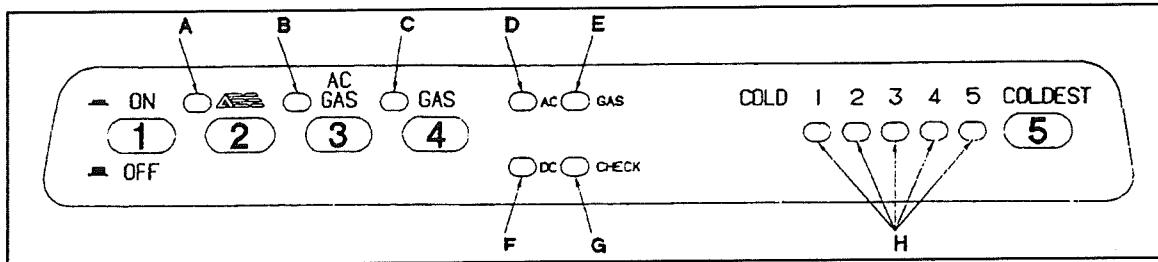

3 - WAY AES display panel.

START UP INSTRUCTIONS

- A. A 12 volt DC supply must be available for the electronic control to function.
- B. Press the main power ON/Off button (1) to the DOWN position.
- C. Press the TEMPERATURE SELECTOR BUTTON (5) until the lamp at the desired setting is illuminated.

AES MODE

1. Press the AES mode selector button (2) to the DOWN position. Indicator lamp (A) should illuminate. Indicator lamp (D), (E) or (F) should also illuminate indicating which energy source the control has selected.
2. Press the TEMPERATURE SELECTOR button (5) until the lamp at the desired position is illuminated.

AC/GAS MODE

1. The AES mode selector button (2) must be in the UP (off) position.
2. Press the AC/GAS mode selector button (3) to the DOWN (on) position. Mode indicator lamp (B) should illuminate. Indicator lamp (D) or (E) should also illuminate indicating which energy source the control has selected. If the CHECK indicator lamp (G) illuminates, see GAS MODE for further instructions.
3. Press the TEMPERATURE SELECTOR button (5) until the lamp at the desired position is illuminated.

GAS MODE

1. The AES (2) and AC/GAS (3) mode selector buttons must be in the UP (off) position.
2. Press the GAS mode indicator button (4) to the DOWN (on) position. Indicator lamps (C) and (E) should illuminate indicating GAS operation. After 45 seconds the burner should be ignited and operating normally.
3. On the initial refrigerator start-up, it may take longer than 45 seconds to allow air to be purged from the gas line. If the gas does not ignite within 45 seconds the CHECK indicator lamp (G) will illuminate and the GAS indicator lamp (E) will go off. To reset when the CHECK indicator lamp (G) is illuminated, press the main power ON/OFF button (1) to the OFF and then ON position.

NOTE: Do not continue to reset GAS operation if the CHECK indicator lamp continues to be illuminated after several tries.

4. Press the TEMPERATURE SELECTOR button (5) until the lamp at the desired position is illuminated.

3 - WAY AES display panel.

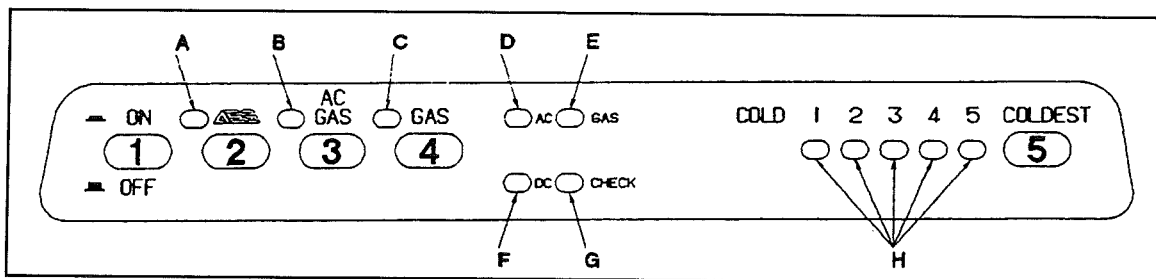

DESCRIPTION OF OPERATION MODES

Thermostat

The thermostat on the refrigerator controls both the gas and electric operation, thereby eliminating the necessity of resetting each time a different energy source is employed.

After the initial start-up, the thermostat should be moved from "COLDEST" to the desired temperature setting, usually about mid setting.

AES MODE

The AES mode of operation takes priority over all other operating modes. If more than one mode selector button (2), (3) or (4) is in the down position the priority is from left to right. When operating in the AES mode, the AES mode indicator lamp (A) will illuminate. In this mode the control system will automatically select the energy source with AC having top priority, DC second priority and GAS third priority. If the control system has selected a particular energy source such as AC, and then it becomes unavailable, it will automatically seek out the next available energy source.

AC/GAS MODE

When operating in the AC/GAS mode the AC/GAS mode indicator lamp (B) will illuminate. In this mode of operation the control system will automatically select between the AC and GAS energy sources with AC having first priority.

GAS MODE

When operating in the GAS mode the GAS mode indicator lamp (E) will illuminate. The GAS mode provides LP gas operation only. The control system will activate the ignition system and will attempt to light the burner for a period of approximately 45 seconds. If unsuccessful, the CHECK indicator lamp (G) will illuminate and the GAS mode indicator lamp (C) will turn off.

To restart GAS operation, press the main power ON/OFF button (1) to the OFF and then ON position. The control system will attempt a new 45 seconds ignition sequence.

If the refrigerator has not been used for a long time or the LP tanks have just been refilled, air may be trapped in the supply lines. To purge the air from the lines may require resetting the main power ON/OFF button (1) three or four times. If repeated attempts fail to start the LP gas operation, check to make sure that the LP gas supply tanks are not empty and all manual shutoff valves in the lines are open. If the problem is still not corrected, contact a service center for assistance.

If the control is switched to the AES or AC/GAS mode of operation while the CHECK indicator lamp is on, it will function properly, but the CHECK indicator lamp will not go off until the main power ON/OFF button is pressed to the OFF then ON position.

BATTERY PROTECTION SYSTEM

The control system is equipped with a battery protection system. If AC power is not available the control will switch to the DC energy source. If the input voltage at the terminal block connections is below 12.8 volts the control system will bypass the DC energy source and attempt GAS operation. If the GAS energy source is available, CHECK lamp is on, the control system will return to the DC energy source. The control will operate in the DC mode for a maximum of 10 minutes.

If the input voltage has not returned above 12.8 volts within this time, the control will terminate DC operation and turn off the DC lamp (F) and start gas operation if GAS energy source is available.

The input battery voltage must be above 12.8 volts for 25 minutes before DC operation can resume.

As soon as the input voltage rises above the required 12.8 volts, the DC mode lamp (F) will illuminate. However the control system will remain in the 25 minute DC delay mode and operate on gas. This delay is to allow sufficient time for the vehicle charging system to recharge the battery. If 120 volt AC becomes available during the 25 minute delay, the control will automatically switch energy source.

LIMP MODE OF OPERATION

This control system contains a feature where it will continue to operate the cooling system in the event of a failure of a major operating component. Two different modes of operation can occur in this category.

If for some reason the display module becomes non functional, the control system will revert to full automatic operation selecting the best energy source available with AC, DC and GAS priority. The temperature of the refrigerator will be maintained at the MID position within normal temperature tolerances.

The power module will continually attempt to re-establish operation of the display module.

The second limp mode of operation will execute when a failure of the temperature sensing device or associated electronic circuitry occurs. If this should occur, the control system will operate on the energy source selected via the control panel. The cooling unit will run continuously on the selected energy source. The refrigerator will continue to operate in this mode indefinitely or until a new sensor is installed and the system is reset.

HOW TO USE THE REFRIGERATOR

Food Storage Compartment

The food storage compartment is completely closed and unventilated, which is necessary to maintain the required low temperature for food storage. Consequently, foods having a strong odor or those that absorb odors easily should be covered. Vegetables, salads etc., should be covered to retain their crispness. The coldest positions in the refrigerator are under the cooling fins and at the bottom of the refrigerator. The warmer areas are on the upper door shelves. This should be considered when placing different types of food in the refrigerator.

Frozen Food Storage Compartment

Quick frozen soft fruits and ice cream should be placed in the coldest part of the compartment which is on or just below the freezer shelf. Frozen vegetables may be stored in any part of the compartment.

This compartment is not designed for deep or quick freezing of food. Meat or fish, whether raw or prepared, can be stored in the frozen food storage compartment provided they are pre-cooled first in the refrigerator. They can be stored about three times longer in the frozen food compartment as compared to the fresh food compartment. To prevent food from drying out, keep it in covered dishes containers, plastic bags or wrapped in aluminum foil.

Ice Making

Ice cubes can be made in the ice tray placed in the freezer compartment. The tray should be filled with water to within 1/4" (1mm) from the top. For faster ice making, the tray should be placed in direct contact with the freezer shelf.

To release the ice cubes, seize the tray with both hands and twist the tray. Cubes not required should be replaced in the tray. Refill the tray with water and replace the tray on the freezer shelf.

Ice will be made more rapidly if the thermostat is set at its highest position.

It is a good idea to do this a few hours before the anticipated need for ice, but be sure to move back to normal setting, usually about mid setting when the ice is formed. Food in the lower compartment may be frozen if the setting is left on "COLDEST" position.

Defrosting

Shut off the refrigerator by pressing the main power ON/OFF button to the UP (OFF) position. Empty the refrigerator, leaving the drip tray under the finned evaporator, and the cabinet and freezer doors open. Defrosting time can be reduced by filling the ice tray with hot water and placing it on the freezer shelf.

CAUTION: DO NOT use a hot air blower. Permanent damage could result from warping the metal or plastic parts. DO NOT use a knife or an ice pick, or other sharp tools to remove frost from the freezer shelf. They can create a leak in the ammonia system.

When all frost is melted, dry the interior of the refrigerator with a clean cloth. REplace all food and set thermostat to the COLDEST temperature setting for a few hours. Then reset the thermostat to the desired setting, usually at mid setting.

NOTE: On these models the drip tray/cup is on the rear side of the refrigerator. (see Fig. 1)

Move the plastic drain tube in to a water tight bucket or container. (Access through louvered service panel on the outside of the vehicle.) As the frost melts, the water will flow into the container. When all the frost has melted wipe up the excess moisture and empty the accumulated water from the bucket. Replace the drain tube to its original position.

Cleaning

Cleaning the refrigerator is usually done after it is defrosted or put into storage. To clean the interior liner of the refrigerator, use lukewarm weak soda solution. Use only warm water to clean the finned evaporator, ice trays and shelves. NEVER use strong chemicals or abrasives to clean these parts as the protective surfaces will be damaged. It is important to always keep the refrigerator clean.

Shut Off - Storage Procedure

Shut off the refrigerator by pressing the main power ON/OFF button to the UP (OFF) position.

If the refrigerator will not be in operation for a period of weeks, it should be emptied, defrosted, cleaned and the doors left ajar. The ice tray should also be dried and kept outside the cabinet.

The handle of the travel latch is designed to keep the refrigerator doors open slightly allowing air to circulate, preventing odors and mildew. The doors can be secured in the vented position by pushing the square button "A" (Fig. 9) until the notch seizes the catch "B" (Fig. 9). To release the door, simply pull the handle.

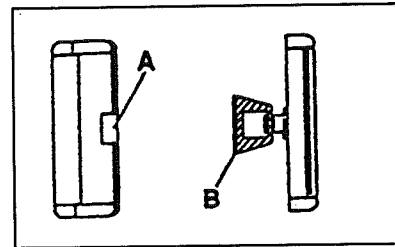

Figure 9

CAUTION: DO NOT store explosive substances in the refrigerator, such as cigarette lighter gas, petrol, ether or the like.

GAS EQUIPMENT ASSEMBLY

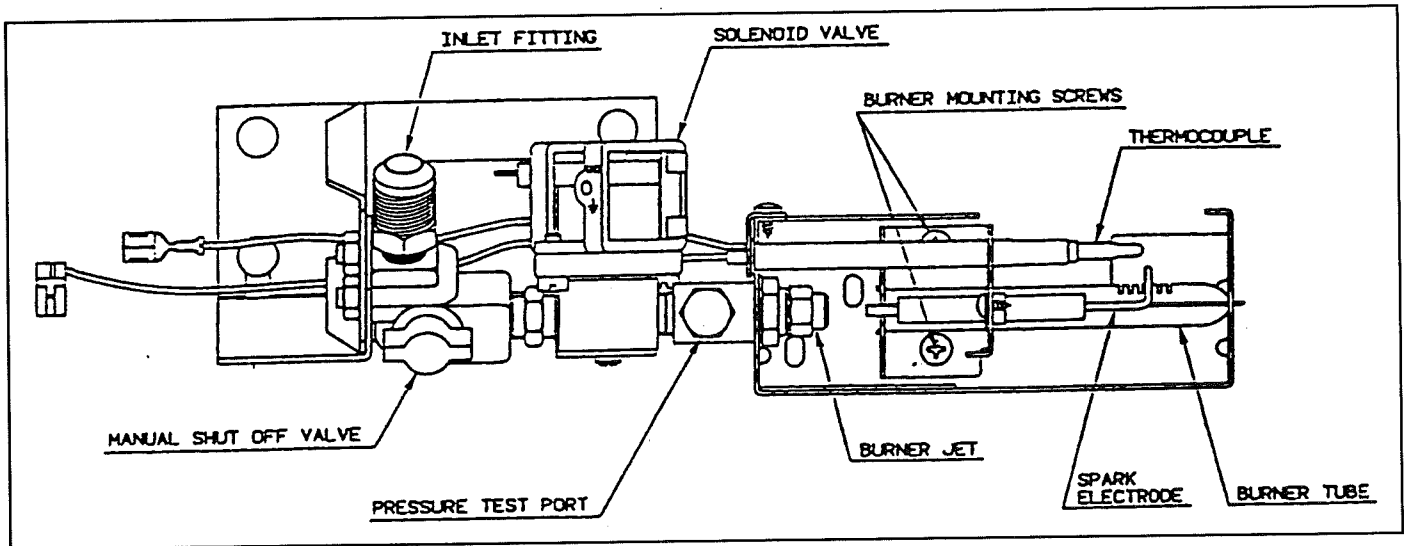

Figure 10

ELECTRIC EQUIPMENT

Cartridge Heater

The heat necessary for the operation of an absorption cooling unit is supplied by an electric heater mounted in a pocket of the boiler system.

The 3-WAY model is equipped with two electrical heaters, one for 120 volt AC and one for 12 DC volt.

To replace the heater proceed as follows:

1. Disconnect the wall plug, and the 12 volt wires.
2. Remove the protection cover see Fig. 1.
3. Remove the power module cover see Fig. 1.
4. Disconnect the heater leads.
5. With a pair of pliers unfold the lug holding the lid of the boiler casing and open the lid.
6. Remove some insulation wool so that the heater is accessible.
7. Turn and lift the heater out of its pocket.
8. Fit the new heater into the pocket.
9. Connect the leads and put on the power module cover.
10. Reset the insulation and close the lid of the boiler.
11. Replace the protection cover.

FUSES

These models are equipped with 3 fuses, one for the refrigerator control system and one for both the AC and DC cartridge heater. (see table below)

To replace fuses proceed as follows.

1. Disconnect the wall plug, and the 12 volt wires.
2. Remove the power module cover. See FIG. 1.
3. Snap the fuse out of the fuse holder.
4. Fit a new fuse in to the fuse holder.
5. Replace the power module cover.

Control system	3 Amp
AC heater	5 Amp
DC heater	35 Amp

MAINTENANCE & SERVICE

1. Refrigerator Removal

Before working on the refrigerator make sure that 120 volt AC and 12 volt DC leads are disconnected. Close the shutoff valve on the gas supply piping system. Disconnect the outgoing gas line from the gas valve at the rear of the refrigerator. (see Fig. 1.)

Loosen the screws anchoring the refrigerator to the enclosure (see Fig. 5) and slide the refrigerator forward out of the compartment.

When replacing the refrigerator make sure that the sealing strips are properly positioned.

After reassemble the gas connection should be checked for leaks.

2. Periodic Maintenance

To keep your Dometic refrigerator operating efficiently and safely, periodic inspection and cleaning of several components once or twice a year is recommended.

- A. It is important to keep the area at the back of the refrigerator clean. Check the lower vent, upper vent and area between these openings for any obstructions such as bird/insect nests, spider webs, etc.

Clean the coils on the back of the refrigerator. Use a soft bristled brush to dust off the coils. It is important to keep the refrigerator area free form combustible material, gasoline and other flammable vapors or liquids.

NOTE: AVOID SPRAYING WATER THROUGH THE REFRIGERATOR VENTS WHILE WASHING YOUR RV.

- B. Check all connections in the LP gas system (at the back of the refrigerator) for gas leaks. The LP gas supply must be turned on. Apply a non-corrosive bubble solution to all LP gas connections. The appearance of bubbles indicates a leak and should be repaired immediately by a **QUALIFIED SERVICEMAN WHO IS FAMILIAR WITH GAS SYSTEM AND REFRIGERATORS.**

WARNING: DO NOT use a flame to check for gas leaks.

- C. Check the AMES control system by connecting/disconnecting 120 volt AC power, start/stop the engine, etc. Compare the operation with the operation described in description of operation modes. Side 7.

NOTE: The following maintenance is required once or twice a year, but should only be done by a qualified serviceman who is familiar with LP gas systems and refrigerators.

- D. The LP gas pressure should be checked and the main regulator re-adjusted if pressure is incorrect. The correct operating pressure is 11 inches of water column. The correct place to take the LP gas pressure is at the test port just ahead of the burner jet. (See Fig. 10).
- E. Inspect the flue baffle. It should be reasonably clean and free of soot. Heavy soot formation indicates improper functioning of the burner. The flue and burner both require cleaning in the following manner:
1. Unplug the refrigerator power cord from the 120 volt AC outlet. (See Fig. 3).
 2. Disconnect or shut off the 12 volt power to the refrigerator.
 3. Turn manual shutoff valve to OFF. (See Fig. 1.)
 4. Remove cover from the burner housing. (See Fig. 1).
 5. Disconnect the wire from the high voltage electrode.
 6. Remove the burner mounting screws and remove the burner assembly. (See Fig. 10).
 7. Remove the flue cap from top of flue tube and lift out the wire and spiral baffle. Clean the flue from the top using a flue brush. Blowing compressed air into the flue will not properly clean soot and scale out of the flue tube. Replace spiral baffle and flue cap.
 8. Clean burner tube with a brush. Blow out burner with compressed air.
 9. Before removing burner jet, clean burner area of soot and scale that fell out of flue tube. Remove the burner jet. Soak the jet in wood alcohol and blow it out with compressed air. Re-install and tighten burner jet.

NOTE: The color of the flame should be clear blue over the slots of the burner. (See Fig. 11).

CAUTION: DO NOT use a wire or pin when cleaning the burner jet as damage can occur to the precision opening.

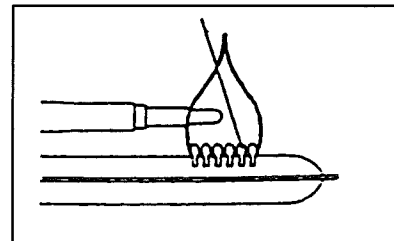
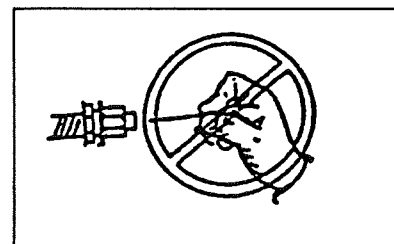

Figure 11

This can cause damage to the refrigerator or create a fire hazard.

10. Reinstall burner, being careful that the end of the burner fits into the slot on the burner bracket. Check to make sure slots are centered under the flue tube and the thermocouple is positioned properly (tip of thermocouple extends over two slots of burner).



11. Be sure to reconnect the wire to high voltage electrode. Check the electrode for proper location and gap. (See Fig. 12).
12. Turn on manual gas shutoff valve and check all fittings for leaks.
13. Connect 120 volt power cord to the outlet and reconnect or turn on the 12 volt DC power.
14. Check Lp gas safety shutoff. See side 6.

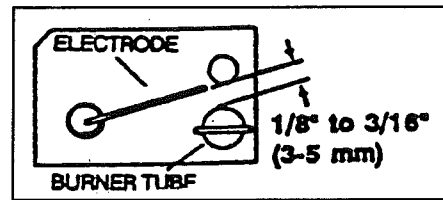

FAILURE OF REFRIGERATOR

Failure of refrigeration does not necessarily indicate that the cooling system is defective. Other factors governing its operation must be checked.

1. Common.

- 1a. Fuse(s) blown, replace (see side 11).
- 1b. Check level of refrigerator.
- 1c. Venting problem. Restriction in air flow across cooling unit
- 1d. Heavy frost buildup on evaporator fins, defrost.
- 1e. If the refrigerator has been operating on gas and a loss of cooling is noted, convert the refrigerator to AC power (see start up instructions side 8).

If the refrigerator has been operating on AC, switch to gas operation. This will determine if a component failure in the electric or gas controls is causing the cooling fault. After the refrigerator has been converted from one power source to the other (gas to AC, or AC to gas) allow time to assure the unit is cycling properly. At the end of the period the freezer plate should start to cool.

- 1f. A minimum of 9.6 volt DC supply present for the refrigerator control system.
- 1g. The thermostat can not be moved from MID position to the desired setting. The display module has become non functional. See limp mode of operation (side 9).
- 1h. The refrigerator is running continuously and cool to much.
The temperature sensing device has become non functional. See limp mode of operation (side 9).

2. Gas operation only.

- 2.1 The refrigerator will not operate on gas when AC is present.
The display module has become non functional. See limp mode of operation (side 9).
- 2.2 Burner jet clogged. Clean. See Section Maintenance/service, Item 2. Periodic maintenance, Paragraph E, Item 9.
- 2.3 Flue baffle not inserted properly in flue tube (see side 3, Fig. 1).
- 2.4 Burner dirty. Clean. See Section Maintenance/service, Item 2. Periodic Maintenance, Paragraph E, Item 8.
- 2.5 LP gas pressure low at burner.

Set main regulator so pressure does not drop below 11 inches water column at pressure test port (see side 11, Fig. 11).

- 2.6 Burner not located properly under flue tube, relocate.
- 2.7 Burner damage, replace.

ODOR FROM FUMES

Causes and Remedies

- A. The flame touches side of the boiler due to dislocation of the burner. Relocate. Burner dislocation may also cause smoke and discoloring of walls and ceiling.
- B. Burner damaged. Replace.

All the above instructions are to be followed closely. The refrigerator is quality-guaranteed. However, we are not responsible for any failures caused by improper adjustments and unfavorable installation conditions. Contact service point or distributor service dept. for assistance.

Replacement Parts Suppliers: See page 1.

CHANGING DOOR HINGES FROM ONE SIDE TO THE OTHER

Open the top door and remove the two screws holding the top decoration. The screws are accessible from beneath. (See Fig. 12).

Remove the top hinge pin and lift out the top door.

Remove center hinge pin and lift out the lower door. Unscrew the bottom hinge pin. Remove the plastic cap from the opposite lower hinge and place it in the hole just left empty by the lower hinge pin. Screw the lower hinge pin in the hole from which the plastic cap was removed.

Before replacing the doors on the refrigerator, remove the catches and move them to the opposite side of the cabinet. The screw holes are covered with plastic caps that must be removed and inserted in the screw holes that previously held the catches. NOTE: The plastic caps are not installed on new refrigerators and are in the parts bag.

Remount the doors and hinge pins in the reverse order of their removal. Gently pry off the decorative cover plates from the door handles. This will expose the screws that secure them to the door. Unscrew the handles and refasten them on the opposite side of the door. Snap the plastic cover plate back in position on the door handle. Insert the plastic caps (from the parts bag) into the holes left open on the doors. Check travel latch to make sure it works properly and the doors close easily. Check the door gaskets. If they are correct, then replace the top decoration.

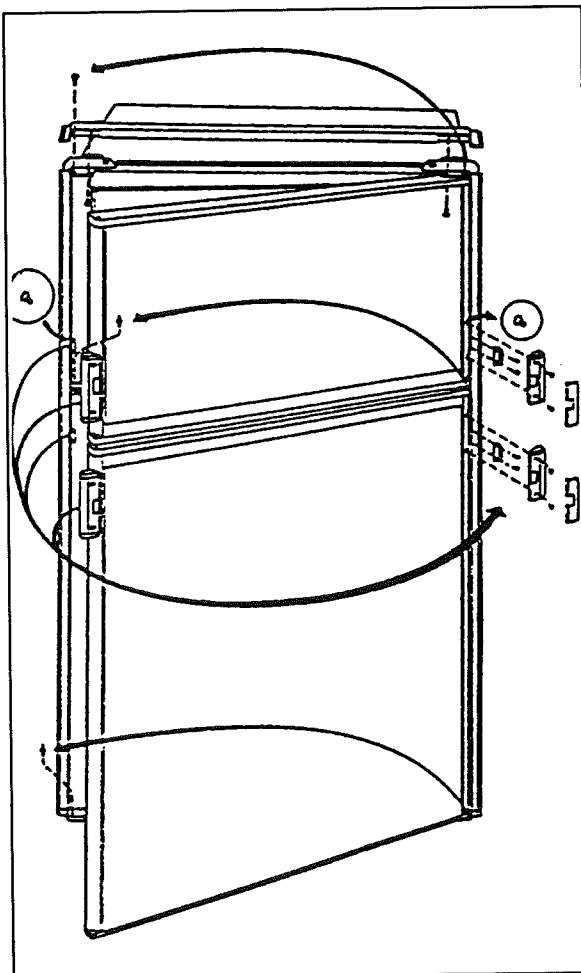
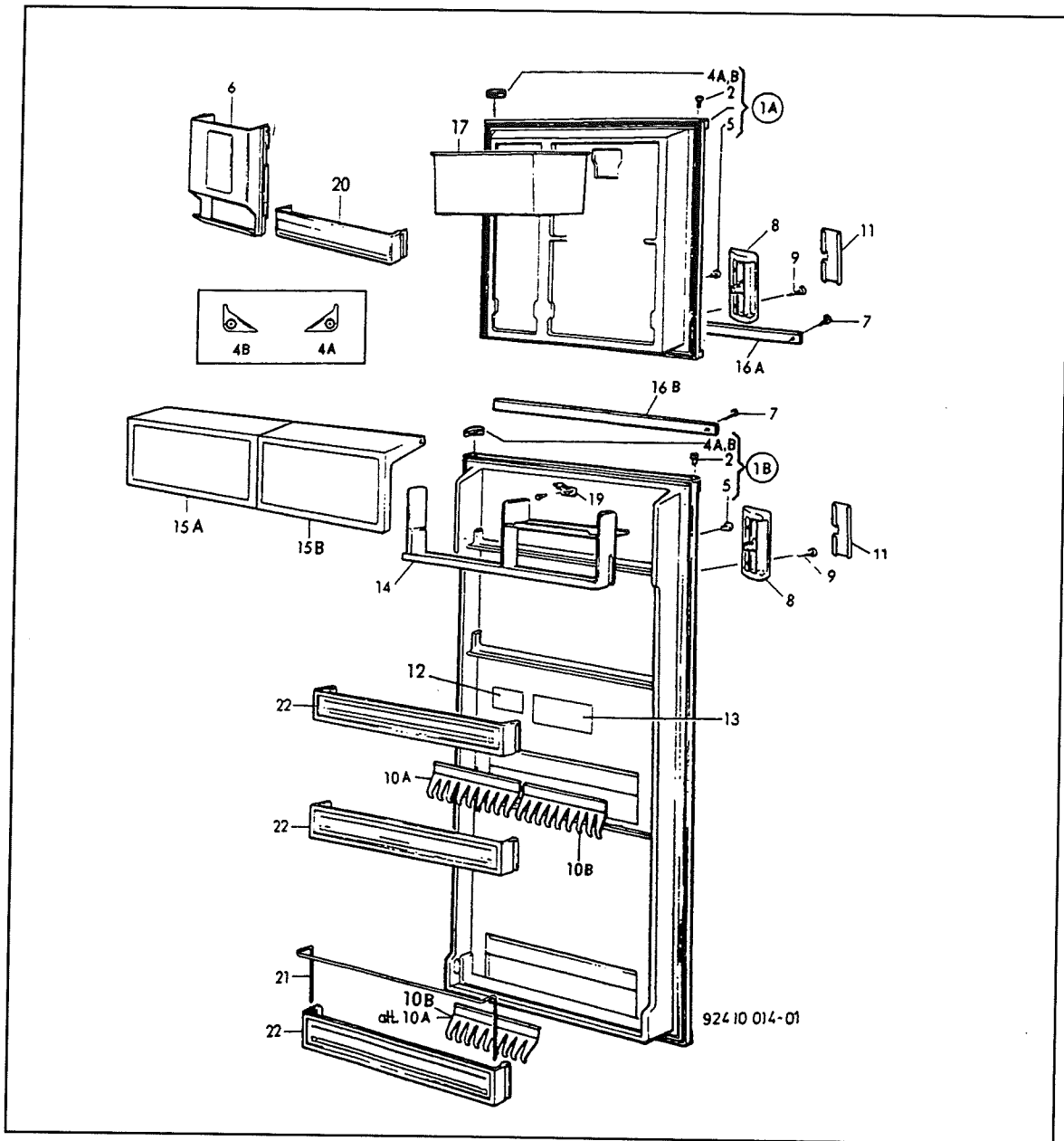

Figure 13



RM3807

A = RM3807 (921 60 06-01, 921 60 14-01) B = RM3807 (921 60 08-01, 921 60 16-01)

POS. NO	PART NO		DESCRIPTION	POS. NO	PART NO		DESCRIPTION
1A	293 16 42-11/6	A B	Door, upper	13	200 23 56-00/0	A B	Label 'Important'
1 B	293 16 41-11/8	A B	Door, lower	14	293 05 34-01/7	A B	Shelf
2	293 11 71-01/7	A B	* Bushing	15A	293 05 40-05/5	- B	Cover butter compartment, left
4A	293 15 12-01/2	A B	* Washer		293 05 40-06/3	A -	Cover butter compartment, left
4B	293 15 12-02/0	A B	* Washer	15B	293 05 40-04/8	A B	Cover butter compartment, right
5	293 15 10-03/2	A B	* Plug	16A	293 11 63-01/4	A B	Strip decoration, freezer
6	293 05 33-01/9	A B	Retainer	16B	293 11 63-09/7	A B	Strip decoration, fridge
7	729 52 29-01/2	A B	Screw, B4x16, zincplated	17	293 05 36-01/2	A B	Box
8	293 11 99-01/8	A B	Handle	19	293 05 94-01/1	A B	Flap bracket
9	729 52 25-01/0	A B	Screw, RXS, B4x10, zincplated	20	293 05 58-02/4	A B	Shelf door
10A	293 07 15-03/8	A B	Holder bottle, Approx 7 1/2", grey beige	21	200 17 34-00/9	A B	Rack
10B	293 07 15-04/6	A B	Holder bottle, Approx 8", grey beige	22	200 17 32-14/4	A B	Shelf door, 3 pieces
11	293 15 71-01/8	A B	CoverPlate				
12	293 16 20-00/5	A B	Label, 'Warning: Improper installation'				

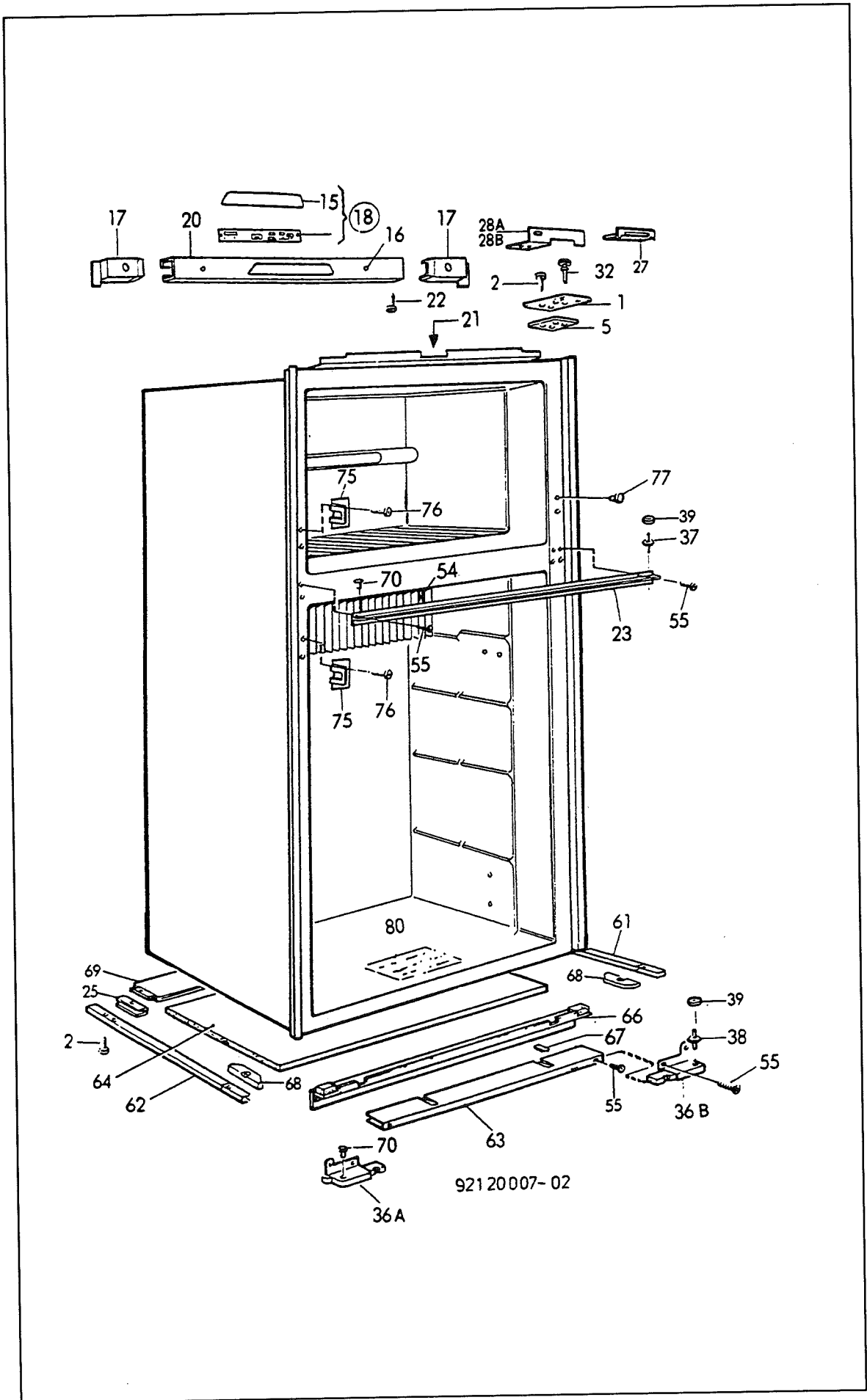

RM3807

A = RM3807 (921 60 06-01, 921 60 14-01)

B = RM3807 (921 60 08-01, 921 60 16-01)

POS. NO.	PART NO			DESCRIPTION
1	293 12 91-01/3	A	B	Hinge,upper
2	724 13 28-61/1	A	B	Screw, M5x14, zincplated
5	293 12 92-01/1	A	B	Washer
15	95 50 02-72/0	-	B	Decoration
	95 50 02-73/8	A	-	Decoration
16	293 01 32-06/9	A	B	Plug
17	293 18 66-01/2	A	B	Side plate, right
	293 18 66-02/0	A	B	Side plate, left
18	293 18 46-01/4	-	B	Circuit board
	293 19 06-01/6	A	-	Circuit board
20	293 18 65-05/5	A	B	Front
21	293 13 04-00/6	A	B	Label, 'This refrigerator must be installed.'
22	729 82 79-11/3	A	B	Screw, B6x9, 5, zincplated
23	293 12 90-01/5	A	B	Centre beam
25	293 07 74-01/9	A	B	Reinforcement
27	293 15 74-01/2	A	B	Sealing
28A	293 14 59-01/6	A	B	Plate mounting, left
28B	293 14 59-02/4	A	B	Plate mounting, right
32	293 12 88-01/9	A	B	Hinge pin,upper
36A	293 12 83-01/0	A	B	Hinge, lower, left
36B	293 12 83-02/8	A	B	Hinge, lower, right
37	293 12 87-01/1	A	B	Hinge pin, middle
38	293 12 86-01/3	A	B	Hinge pin, lower
39	734 49 04-03/7	A	B	Washer
54	293 19 76-01/9	A	B	Retainer
55	724 32 91-61/9	A	B	Screw, M4x12, zincplated
61	293 12 81-01/4	A	B	Runner, right
62	293 12 81-02/2	A	B	Runner,left
63	293 12 82-04/6	A	B	Base front
64	293 07 11-02/9	A	B	Insulation
66	293 16 28-02/4	A	B	Strip sealing
67	293 12 85-01/5	A	B	Coverplate
68	293 15 04-01/9	A	B	Reinforcement
69	293 06 64-01/2	A	B	Protection plate
70	293 12 84-02/6	A	B	Plug, dark grey
75	293 15 11-01/4	A	B	Bracket
76	729 52 21-01/9	A	B	Screw, RXS, B4x6, 5, zincplated
77	293 15 10-03/2	A	B	Plug
80	293 19 08-00/4	A	-	Sign plate
	293 19 09-00/2	-	B	Sign plate

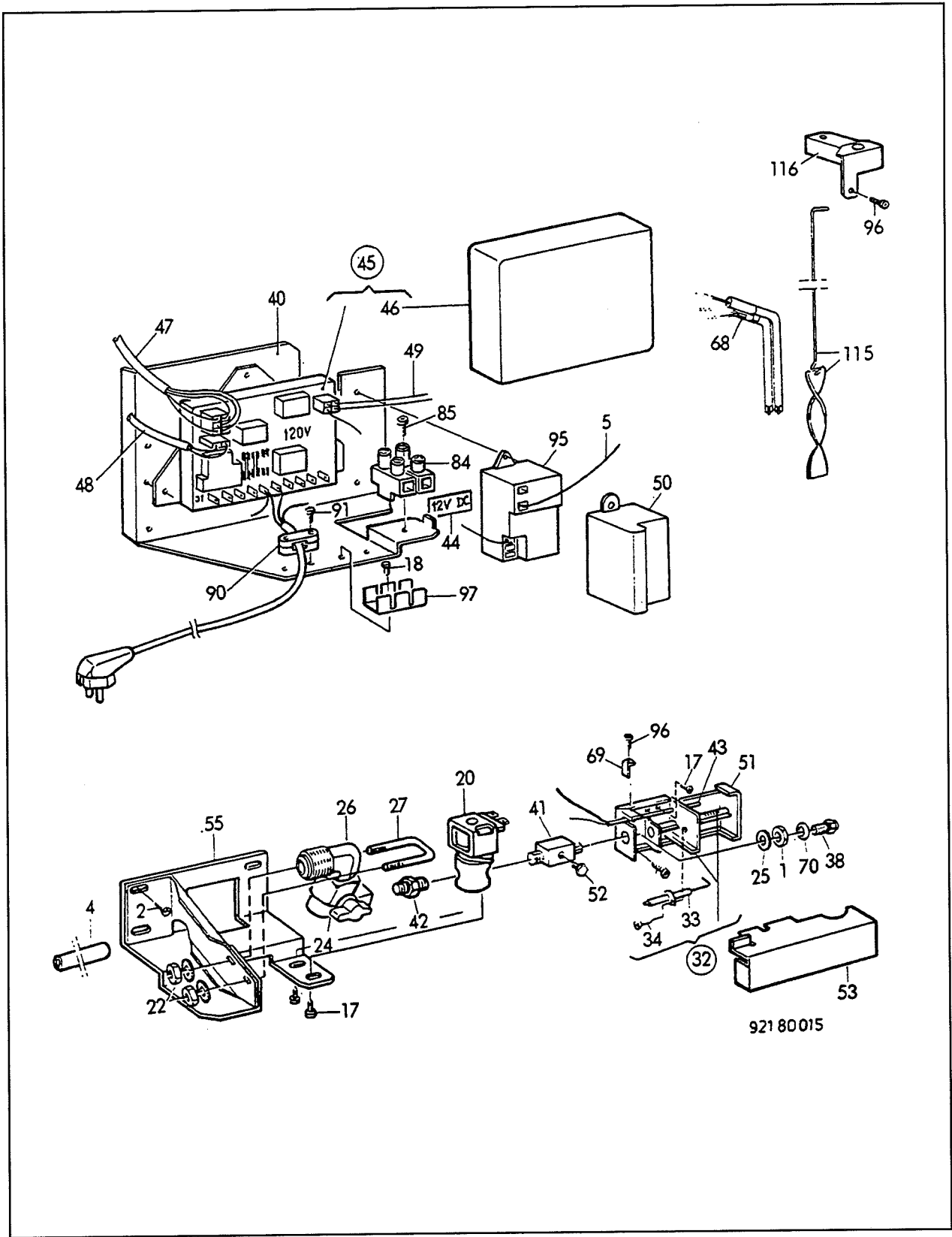

RM3807

A = RM3807 (921 60 06-01, 921 60 14-01)

B = RM3807 (921 60 08-01, 921 60 16-01)

POS. NO	PART NO					DESCRIPTION
1	14	02	07-04/4	A	B	Nut
2	724	13	28-61/1	A	B	Screw, M5x14, zincplated
4	293	20	01-01/5	A	B	Hose
5	200	76	68-05/2	A	B	Conductor electrode
17	724	12	87-61/9	A	B	Screw, M4x8, zincplated
18	724	12	89-61/5	A	B	Screw, MRX, M4x10, zincplated
20	294	32	98-00/6	A	B	Valve solenoid
22	294	32	86-00/1	A	B	Nut lock
24	294	32	99-00/4	A	B	Valve gas-
25	734	58	42-01/2	A	B	Washer
26	293	19	16-01/5	A	B	Nipple
27	294	32	85-00/3	A	B	Bolt, U
32	293	06	97-02/0	A	B	Burner
33	293	03	79-00/9	A	B	* Electrode
34	729	52	21-01/9	A	B	* Screw, RXS, B4x6, 5, zincplated
38	200	74	19-21/7	A	B	Jet, no. 58
40	293	18	22-01/5	A	B	Retainer
41	293	18	24-01/1	A	B	Nipple
42	293	18	25-02/6	A	B	Nipple
43	293	18	26-01/6	A	B	Thermocouple
44	293	18	274)0/6	A	B	Sign plate
45	293	18	42-01/3	A	-	Circuit board
	293	18	43-01/1	-	B	Circuit board
46	293	18	58-01/9	A	B	* Cover
47	293	18	62-01/1	A	B	Conductor, circuit card
48	293	18	63-01/9	A	B	Conductor, thermistor
49	293	18	64-01/7	A	B	Conductor, gas valve
50	293	18	86-01/0	A	B	Cover
51	293	19	13-01/2	A	B	Burner housing
52	16	93	80-00/3	A	B	Screw
53	293	15	72-01/6	A	B	Protection plate
55	293	19	15-01/7	A	B	Cantilever
68	17	37	42-16/4	A	B	Heater, 325 W, 120V
	17	37	57-06/3	-	B	Heater, 215 W, 12V
69	293	06	60-01/0	A	B	Retainer
70	200	74	57-00/1	A	B	Washer
84	293	04	63-01/9	A	B	Terminal block
85	729	52	87-40/8	A	B	Screw, RXS, B6x25, stainless
90	56	10	14-01/0	A	B	Anti-strain dip
91	729	52	85-40/2	A	B	Screw, RXS, B6x19, stainless
95	293	11	32-01/9	A	B	Spark ignition device
96	729	52	79-01/7	A	B	Screw, RXS, B6x10, zincplated
97	293	03	27-00/8	A	B	Terminal rail
115	200	75	90-06/6	A	B	Baffle
116	293	15	40-01/3	A	B	Flue

RM3807

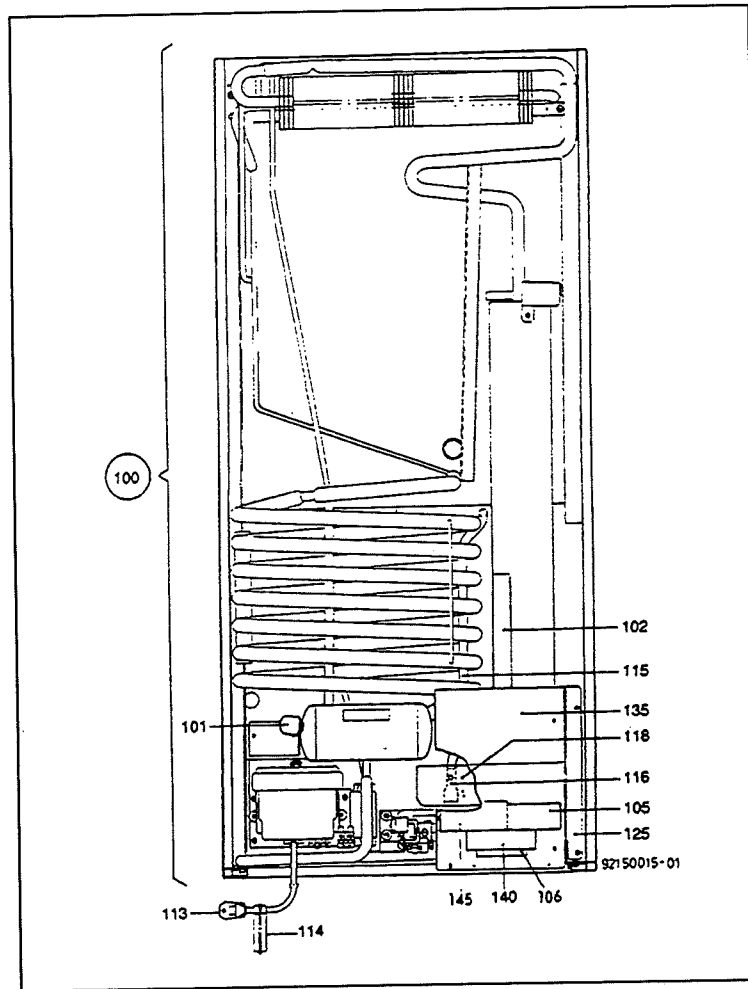

POS. NO	PART NO	DESCRIPTION
100	293 49 03-99/4	Cooling unit, 2934903-01 +emb
101	17 32 28-00/8	* Cap
102	293 35 57-00/7	* Cover
105	293 15 03-00/3	Sign plate 'Installation clearances'
106	200 75 74-02/9	Sign plate 'Install only'
113	200 26 99-06/0	Cord set
114	200 25 76-00/3	Label 'Warning electrical grounding instructions'
115	293 15 79-04/5	Hose
116	293 18 29-01/0	Outlet tube
118	293 18 28-01/2	Tray
125	293 07 84-01/8	Protection plate
135	293 07 85-01/5	Protection plate
140	200 25 77-00/1	Label 'When testing. . '
145	200 76 89-00/9	Label 'Important'

WIRING DIAGRAM

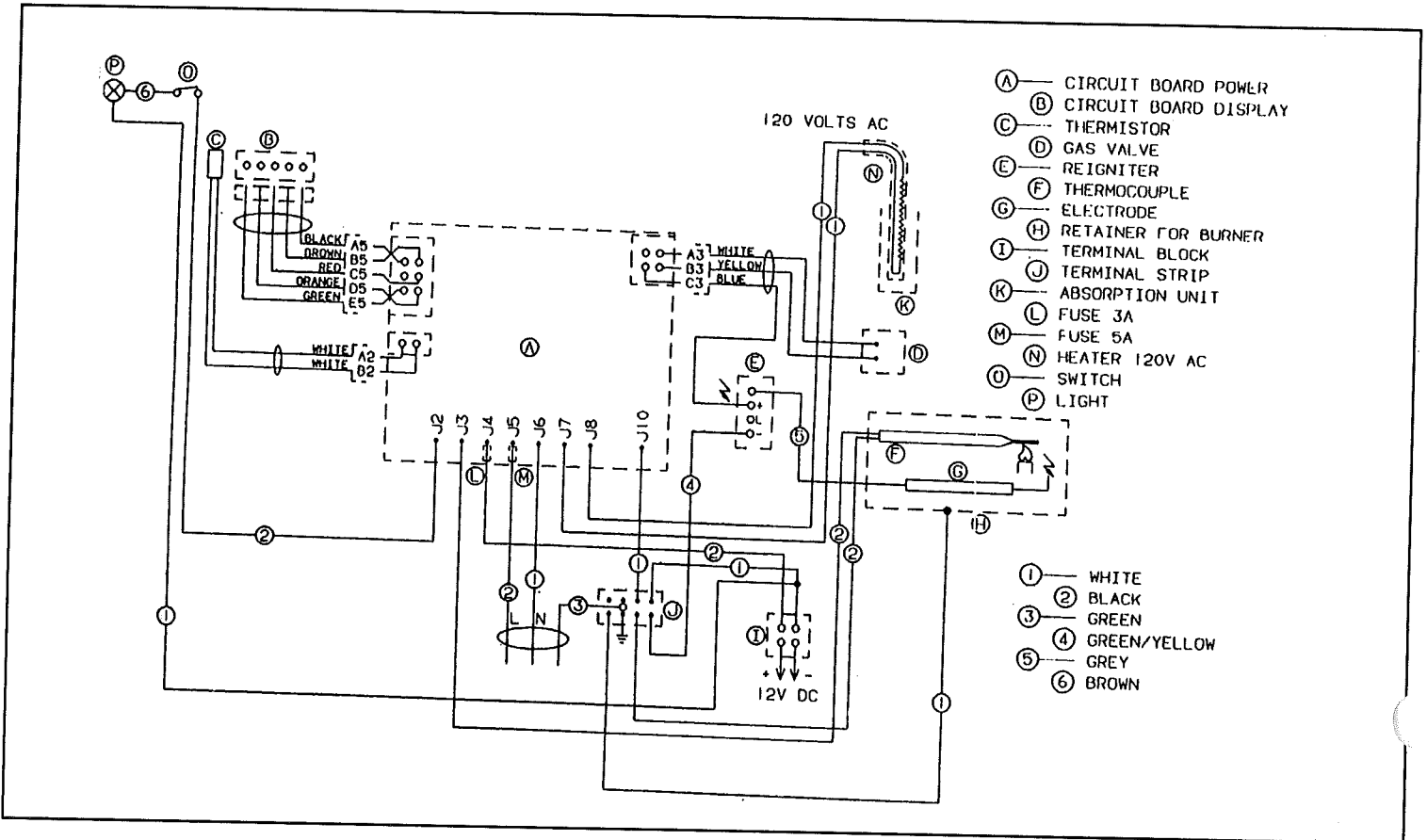
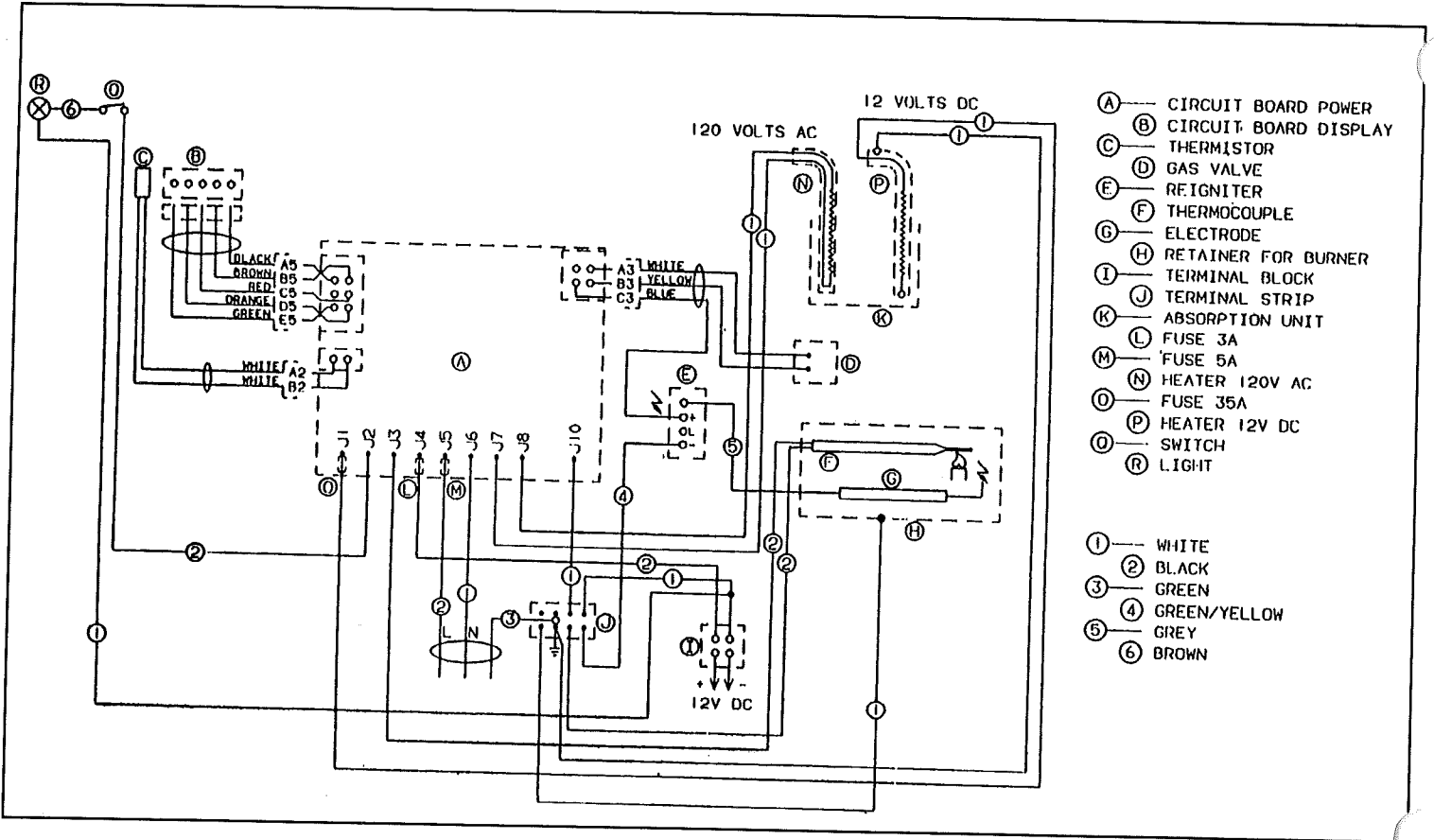

NOTES

RANGE AND OVEN

Manufacturer: Wedgewood Ranges
Atwood Mobile Products
P.O. Box R, Kelly Willis Rd.
Greenbrier, TN 37073
Phone: 615-643-4556

The range and oven in your Airstream works on LP gas. The oven is optional and may not be included on your motorhome.

People using gas ranges in the home will find little difference in the operation of the range in the motorhome. Other customers, used to electric ranges, may be a little apprehensive at first, but will quickly gain confidence. The basic operation of the gas range has been the same for many years; but please be sure to read all the directions furnished by the manufacturer and located in the Owner's Packet.

We find many experienced RVers do not use the pilot light for the top burners, preferring the flint type hand lighters instead. The main reason the pilots aren't used is due to the size of the motorhome and the climate in which most motorhomes are used. The pilots are very small, but, of course, produce heat that may be noticeable in the motorhome. With limited counterspace it is normal to set articles on the closed top of the range. If the day is hot and the article is plastic it may become deformed from the low but constant heat of the pilot.

OPERATION

NOTE: A range pilot (top lighter) is an optional feature. An oven pilot is standard on all range models with an oven.

WARNING: If pilot should extinguish (after initial lighting or due to accidental blow-out), turn gas supply off and wait (5) minutes before again attempting to light the pilot.

CAUTION: For safe operation, top burners should always be adjusted so that flame never extends beyond the edge of the cooking utensil.

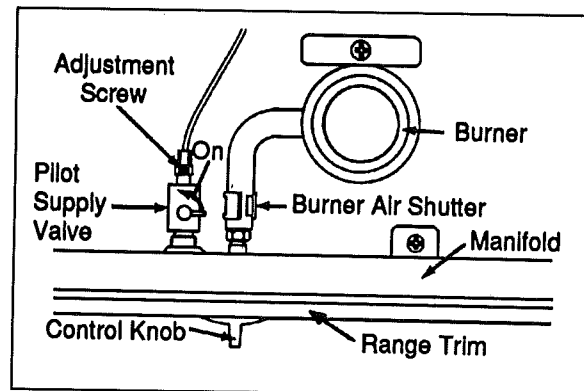

1. To light range pilot:
 - a. Verify gas supply is sufficient.
 - b. Turn all controls to OFF.
 - c. Lift or remove range top.
 - d. Turn pilot supply valve on (Figure 2).
 - e. Light pilot.

NOTE: The range pilot can be adjusted by the brass screw on the pilot supply valve. Turn screw clockwise to decrease flame, counterclockwise to increase flame. Pilot flame should extend 3/8 inch above pilot assembly cup.

- f. Close (or replace) range top.
- g. To extinguish range pilot, simply turn pilot supply valve off.

2. To light oven pilot:
 - a. Verify gas supply is sufficient.
 - b. Push in oven control knob and rotate counterclockwise to PILOT ON.
 - c. Light oven pilot located at back of oven to the left of the oven burner (Figure 3).

NOTE: The oven pilot may be slow in lighting due to initial air in the gas lines.

NOTE: The oven pilot has been factory adjusted, and requires no further adjustment.

- d. To extinguish oven pilot, push in oven control knob and turn clockwise to OFF.

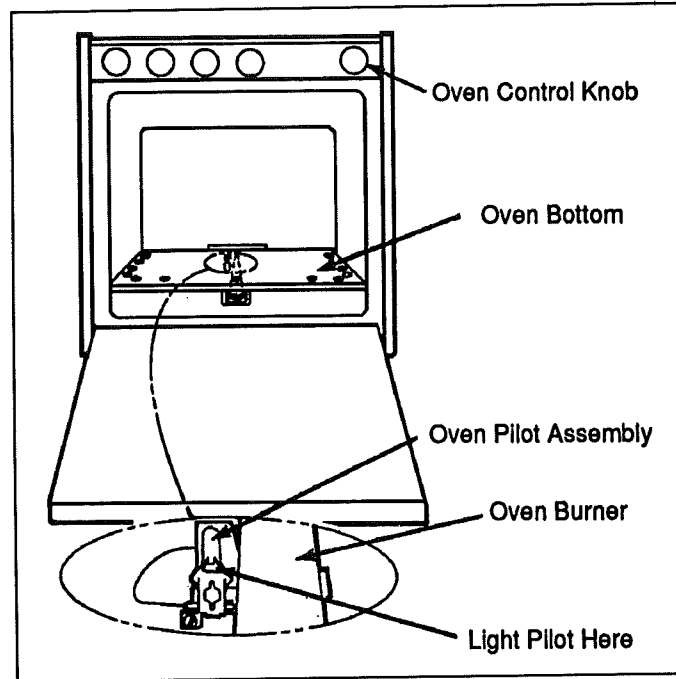

FIGURE 3
LIGHTING OVEN PILOT

3. To light Spark Ignition range models:
 - a. Verify gas supply is sufficient.
 - b. Turn desired top burner on.
 - c. Wait approximately (7) seconds and push red ignitor button.
4. All burner and oven controls operate counterclockwise, and must be pressed inward to turn control on. The oven control must also be pressed inward to turn control to OFF, past PILOT ON position.
5. Check flames on top burners and oven burner; adjust air mixture if necessary. To adjust burner flame, turn burner's air-shutter (see Figure 2) to increase air mixture until flame has yellow tips but does not lift off burner ports. Then, adjust air shutter until the yellow tips of the flame are eliminated. This will provide maximum flame efficiency without flame blow-out.

NOTE: Top burner flames are preset at the factory on all models without optional range pilot, (top lighter).

6. To operate the oven, turn oven control counterclockwise to the desired temperature. The oven will pre-heat in approximately 10 minutes.

NOTE:

The oven is equipped with a safety ignition system that requires a minimum of 30 seconds to operate after turning oven knob on.

NOTE: Do not cover the ventilation holes in oven bottom (shelf above oven burner).

7. When broiling (a 2-piece enamel broiler pan can be purchased from Wedgewood Operations):
 - a. center the broiler pan under the flame.
 - b. move and turn the food over frequently to ensure even browning and cooking.

MAINTENANCE

The owners cooking habits and cleanliness will affect the operation of a range. With proper installation and care this range should provide many years of maintenance-free performance.

Some of the more common range operating difficulties (their probable causes and remedies) are detailed in the Fault Isolation Chart (Figure 4).

1. Clean all surfaces as soon as possible after spills or spotting. Use warm soapy water only. Grit or acid-type cleaners should never be used.
 - a. never wash warm porcelain surfaces.
 - b. pitting and discoloration will result if spills are allowed to remain for any length of time on stainless steel.
 - c. use oven cleaner on oven interior. Follow directions on the can.

RANGE TOP

To remove:

- a. remove all burner grates.
- b. lift top upward by front edge and pull out, away from rear vent trim.

To replace:

- a. insert lip on rear edge of range top beneath the rear vent trim.
- b. lower range top into place.
- c. apply a slight downward pressure on both sides in order to engage the retaining clips.

CAUTION: On models with a range pilot, be sure burner pilot flash tubes are in place and the pilot is burning before replacing top.

MAINTENANCE (Continued)

FAULT ISOLATION

Malfunction	Probable Cause	Remedy
<p>A. Range pilot won't light or stay lit.</p>	<ol style="list-style-type: none"> 1. Supply Valve closed. 2. Insufficient gas supply. 3. Insufficient gas pressure. 4. Blocked pilot orifice, or blocked flash tubes. 5. Pilot flame too high or too low. 6. Pilot flame cover out of position, and/or coated with carbon. 7. Pilot flame blow-out. 	<ol style="list-style-type: none"> 1. Turn valve on. 2. Check gas supply. 3. Check for gas leaks and have regulator checked by qualified LP gas technician. 4. Clean pilot orifice with toothpick; clean flash tubes. 5. Adjust pilot flame. Refer to #5 page 4. 6. Reposition pilot flame cover, and/or remove carbon buildup. 7. If range is installed near an open window, the pilot may not stay lit on a windy day. <p>CAUTION: Turn off gas and wait 5 minutes before relighting.</p>
<p>B. Burner(s) won't light or stay lit.</p>	<ol style="list-style-type: none"> 1. Insufficient gas pressure. 2. Incorrect air/gas mixture. 	<ol style="list-style-type: none"> 1. Check for gas leaks, and have regulator checked by qualified LP gas technician. 2. Adjust air shutter. Refer to #5 page 4.
<p>C. Burner lights, but flame is too small.</p>	<ol style="list-style-type: none"> 1. Improper gas pressure. 2. Improper air/gas mixture (on range pilot models only). 	<ol style="list-style-type: none"> 1. Check for gas leaks, and have regulator checked by qualified LP gas technician. 2. Adjust air shutter. Refer to #5 page 4.
<p>D. Burner flame lifts off burner head.</p>	<ol style="list-style-type: none"> 1. Gas pressure too high. 2. Incorrect air/gas mixture (on range pilot models only). 	<ol style="list-style-type: none"> 1. Have regulator checked by a qualified LP gas technician. 2. Adjust air shutter (on range pilot models only).
<p>E. Oven burner lights, but flame remains very small and oven heats very slowly.</p>	<ol style="list-style-type: none"> 1. Improper gas pressure. 	<ol style="list-style-type: none"> 1. Check for gas leaks, and have regulator checked by qualified LP gas technician.
<p>F. Oven burner flame lifts off burner and oven cycles too frequently.</p>	<ol style="list-style-type: none"> 1. Gas pressure too high. 	<ol style="list-style-type: none"> 1. Have regulator checked by qualified LP gas technician.
<p>G. Oven cooks unevenly and/or food burns on the bottom.</p>	<ol style="list-style-type: none"> 1. Poor oven ventilation. 	<ol style="list-style-type: none"> 1. Oven too full for proper circulation, and/or ventilation holes in oven bottom (shelf above burner) are covered.

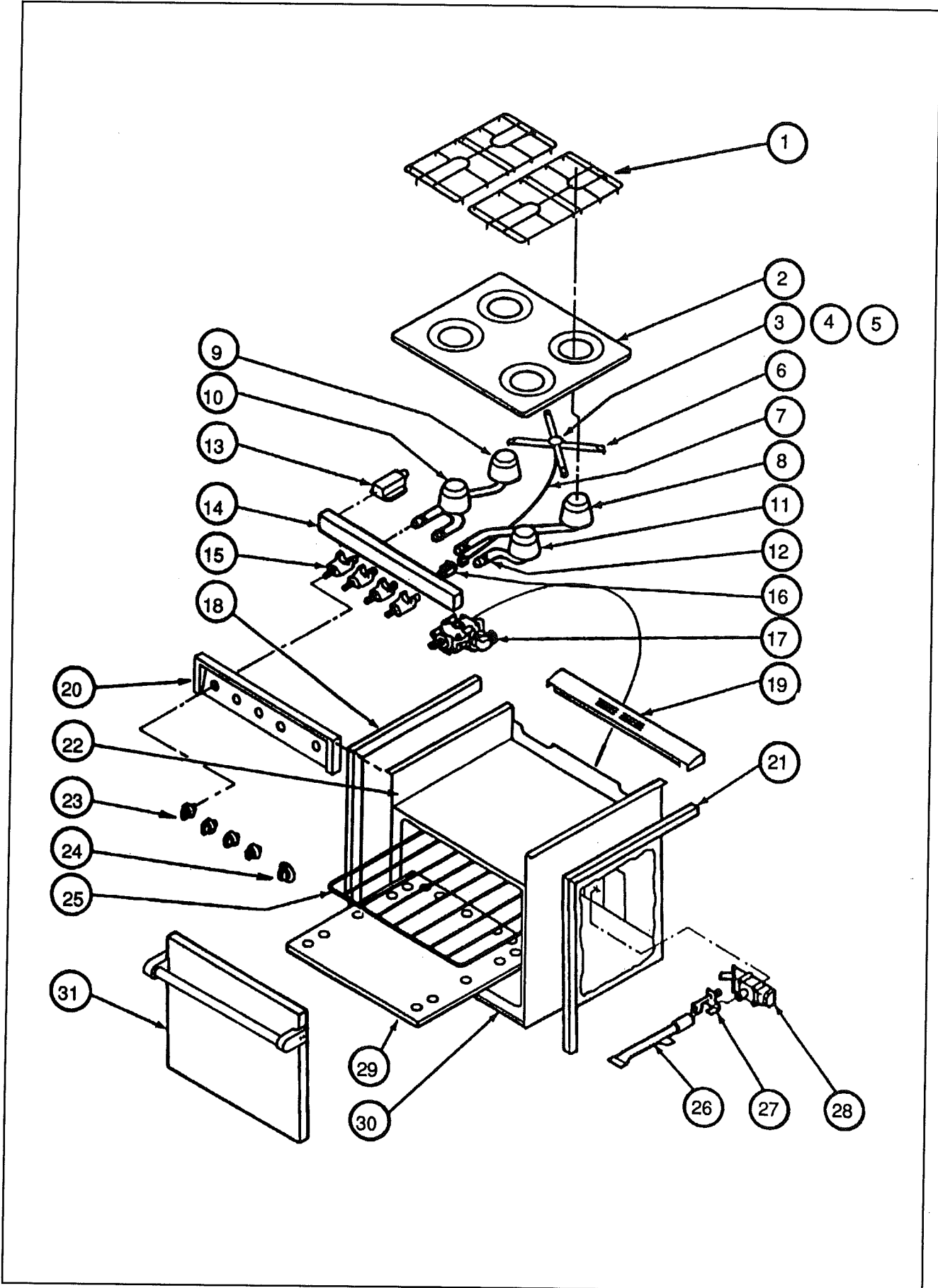

ITEM	DESCRIPTION	PART NO.
1	Grate, Top, Dual	53007
2	Range, Top	order by color
3	Pilot cluster holder	*
4	Pilot shield	*
5	Top pilot adapter	*
8	Flash tubes, top lighter	*
7	Pilot gas supply tube	*
8	Burner, right rear	51243
9	Burner, left rear	51242
10	Burner, left front	51240
11	Burner, right front	51241
12	Air shutter	51208
13	Extreme pressure regulator	51062
14	Manifold, 4 burner	52284
15	Valve, burner	51096
16	Top Pilot Valve kit	51066
17	Thermostat, oven control	51095
18	Trim, left hand top and side (black)	53023
18	Trim, left hand top and side (stainless steel)	53523
19	Trim, vent (black)	53025
20	Manifold cover (black)	53556
21	Trim, right hand top and side (black)	53024
21	Trim, right hand top and side (stainless steel)	53524
22	Burner box	51684
23	Knob, burner (Package of 2)	51056
24	Knob, thermostat	51057
25	Oven rack	51069
28	Burner, oven	52018
27	Pilot assembly, oven	51065
28	Safety Valve	51063
28	Shelf, oven bottom	51657
30	Trim, bottom (black)	53526
30	Trim, bottom (stainless steel)	53668
N/S	Burner Ignitor kit	51077
N/S	Designer Accessory Kit	51071
N/S	Gas Tube kit	51068
Doors & Door Parts		
31	Door assembly, black glass	order by color
N/S	Handle, black glass door	53087
N/S	Handle, solid door	53086
N/S	Enamel door liner w/window	53611
N/S	Enamel door liner	53612
N/S	Solid door panel	53663
N/S	Insert, black glass	53426
N/S	Insert, black glass w/window	53446
N/S	Window, inner assembly	51421
N/S	Door Seal kit	51061

*Order Kit Number

WATER HEATER

Manufacturer: Atwood Mobile Products
4750 Hiawatha Drive
P.O. Box 1205
Rockford• Illinois 61105
Phone: 815-877-7461

Note: Review the water heater literature supplied in your Owner's Packet before proceeding.

CAUTION: Hydrogen gas can be produced in a hot water system served by this heater that has not been used for a long period of time (generally two weeks or more). Hydrogen gas is extremely flammable. To reduce the risk of injury under these conditions, it is recommended that the hot water faucet be opened for several minutes at the kitchen sink before using any electrical appliance connected to the hot water system. If hydrogen is present there will probably be an unusual sound such as air escaping through the pipe as the water begins to flow. There should be no smoking or open flame near the faucet at the time it is open.

Electronic Ignition

The switch used to light your electronic ignition water heater is located in the bathroom above the lavatory top. When the switch is turned on, the red light will come on indicating the "try" mode is in effect. Normally the burner will ignite in just a few seconds, and the light will go out. If your LP system hasn't been used for some time, the system may go into safety lock-out (about 20 seconds) before the air is all expelled from the lines. Turning the switch off for 30 seconds, then back on, reinstates the "try" mode. (See Note below.)

Principle of Operation

When the switch is turned on, power is supplied to the thermostat (located inside the junction box at the back of the water heater). When the thermostat senses the water in the tank requires heat (below 120°F), its contacts close and complete the circuit to the circuit board. This will energize the coils in the dual solenoid gas valve, allowing gas to flow out of the main burner orifice, mix with air at the ventura (air adjusting slots), then flow out the end of the main burner.

Simultaneously the coil on the circuit board provides a high voltage current to reach the spark probe at the main burner. This ignites the gas. When the flame is sensed by the probe, current is conducted to the relay and the valve remains energized. Sparking ceases when the electrode to ground current path is altered by the presence of flame. The water heating process begins. When the water in the tank drops below 120°F, the process will automatically repeat itself.

Note: A complaint sometimes received at Airstream is the fact the water heater will not light for a while when the motorhome is first parked. The explanation is easy. The water is already hot! The motorhome water heater has a heat exchanger plumbed into the engine radiator system. As you are driving the water is being heated without your having to do a thing.

SAFETY

ECO Switch: The unit is equipped with an ECO (Energy Cut-Off) switch. This is located next to the thermostat and, should the water exceed 190° F, the contacts in the ECO switch will open and completely shut off the power to the unit.

It is unlikely, but should this occur it is necessary to move the rectangular cover from the back (inside) of the unit and manually depress the red button. The unit should then be checked before continuing use to determine why the water overheated. Refer to trouble shooting section.

Relief Valve: Each unit is equipped with a temperature pressure relief valve. Should the water in the tank exceed 201° F or 150 PSI, the valve will open and allow cold water to enter and reduce the temperature of the water or release the pressure built up.

Circuit Board Lock-Out:

Should the spark not ignite the gas, a built-in timing circuit in the circuit board will shut down and the red light next to the interior switch will come on. It is necessary to shut this switch off, wait 30 seconds, then turn switch back on. If unit again fails to light, check trouble shooting section.

Storage and Winterization Procedure for Water Heaters

Normal storage and winterization procedures would be as follows:

1. Thoroughly drain the inner tank. Simply open the petcock drain valve contained at the front base of the unit. To assist in draining, plus to eliminate the chance of developing an air lock, also open your relief valve.
2. Once the unit has been thoroughly drained, approximately two quarts of water will remain in the base of the tank due to the position of the petcock drain valve. Strictly for winterization precautions, these remaining two quarts of water will not harm the unit. As this water freezes, it has ample room for expansion without causing freezing damage.

Adjustment for Direct Ignition Water Heater

The following are adjustments that can be made to all direct ignition water heaters. These adjustments will improve initial start up and recycling capabilities of the unit.

Air Shutter Positioning

The air shutter should be positioned in a manner that will allow the main burner flame to be blue with a trace or flash of yellow appearing through the flame. Approximate positioning is 1/4 way open. **Note Illus.** The importance of this adjustment is to allow an adequate air/gas mix to be ignited by the electrode at the end of the burner tube. If the air shutter is not positioned properly, this will minimize the unit's start up and recycling capabilities.

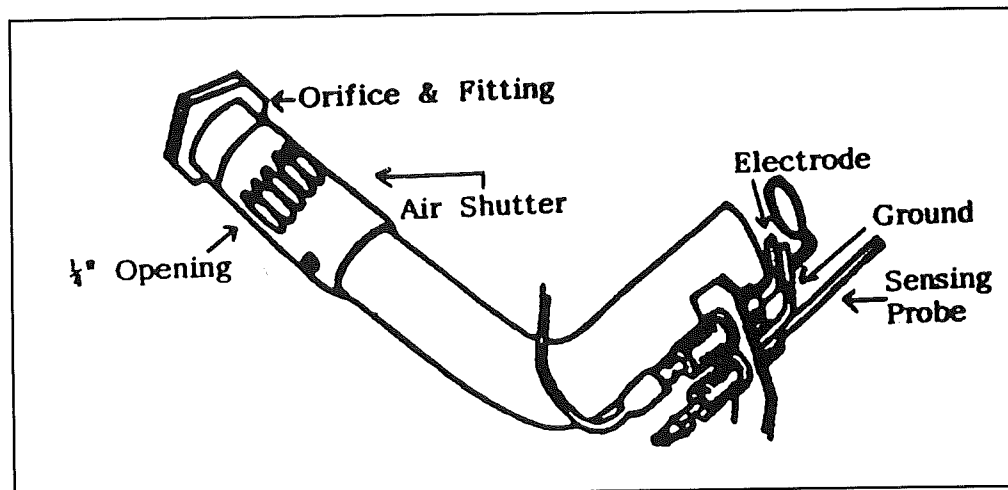

Main Burner Alignment

It is important that the air shutter is fitted over the orifice holder. It is also important that the orifice is centered in the main burner tube. This adjustment allows for the proper air/gas mix.

Electrode Positioning

The electrode and the ground probe should be positioned in the area between the end of the burner tube and the flame spreader. This adjustment allows for instantaneous start up and recycling. The flame sensing probe should not be grounded on the flame spreader or any other metal object in the combustion chamber. The sensing probe is the component part of the electrode that relays to the circuit board that a flame is present and everything is functioning properly. The flame sensing probe sends microamps to the circuit board. When the circuit board receives the proper amount of microamps, it allows the gas valve to stay open and the main burner flame to stay on. The male connector on the back of the flame sensing probe should be clean and free of corrosion, as should the female connector on the white wire. If the water heater initially starts up and runs for one minute or less, the probe could be at fault. First clean it. If this does not correct the problem, replace the electrode assembly. It is important to note that the air adjustment shutter positioning plays an important part in the functioning of the flame sensing probe. When the main burner flame is blue and not roaring, the flame spreads correctly and the sensing probe is heated quicker.

TROUBLE SHOOTING

General Test

If you are not sure if the water heater is functioning properly, there is a simple test you can perform. With the water heater off, run all the hot water out of the system by opening any of the faucets. Now light the water heater and time it until the burner shuts off. A good working heater will shut off within just a few minutes short of a half hour, as timed from a completely cold start up.

Temperature/Pressure Relief Valve

Problem: Weeping or dripping of relief valve while water heater is running DOES NOT mean it is defective. This is caused by the normal expansion of water as it is heated in the closed water system of a recreational vehicle.

The Atwood water heater tank is designed internally with an air gap at the top of the tank to reduce the possibility of this occurring. In time the expanding water will absorb this air. To replace the air:

- Remedy:**
- A. Turn off water heater.
 - B. Turn off incoming water supply.
 - C. Open a faucet in the coach.
 - D. Pull handle of P & T valve straight out and allow water to flow until it stops.
 - E. Allow P & T valve to snap shut. Close faucet and turn on water supply.

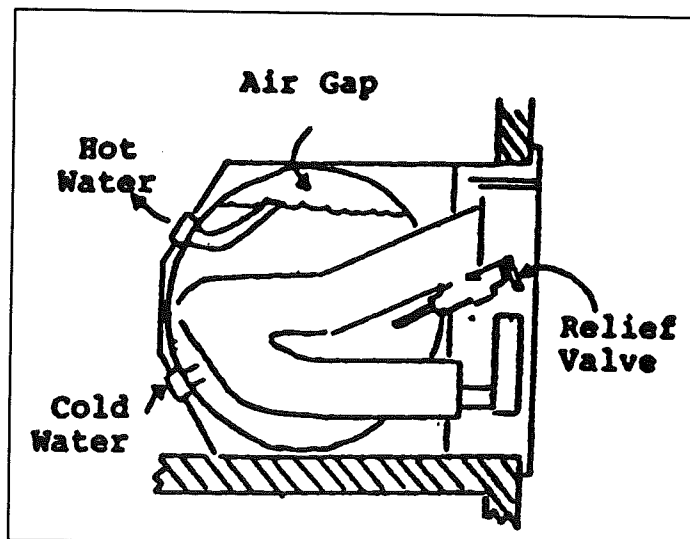

Electronic Ignition System

Problem: "Switch on" red light does not flash.

- Remedy:**
- A. Water in tank at 160 degrees. Drain off water below 160 degrees, then observe unit for start up.
 - B. Unit must be connected directly to battery. Battery must produce at least 10V DC. If lower, charge battery.
 - C. Remove cover from back of water heater and manually depress red reset button.
 - D. Check wiring of switch with diagram.
 - E. Defective interior switch. Replace.
 - F. Defective ECO switch. Check for closed contacts with continuity tester. Replace.
 - G. Defective thermostat. Contacts should be closed when thermostat is cooled. Replace.

Problem: "Switch on" red light remains on (not a flash).

- Remedy:**
- A. Inadequate voltage. Check battery.
 - B. Improper wiring. Check with diagram.
 - C. Circuit board ground wire or ground at back of unit broken or disconnected.
 - D. Flame sensing probe grounding to flame spreader or burner. Check by removing lead from probe. If unit goes through lock-out cycle, bend sensing probe away from flame spreader and replace lead.
 - E. Top of SCR contacting sheet metal casing with power off. Bend SCR top until contact with sheet metal is broken.

Problem: "Switch on" red light flashes then stays on.

- Remedy:**
- A. No gas supply. Check all valves to open. Unit must have minimum of 11" water column pressure.
 - B. Check connection to solenoid valve with volt meter. Should have 12V DC.
 - C. Defective solenoid valve. Test with good battery. One lead on case: one lead on white wire. An audible click should be heard.
 - D. Water temperature may be 160 degrees, causing contacts to fluctuate.
 - E. Defective circuit board. Replace.

Problem: "Switch on" red light flashes one time, then goes out. Unit not lit.

- Remedy:**
- A. Spark probe grounded. Proper gap 1/8" from center wire, burner tube and/or flame spreader.
 - B. Broken or shorted spark probe lead wire (heavy insulated, light brown.)
 - C. Temperature of water at 160 degrees allowing thermostat contacts to fluctuate.
 - D. Possible defective circuit board. Replace.

Problem: Yellow main burner flame.

- Remedy:**
- A. Improper air adjustment.
 - B. Partially plugged main burner orifice. Remove and clean.
DO NOT ENLARGE.
 - C. Obstruction in main burner tube. Spiders, rust etc. Remove and clean.
 - D. Bent or missing flame spreader. Straighten or replace.
 - E. Inadequate gas pressure into valve. Check with manometer-11" water column minimum.
 - F. Inadequate gas pressure at outlet side of valve. Remove pressure tap plug located at right front of solenoid valve. Insert 1/8" MPT pipe nipple. Hook up manometer. Turn on unit.
 - G. Grille in upper left hand side of grille obstructed. Filters, tape, etc. should not be used to block any portion of this grille.
 - E. Gas solenoid bracket bent. Orifice not pointed up center of main burner.

Problem: Tank leaks water.

- Remedy:**
- A. Check all plumbing fittings for leaks.
 - B. Tank Corrosion. Refer to warranty with unit.

Problem: Spark ignitor continues to spark while burner is on.

- Remedy:**
- A. Flame sensor not correctly positioned in flame.

PARTS DESCRIPTION WATER HEATER MODEL G6A-4E

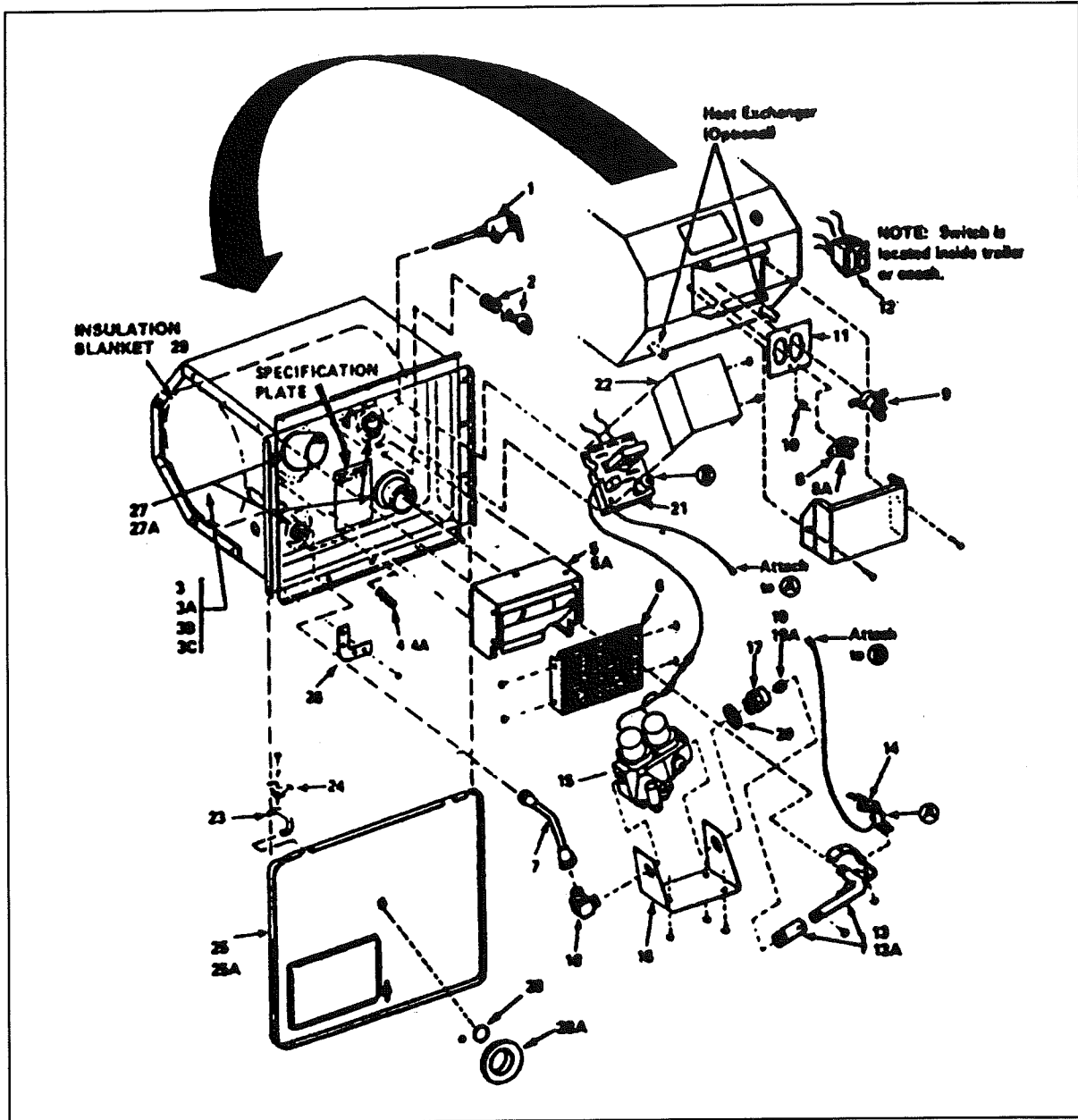

PARTS DESCRIPTION

- | | |
|-----------------------------------|---|
| 1. Relief valve 1/2" fitting | 16. Valve bracket |
| 2. Cam-loc fastener | 17. Orifice holder |
| 3. Inner tank | 18. Elbow fitting |
| 4. Drain plug | 19. Main burner orifice |
| 5. Flue box | 20. Washer gasket |
| 6. Exhaust grille | 21. Circuit board |
| 7. Gas inlet tube | 22. Circuit board cover |
| 8. Thermostat 12V LC, 140° preset | 23. Hinge pin |
| 9. ECO switch | 24. Hinge clip |
| 10. Lock-nut | 25. Access cover |
| 11. Control retainer plate | 26. Corner brackets (set of 4) |
| 12. Switch package | 27. Gasket kit (standard or high performance) |
| 13. Main burner | 28. Gasket for sight window |
| 14. Spark probe assembly | 28A. Access cover, sight window |
| 15. Gas valve | 29. Insulation blanket |

WIRING SCHEMATIC/DIAGRAM

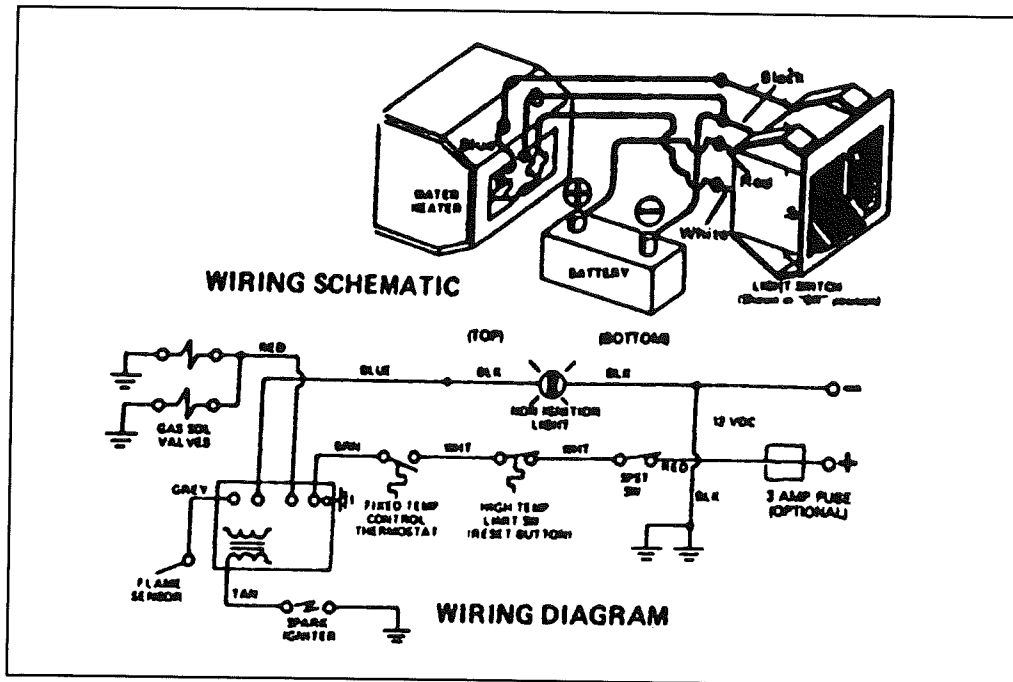

Removal

In order to remove the water heater, access must be gained to the water lines on the back of the heater. The carpeted panel next to the panel is only held in with about three screws - two in the top and one in the bottom corner. They can be difficult to see buried in the nap of the carpet, but if you feel with your finger tips you won't have any problem finding them. Once you have access to the lines the removal is basic:

1. Turn off LP gas at the bottles.
2. Disconnect city water or turn off water pump.
3. Remove drain plug in the face of the heater and open a faucet so water will drain.
4. Mark and disconnect wires if it has electronic ignition.
5. Remove perimeter screws around the face of the heater.
6. Use a putty knife or similar tool to break the seal between the water heater and the side of the trailer. Be careful not to damage paint.
7. After heater has drained remove water lines next to toilet.
8. Remove gas line.
9. Work the heater side to side as you are pulling out.

WARNING: Be sure to check the gas line connection with soapy water when replacing.

HIGH VOLUME ROOF VENT (OPTIONAL)

Manufacturer: FAN-TASTIC VENT CORP.
4349 S. Dort Hwy.
Burton, MI 48529
1-313-742-0330
1-800-521-0298

The optional high-volume roof vent system is designed to quickly exhaust stale, hot air and draw in fresh air. It's great to use when the outside temperature really doesn't call for air conditioning, but heat has built up in your coach.

OPERATING INSTRUCTIONS:

- 1) Open dome approx. 3" or more (ceiling fan has a built in safety switch that will not allow motor to operate unless dome is partially open).
- 2) Turn 3- speed knob to desired performance lever (3-Low, 2-Medium, 1-High, O-Off).
- 3) Open a window or door for airflow.
- 4) Source of airflow is determined by the window(s) or door(s) opened. For best results, close all roof vents and open 1 (one) window the greatest distance from your Fan-Tastic Vent ceiling fan.

CAUTION: Never place Lindeen™ or a like cover over ceiling fan. Greatly restricted airflow & increased sound levels will occur.

WHEN EQUIPPED WITH REVERSE SWITCH

- 1) Turn fan motor off by:
 - a) Setting 3-speed switch to "O" - OFF.
 - b) Closing Dome.
 - c) Selecting center position on IN/OUT rocker switch.
- 2) Wait for fan blade to stop.
- 3) Select IN position, brings air from the roof area into your coach (pressurizes inside).
- 4) Or select OUT position, brings air in through any or all openings in coach and exhausts through the roof.
- 5) Turn fan motor On.

WHEN EQUIPPED WITH THERMOSTAT:

- 1) Follow "Operating Instructions: 1 thru 4.
- 2) Select desired temperature or comfort level on thermostat. Fan motor will now start & stop automatically as interior temperature of coach exceeds or drops below selected level.

NOTE: Fan motor will not start if temperature selected is warmer than interior temperature of coach.

CLEANING INSTRUCTIONS:

- 1) Turn fan motor Off.
- 2) Remove 8 painted flathead phillips screws around perimeter of screen insert only.
- 3) Clean screen with soap & water solution and reinstall.

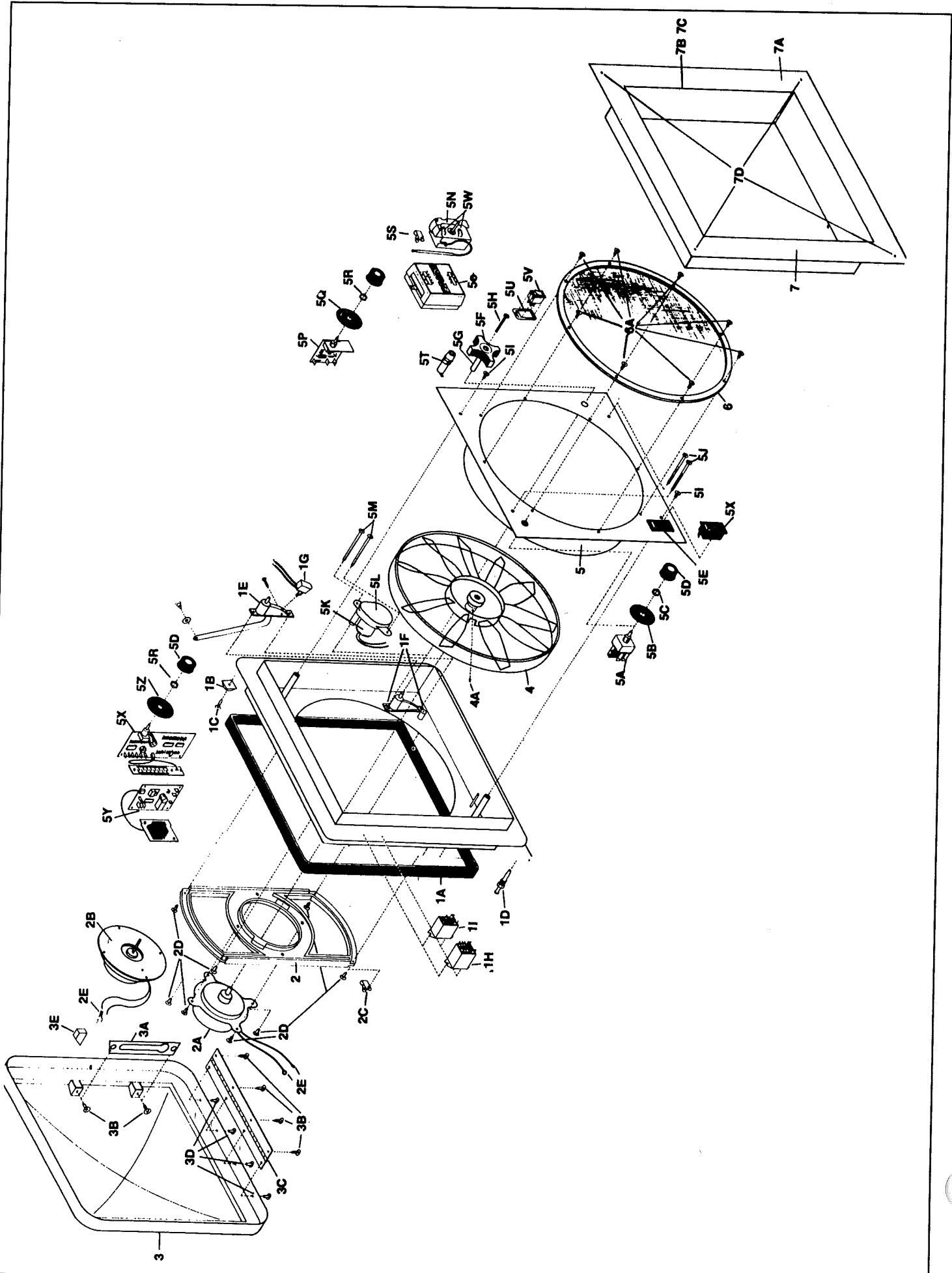

	#1	#1010-81	MAIN BASE
(4.5)	#1	#1144-09	EPDM BULB SEAL
	#1B	#1024-81	ALIGNMENT SPACER
	#1C	#1025-05	#8 x 5/8 F.H.PH. t/s ZINC
	#1D	#1122-05	JAMB SWITCH #9251 - C.H.
	#1E	#2011-05	6" LIFT ARM -w/RIV. & BUSHING
(2)	#1F	#1012-05	#10 x 1/2" P.H. PH. p/s - ZINC
(2)	#1G	#2053-09	P-267T-1A-RD CARLING LIMIT
	#1H	#2052-00	LYZF - DC - 12 - OMRON
	#11	#9002-09	G4W -11123 - 95 - TVB - DC - 12 OMRON
	#2	#1015-00	"H" MOTOR MOUNT
	#2A	#4017-09	MOTOR - PM3491x - BLK - 1600 RPM
	#2B	#1017-03	MOTOR-#31153-1400RPM-CSA
	#2C	#1019-81	HEYCO - CCL 1/8 - #3302 CLAMP
(8)	#2D	#1016-05	#8 x 1/2 P.H. PH. t/s -ZINC
	#2E	#1121-05	B3R - 56 - RING CONNECTOR
	#3	#1020-19	DOME-SMOKE
	#3A	#1023-05	DOME SLIDE - GALVANIZED
(6)	#3B	#1016-05	#8 x 1/2 P.H. PH. t/s - ZINC
	#3C	#1021-05	#1260A - HINGE - ALUMINUM
(4)	#3D	#1022-05	5/32 x 1/4 x 5/16 "o" RIVET ZINC
	#3E	#2018-81	DOME WEDGE - WHITE NYLON
	#4	#1138-00	FAN BLADE - 12" CLR.
	#4A		FAN BLADE SET SCREW
	#5	#1030-	SCREEN ASSEMBLY COLORED
	#5A	#1031-05	3-SPEED SWITCH #3K754
	#5B	#1033-09	DIAL LABEL - BLK. POLY
	#5C	#1032-05	NUT - 7/16 x 28 UNEF - ZINC
	#5D	#1034-09	KNOB - SOFT TOUCH #PT-6-P
	#5E	#9001-09	DPDT - HOT STAMPED w/CROSS
	#5F	#1140-09	KNOB - 1741Z - BLACK
	#5G	#2143-05	EXTENSION 1 1/8 - ZINC
	#5H	#1142-05	8-32 x1 3/4 P.H. PH. m/s ZINC
(2)	#5I	#1038-	#88 x 3/8" F.H. PH t/s - COLOR
(2)	#5J	#1039-	#8 x 2 3/4" F.H. PH. w/s - COLOR
	#5K	#6050-05	DOME LIFT MOTOR - #200.0262A
	#5L	#6035-	MOTOR CAP - COLORED
(2)	#5M	#1039-	#8 x 2 3/4 F.H. PH. w/s - COLOR
	#5N	#9006-05	BT THERMO #3301B
	#5P	#9015-90	SST THERMO #00-00127-000
	#5Q	#9009-09	LABEL - COOLER - BLACK
	#5R	#1032-05	NUT - 7/16 x 28 UNEF - ZINC
	#5S	#1018-81	BT CLAMP - CCL 1/4 - #3304
	#5T	#9017-00	FUSE #312010 - 10A - FLTW*
	#5T	#9018-09	FUSE HOLDER #345602 - FLTW*
	#5U		LABEL OVERRIDE/NORMAL
	#5V		B-2-1 8 GOLD - SPST-SGMA
(2)	#5W	#9008-05	6 - 32 x 1/4 F.H. PH. m/s - ZINC
	#5X		SPST w/ON/OFF LABEL
	#5e-	#9005-39	RBT. SHW w/OFF WALL THERMO
	#6	#1035-	SCREEN RING w/ALUM. WIRE - COLOR
(8)	#6A	#1038-	8B x 3/8" F.H. PH. t/s -COLORED
	#7	#1040-	INTERIOR GARNISH - 3" MAX. - COLOR
	#7A	#9024-81	INTERIOR GARNISH - 4" MAX. - COLOR
	#7B	#9019-00	OAK STYLE - FINISHED
	#7C	#9020-00	OAK RETURN PANEL - ANY SIZE
	#7D	#9010-	#6 x 3/4 F.H. PH. t/s - COLORED

NOTES

INDEX

- Air ConditionerI-1
Antenna.....H-25, H-28
Automotive Fuses.....H-2, H-9
Auxiliary Start Switch.....B-4
- Battery.....H-1
Battery Disconnect, Knife SwitchH-2
Black-Tank Flush.....G-12, G-19
Bottled GasG-1
By-Pass ValvesG-6, G-17
- Cab Seats.....B-4
CapacitiesJ-1
Camping.....D-1
CarpetF-3
CautionIntroduction
ChairsF-1
ChassisC-1
Circuit Breakers.....H-2, H-32
Cleaning Codes.....F-2
Cleaning, ExteriorE-1
CondensationD-3
Control Panel.....G-18, H-21
ConverterH-2
Counter Areas.....F-3
CurtainsF-2
- Dash Air conditioner.....C-2
Dash InstrumentsB-3, B-4
DimensionsJ-1
DinetteF-1
Door LockB-4, E-1
Drain Hose.....G-19
Drain LinesG-24
Drain Valves.....G-16
Drapes.....F-2
DrawersF-3
Driving.....B-1
- Electrical SystemH-1
Electric Cord.....H-29
Escape WindowD-1
Extended StayD-4
Exterior.....E-1
- FaucetsG-14
Fabrics, Cleaning.....F-2
Filter, WaterG-6, G-13
Flood LightB-4
FurnaceI-11
FusesH-9, H-13
- Gas Lines, LP.....G-4
Gas, LPD-2, G-1
Gate Valve.....G-25
Gauges.....B-3
GeneratorB-4, H-29
Ground Fault InterrupterH-29
GVWRJ-1
- Hitch LoadB-5
Humidity.....D-3
- InteriorF-1
Inflation PressureJ-1
Isolator.....H-2, H-4
- Keyless EntryE-3
Knife Switch.....H-4
- Lavatory, CleaningF-4
LevelingD-4
Leveling JacksD-2
Lights, CeilingH-1
LocksE-1
LoungeF-1
LPG System.....G-1
LP Leak TestD-2
- Maintenance Schedule.....A-7
Monitor PanelG-18, H-21
Mirrors, Remove ControlH-20

Overnight Stop.....	D-2	Towing	B-5
Plastics, Cleaning	F-4	TV Antenna	H-25
Plumbing.....	G- 1	Upholstery	F-2
Power Cord	H-29	Vent, Power	I-72
Power Seats.....	B-4	Ventilation.....	D-3
Priority Switch	H-33, I-1	Washing/Waxing	E-1
Range/Oven.....	I-45	Warning	Intro.
Reporting Safety Defects.....	A-6	Warranty	A-1, A-4
Refrigerator	I-27	Warranty Transfer	A-3
Roof Vent.....	I-58	Warranty Exclusions.....	A-1
Safety Defects, Reporting.....	A-6	Water Filter	G-6, G-13
Safety.....	B-1, D-1, D-3, G-2	Water Heater.....	I-51
Search Lights	B-4	Water Hookup.....	G-12
Seat Belts	B-2	Water Pump	G-6
Serial Number	E-2	Water System	G-5
Service	A-5	Wheel Base	J-1
Sewer Hose	D-4, G-19	Windshield Wiper.....	C-7, C-35
Shades.....	F-3	Winterizing	G-16
Shower Stall	F-4	Winter Traveling.....	D-2
Sinks	F-4	Wiring, 12 Volt.....	H-2
Smoke Detector	D-1	Wiring Diagrams, 12 Volt.....	H-3
Sofa	F- 1	Wiring, 110 Volt.....	H-29
Specifications	J- 1	Wiring Diagram, 110 Volt.....	H-31
Step	C-8, C-36		
Table.....	F-1		
Tank Capacities	J-1		
Tank Drain	D-4, G-19		
Tank Sewage.....	G-13, G-18		
Tank Water.....	G-6, G-12		
Tank LPG.....	G-1		
Tires, Pressure	J-1		
Toilet.....	G-20		