

OWNER'S MANUAL

89

LAND YACHT

TRAILER

INTRODUCTION

Welcome to the Airstream family of RV owners.

Recreational Vehicle....a way of traveling to places with a relaxing and refreshing atmosphere.

The Owner's Manual is designed to help you learn about the systems and features of the Land Yacht Travel Trailer. When you purchased the trailer your dealer showed you many of the conveniences of the Land Yacht. So many in fact we realize all the information cannot be retained. This manual should refresh your memory to allow the trailer to be as easy to use as possible.

The manual provides basic information on appliances, such as the furnace, water heater and refrigerator. More detailed information is supplied by the manufacturers of the appliances, and can be found in your Owner's Packet.

All information is based on the product being built at the time of publication approval. Land Yacht will make changes within a model year to improve the vehicle or due to vendor changes. If a particular feature is not covered in the manual check with your dealer. He will be more than happy to explain the operation of the new feature.

Throughout this manual CAUTION and WARNING notations are used. Failure to observe "CAUTION" can damage equipment. "WARNING" notes the possibility of personal injury if not observed.

NOTE: If and when new material and production techniques are developed which can improve the quality of its product, or material substitutions are necessary due to availability, Airstream reserves the right to make such changes.

***1000 MILE CHECK OR 60 DAY CHECKOUT**

AUTHORIZATION CARD

This card entitles you, under the exclusive Airstream Certified Performance Checkout Program, to a 1000 Mile (or 60 day.....whichever comes first) Performance Check of your Land Yacht Trailer.

***After delivery of your trailer.**

TABLE OF CONTENTS

A. WARRANTY AND SERVICE

- Warranty
- Warranty Explanation
- Service
- Maintenance Schedule
- Maintenance Parts & Supplies

B. TOWING

- Tow Vehicles
- Hitching Up
- Loading
- Towing
- Accessories for Towing
- Pre-Travel Check List

C. CAMPING

- Camping Safety
- Camping Locations
- Leveling & Stabilizing
- Hook Ups
- Winter Traveling

D. EXTERIOR

- Identification
- Care
- Storage & Main Doors
- Chassis
- Awnings

E. INTERIOR FURNISHINGS & ACCESSORIES

- Lounge Conversion
- Table Conversion
- Cleaning (Interior)
- Storage Areas
- Condensation
- Windows & Vents
- Accessories, Interior

F. PLUMBING

LP (Liquid Petroleum) Gas
Water
Drainage

G. ELECTRICAL

Power Convertor
12 Volt
110 Volt
Circuit Breakers & Fuses
Monitor Panel
Bulbs and Fuses
Trouble Shooting
Wiring Diagrams

H. APPLIANCES

Air Conditioner
Furnace
Range
Refrigerator
Water Heater

I. SPECIFICATIONS

AIRSTREAM, INC.
LIMITED WARRANTY
1989 LAND YACHT TRAVEL TRAILER

WARRANTY COVERAGE

When you buy a new LAND YACHT TRAVEL TRAILER from an authorized LAND YACHT dealer, Airstream, Inc. warrants the trailer from defects in material and workmanship as follows:

WARRANTY PERIOD

This warranty extends for a period of one year from the date of original retail purchase.

ITEMS COVERED

Any part of the trailer or any component equipment installed by the factory is covered by the warranty except the following items which are not covered:

- * Tires
- * Battery
- * Fuses and light bulbs
- * Radio and cassette players

The tire, battery and radio/cassette warranties will be handled by their respective service points and according to their written policy. This limited warranty does not include failure caused by accident, abuse, normal wear, overload or any cause not attributable to a defect in original material or workmanship of the trailer or component equipment as installed by the factory.

LIMITATION OF IMPLIED WARRANTIES

All warranties of merchantability and fitness for a particular purpose, whether written or oral, express or implied, shall extend only for a period of one year from the date of original purchase. There are no other warranties which extend beyond those described on the face hereof and expressly excludes conditions resulting from normal wear, accident, abuse, exposure or overload. Some states do not allow limitation on how long an implied warranty lasts, so the above limitation may not apply to you.

AIRSTREAM'S RESPONSIBILITY

The Land Yacht Limited Warranty applies for a period of one year from the date of original purchase, and the applicable date of all warranties is that indicated on the Owner's Identification Card. Defects in items covered under this warranty will be corrected without cost upon the return at the owner's expense of the trailer or defective part to an authorized Land Yacht dealer.

CARE AND MAINTENANCE

This warranty covers only defective material and/or workmanship; adjustments and checking are excluded. All adjustments are made at the factory prior to shipment, and rechecked by the dealer prior to delivery to the customer. An additional check up, including adjustments, is given at the 1,000 mile or 60 day inspection. Adjustments thereafter become a customer responsibility.

Each Land Yacht exterior (not including the underside) is sprayed with paint to prevent oxidation. The application is covered by the one year warranty against peeling. Prolonged exposure to salt air or industrial fall-out will permit penetration through the coating material, causing damage to the exterior finish. Since Airstream, Inc. has no control over these conditions, it is necessary for the owner to wash and maintain the trailer as instructed in the Owner's Manual.

The owner is also responsible for following all recommendations, instructions and precautions contained in the Owner's Manual and the individual manuals furnished by the appliance manufacturers.

INSTALLATIONS NOT COVERED

Airstream, Inc. cannot, however, and does not accept any responsibility in connection with any of its travel trailers for additional equipment or accessories installed at any dealership or other place of business, or by any other party. Such installation of equipment or accessories by any other party will not be covered by the terms of this warranty.

IF REPAIRS ARE NEEDED

If your trailer needs repairs under the terms of the Land Yacht Limited Warranty, you should:

1. Take your trailer to your selling dealer or other authorized Land Yacht dealer.

2. If the dealer is incapable of making the repair, request that he contact the Service Administration Department at Airstream, Inc. for technical assistance.
3. If repairs are still not made, the customer should contact Airstream, Inc. 419 W. Pike Street, Jackson Center, Ohio 45334, Attention: Owner Relations Department and furnish the following information:
 - * The complete serial number of the trailer.
 - * Date of original purchase.
 - * Selling Dealer.
 - * Nature of service problem and steps or service which have been performed. (The owner may be directed to another dealer at the owner's expense.)
4. If, after taking the above steps, repairs are still not complete, the Land Yacht owner may request the trailer be allowed to be brought to the Factory Service Center at the owner's expense.

DEALER REPRESENTATION EXCLUDED

The full extent of Land Yacht's Limited Warranty is set forth in detail in this folder, and in the Explanation of Land Yacht Limited Warranty covered in the Land Yacht Trailer Owner's Manual. Airstream, Inc. will not be responsible for additional representations or implied warranties made by any of its dealers to the extent those representations are not a part of, or are contrary to, the terms and conditions of the Land Yacht Limited Warranty.

CONSEQUENTIAL AND INCIDENTAL DAMAGES

Airstream, Inc. will not be responsible for any consequential or incidental expenses or damages resulting from a defect. Incidental expenses include, but are not limited to, travel expenses, gasoline, oil, lodging, meals, telephone tolls, loss of work and loss of use of the trailer. Some examples of consequential damages would be: stained curtains due to rain leaks or delaminated floor caused by a plumbing leak. Some states do not allow the exclusion or limitation of incidental or consequential damages, so the above limitation or exclusion may not apply to you.

WARRANTY TRANSFER

This limited warranty is transferable to subsequent owners for the duration of the warranty period. Warranty transfer application forms are available from your dealer or the Airstream, Inc. Service Administration Department.

CHANGES IN DESIGN

Airstream, Inc. reserves the right to make changes in design and improvements upon its product without imposing any obligation upon itself to install the same upon its products theretofore manufactured.

This warranty gives you specific legal rights, and you may also have other rights which vary from state to state.

Thor Industries
Airstream, Inc.
419 West Pike
Jackson Center, Ohio 45334

SERVICE

Please contact your dealer for an appointment if you need service. Normally you will find northern dealers will be busiest in the summer months so you should contact them as soon as you are aware of a problem and discuss arrangements with the service manager. Southern dealers, especially those in Arizona, California and Florida, will have their busiest season during the winter months.

Many experienced RVers will take their trailer out for a weekend of camping a month or so before an extensive trip. This "shake down" gives them a chance to thoroughly check out the unit and have any repairs made before they "hit the road". You may also discover some of the best camping is not that far from home.

If warranty service is required make sure you take your Identification Card with you. The dealer must have the imprint of your card and your signature to obtain his reimbursement from the factory. Keep your list of service requirements concise and complete. Service Managers have many customers to service. If you keep adding to your list as the work is being done, scheduling for the service manager can be a real nightmare. Always check out the repairs immediately, and inform the service manager of any discrepancies.

When traveling far from your dealer and service is required, refer to the dealer list provided with your new trailer. We would suggest you obtain a new list from your dealer on a yearly basis since the list consistently changes. Always call ahead for service. Even if you are only an hour's driving time from a dealer this call can make the difference in whether you can be serviced the same day or will have to wait.

If you have a service problem that you can't get worked out with the service manager contact the owner or general manager of the dealership and discuss the situation with them. If you still cannot obtain a solution write to the Customer Relations Department, Airstream, Inc., 419 West Pike, Jackson Center, Ohio 45334 or phone 513-596-6111. Provide the Customer Relations Department with your name, address, serial number of the trailer, and purchase date. If your trailer was purchased under the name of a business that information should also be provided.

Service is available at the Factory Service Center. To make an appointment contact:

Service Coordinator
Airstream Factory Service Center
419 West Pike
Jackson Center, Ohio 45334
Phone: 513-596-6111

MAINTENANCE SCHEDULE

NOTE: (See appliance manufacturer's literature for further information.)

EVERY 1,000 MILES OR 30 DAYS

Escape window	Check operation of latches and upper hinge.
Battery	Check water level.
Smoke alarm	Test and replace battery as required.
Tires	Check tire pressure (50 psi).
Hitch	Check for loose bolts or unusual wear.
GFI circuit breaker	Test and record.

WARNING: On new trailers check lug bolts every 200 miles for first 100 miles. Torque 90-95 ft. lbs.

EVERY 5,000 MILES OR 90 DAYS

Exterior door locks	Lubricate with dry graphite.
Exterior hinges	Lubricate with light household oil.
LPG hold down latch	Spray latch with WD-40 or equivalent.
LPG regulator	Check bottom vent for obstructions.
Main door striker pocket	Coat with paraffin.
Wheel lug bolts	Torque to 90-95 ft. lbs.
Break away switch	Pull pin and lubricate with household oil.
9-way plugs	Spray with contact <u>cleaner</u> .
Hitch ball latch	Lubricate with non-detergent motor oil.
Hitch ball	Lubricate with hitch ball lube or wheel bearing grease.

MAINTENANCE SCHEDULE CONTINUED

EVERY 10,000 MILES OR 6 MONTHS

Brakes	Inspect, adjust or replace as necessary
Wheel Bearings	Clean and repack.
Tires	Inspect and rotate.
Spare Tire Carrier	Lubricate moving parts.
Seals, Windows & Door	Clean with mild detergent and coat with "Slipicone".
TV Antenna	Lubricate all moving parts with WD-40.
Exterior	Wax
Escape Window	Lubricate latches with WD-40.

EVERY YEAR

Battery	Clean, neutralize and coat terminals with petroleum jelly.
A-Frame, Step	Wire brush and paint A-frame, step, rear frame.
LPG Bottles	Have purged by LPG supplier.
Seams	Reseal exterior seams, windows, lights, and vents with Kool Seal - Aluminum.

SUGGESTED MAINTENANCE PARTS AND LUBRICANTS

BULBS

Exterior Convenience Lights	1003
Taillight	2057
Back-Up	1156
Clearance Lights	194
License Plate Light	168
Step Light (Assist Handle)	1141 (Amber)
Interior Ceiling Lights (Single and Double)	1141
Refrigerator	B-3

12 VOLT FUSES

12 Volt Distribution Panel	20 Amp GM Automotive Style Fuses
Entertainment Center	3 Amp, FKD

MISCELLANEOUS

- Water Hose Gaskets
- Extra Hair Pin Clips for Hitch
- Dry Graphite
- Oil can with 30 weight non-detergent oil
- Light household type oil
- Hitch ball lube (may use wheel bearing grease)
- Wheel bearing grease
- Grease seals
- WD-40 or equivalent aerosol lubricant
- Spray contact cleaner
- Sealer (Kool Seal - Aluminum, Sikaflex - Aluminum)

TOW CAR EQUIPMENT

If you plan to buy a new vehicle to tow your trailer we suggest that you include in your purchase the trailer towing options offered by most automobile manufacturers. These include such things as heavy duty alternator and radiator, heavy duty springs* and shock absorbers, automatic transmission cooler, heavy duty fan and flasher unit and others, depending on the make of the vehicle.

Transmissions may be manual or automatic, but an automatic transmission may prolong your car's engine life and generally does a better job of controlling engine loads than the average driver using a manual shift.

Having adequate power is very important when considering the purchase of a new car or the trailer towing capability of your present one. Emission controls that are required by the Federal Government have reduced overall engine power.

American car manufacturers realize more than 30% of the cars they sell will be used for towing some type of trailer. The car dealers are provided with guidelines to use when helping a customer decide on a tow vehicle. The guidelines are not just determined by the power output of the engine. The gear ratio of the differential is also a very important part of the guideline.

Inspect your vehicle's hitch regularly for loose bolts or nuts, cracked welds, loose ball mounts, worn parts, etc.

New trailerists often carry more food and other supplies than really needed. Remember that every item you take along is one more thing to stow and adds weight to the total load you must pull. Consolidate items in shelves, lockers, and in the refrigerator. It is better to have one full and one empty locker than two half empty ones. Special care must be taken not to overload the front and rear ends of the trailer.

** NOTE: Be realistic when ordering heavy duty springs. Only springs heavy enough to support your loaded vehicle (not including trailer) are necessary. Too harsh of spring rate will only shorten the life of the tow vehicle, trailer and make your journeys less enjoyable.*

ELECTRIC BRAKES

The brakes are operated by 12 volt current from your car and MUST BE HOOKED UP SO THAT YOU HAVE AN INTEGRAL SYSTEM WITH YOUR CAR BRAKES. To prevent problems and insure satisfactory braking action, install a Kelsey Hayes Controller (or equivalent) in line with the controller in your car.

A Kelsey Hayes Controller (or equivalent) installed in your car will synchronize the trailer brakes with your car brakes. It is designed to apply the trailer brakes with your car brakes.

The controller handle adjustment affects the rate of application of the trailer brakes. This adjustment has no bearing on the maximum braking capacity of the trailer brakes. Because of the wide variety of towing vehicles and trailers it is necessary to balance the trailer brakes with the towing vehicle brakes to provide for a safe, comfortable stop. This adjustment should be made to provide for a slight lead of the trailer brakes over the tow vehicle brakes. Turning the handle clockwise will decrease the rate of application of the trailer brakes, while counterclockwise will increase the rate of application. When the desired setting is reached, the controller will hold the adjustment, but may be varied at any time by rotating the handle as described above. After this adjustment there should be no sensation of the trailer pushing the car during a stop, nor should there be an excessive sensation of the trailer pulling the car during a stop.

Due to normal brake lining wear the brakes and the controller setting should be checked and readjusted, if necessary, during the trailer manufacturer's recommended inspection intervals.

NOTE: Brake lining adjustment should be periodically checked (fully) to be sure trailer brakes are in the same adjustment as the automobile's.

Properly set these adjustments will provide for safe comfortable stops. They will also help assure optimum brake and tire life for both the tow vehicle and the trailer.

In the EVENT OF AN ACCIDENTAL SEPARATION OF the tow car and trailer, THE BREAKAWAY SWITCH will set and lock the trailer brakes for a sufficient length of time to stop the trailer, providing a battery is hooked up in the trailer. The switch is activated when the small pin in the front of the unit is pulled out by the wire attached to it and to the car. THIS PIN SHOULD BE PULLED OUT, LUBRICATED WITH LIGHT HOUSEHOLD OIL AND REPLACED EVERY 90 DAYS.

To prevent corrosion within the breakaway switch, pull the switch's pin straight forward and spray the inside of the switch through the hole with an electric contact cleaner (such as Spra-Kleen) and re-insert pin. A drop of light household oil on the groove near the

base of the pin will allow the pin to operate freely. WHEN THE TRAILER IS CONNECTED TO THE TOW CAR, THE BREAKAWAY SWITCH LOOP SHOULD BE ATTACHED TO THE PERMANENT FRAME OF YOUR HITCH. When disconnecting trailer from tow car, remove wire loop from the frame. DO NOT REMOVE PIN FROM SWITCH BECAUSE THIS WILL APPLY THE TRAILER BRAKES.

CAUTION: DO NOT USE BREAKAWAY SWITCH FOR PARKING BRAKE.

MAIN CHARGE CIRCUIT AND BRAKE CIRCUIT

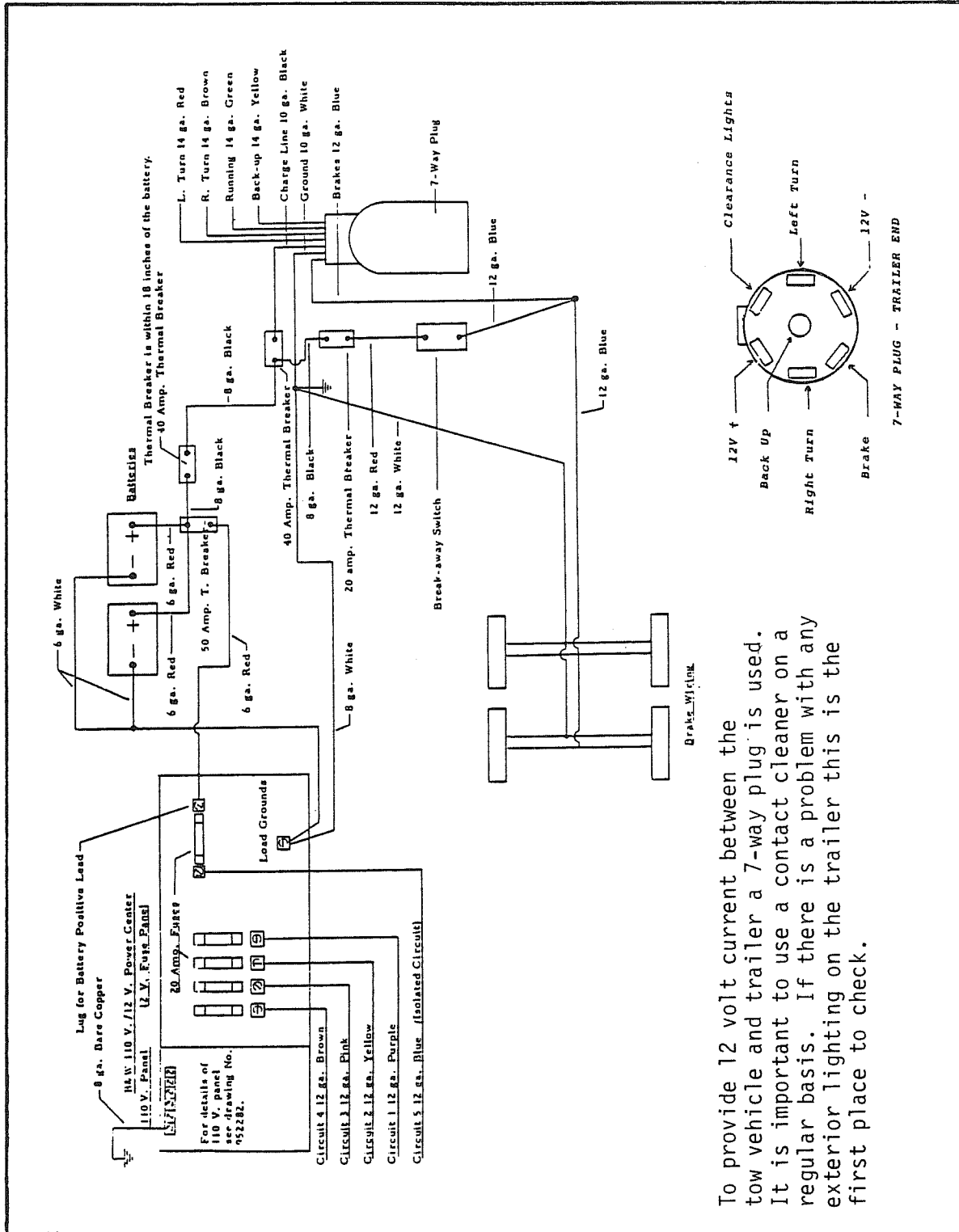

To provide 12 volt current between the tow vehicle and trailer a 7-way plug is used. It is important to use a contact cleaner on a regular basis. If there is a problem with any exterior lighting on the trailer this is the first place to check.

LOADING

There are two important factors to keep in mind when loading your trailer. Total weight and balance.

On the roadside front corner of your trailer is a manufacturing data plate listing three weights on dual axle trailers.

G.V.W.R.	Gross Vehicle Weight Rating	Total Weight Capacity
G.A.W.R. (Front)	Gross Axle Weight Rating	Front Axle Capacity
G.A.W.R. (Rear)	Gross Axle Weight Rating	Rear Axle Capacity

WARNING: The gross weight rating is the maximum load carrying capacity allowed by the vehicle or axles. DO NOT overload your vehicle.

At first glance it does not seem logical for the carrying capacity of the vehicle to exceed the total carrying capacity of both axles. The other weight bearing member, besides the axles, is the tongue.

To find the actual weight* of the trailer it must be weighed on scales. Scales capable of weighing your trailer may be found at grain elevators, stone quarries or at a state operated truck scales along the highway. If you are not sure of the location of scales in your area contact your local state highway patrol post for assistance.

The total cargo you can safely carry in the trailer is the difference between the weight of the trailer and the Gross Vehicle Weight Rating. For instance, if the GVWR on your trailer is 6,200 lbs. and the total weight of your trailer is 4,500 lbs., you could carry an additional 1,700 lbs. of water, clothes, utensils etc.

**NOTE: The dry weight is listed in the Specifications Section.*

When loading heavy objects such as tools, skillets, irons, boxes of canned goods, etc. keep them as low as possible - preferably on the floor. Try to hold additional weight behind the axle to a minimum.

WARNING: Never add items such as generators, heavy tool boxes or motorcycle racks to the back of the trailer. Weight behind the axle will tend to magnify any sway that may occur when passing trucks or in gusty wind. If a heavy generator is mounted on the rear bumper what may have been an almost unnoticeable sway turns into a severe sway you may not be able to control.

CAUTION: Damage to your trailer caused by mounting heavy objects on the rear is considered abuse, and is not covered by warranty.

WEIGHING YOUR TRAILER

The diagram below shows how to weigh the trailer on scales.

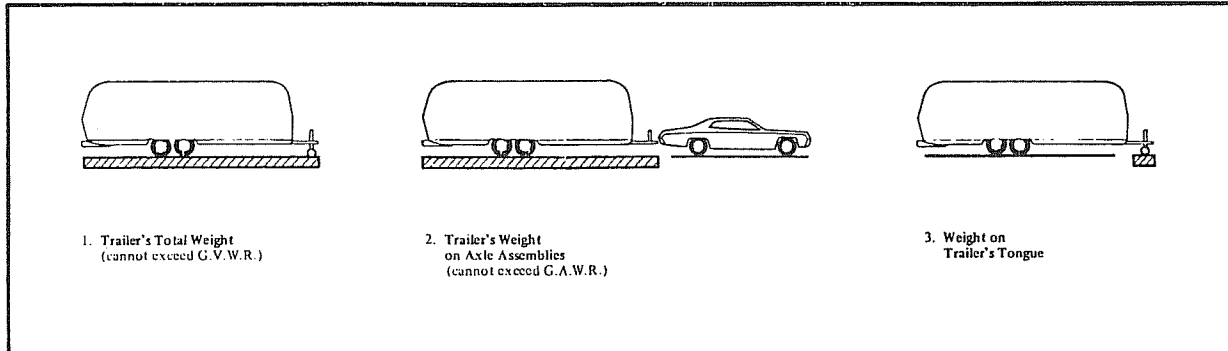

The allowable personal cargo, determined above, must be distributed in your trailer in such a manner that the Gross Axle Weight Rating is not exceeded.

To determine this is it necessary to load all of your allowable personal cargo (example above 1,700 lbs. total) and variable weights. Then hitch trailer to tow vehicle with load equalizing hitch properly adjusted as shown on the following pages.

Place trailer on scale with both axles only on scale (see 2). If the weight on the axles exceeds the axle system G.A.W.R. then some of the personal cargo must be redistributed forward in order to place some of this weight on the tongue.

The tongue weight should be between 10% - 15% of the trailer's total weight but must not exceed 1,000 lbs. Some tow vehicle manufacturers may restrict the amount of tongue load to a lower value. To determine tongue load, unhitch tow vehicle and place tongue hitch post on scale, (see 3). The trailer must be properly loaded as determined above, with your allowable personal cargo and variable weights.

A scale which has a lower weight limit than your tongue load, such as a bathroom scale, may be used to check the tongue weight by using the following method (see illustration).

Place a piece of wood of approximately the same thickness as the bathroom scales on the ground in line with the trailer hitch jack as shown. It should be so spaced that a short piece of pipe or other round piece will lay exactly one foot from the center line of the jack extension. Place the scales so that another round piece can be exactly two feet from the center line of the jack extension in the other direction. Place a 4 x 4 on the two round pieces and screw the jack extension down on the top of the 4 x 4 until the tongue of the trailer is supported by it. Multiply the scale reading by three. This will be the tongue weight of your trailer. If you exceed the capacity of the bathroom scales, increase the two foot dimension to three or four or more feet, but always multiply the scale reading by the total number of feet between the wood and scales.

CAUTION: BE SURE TRAILER IS LEVEL WHEN YOU READ SCALES.

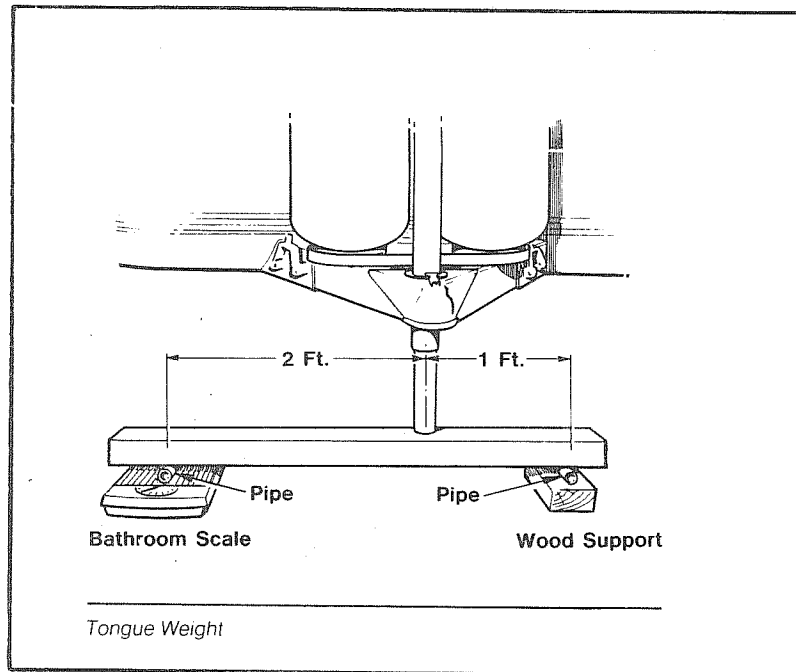

HITCHING UP

Hitching up your trailer is something that will become almost second nature with practice. The following section includes proper hitch load distribution and a procedure for hitching up.

The electric jack is strongly recommended for anyone who, for any reason, should not physically exert himself. Available as an option, the electric jack makes hitching and unhitching a much easier operation.

EQUALIZING HITCH LOAD DISTRIBUTION. When a trailer is hitched up properly to a tow vehicle with a load equalizing hitch, approximately 1/3 of the trailer's tongue weight will be on the trailer's axles and 2/3 will be transferred to the tow vehicle. 1/3 of this weight transfer will be carried by the front wheels and 1/3 by the rear wheels of the tow vehicle (see diagram). Thus, the tire loading of each wheel on the tow vehicle will be increased by 1/6 of the trailer's tongue weight. The tire air pressure of the tow vehicle should be increased to compensate for this additional weight. Refer to the vehicle's owners manual for this information.

EQUALIZING HITCH LOAD DISTRIBUTION

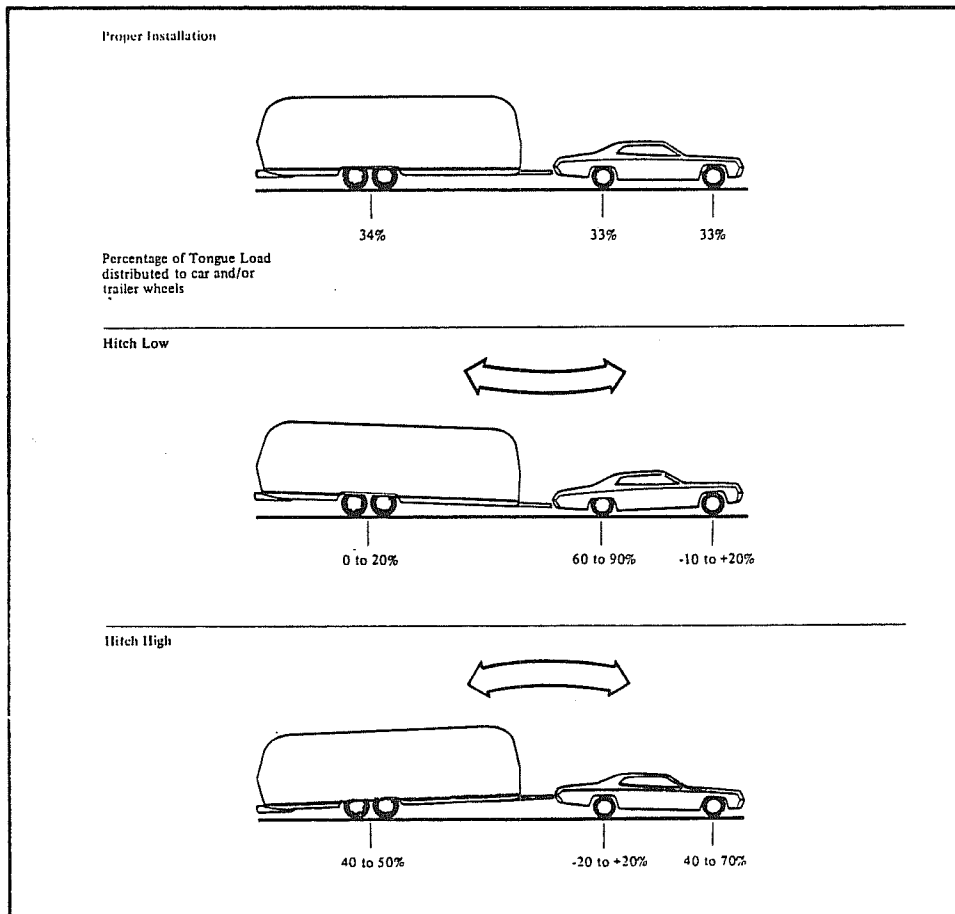

STEPS FOR HITCHING UP. Jack up the trailer hitch until there is clearance for the HITCH BALL to slide under, remove safety pin and raise the LOCKING LEVER. Back the car straight back to the hitch. (See Fig. 2). This can best be accomplished through the use of pre-arranged hand signals with the help of another person, but if you are hitching up by yourself we recommend the use of a HOOK-UP VIEW MIRROR.

Lower the trailer hitch onto the hitch ball. Then close the locking lever and insert safety pin. (See Fig. 3)

Now raise the trailer and car to the full height of the hitch jack (See Fig. 7) and then attach the LEVELING BARS. (See Fig. 4,5, & 6). Lower the car and trailer (See Fig. 7). The hitch ball should be level to slightly higher. Readjust leveling bars until this condition is correct, by increasing or decreasing length of chain engaged in "A" frame saddle bracket. Shorter chain raises hitch ball, longer chain lowers it. A level condition will result in the best balance for towing and steering control as the weight equalizing hitch distributes the hitch load. A low hitch ball increases tail wagging tendencies by lowering the nose of the trailer thus changing the center of support for the trailer and reducing the weight on the front wheels of the car. With proper hitch installation and hitching up, the bar should have a noticeable amount of deflection or bending. (See Fig. 8) A little practice with your rig will teach you how far to pull the bar, and you may wish to mark the chain links that match your rig.

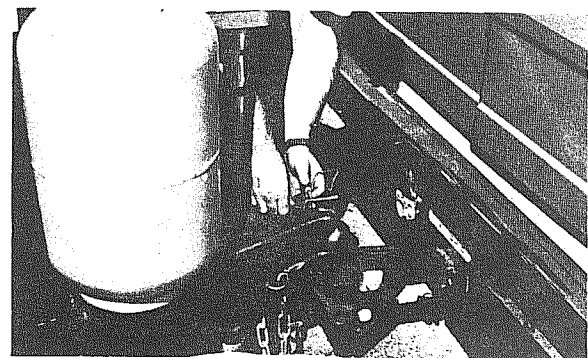
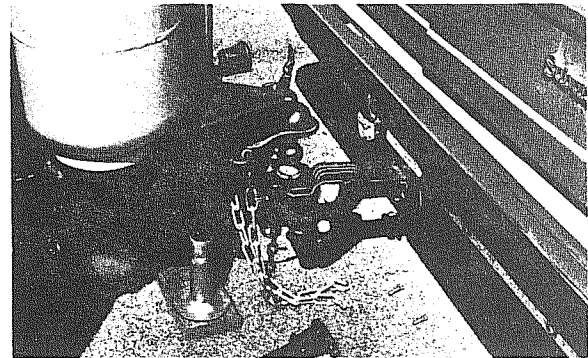
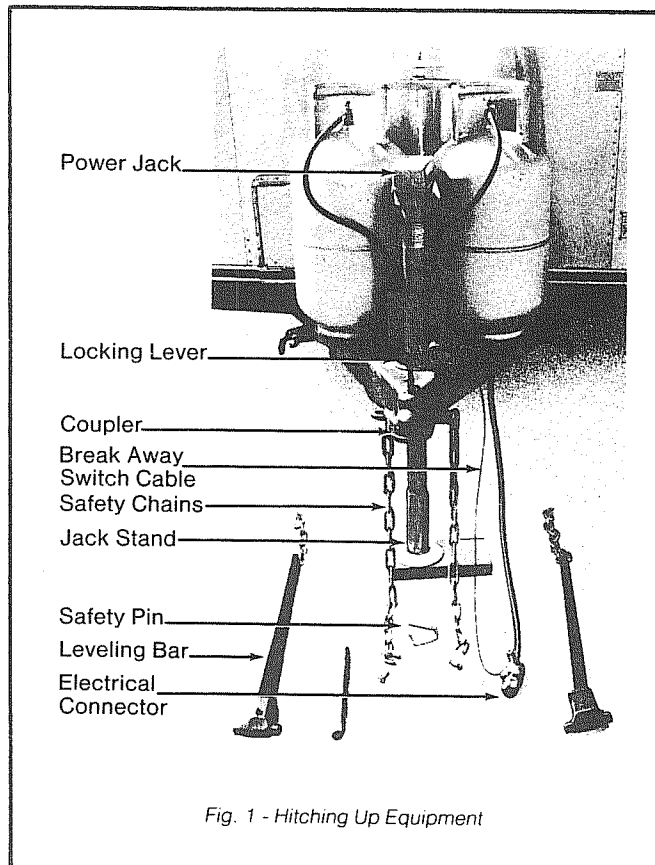

Always choose level ground for checking correct hook-up. For further information see hitch manufacturer's literature.

NOTE: If your car is equipped with adjustable load leveling air shocks, you must load the car first with typical luggage and passengers and bring it back to level. Then attach the trailer and adjust the load leveling bars. Otherwise the air shocks on your car will overload the rear wheels. Do not use air shocks to level car and trailer after hitching up.

The hitch ball on your car should be installed 1 inch higher than the trailer coupler to allow for the car to settle under the additional weight. Coupler height on the trailer is determined by leveling the trailer end to end then measuring from the ground to the top of the ball socket.

Attach the safety chains (See Fig. 10) to the welded portion of the hitch or the car's frame, but never to the removable ball mount. Cross the safety chains under the hitch.

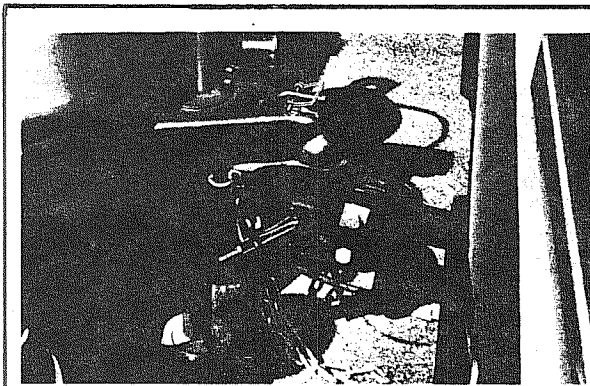

Fig. 4

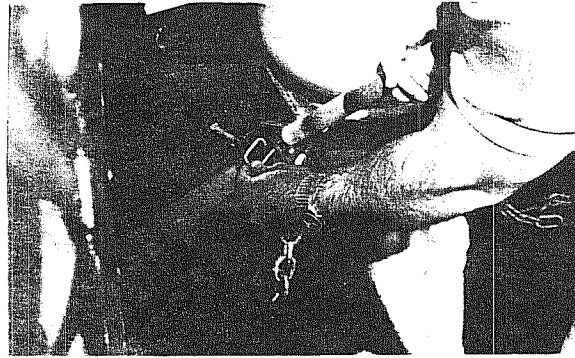

Fig. 6



Fig. 5

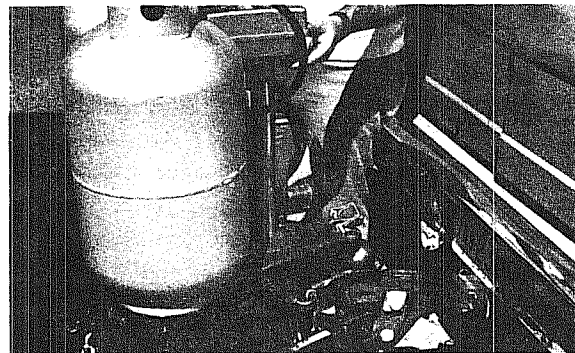

Fig. 7

CAUTION: Retract the hitch jack completely for maximum ground clearance. Remove the jack pad (See Fig. 12) and stow in the car's trunk along with leveling jack and other gear used when stopped. NEVER TOW YOUR TRAILER WITH THE JACK DOWN. Check that the fold-away step is up and that the main door is completely closed and LOCKED for towing. If it is not locked the constant vibration of travel may cause it to open with possible damage.

Move the rig ahead about 50 feet and test the trailer brakes, then check the ground for forgotten objects. Regularly check the condition of your tires, air pressure, and the tightness of the lug bolts.

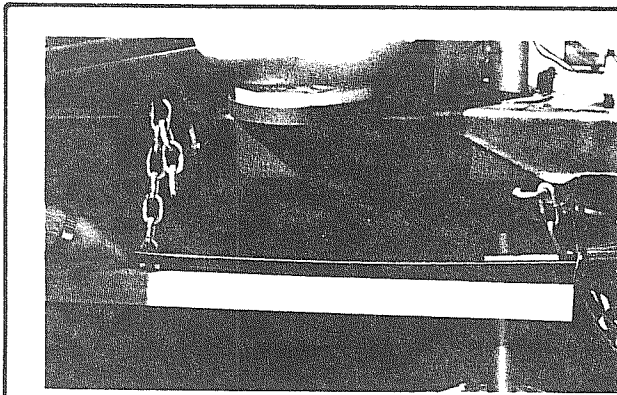

Fig 8

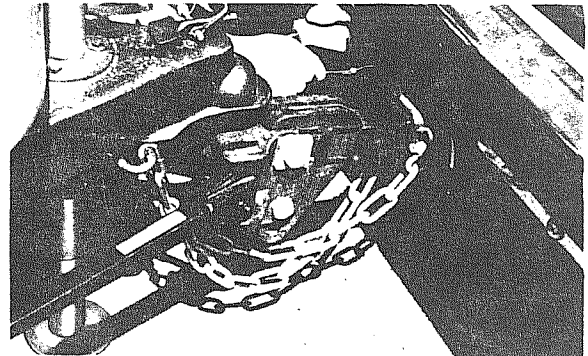

Fig 11

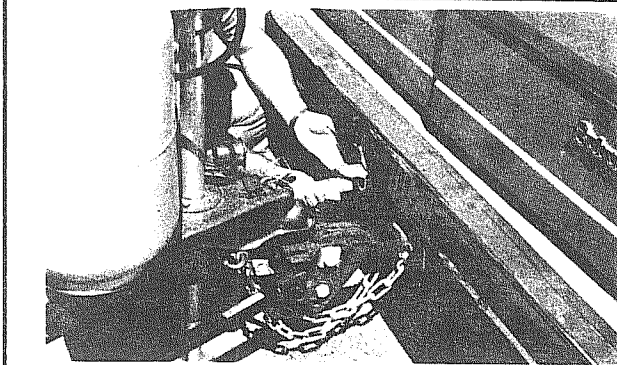

Fig 9

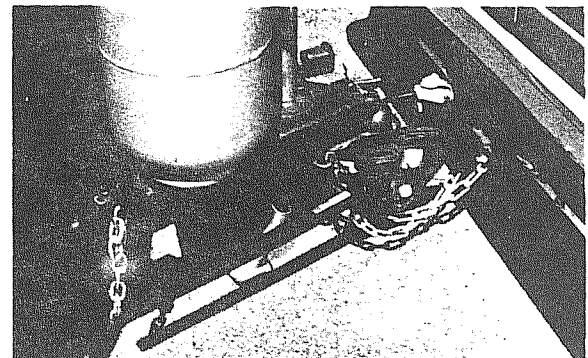

Fig 12



Fig 10

TOWING TIPS

We want every owner to be a safe and courteous driver. A few hours of towing practice in a large empty supermarket lot will make pulling your trailer over the road much easier. Line out two corners for left and right turns. You may also use these corners to practice backing and parking.

OBSERVE THAT THE TRACKS MADE BY THE TRAILER WHEELS ARE DISTINCTLY DIFFERENT FROM THOSE MADE BY THE CAR. Studying this will make it easier for you to correct mistakes. Truck or trailer type fender or door grip rear view mirrors are a must for maximum visibility and in most states they are required by law.

After thoroughly inspecting your hitch, brakes and tires you should be ready to tow. Check traffic, signal that you are about to pull away, and start slowly. Look often in your mirrors, and observe the action of the trailer, then carefully move into the proper lane of traffic. Remember that the trailer wheels will not follow the path of the car's wheels, therefore, WIDER TURNS ARE NECESSARY WHEN TURNING TO THE LEFT OR TO THE RIGHT.

ON FREEWAYS OR EXPRESSWAYS try to pick the lane you want, and stay in it. Always maintain plenty of space between you and the car ahead, at least the length of the car plus trailer for every ten miles per hour. Remember that in order to pass another vehicle you will need longer to accelerate. You must also allow for the length of the trailer when returning to the right hand lane.

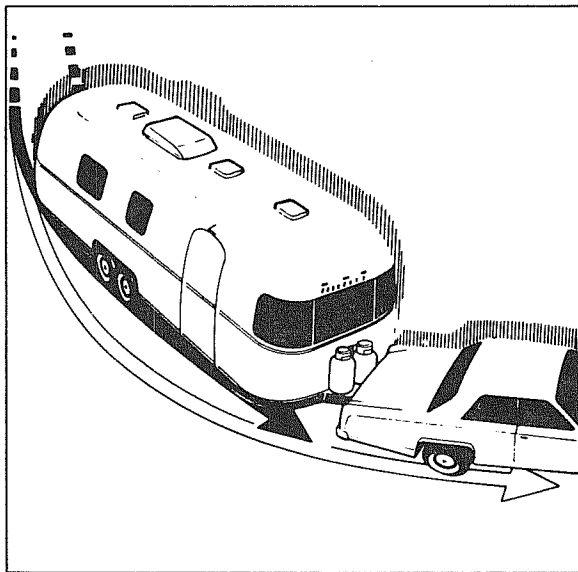

Tracking

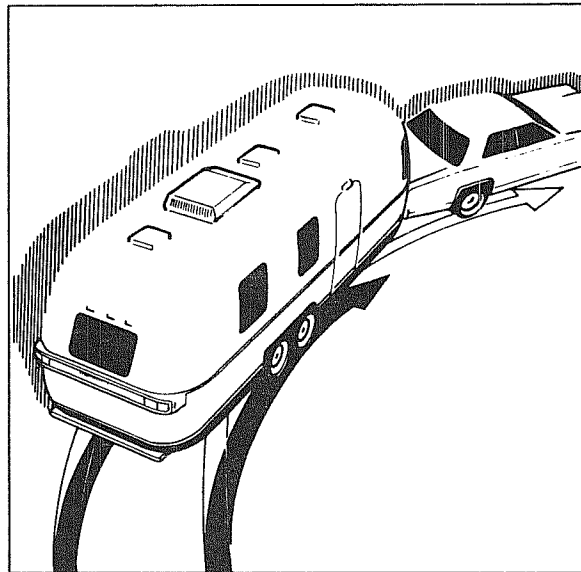

On a two lane road, cars will be lining up behind you because you travel at a lower speed. It is both courteous and sensible to signal, pull onto the shoulder, and let them pass. Your trailer is designed to be towed easily at any legal speed, so if you are not careful you may be inclined to forget it is there.

The BRAKE CONTROLLER is activated when you apply the brakes of the tow vehicle. Your car brakes will automatically apply the trailer brakes first when properly adjusted. This will help keep your car and trailer in a straight line and make you stop as if you were driving the car alone.

When trailering you might encounter a temporary cooling system overload during severe conditions such as hot days when pulling on a long grade, when slowing down after higher speed driving, or driving long idle periods in traffic jams. If the hot indicator light comes on, or the temperature gauge indicates overheat and you have your air conditioning turned on, turn it off. Pull over in a safe place and put on your emergency brake. Don't turn off the engine. Increase the engine idle speed. Lift the engine hood and check for fluid leaks at the radiator overflow outlet. Check to see that all drive belts are intact and the fan is turning. If you have a problem, have it fixed at the next opportunity. If there is no problem the light should go off or temperature should come down within one minute. Proceed on the highway a little slower. Ten minutes later resume normal driving.

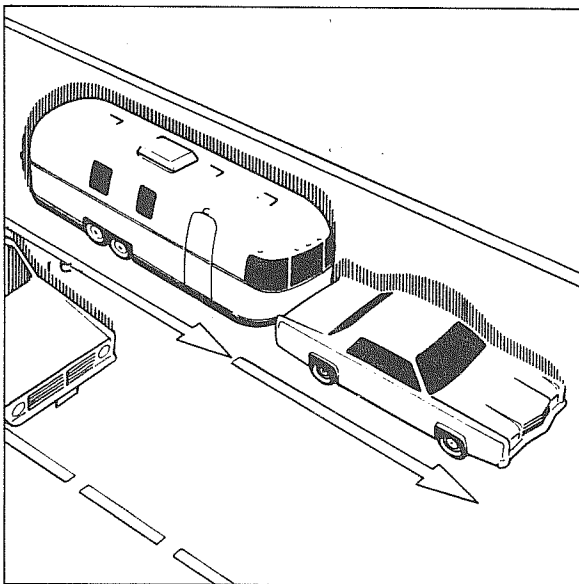

Passing

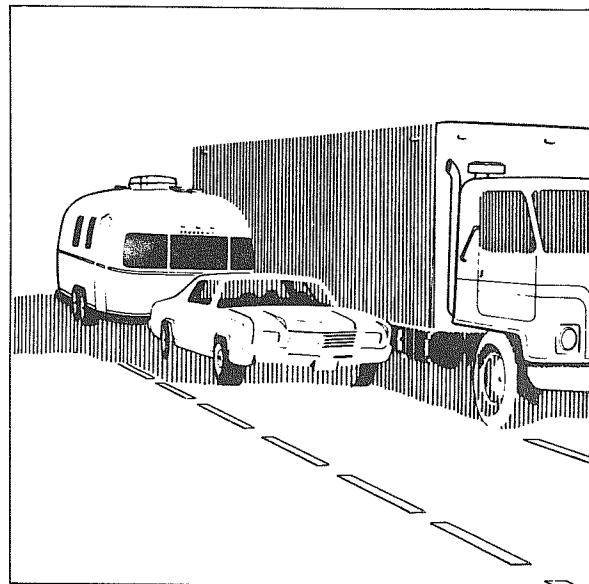

WARNING: NEVER OPEN A RADIATOR CAP WHEN THE CAR IS HOT.
CHECK THE CAR COOLANT LEVEL WHEN THE CAR IS COOL.

When going downhill in dry weather, down shift so that engine compression will slow the whole rig down. Take dips and depressions in the road slowly and do not resume normal driving speeds until you are sure that the trailer wheels are clear of the dip.

WARNING: On slippery pavement do not use engine drag to help slow down as this may cause the rear wheels of the car to skid. On icy pavement drive slowly and if you feel the car is skidding gently apply the trailer brakes only. This will bring the car and trailer back into a single line. Chassis do not help trailer wheels.

When driving in mud and sand let the momentum carry the rig through. Apply power gently and use as little as possible. Stay in the tracks of the vehicle ahead and keep the car in the highest possible gear. If you get stuck it is best to tow out both car and trailer together without unhitching.

If you have to tow long distance over bad roads, the stones and gravel thrown back by your tires will dent and scratch the finish of your trailer. To prevent this use masking tape to secure heavy cardboard to the lower front end of the trailer. Remove tape from trailer as soon as possible to avoid damage to the finish.

Despite the best hitch you will notice that whenever a large bus or truck overtakes your rig the displaced air first pushes the trailer rear slightly to the right and then affect the front. It may be necessary to steer very slightly, momentarily, toward the bus or truck to help compensate for the sway induced by the passing vehicle. Do not apply the vehicle brakes as this can tend to exaggerate the situation. You may find, however, that briefly applying the trailer brakes with your manual control will help eliminate sway.

CAUTION: When stopping on a hill or slope, leaving your car in gear is not enough for standstill safety. CHOCK THE TRAILER WHEELS to be double sure. Do not use trailer brakes as parking brakes.

In BACKING UP the important thing to remember is to DO EVERYTHING SLOWLY and to correct immediately if you see the trailer turning the wrong way. Concentrate on the rear of the trailer. With your car and trailer in a straight line, back up slowly and turn the bottom of the steering wheel in the direction you want the trailer to go. Watch out the window or in the mirror until the rear of the trailer is pointing in the desired direction. Your car will be following the trailer in an arc. Straighten the car and trailer by turning the steering wheel more sharply, then when they are in line, straighten the steering wheel.

ALWAYS TRY TO BACK TO YOUR LEFT BECAUSE THE VISIBILITY IS MUCH BETTER. (See illustration). When you don't make it on the first try it is usually much easier to pull forward to your original position and start over.

If your spouse or traveling companion normally directs you when backing they should position themselves forward of the tow vehicle so they can easily be seen by the driver. Their directions should always indicate to the driver the direction the rear of the trailer should go. A little practice in a parking lot with the person giving directions can save a lot of frustration when backing into a campsite.

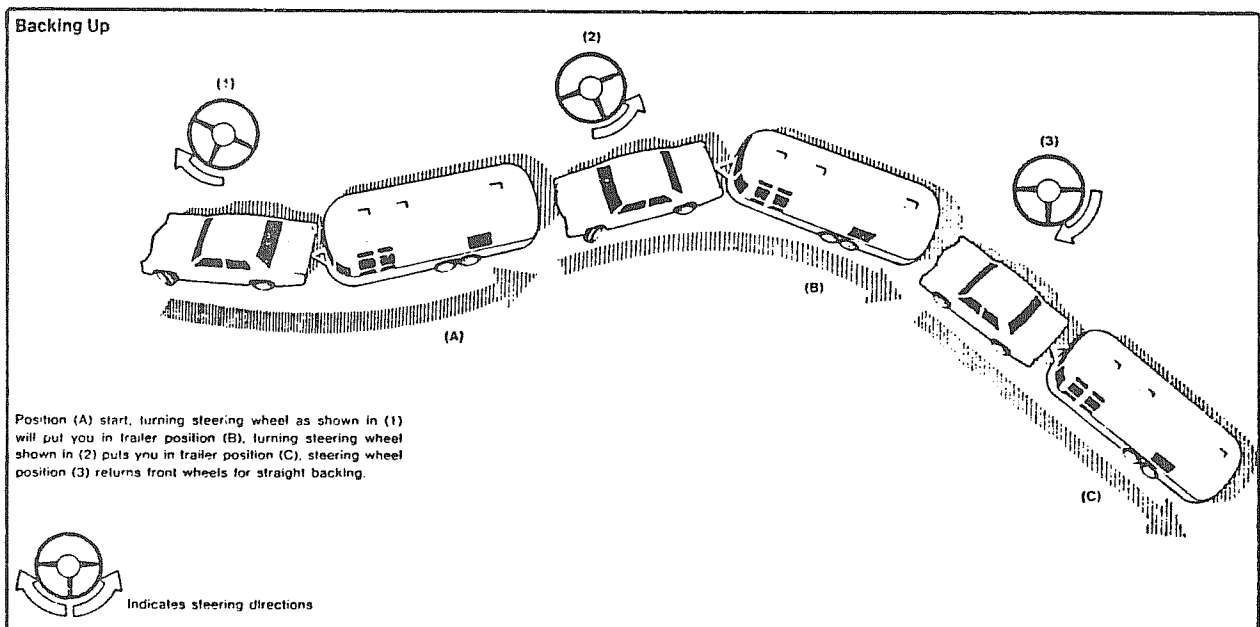

SUGGESTED PRE-TRAVEL CHECK LIST

INTERIOR

1. Turn off water pump switch.
2. Check battery water level.
3. Close windows and vents.
4. Turn off gas to range and oven.
5. Lock all interior cabinet doors.
6. Latch refrigerator door. (Seal containers first.)
7. Hold down or stack securely all loose, hard and sharp objects.
8. Fasten sliding and foldette doors.
9. Drain toilet bowl.
10. Turn off interior lights.
11. Secure and lock the main door.
12. Pull up or retract step.
13. Lower blinds and turn slats vertically.

EXTERIOR

1. Disconnect and stow:
 - a. Electrical hookup cord.
 - b. Sewer hookup hose (flush out).
 - c. Water hookup hose.
2. Turn off gas line shut-off valve to appliances.
3. Remove or stow leveling jacks and wheel chocks.
4. Check hitch: It must be properly attached.
5. Check safety chains and breakaway switch cable.
6. Fully retract jack. Remove and stow jack stand or wood block.
7. Check clearance and stop lights.
8. Check lug nuts.
9. Check tires for correct pressure.
10. Check that TV antenna is pointed forward and dipoles closed.
11. Adjust car mirrors.
12. Pull forward some 50 ft., test brakes, and check site for forgotten objects and cleanliness.

HOME

1. Leave house key with your neighbor.
2. Store valuables and important papers in a safe place.
3. Discontinue newspaper, milk and other deliveries.
4. Ask the Post Office to hold your mail for you.
5. Arrange with the telephone company for discontinued or "Vacation Service".
6. Arrange care for your pets.
7. Have your lawn, garden and houseplants cared for.
8. Lock all windows and doors securely, Keep shades open for a lived-in look.

HOME CONTINUED

9. Cover all food to keep out mice and insects.
10. Eliminate all fire hazards. Place matches in a tin box or glass jar.
11. Store oil, gasoline and other inflammables properly.
12. Destroy all newspapers, magazines and oily rags.
13. Notify police.

TRAILER EQUIPMENT AND ACCESSORIES

1. Water hose, 5/8", high pressure, tasteless, odorless, non-toxic.
2. "Y" connection - water hose.
3. Sewer hose with clamp.
4. Drain cap with hose drain.
5. Holding tank cleaner and deodorizer.
6. Power cord adapter - 30 amp capacity.
7. 50 ft. electric cord, 12-3 wire.
8. 25 ft. electric cord, 10-3 wire - 30 amp capacity.
9. Wood blocks for leveling.
10. Wheel chocks.
11. Hydraulic jacks.
12. Cross type lug wrench.
13. Quality tire gauge.
14. Emergency road warning triangle.

PERSONAL

1. Automobile insurance to cover you and your family fully.
2. Avoid cash. Use travelers check and credit cards.
3. Confirm reservations.
4. Have sunglasses for everyone.
5. Pack cameras and films.
6. Make a check list of clothing for everyone, and toilet articles.

MOTORING ESSENTIALS

1. Display car and trailer registration properly.
2. Carry driver's license. In Canada you will need a non-resident liability insurance card.
3. In Mexico you must have special auto insurance.
4. Carry an extra set of ignition and trunk keys in a separate pocket, or in your wallet.
5. Keep an operating flashlight with fresh batteries in the glove compartment.
6. Pack the trunk so that you can reach the tools and spare tire without completely unpacking.

MOTORING ESSENTIALS CONTINUED

7. Keep sharp or hard articles securely packed wherever they may be.
8. Do not pack things in the passenger seating area. You need the maximum space for comfort.
9. Wear easy-wash, drip-dry traveling clothes.
10. Do not make your vacation trips a mileage marathon. Stop and relax frequently.
11. Carry a first aid kit.
12. Carry your pet's dish, food, leash and health and registration papers.

SAFETY

As always, safety should be one of your top priorities. Make sure you, and everyone traveling with you, can operate the main door and exit window rapidly without light.

WARNING: The escape window is opened by lifting up both latches and pushing out on the glass. It is hinged at the top and will swing clear. The window operation should be checked each trip and the latches lubricated with WD-40 or equivalent every 6 months.

WARNING: At each camp sight make sure you have not parked in such a manner as to block the operation of the escape window by being too close to trees, fences or other impediments. Scenic views are one reason for traveling, but don't park so the beautiful lake or steep cliff is just outside your escape window.

WARNING: Read the directions carefully on the fire extinguisher. If there is any doubt on the operation, you and your family should practice, then replace or recharge the extinguisher. You will find your local fire department will be happy to assist you and answer any questions.

WARNING: DON'T SMOKE IN BED!
KEEP MATCHES OUT OF REACH OF SMALL CHILDREN!
DON'T CLEAN WITH FLAMMABLE MATERIAL!
KEEP FLAMMABLE MATERIAL AWAY FROM OPEN FLAME!

We have all heard these warnings many times; but, they are still among the leading causes of fires.

Other safety information on the LPG System of your trailer is located in the Plumbing Section of this manual.

OVERNIGHT STOP

Travel Trailer owners have parked virtually everywhere imaginable from filling stations to farm lands. In time you will develop a knack for spotting wonderful little roadside locations by turning off the main highway and exploring.

There are many modern trailer parks, including State, County and Federal parks with good facilities where you may obtain hookups of electrical, water and sewer connections. Directories are published which describe in detail these parks and tell what is available in the way of service and hookups.

ON OVERNIGHT OR WEEKEND TRIPS chances are you will not use up the capacity of the sewage holding tank, deplete the water supply or run down the battery which supplies the 12 volt current.

ON A LONGER TRIP, when you have stayed where sewer connections and utility hookups were not available, it will be necessary for you to stop from time to time to dispose of the waste in the holding tank and replenish the water supply. Many gas stations (chain and individually owned) have installed SANITARY DUMPING STATIONS for just this purpose. Booklets are available which list these dumping stations.

When stopping for the night your Land Yacht is built to be safely parked in any spot that is relatively level and where the ground is firm. YOUR FACILITIES ARE WITH YOU. YOU ARE SELF-CONTAINED. Unless the car is needed for transportation it is not necessary to unhitch. Try to pick as level a parking spot as possible. STABILIZING JACKS OR BLOCKS probably won't be required for an overnight stay; however, if you put the hitch jack down to take the weight off the car's springs, it will provide some stability. If you must park on a slope, PARK FACING DOWNHILL. It is easier to level the trailer this way.

All you need to do to enjoy the self-contained luxury of your Land Yacht is to:

1. Light the water heater and refrigerator pilots if required.
2. Turn on the range gas supply and light the pilot if so equipped.

Before moving on check your campsite, both for cleanliness and also to be sure you haven't left anything behind. Turn off the gas supply and make sure everything is properly stowed. Use your PRE-TRAVEL CHECK LIST and you are ready for more travel adventure.

EXTENDED STAY

Making a long trip in your Land Yacht is not very different from making a weekend excursion. Since everything you need is right at hand you are at home wherever you go. When packing for an extended trip take everything you need, but only what you need.

When you plan to stay in the same place for several days, weeks or months, you will want your trailer to be as level and steady as possible. Check the attitude with a small spirit level set on the inside work counter or the trailer hitch "A-Frame". If a correction is necessary then YOU MUST LEVEL FROM SIDE TO SIDE FIRST. This can be done easily by backing the trailer up one or more 2" x 6" boards. We do not recommend placing tires in a hole for leveling.

LEVEL FROM FRONT TO REAR by disconnecting the hitch from the car, putting the jack pad under the hitch jack and adjusting the jack up or down until you are level. Block or chock the wheels to keep the trailer from rolling. Use STABILIZING JACKS at all four corners as shown in the diagram to eliminate the natural spring action of the axles. Optional STABILIZING JACKS should only be used to stabilize the trailer.

WARNING: Whenever the trailer must be lifted with a jack, as when changing a tire or leveling on very rough terrain, ALWAYS PLACE THE LIFTING JACK UNDER THE MAIN FRAME RAIL. A label is provided with an arrow pointing to the exact location a jack should be placed. Also indicating the proper location is a 3" x 3" square patch, riveted to the main frame rail.

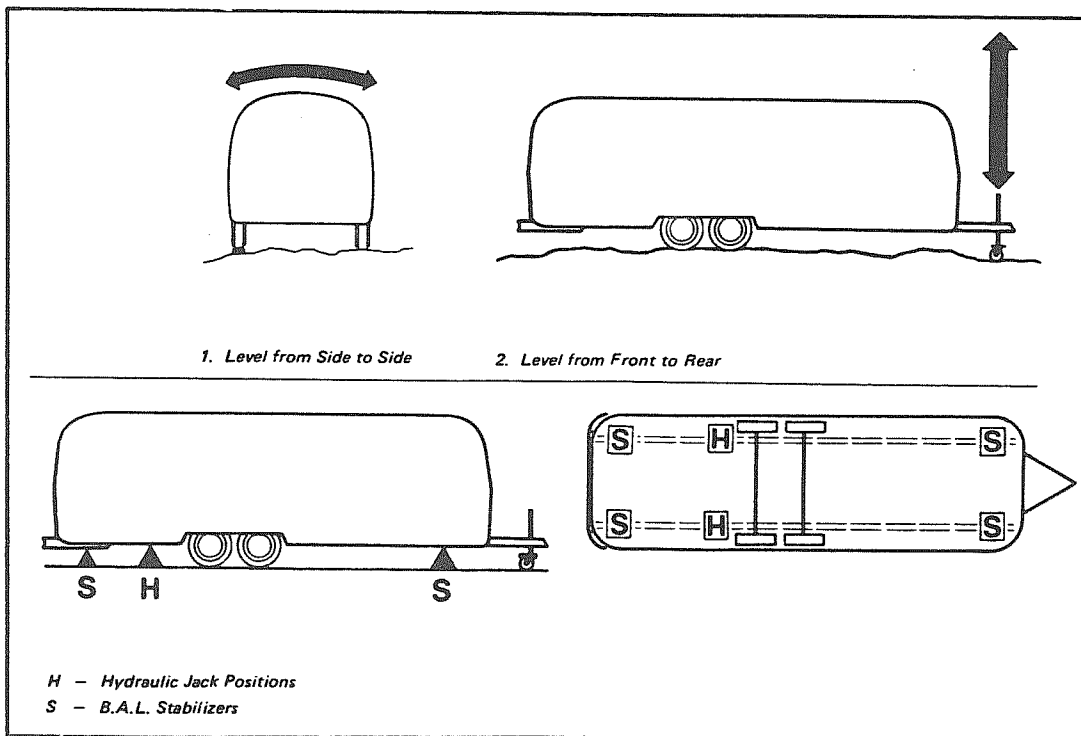

HOOK UP TO WATER by attaching a 1/2" minimum high pressure water hose to the city water service located by the water heater.

The POWER CORD, used to provide 110 volt current to the trailer, is located in the underbelly compartment directly behind the wheels. The cord is wound up on a slide out tray. Slide the tray straight out until the stops are reached, then lower it vertically. Once the desired amount of wire is free, the tray can be slid back into position and the wire placed in the notch of the door so it can be closed.

Hook your WASTE DRAIN HOSE into the SEWER DISPOSAL FACILITY and attach to the drain outlet in your trailer. Leave valve closed and dump the tanks only when they contain enough liquids to flush the solids.

Turn on gas supply, light the range and oven pilots, turn on the water heater, refrigerator and furnace.

When you stay for an extended period where electric or water hookups are not available you must make regular checks on the condition of your 12 volt battery by hooking up the car/trailer electrical connector and running the car engine at a fast idle. 45 minutes per day should provide about 3-4 hours of power. Carry drinking water in a clean bucket to refill your tank. When your waste tank nears capacity move to a dumping location.

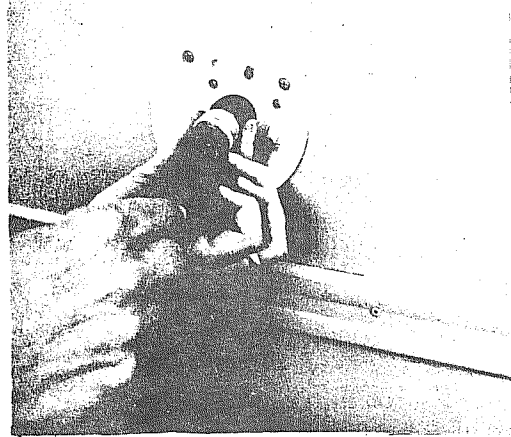

City Water Supply Connection

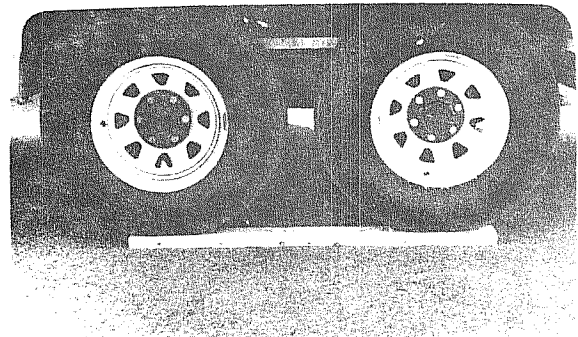

Trailer Leveling

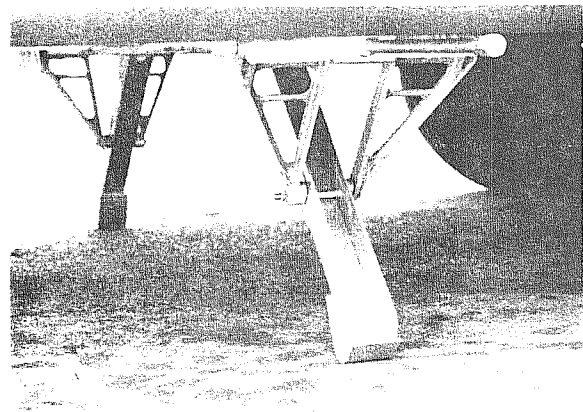

B A L Stabilizing Jack

WINTER TRAVELING

Traveling in sub-freezing temperatures will require certain precautions to protect the plumbing system and your personal belongings from being damaged by freezing.

Whenever possible the heat should be kept on at a constant temperature. It is easier for the furnace to keep a constant room temperature than for the trailer temperature to be allowed to drop to 50 degrees Fahrenheit then attempt to raise it to room temperature.

WARNING: Always shut off the LP gas when gasoline is added to the tow vehicle.

Some states do not allow LPG to be turned on while moving. While traveling in these states you must use your common sense. How cold is it? How long will it be before you can turn the heat back on? Is the temperature dropping or raising? Remember, when towing the wind chill factor at speeds of 50 MPH will cause the interior of the trailer to cool much faster than a trailer that is parked.

When parked in sub-freezing temperatures make sure you keep a full supply of LP gas and plug into a 110 volt power source whenever possible. A fully charged battery will not last more than 8 to 10 hours if the furnace is running almost constantly and 110 volt power is not available.

Leave cabinet doors, wardrobes and bed doors partially open to allow warm air to circulate around plumbing lines and fixtures. Insulate and/or wrap your exterior water lines with heat tape.

It is also important to guard against excessive humidity. Cold air will not hold the moisture and "sweating" will occur around window frames, on window glass and may occur where structural beams connect the inner and outer walls of the trailer. The best method to combat sweating is to hold water vapor producing functions to a minimum. Boiling water, baths, showers, washing dishes are necessities, but can usually be reduced. Opening windows just slightly on the opposite sides of the trailer will also help alleviate the problem. In severe conditions you may want to use a small dehumidifier to aid in reducing condensation.

Note: The Land Yacht trailer is built as a recreational vehicle and is not intended as a permanent dwelling or for more than temporary use in sub-freezing temperatures.

EXTERIOR

CLEANING

The exterior of your Land Yacht trailer is a baked enamel finish that requires the same care as you would give your automobile. Wash about every month with mild detergent. CAUTION: A dry trailer should never be wiped with a dry cloth as this could cause scratching of the finish. Tar can be removed by using any of the tar removal products on the market. Waxing twice a year (or more frequently if the trailer is exposed to industrial fall out) will make subsequent washing easier and preserve the original finish.

The A-frame, bumper and step should be touched up on a yearly basis. The paint is available in aerosol cans from your dealer.

To clean bugs from the front window stone shield use warm water and a mild detergent. Use a soft wash mitt and keep soaking the bugs until they soften enough to wash off. This job is easier if it is done immediately following a rain or after a heavy dew that will already have the bugs softened to some degree.

Sealant around windows, vents, doors and other exterior seams should be checked while washing the unit. If it becomes dry or cracks it should be replaced. Use Kool Seal sealer applied with a standard caulking gun. The tip of the caulking gun should be cut so the opening is as small as possible. Practice by running a bead of sealer on scrap material so you get the feel of how fast the sealer should be applied. If you are not used to working with sealers you should have your dealer do the work so it will be applied as neatly as possible.

DOORS AND STORAGE

CAUTION: It is important that the main door be completely closed and locked during towing. If it is not locked, the constant vibration of travel may cause it to open with possible damage.

FOR YOUR SECURITY THE LOCK HAS BEEN DESIGNED AS A DEAD BOLT. For this reason never try to shut the door when the striker is in the locked position. The door is properly closed when the handle is firm. If the door is difficult to open push in to release the latch.

An additional keyed dead bolt is standard on the trailers. To lock, insert key, turn clockwise as far as possible, then return key to vertical position allowing it to be withdrawn. To unlock, repeat procedure, only turning in the opposite direction.

DOORS AND STORAGE CONTINUED

The SCREEN DOOR secures to the main door by means of a slide bolt type latch. It can be operated independently by releasing the slide bolt and swinging the screen door away from the main door. A roller catch is provided to secure the screen door to the frame when closed.

Two STORAGE COMPARTMENTS are located on the exterior of the Argosy behind the wheels on the roadside.

The FORWARD of these two COMPARTMENTS is for storing the electric power cord. After the exterior latch is released, and the door is lowered, you will see the power cord coiled on a flat tray. Pull the tray out until it reaches the stop, then let it swing down for easy access to the cord. Only unwind the amount of cord you need to easily reach the receptacle. Leave the remaining length coiled on the tray and slide it back up into the stowed position. Swing the interior door up and work the power cord through the rubber grommet on the end of the door.

The SECOND STORAGE DOOR is for storing the sewer hose. You will note it is lined with plastic and has a snap out drain plug to make it easy to wash and rinse.

Both of these side exterior doors are designed for the upper edge to fit under a lip at the top. Position one end under the lip, then hold the other end in position as the latch is being closed. The springiness of new gasket may make this a little unhandy the first few times, but the doors will be easier to operate as the gasket takes a set.

Directly under the rear window is a LARGE LOCKABLE STORAGE AREA. This is an excellent area for storing water hoses, extension cords, leveling blocks, wheel chocks, and other bulky items used when setting up in a camping area.

WARNING: Keep the weight in the rear compartment at a reasonable level. Never add heavy items to the rear of the trailer such as large tool boxes, motorcycles and generators. This is not only considered abuse, and voids the warranty, but adding weight to the rear of the trailer is extremely detrimental to its towing ability and could cause you to lose control unexpectedly.

The GAS BOTTLE COVER on the front of the trailer is easily removed by pulling the two pins on the upper corners, then sliding it forward to release the front end.

CAUTION: When replacing make sure the front is caught securely under the bracket so it can't be blown off when towing.

FRONT WINDOW COVER

The front window cover not only protects the front windows from stone damage, but also acts as a sun shade. To raise, release the lower latches and swing up to the desired height and tighten the set screws in the support arm.

WARNING: If the cover is not raised high enough to provide head room, streamers should be attached to prevent people from accidentally bumping their heads.

The cover should be lowered if high winds are apparent or forecasted.

STEP

To deploy the step, lift the front edge and pull out as far as it will go. In its stowed position the bottom step is lying flat on the top step. Raise up on the edge toward the trailer and swing it over the top until it drops down into position.

CAUTION: Never travel with step lowered or extended.

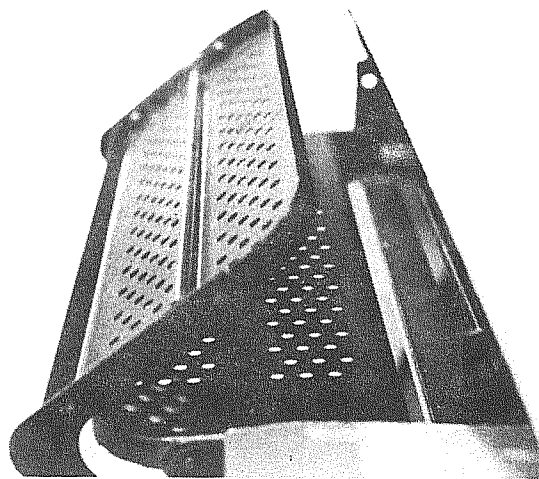

CHASSIS

The standard RECOMMENDED HITCH BALL HEIGHT for your Land Yacht is 19½". If you plan long trips with the trailer heavily loaded you should check your trailer, after loading, to determine the optimum height. To check, park the trailer on a level surface and crank the front jack up or down until the measurement from the frame to the ground is the same front and rear. Measure from the ground to the upper surface of the hitch ball coupler.

The LATCH ASSEMBLY on your coupling is a relatively simple mechanism, easily removed for cleaning. To remove use a proper size punch to drive the roll pin (see illustration) out of the latch handle. The tongue and spring will then fall free from the housing. When reassembling, compressing the roll pin with vice grip type pliers will make it easier to start through the hole.

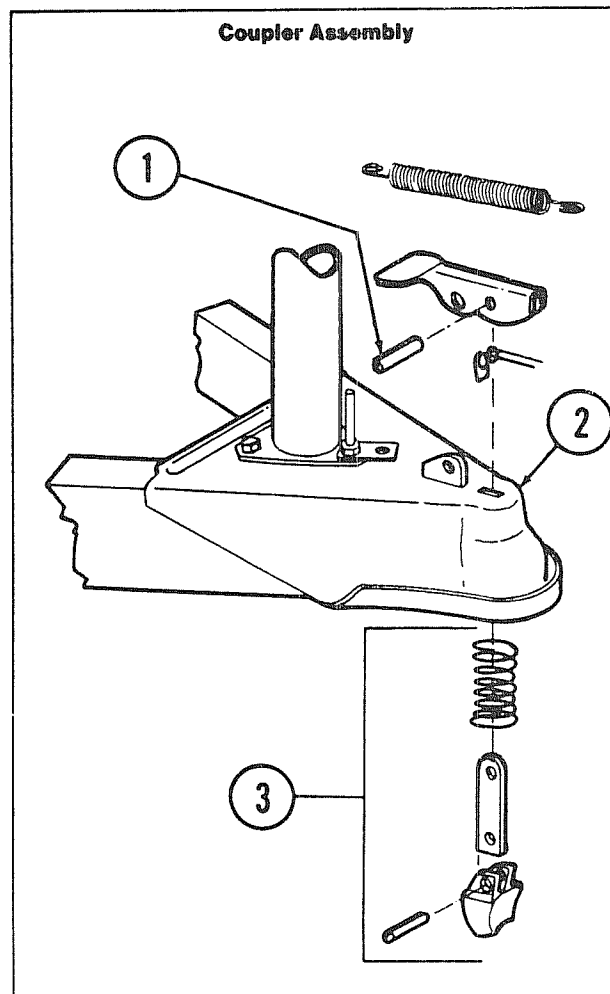

OPTIONAL POWER JACK

The optional power jack is operated by a switch located on the bottom of the housing. There is a protective cover screwed over the switch to discourage children from operating the jack and running the battery down. When the jack is fully extended or retracted internal limit switches automatically shut off the motor.

Should an electrical failure occur remove the power head by loosening the two allen set screws. The jack post may now be operated manually by inserting the emergency handle into the coupling on top of the post.

REPLACING POWER HEAD

It is essential that the following procedure is used before the power head is replaced on the post.

1. With 12 volts connected, ground the power head to trailer "A" frame. Operate main switch in the "post retracting direction" until the motor stops automatically.
2. Using emergency handle, crank post clockwise by hand until fully retracted, then turn crank one turn counterclockwise.
3. Replace head on post and make sure that drive pin is engaged with post coupler. Tighten allen set screws.

MAINTENANCE

1. Every two years remove screws and cover and check grease condition. Use a HMP grease similar to Lubriplate 630AA and spread on gear teeth. Grease is not required on the nylon timing gears. No internal lubrication of the post is required, but an occasional external application of a silicone or WD-40 spray lubricant on the inner tube of the post when extended is permissible.
2. Before replacing the cover ensure that the plate and limit switch unit are located correctly.
3. Apply a little sealing compound around the mating surface of the gear cover and replace screws tightening them diagonally. Check synchronization if head has been removed from the post.
4. A little penetrating oil on the allen set screws occasionally will help prevent corrosion and difficult removal.

NOTE: Leave tow vehicle transmission in neutral when lifting both units. Dolly wheels are not recommended. Always retract stabilizing jacks before using your Super Jack under load.

SUPER POWER JACK ASSEMBLY

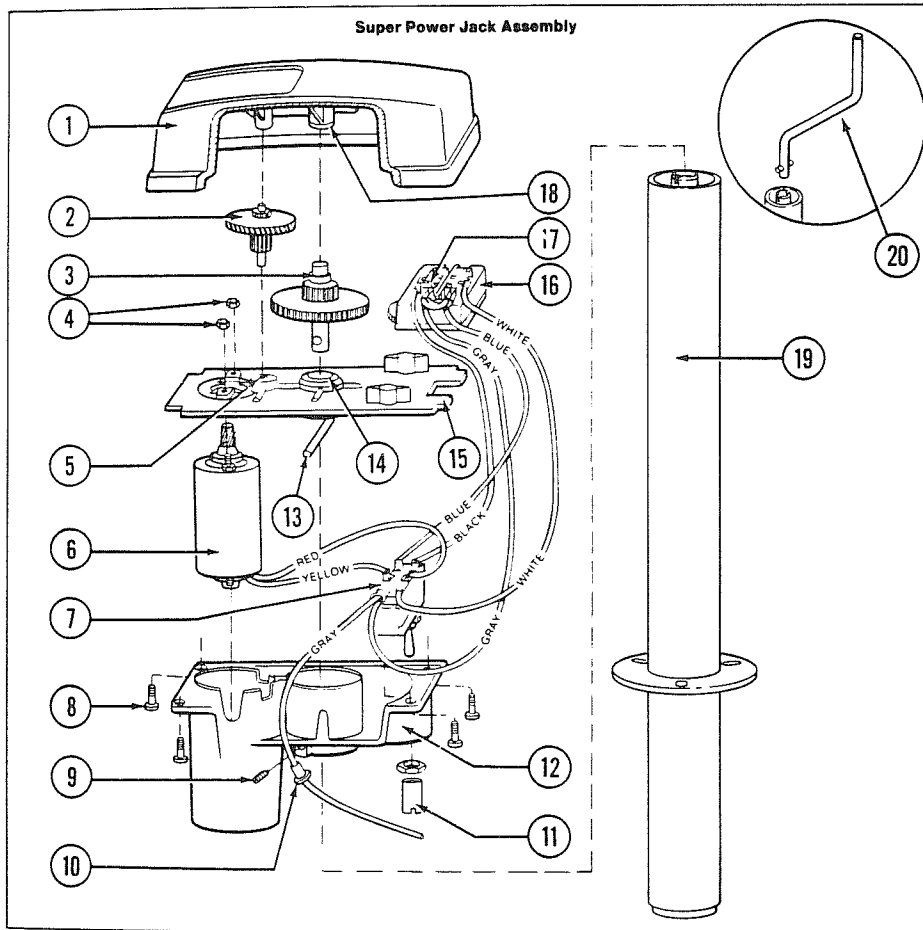

- | | |
|---|---|
| 1. Cover | 13. Groove type pin |
| 2. 2nd/3rd gear assembly | 14. Bushing 7/16" ID x 5/8 OD X 5/8" |
| 3. Drive gear assembly | 15. Plate centering |
| 4. Lock nut, No 10-24 | 16. Limit switch assembly |
| 5. Bushing, No 3, 3/16" ID X 5/16 OD x 1/4" | 17. Micro switch |
| 6. Motor assembly | 18. Bushing No 2, 5/16" ID X 7/16" OD X 3/8" |
| 7. Toggle Switch | 19. Mechanical ball jack post (less power head) |
| 8. Screw No. 8 x 1/2" type 23, PH Phillips | 20. Emergency handle |
| 9. Set Screw 1/4" -20 x 5/16" | 21. Hex wrench (not shown) |
| 10. Strain relief bushing | 22. Power jack stand (not shown) |
| 11. Metal switch cover | |
| 12. Motor and switch housing | |

TIRES

Your trailer is equipped at the factory with name brand trailer tires. Land Yacht dealers cannot make adjustments to tires. This must be done by a dealer who handles that particular brand. If you ever have tire problems check the local telephone directory for the nearest dealer.

To get the maximum performance from your tires check the air pressure often, but only when the tires are cool. Never bleed out air immediately after driving. Recommended tire pressure is 50 psi for bias ply tires.

WARNING: It is also important to periodically check on the tightness of lug nuts. They should be tightened to a torque of 90-95 ft. lbs.

In a warm climate park out of the sun whenever possible. In desert regions use tire covers to prevent ultra-violet deterioration to tires.

Removing the gas bottle cover exposes the mechanism that holds the SPARE TIRE up against the bottom of the A-frame. Turning the nut, with the crank handle provided (same as the handle used with optional BAL jacks) counterclockwise will unwind the cable and lower the tire to the ground. Unwinding the cable completely will allow the spare tire to be pulled out to the side where it can easily be unhooked from the bracket.

To CHANGE A TIRE with a jack see the label affixed to the underbelly just to the rear of the wheels. This label, Jack ↓ points to the plate riveted to the main frame where the jack head must be placed. A flat tire may also be changed without the aid of a jack. Drive the unit up a ramp 8" wide, 6" high and about 3 feet long at the base. Position the good tire on the ramp. This will raise the flat tire clear of the ground.

WARNING: Never attempt to change any tire without securely chocking remaining wheels. Never position yourself in a manner where a raised trailer can come down on you if it should be come dislodged from a jack or ramp.

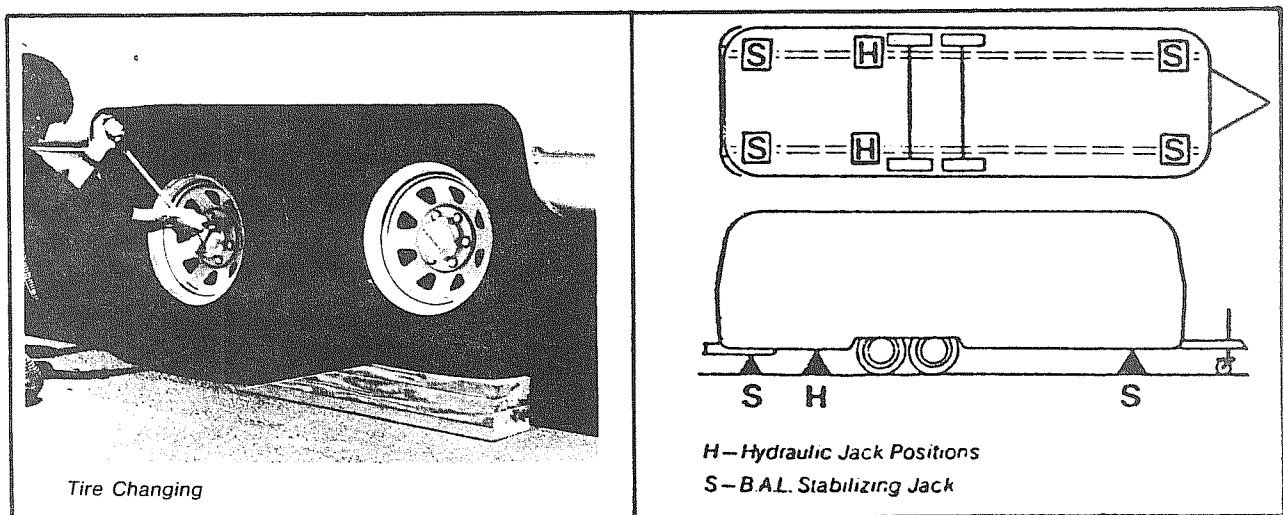

In an emergency remove the flat tire. The independent suspension of the Duro-Torque axle allows four wheel units to be safely towed on three wheels for a short distance (100 miles maximum) and only at a low speed (30 MPH).

Be especially cautious in crossing holes or dips in the road. Under these circumstances it is good practice to set your rear view mirrors so that you can observe your tires at all times.

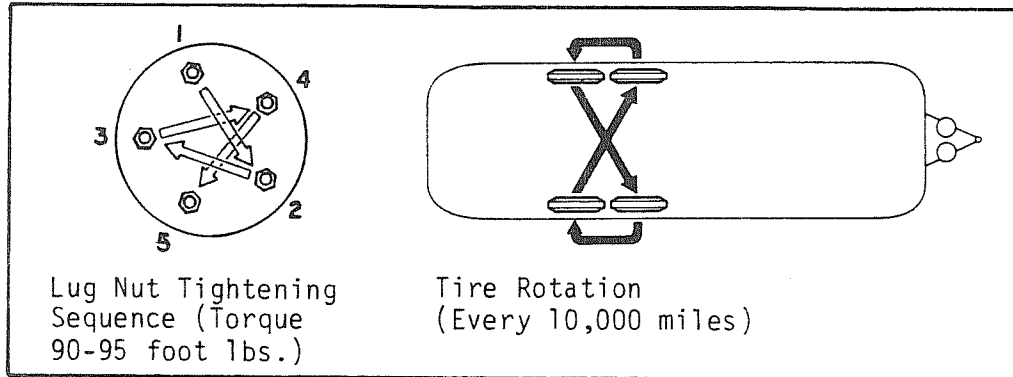

TIPS ON TIRE CARE

Any tire, no matter how well constructed, may fail in use as a result of punctures, impact damage, improper inflation or other conditions resulting from use. Tire failures may create a risk of property damage or personal injury. To reduce the risk of tire failure we strongly recommend the following:

1. CHECK the pressure in your tires, including your spare, at least monthly when the tires are cool (after the vehicle has been stopped three hours and then driven less than one mile). Do not reduce pressure when tires are hot. Use a tire gauge to check pressure and maintain it at the recommended level.
2. NEVER overload your tires. The maximum load carrying capability of your tires is molded on the sidewall of the tire.
3. CHECK your tires frequently for scrapes, bulges, separations, cuts or snags resulting from use. See your tire dealer immediately if any such condition is discovered.
4. NEVER operate your vehicle in excess of lawful speeds or the maximum speeds justified by driving conditions, or in excess of speeds recommended for the tire you are using.
5. MAKE every effort to avoid running over objects that may damage the tire through impact or cutting, such as chuckholes, glass, metal, etc.
6. NEVER drive on smooth tires. Tires should be removed when $2/32$ inch of tread depth remains. In most states it is illegal to drive with less than $2/32$ inch remaining tread depth.

AXLE AND RUNNING GEAR ASSEMBLY

Each Land Yacht DURA TORQUE axle is aligned during manufacturing, and double checked on a random basis. Alignment after delivery is the customer's responsibility.

Hitting chuck holes or rough railroad tracks while going straight will only cause misalignment after the tire has been struck many repetitive times. Of course, a deep enough hole can affect the alignment immediately.

The worse culprit is curbs because they are normally struck at an angle. Surprisingly rear axles are occasionally damaged when people are attempting to park beside a curb and are backing up their trailer.

As you look under your trailer it is normal for the axle to be bent up in the middle. This bend is how the camber is obtained.

Toe-in is built into the axle by very slight bends in the axle tube on each end.

Should tire wear ever indicate misalignment check with your dealer for the nearest location having the proper equipment.

CAUTION: Never allow heat to be applied to the axle tube since the rubber providing the spring-torsion action will be severely damaged.

DURA TORQUE AXLE ALIGNMENT SPECIFICATIONS

Toe-in each side 1/16"	Tolerance 1/16" + or -
Camber each side 3/4° Positive	Tolerance 3/4° + or -

WHEEL BEARING MAINTENANCE

1. Jack trailer at marked jack location pad behind axle on main frame.
2. Index marks should be added to wheel and drum. Realign these marks when replacing wheel thus eliminating the need for wheel/drum rebalance.
3. Remove hub cap or spindle cover, wheel and tire.
4. Remove dust cap.

WHEEL BEARING MAINTENANCE CONTINUED

5. Remove cotter pin.
6. Remove spindle nut and washer.
7. Remove bearings, hub and rotor.
8. Lay down hub and rotor with inside grease seal down. Knock out inner bearing and grease seal using wood or plastic dowel and hammer.
9. Clean all parts thoroughly with kerosene.
10. Check all bearings and races for chips or roughness of any kind. Any damaged component must be replaced.
11. Pack bearing with a good grease (No. 2 grade - 265 ASTM penetration or equivalent).
12. Install inner bearing.
13. Install new grease seal in hub and rotor using wooden or rawhide mallet.
14. Install hub and drum on spindle.
15. Install outer bearing.
16. Install washer and spindle nut.
17. While rotating the wheel, tighten the spindle nut with a 12" wrench until there is a slight tension. Then back off one notch and install cotter pin. There should now be from .001" to .010" end play in hub. If not, back off one more notch.
18. Install the tire and wheel, making sure all wheel bolts are properly torqued to specifications.
19. Check and retighten the lug bolts if necessary, every 50 miles for the first 200 miles of travel. They should be tightened to torque of 90-95 ft. lbs.

AXLE AND RUNNING GEAR ASSEMBLY

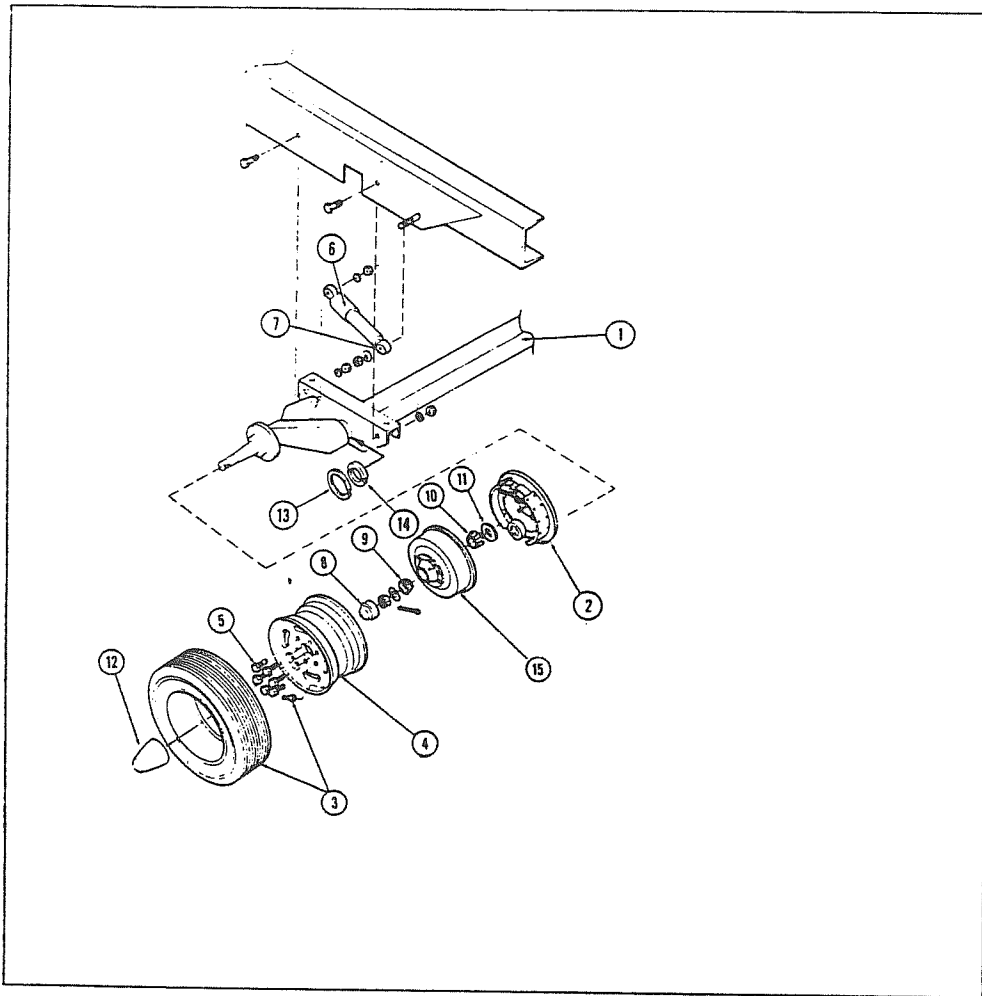

1. Dura Torque Axle
2. Brake set
3. Valve stem
4. Wheel
5. Lug nuts
6. Shock absorber
7. Shock absorber bushing
8. Dust cover
9. Outer bearing
10. Inner bearing
11. Grease seal
12. Spindle cover
13. Retainer ring
14. Nylon bushing
15. Unicast hub and drum

ELECTRIC BRAKES

A CONTROLLER installed in your car will synchronize the trailer brakes with your car brakes. It is designed to apply the trailer brakes whenever the tow vehicle brakes are applied.

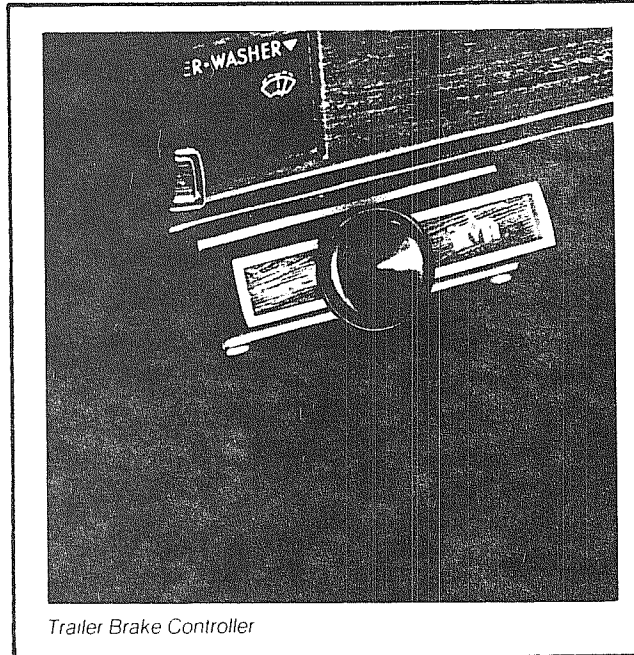

The controller handle adjustment affects the rate of application of the trailer brakes. This adjustment has no bearing on the maximum braking capacity of the trailer brakes. Because of the wide variety of towing vehicles and trailers it is necessary to balance the trailer brakes with the towing vehicle brakes to provide for a safe, comfortable stop. This adjustment should be made to provide for a slight lead of the trailer brakes over the tow vehicle brakes. Turning the handle clockwise will decrease the rate of application of the trailer brakes, while counterclockwise will increase the rate of application. When the desired setting is reached, the controller will hold the adjustment, but may be varied at any time by rotating the handle as described above. After this adjustment there should be no sensation of the trailer pushing the car during a stop, nor should there be an excessive sensation of the trailer pulling the car during a stop.

In THE EVENT OF AN ACCIDENTAL SEPARATION of the tow car and trailer, THE BREAKAWAY SWITCH will set and lock the trailer brakes for a sufficient length of time to stop the trailer. The switch is activated when the small pin in the front of the unit is pulled out by the wire attached to it and to the car. THIS PIN SHOULD BE PULLED OUT, LUBRICATED WITH LIGHT HOUSEHOLD OIL AND REPLACED EVERY 90 DAYS.

To prevent corrosion within the breakaway switch, pull the switch's pin straight forward and spray the inside of the switch through the hole with an electric contact cleaner (such as Spra-Kleen) and reinsert the pin. A drop of light household oil on the groove near

ELECTRIC BRAKES CONTINUED

the base of the pin will allow the pin to operate freely. WHEN THE TRAILER IS CONNECTED TO THE TOW CAR, THE BREAK-AWAY SWITCH LOOP SHOULD BE ATTACHED TO THE PERMANENT FRAME OF YOUR HITCH. When disconnecting trailer from tow car, remove wire loop from the frame. DO NOT REMOVE PIN FROM SWITCH BECAUSE THIS WILL APPLY THE TRAILER BRAKES.

CAUTION: DO NOT USE BREAK-AWAY SWITCH FOR PARKING BRAKE

BACKING PLATE AND SHOE ASSEMBLY

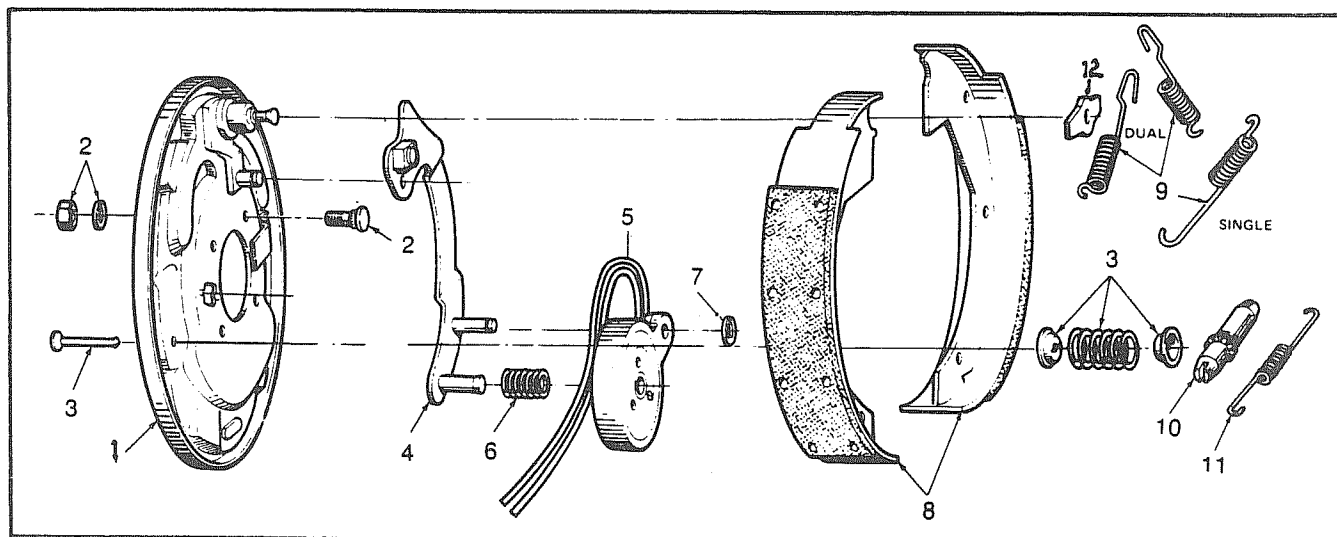

1. Backing plate
2. Mounting bolts and nuts
3. Springs, cups, pin, shoe retainer
4. Actuating lever
5. Magnet
6. Magnet spring
7. Snap ring, magnet
8. Brake shoes
9. Retractor spring, dual or single
10. Adjusting screw
11. Spring, adjustor
12. Retainer, upper, brake shoes

BRAKE ADJUSTMENT

1. This should be done at least every year or 10,000 miles whichever comes first.
2. Jack trailer at marked jack location pad behind axle on main frame.
3. Remove the small rubber plug at the base of the backing plate.
4. While turning the wheel and tire, tighten the brakes (Fig. 1) using a brake adjusting tool or a screw driver bent to a 90 degree angle until the wheel has a heavy drag. Then back off until the wheel turns freely.
5. Replace rubber plug.
6. Repeat this operation with all trailer wheels.

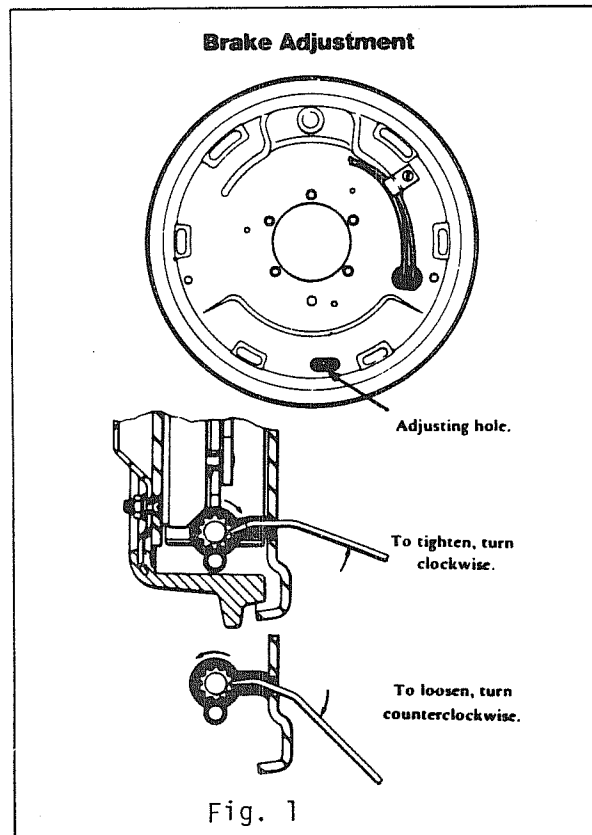

BRAKE ASSEMBLY REMOVAL AND INSTALLATION

1. Jack trailer at marked jack location and behind axle on main frame.
2. Index marks should be added to wheel and drum. Realign these marks when replacing wheel thus eliminating the need for wheel/drum rebalance.
3. Remove hub cap or spindle cover, wheel and tire.
4. Remove dust cap.
5. Remove cotter pin.
6. Remove spindle nut and washer.
7. Remove hub/drum and outer bearing.
8. Remove brake by taking off five bolts attaching brake to brake flange and spindle.
9. To install, reverse procedure. Be sure bearings are clean before installing.

CHECKING, REPAIRING AND REPLACING ELECTRICAL COMPONENTS (After brake assembly removal)

1. Test instrument.

In order to properly check the electrical circuit and components, a D.C. ammeter having a range of approximately 0-15 amps should be used.

2. Test the Circuit.

First check the continuity of the system. To do this connect the trailer to the towing vehicle, then place the ammeter in the circuit as shown in Fig. 2.

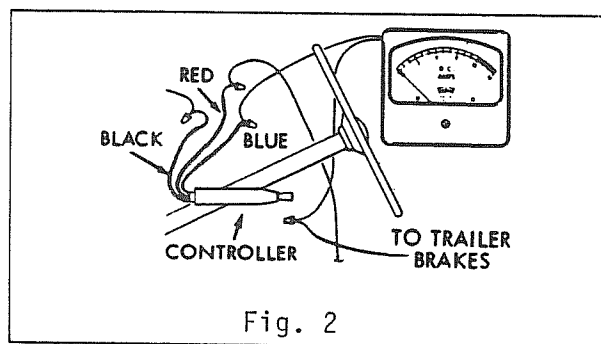

NOTE: You can avoid possible damage to the ammeter by connecting one lead, then just touch the other lead quickly. If the needle goes the wrong way you have reversed the polarity. To correct, simply reverse the leads, then complete the connection. Now operate the controller slowly. The cut-in or lowest current should read from 2 to 3 amps. Move lever completely to right. AMP reading should be 12.0 to 13.0 amps. These values are without the selective resistor in the circuit. It should be bypassed by putting both wires on a common terminal.

If the ammeter registers the correct high and low reading and shows smooth current modulation, you may assume that the controller is functioning properly. If you do not show the correct high and low, or the modulation is poor, check the following electrical circuit problems.

A. CIRCUIT CHECK

Check 7-way connector for proper engagement and cleanliness.

Check all terminal points and splices in both tow vehicle and trailer.

NOTE: Sometimes a fuse has been installed in tow vehicle portion of brake circuit. (This is not recommended.)

B. CONTROLLER CHECK

Remove controller from tow vehicle and connect the ammeter as shown in Fig. 3. The ammeter should vary smoothly from "OFF" to "ON". If it does not vary smoothly or shows no current when the controller is at full "ON", remove the controller cover and inspect the resistor coil. If the coil is burned out it must be replaced. A burned out coil can be detected by visual inspection.

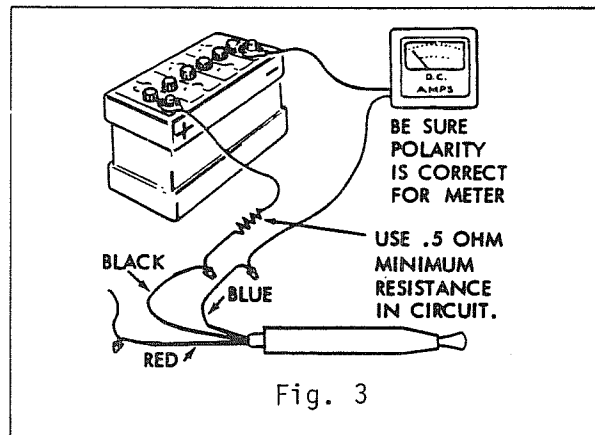

CAUTION: The resistor coil should last indefinitely under normal operating conditions. If the coil is burned out, carefully check the entire electrical system for a short circuited condition. A short circuit can damage any electric brake controller.

After replacing the coil be sure there is at least .020" clearance between the contactor strip and the coil when the controller handle is unapplied.

C. STOP LIGHT SWITCH

First check the continuity of the system. To do this connect the trailer to the towing vehicle, then place the ammeter in the circuit as shown in Fig. 4.

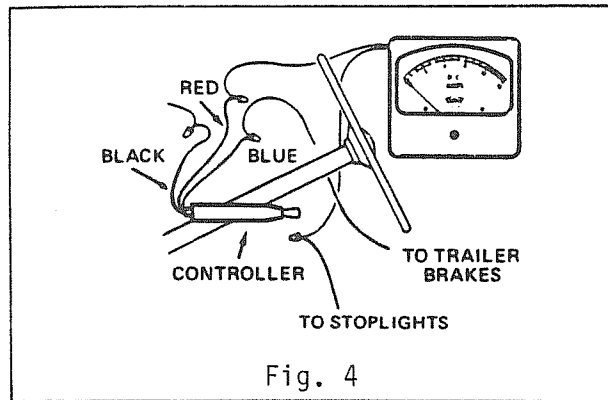

NOTE: Whenever connecting the ammeter you can avoid possible damage to the ammeter by connecting one lead then just touching the other lead quickly. If the needle goes the wrong way you have reversed the polarity. To correct, simply reverse the leads, then complete the connection.

All controllers are equipped with a separate stop light switch which allows full current to flow to the trailer stop lights throughout brake application. It should be at .020" gap when the controller handle is unapplied. This gap can be adjusted by loosening one screw through an access hole in the bottom on the controller case.

D. HYDRAULIC CYLINDER LEAKAGE

When checking the electrical circuit of the controller it is advisable to check its hydraulic cylinder at the same time to be sure it is tight and free of leakage.

If leakage does occur it is recommended that the complete hydraulic cylinder assembly be replaced. When reconnecting the controller into the hydraulic system of the tow car bleed and check connections.

C. BLEEDING THE HYDRAULIC BRAKE LINE

Removing air from the brake system is easy to do and very important. Follow the procedure given in Fig. 5 carefully. Then wipe away all excess of brake fluid to avoid damage to painted surfaces. Refill the master cylinder reservoir.

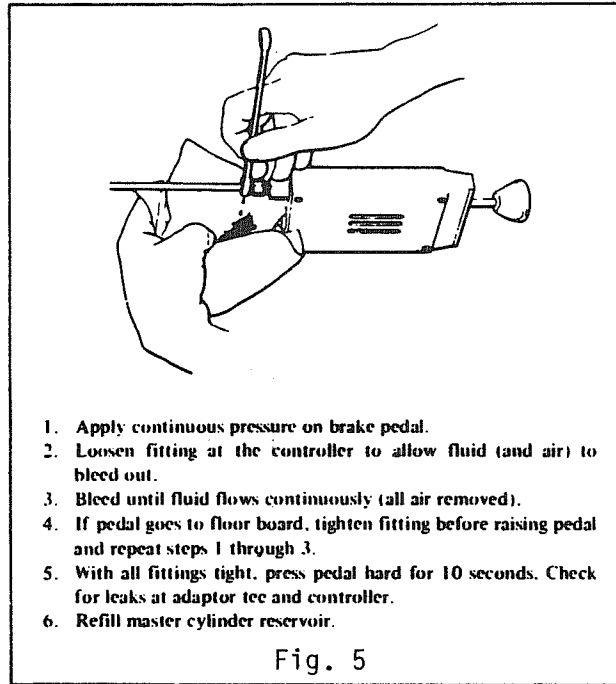

NOTE: If pedal is spongy after bleeding at controller it may be necessary to bleed the system at the wheel cylinders. All automotive hydraulic brakes have a bleeder screw on the backing plates or disc brake for this purpose.

F. SPECIAL NOTE ON FAILURE SWITCH RESET

All 1967 and later vehicles have a brake failure warning lamp on the instrument panel. This lamp should remain unlit during brake applications after the installation of the controller. It may inadvertently be switched "on" if excess pressure is applied during the controller hydraulic line bleeding, and must be reset.

G. PROCEDURE FOR RESETTING SWITCH

Ford Motor Company vehicles must be reverse bled in order to reset this switch. To do this, loosen a front connection on the safety switch and rebleed the system. If any difficulty occurs in resetting the switch refer to the vehicle manufacturer's shop manual.

Chrysler and General Motors vehicles have failure lamp switches which are self-resetting and therefore should require no adjustments after controller installation.

American Motors, Kaiser Jeep and International Harvester failure lamp switches do not require bleeding. However, they do require loosening the connector where the failure lamp wire contacts the switch. This allows the switch to center and be reset. Consult the vehicle manufacturer's shop manual if detailed procedure is required.

H. BREAK-AWAY SWITCH

The break-away switch can be checked simply by placing an ammeter in the circuit between the break-away switch and the brakes, then pulling out the break-away pin. If no current flows to the brakes, check to be sure the break-away switch contacts are clean. If the contacts are clean, check the trailer battery for adequate charge. Recharge or replace battery if necessary.

NOTE: Break-away switch is an emergency device only, and is not to be used as a parking brake. Pull pin and lubricate with light household oil and replace every 90 days.

I. MAGNET ASSEMBLY

Without removing the magnet assembly from the brake, inspect the magnet for wear and flatness.

If the magnet rubbing surface is flat it need not be replaced until the friction element shows signs of wearing through.

A magnet that is not wearing flat must be replaced, since it cannot function efficiently. To check the wearing surface for flatness, lay a scale or straight-edge on the magnet as shown in Fig. 6.

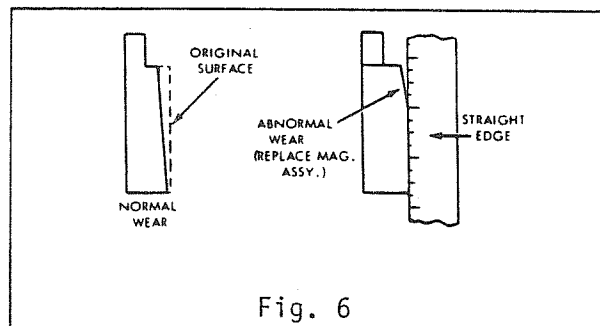
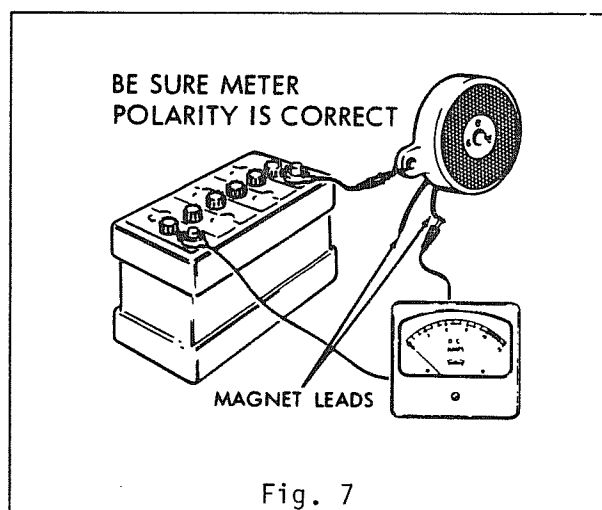

Fig. 6

Before replacing with a new magnet determine the cause of the improper wear. First check the magnet lever pivot. A worn pivot bushing can cause the magnet lever to cock, thus allowing the magnet to tip against the armature plate. If this condition exists, the lever assembly should be replaced. When reinstalling magnets be sure to install the loom (lead wires) properly, avoiding kinks and allowing ample clearance for the lever to move through its full travel. Operate the lever in both directions to be sure the loom moves properly without binding, kinking, or interfering with lever movement.

J. MAGNET BENCH CHECK

To check electrically remove the magnet for bench test. To check for a possible coil to case short connect the magnet with the ammeter as shown in Fig. 7. Since the short may be intermittent, move the leads and rap the magnet while checking. If the ammeter shows current a short is present. Replace with a new magnet assembly.



To check for possible shorts within the magnet coil, connect as shown in Fig. 8. Check current. It should be approximately 2.0 amps on 10" brake magnets. If not, replace magnet.

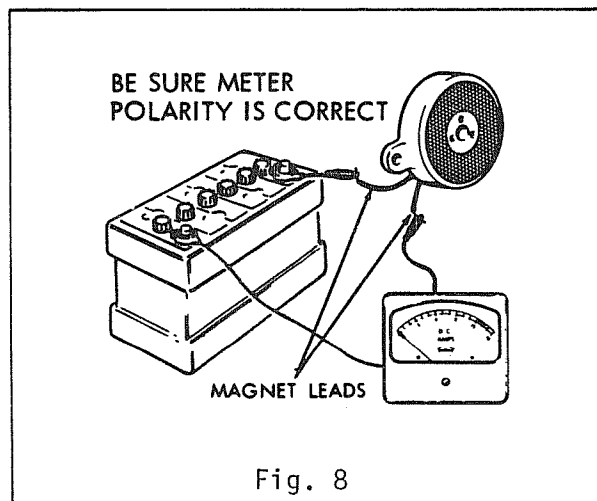

INTERIOR

The interior of your Land Yacht trailer has been designed for comfort, convenience, durability and appearance. How you use it and how you take care of it naturally depends on you. However, if you learn to operate the interior components and take care of them and the trailer properly, this knowledge will add to your pleasure as well as the long life of your trailer.

UPHOLSTERY/DRAPERIES

The upholstery and drapery material in your Land Yacht should be vacuumed or brushed with a soft brush on a regular basis to prevent accumulation of dirt. If an overall soiled condition exists, they must be professionally dry cleaned.

Before attempting to spot clean stains consult a professional dry cleaner.

Draperies are removed by unsnapping from the wall, removing a screw or pop rivet from the end of the curtain track, and sliding them out. The pop rivets are removed by drilling through the head with a 1/8" drill bit.

If you don't have the tools to replace the rivets a #8 sheet metal screw would be the correct size to use in the 1/8 inch hole.

VENETIAN TYPE BLINDS

The venetian type blinds are lowered by pulling the cord slightly to the left and releasing it. This allows the blind to extend completely. There are brackets on the wall for the blinds to hook under. By turning the plastic handle the pitch or angle of each slat can be adjusted.

To prevent damage to the draperies while traveling the blinds should be lowered, secured at the bottom and the slats turned vertically.

The blinds should be dusted frequently to prevent the build up of grime and the subsequent tedious task of washing each slat.

SMOKING WARNING:

Keep your furniture and family safe from fires caused by careless smoking. Do not smoke when drowsy. Remove immediately any flowing ash or a lighted cigarette which falls on furniture.

Smoldering smoking material can cause upholstered furniture fires.

CARPET

The carpet can be cleaned with any good commercial carpet cleaner, or with a detergent and water. BE CAREFUL NOT TO SOAK THE CARPET WITH WATER.

LINOLEUM

The linoleum in your Land Yacht is the "no wax" type, so occasional damp mopping is all that is required. There are cleaners on the market designed especially for no wax floors.

COUNTER AREAS

The counter areas around the sink are of a high-pressure laminate and can be cleaned with soap and water, or you can use a common cleaning solvent on tough spots. Be sure no abrasive cleaner is used as there is the possibility it could scratch the surface. A protective pad should always be placed under hot utensils.

STAINLESS STEEL SINKS

Stainless steel sinks cannot be harmed by boiling water. However, salt, mustard, mayonnaise and ketchup can cause pitting. Stubborn stains will yield to paste made of water and slightly abrasive household cleaner. Be sure to work in the direction of the polish lines on the steel to keep the original finish. Fingerprints are sometimes a problem. They can be minimized by applying a cleaner that leaves a film of thin wax. Simply wipe it on and remove the excess with a dry cloth. After this, fingerprints can be wiped off with a soft dry cloth, or one moistened with a little wax cleaner. The surface should always be washed before wax is applied. Regular cleaning will prevent build-up of scale and film. Ordinary soaps or detergents are best for routine cleaning of the stainless steel sinks. Rinse thoroughly with warm water and wipe dry with a cloth to avoid streaks and spots.

WALLS

The walls can be cleaned with any vinyl cleaner or with any mild household detergent and a damp cloth.

PANELING

The paneling of the wardrobes and cabinets may be waxed, if desired, or may be cleaned simply with a damp cloth.

PLASTIC BATHROOM COMPONENTS

CAUTION: The lavatory bowl, counter top, tub or shower pan in your bathroom are made of a special ABS long-wearing, light weight, high strength plastic material. WHEN CLEANING USE SOAP OR DETERGENT ONLY. NEVER USE SCOURING POWDER.

Always re wax the ABS plastic surfaces after each heavy cleaning with a good grade paste wax (without solvents or cleaners). The wax will protect the surfaces from discoloration and stains. When you first purchase your trailer Airstream recommends that you give all ABS plastic surfaces a heavy coating of paste wax. This will assure easier cleaning and lasting beauty.

One of the most competitive markets today seems to be cleaners. It seems like new or improved cleaners become available daily. Try any cleaner new to you on a small out-of-the-way area before using it generally. If you find any that are extra good pass the information along to fellow RVers.

FRONT LOUNGE

The front lounge in your Land Yacht converts into a bed. Lift up on the front and pull out until it is lying flat. It is retracted in the same manner.

The upholstered part of the lounge is fastened to the mechanism by four bolts, two on each end, through the back rest. The bolts can be removed by reaching down between the back rest and front shelf.

The complete lounge assembly is held in place by four lag bolts through the floor that can be reached by pulling the drawer assembly completely out from underneath the bed.

DINETTE

The dinette is made into a bed by raising up on the front of the table and folding the table leg up against the bottom of the leaf. As the table is raised it will unhook from the upper wall brackets. Once it is unhooked it can be pulled out and the wall hinge will let it be lowered on the supports of the dinette seats. The back rest of the seats are placed over the table to complete the conversion.

BATTERY LOCATION

The batteries are accessible through an external locking access door. The single, or optional dual batteries, are set in a plastic tray to make removal easier.

ELECTRICAL DISTRIBUTION

The electrical distribution panel is readily accessible in all models. The distribution panel incorporates both 12 volt DC fuses and the 110 volt AC breakers. They can be found in the end of the rear dinette seat by removing the upholstered panel which is located either under the lounge or below the refrigerator, depending upon the model of your trailer.

STORAGE

The kitchen cabinet should have the heaviest items on the bottom and lighter items overhead. After loading you should have the skillet and can goods on the floor or bottom shelf, and the cereals and crackers in the overhead rooflocker. Use the unbreakable type plates and saucers, and consider storing your dish towels around them. Better yet, use paper plates. Who wants to wash dishes when on a trip or vacation?

A good place to store heavy items is in the very front of the trailer at the lowest possible point. While adding some weight to the front end may even improve the towing slightly, some facts do have to be remembered. Any weight added is going almost entirely on the tongue, which should only weigh 10-15% of the trailer weight (maximum 1,000 lbs.). Also, units with a lounge across the front have a drawer which has a maximum load capacity of 100 pounds.

Clothes hung in wardrobes should be kept on hangers that snap over the clothes rods to keep them from "jumping" off on rough roads. Evening dresses should be kept in the plastic bags like dry cleaning businesses use. No matter how hard you try, if you travel a long dusty section of road the dust will work its way into the trailer and soil clothes. Try to avoid large bulky coats, Layers of lighter clothing will usually keep you warmer, are more versatile and easier to store.

WARNING: Keep flammable material away from the furnace.

Remember: Heavy items should be stored low and toward the front.
Lighter items in the rear and overhead cabinets.

SAFETY:

Many things can be construed as safety related, but the most important is your common sense. If you are careless with matches, cigarettes, flammable material or any other hazardous material, I'm sure you realize your potential for accident is greatly increased.

SMOKE DETECTOR

How to tell if the smoke detector is working right.

The alarm horn and the indicator light on your detector let you know whether your detector is working right.

- * When the indicator light, which you can see through the clear push button of the test switch, flashes once a minute, the detector is operating normally. (Model 83P has a white push button and does not flash.)
- * When the alarm is sounding, the detector has sensed smoke or combustion particles in the air. The alarm will automatically turn off when the smoke in the air is completely gone.
- * If the alarm horn beeps once a minute, the detector's battery is weak and needs to be replaced immediately.

HOW TO TAKE CARE OF YOUR DETECTOR

Your smoke detector has been designed to be as maintenance-free as possible. To keep your detector in good working order you must:

- * Test the detector regularly (weekly is recommended) by pressing on the test switch for up to 10 seconds until the alarm sounds. In RV's test the detector after storage and before each trip. Make sure your family hears the detector and knows how to react.
- * Replace the battery once a year or immediately when the low battery "beep" signal sounds once per minute. The low battery signal should last at least 30 days.

This detector uses standard nine-volt batteries. The detector will work properly with the following batteries:

Eveready #522, #1222, #216
Duracell #MN1604
Gold Peak #1604P, #1604S

Eveready and Duracell batteries are available at any retail store that sells batteries.

WARNING: Do not use any other kind of battery. The detector may not operate properly with other batteries.

- * Vacuum the dust off the detector sensing chamber at least once a year. This can be done when you open the detector to replace the battery. Remove the battery before cleaning. Use a soft brush attachment and carefully remove any dust on the detector components, especially on the openings of the sensing chamber. Replace the battery after cleaning.

Smoke Detector Continued...

- * Clean the detector's cover when it becomes dirty. First open the cover and remove the battery. Then hand wash the cover with a cloth dampened with mild soapy water, rinse it with a cloth dampened with clear water, and dry it with a lint-free cloth. Be careful not to get any water on the detector components. Replace the battery and close the cover.

Test the detector after closing the cover whenever you have opened it to replace the battery or clean it.

FIRE EXTINGUISHER

The fire extinguisher just inside your forward door should have the charge checked on a regular basis. Make sure your family, especially the cook, knows how to release the extinguisher storage bracket, and how to properly operate the extinguisher. If you find the directions on the extinguisher unclear, check with your local fire department. I'm sure they will be happy to assist you and your family.

EMERGENCY EXIT

On single door Land Yachts the roadside rear window is designed as an EMERGENCY EXIT. Raising up on the bright red handles will free the glass and allow it to swing clear.

HAVE YOU CONSIDERED HAVING YOUR FAMILY PRACTICE ESCAPING IN THE DARK?

WINDOWS

The windows in your Land Yacht are very simple to maintain and use. They are opened by turning the operating knob clockwise. One big advantage of this vent style window is the fact the windows may be left partially open during a rain, unless the wind is blowing.

WINDOW OPERATORS

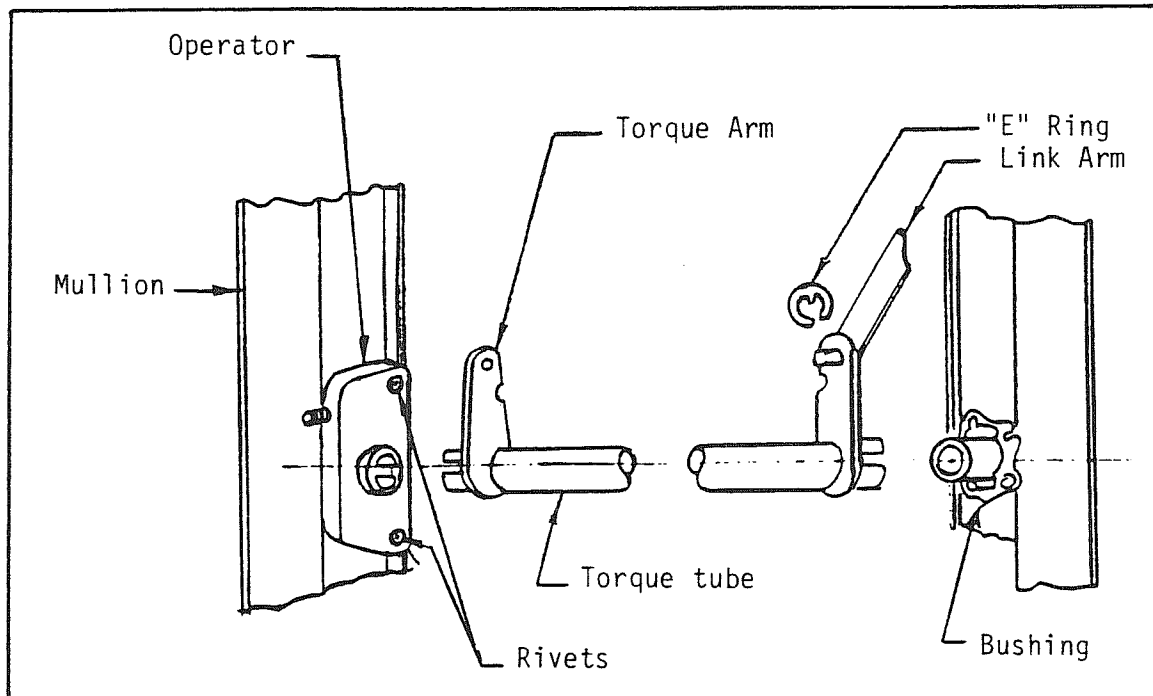

REMOVAL OF OPERATOR

Rotate the operator arms enough to relieve tension on side linkage. Carefully note the position of torque arms. Remove "E" rings at the torque arms attached to the torque tube by prying them loose. Remove handle on operator, and remove screen. Prop open the vents enough to secure working room. Carefully center punch the rivet heads on the operator and drill off with a 1/4 inch drill. Then punch the rivets out with a 1/8 inch drift punch. Pull on the torque tube while holding near the operator until it just about clears the mullion. Pull the torque tube out of the bushing and pull operator from the torque tube.

REINSTALLATION OF OPERATOR

Place torque tube into new operator and the other end of the tube into bushing. With torque arms pointing diagonally up and out, push operator end into place. Use two #6 by 3/4" machine screws with nuts to hold operator in place. Join link arms and torque arms with "E" rings.

WINDOW VENTS

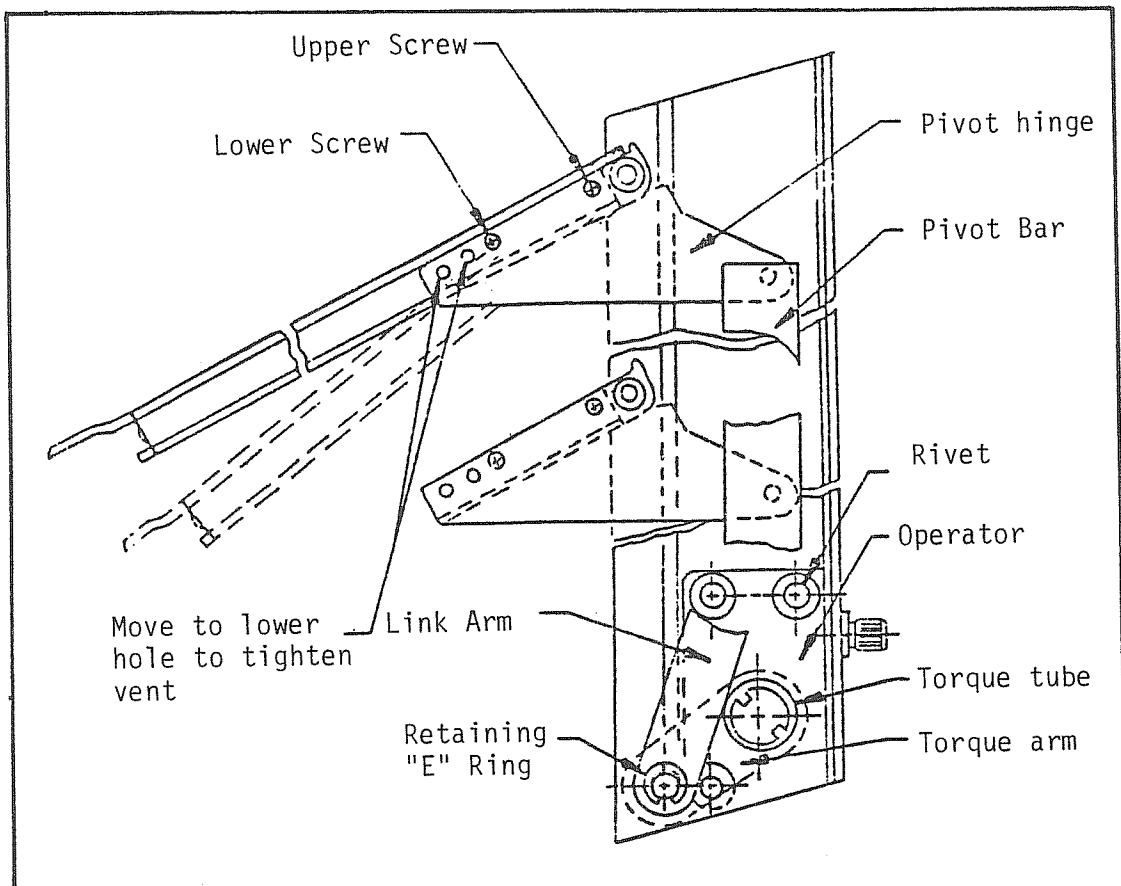

VENT ADJUSTMENT

If a vent does not close properly, adjusting holes have been provided. These holes are in the pivot hinge brackets, located on each side of each vent and plainly visible from the outside of the window. The upper screws should not be removed unless the vent has to be removed. The lower screws are for adjusting the vent closure. If a tighter closure is desired, these screws should be moved to the next hold down. If closure is too tight, move screw to next hole up.

DISASSEMBLY OF VENT FOR GLASS REPLACEMENT

With the window in a fully open position, remove all four screws holding the vent pivot brackets. Insert the blade of a screwdriver between the vent and the pivot bracket and pry the vent out. Remove the screws from the four corners of the vent frame. Place a block of wood against the inner side of the frame and tap against the wood, working it evenly across the piece until it comes off the glass.

INSTALLATION OF NEW VENT GLASS

The vent glass is $3/32$ " less than the overall height of the vent side piece and $1\ 9/19$ " less than the overall length of the vent bottom piece. If the broken glass is safety glass, it must be replaced with safety glazing material. Replace the channel rubber on the new glass. If the channel rubber has been damaged a new one can be obtained through your local dealer. Install the top and bottom pieces first, centering them on the glass and tapping them evenly until they are firmly seated. Assemble the side pieces to the glass following the same procedure. Install the screws in the four corners. Before re-installing the vent in the window, check if the vent is square, measuring it diagonally. If the tape readings are not the same, tap on the corner with the longer reading.

INSTALLATION OF NEW STATIONARY GLASS

Using a $1/8$ inch drill, drill out the pop rivets which hold the bottom of the stationary section to the backframe. Remove the Phillips head screws holding the stationary vertical section. Lift the bottom of the stationary section, pulling outward and down to remove it from the backframe.

For glass replacement use the same procedures as described in "Installation of New Vent Glass." If broken glass is safety glass, it must be replaced with safety glazing material. When re-installing the stationary section, #6 x $1/2$ " sheet metal screws could be substituted for the pop rivets.

REMOVING THE SCREEN FRAME OR STORM SASH

Push the screen frame or storm sash assembly up into the top portion of the window until the bottom of the frame is above the lip of the bottom piece of the window. Pull the bottom of the screen frame up, past the window bottom piece lip, lower the frame to where the top portion will clear the lip on the top piece and remove screen.

REMOVING SCREEN CLOTH

Remove the spline from the groove and pull the screen out. If inner frame is screened, first remove it from the interior wall.

RESCREENING

It is advisable before rescreening the frame to make some provision to keep it square, its sides parallel and prevent the tension of the screen from bowing them inward. This can be done by nailing four pieces of wood to a flat surface in a manner which will permit you to slip the frame over the outside of them. The wood will then act as spreaders, keeping the frame square and prevent bowing the screen frame while being splined into the groove. Measure the distance between the spline grooves and add about 2" to the height, and width for the screen material size. For best results use fiberglass screening material.

Lay the new screen over the frame and leave about 1" overlapping the spline grooves. Starting at one corner, insert the spline into the screen groove with a blunt screwdriver, a narrow roller or similar tool. Hold a tight tension on the screen in the direction you are working. Follow this procedure working around the frame, finishing at the corner you started. Check the screen frame to make sure it is still square and the sides are parallel. Trim the excess screen with a razor blade or sharp knife.

LUBRICATION

All moving parts and joints should be lubricated approximately once every six months with WD-40 or equivalent. The operator case is of a sealed type and does not require any lubrication.

ROOF VENTS

The roof vents in the living room and bathroom include a 12 volt fan. The fan should not be operated for long periods of time without the vent cap being opened at least a small amount.

There is no regular maintenance required. If any new parts are ever needed they are easily changed.

The vents have been installed so the side of the cap that raises is toward the rear of the trailer. This allows you to leave them partially open when you tow. RVers have argued for years about towing with the vents partially open. Some say the vents exhaust hot air when they are towing so the trailers aren't stuffy. Others say the vents cause a vacuum in the trailer and tend to suck in dust.

RANGE EXHAUST

The range exhaust has two switches. One for the fan blower motor, and the second for a light. The filter should be washed on a regular basis according to usage. Sliding the filter toward the outside wall will allow the front edge to come down out of the frame. Soak the filter in dish water and let air dry.

To change the 12 volt light bulb (#912) slide the lens down and it will come free from the frame. The bulb pulls straight out of the base.

PLUMBING SYSTEMS

LIQUID PETROLEUM GAS (LPG)

Your trailer is equipped with two tanks for LPG (Liquid Petroleum Gas). LPG burns with a clean blue flame. There are two basic types of LPG in common usage: BUTANE AND PROPANE. Butane is widely used where temperatures are normally above freezing the year round, and Propane is used when subfreezing temperatures are common, since Butane freezes at 32 degrees as compared to -40 degrees for Propane.

How long a full tank of gas will last is dependent on usage. In cold weather when you are using the furnace, large amounts of hot water, and are doing extensive cooking, you will naturally use more than you will in warm weather when you may do limited cooking. On the average, with normal cooking and other appliance use, you can probably count on two to three weeks service from each tank.

AUTOMATIC GAS REGULATOR

All models are equipped with an automatic gas regulator. Both tanks are connected to this regulator. Open both tank valves completely, then close about 1/4 turn. This will allow you to easily check to see if valves are open or closed.

When the gas is turned on it is drawn from only one tank at a time. When the tank being used is depleted the regulator automatically switches to the full tank. An indicator on the regulator knob points toward the tank which was being used to give you a visual reminder when one tank is empty.

NOTE: The tank in use is not completely empty until the red warning flag is fully visible in the indicator window. The empty tank can be removed for refilling without disturbing the tank being used.

LP TANK COVER

The LP tank cover is easily removed by pulling out the two hair pin clips at each upper corner, then sliding the cover forward until it is free from the front hold down bracket.

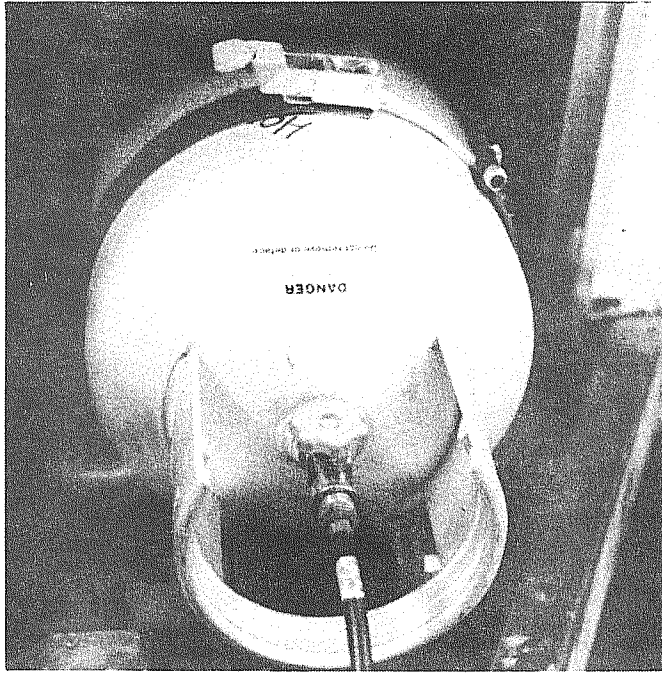

TANK REMOVAL

To remove the tank shut the valve firmly; but, excessive pressure should not be required. Next remove the hose connection at the valve.

NOTE: The LP hose connection has a left-hand thread. Turn clockwise to remove.

A tubing wrench or box end wrench is recommended. Pliers should never be used, and even expensive adjustable wrenches will damage the fitting if not perfectly adjusted.

Raise the latch handle on the hold down strap until the hook can be freed. After noting the direction the bottles are turned, lift up slightly and roll out until it can be lifted clear of the trailer frame.

WARNING: YOUR LP TANKS MUST BE FILLED AS DIRECTED BY THE TANK MANUFACTURER. INSTRUCTIONS ARE LOCATED ON A DECAL NEAR THE FILL VALVE. THE DECAL MUST NOT BE DEFACED.

WARNING: Your LP tank must be, and can only be, placed in the proper position when remounting on the front of the trailer. In any other position the base of the tank will not fit into the recess.

WARNING: Only use the gas bottles furnished with your trailer. If replacement is required it must be a bottle of the same size and design.

WARNING: The vent at the bottom of the regulator must be kept free of any obstructions and must be pointed downward. A good habit is to check the vent each time a bottle is removed for filling. It is especially important to check the vent if the trailer has not been used regularly.

If you have allowed both tanks to run out, air may have gotten into the lines. In this event, the air must be forced out through the lines by gas pressure before you will be able to light the pilots. Hold a match to the pilot of the appliance closest to the tanks until it lights and stays lit. Then move to the next closest, etc.

Twice a year, or after a long storage period, we suggest you take your unit in for a checkup and cleaning of the gas operated appliances.

BASIC RULES FOR SAFETY

WARNING: DO NOT store LP containers within vehicle. LP containers are equipped with safety devices that vent gas should the pressure become excessive.

WARNING: DO NOT use cooking appliances for comfort heating. Cooling appliances need fresh air for safe operation. Before operation open overhead vent or turn on exhaust fan and open window.

A warning label has been located in the cooking area to remind you to provide an adequate supply of fresh air for combustion. Unlike homes, the amount of oxygen supply is limited due to the size of the recreational vehicle, and proper ventilation when using the cooking appliance(s) will avoid dangers of asphyxiation. It is especially important that cooking appliances not be used for comfort heating as the danger of asphyxiation is greater when the appliance is used for long periods of time.

WARNING: Portable fuel-burning equipment, including wood and charcoal grills and stoves, shall not be used inside the recreational vehicle. The use of this equipment inside the recreational vehicle may cause fires or asphyxiation.

WARNING: A warning label has been located near the LP gas container. This label reads: DO NOT FILL CONTAINER(S) TO MORE THAN 80 PERCENT OF CAPACITY.

Overfilling the LP container can result in uncontrolled gas flow which can cause fire or explosion. A properly filled container will contain approximately 80 percent of its volume as liquid LP gas.

WARNING: DO NOT bring or store LP gas containers, gasoline or other flammable liquids inside the vehicle because a fire or explosion may result.

WARNING:

IF YOU SMELL GAS:

1. Extinguish any open flames, pilot lights and all smoking materials.
2. Do not touch electrical switches.
3. Shut off the gas supply at the tank valve(s) or gas supply connection.
4. Open doors and other ventilating openings.
5. Leave the area until odor clears.
6. Have the gas system checked and leakage source corrected before using again.

WARNING: LP gas regulators must always be installed with the diaphragm vent facing downward. Regulators that are not in compartments have been equipped with a protective cover. Make sure that regulator vent faces downward and that cover is kept in place to minimize vent blockage which could result in excessive gas pressure causing fire or explosion.

LP SYSTEM PARTS DIAGRAM (Typical, may vary from model to model)

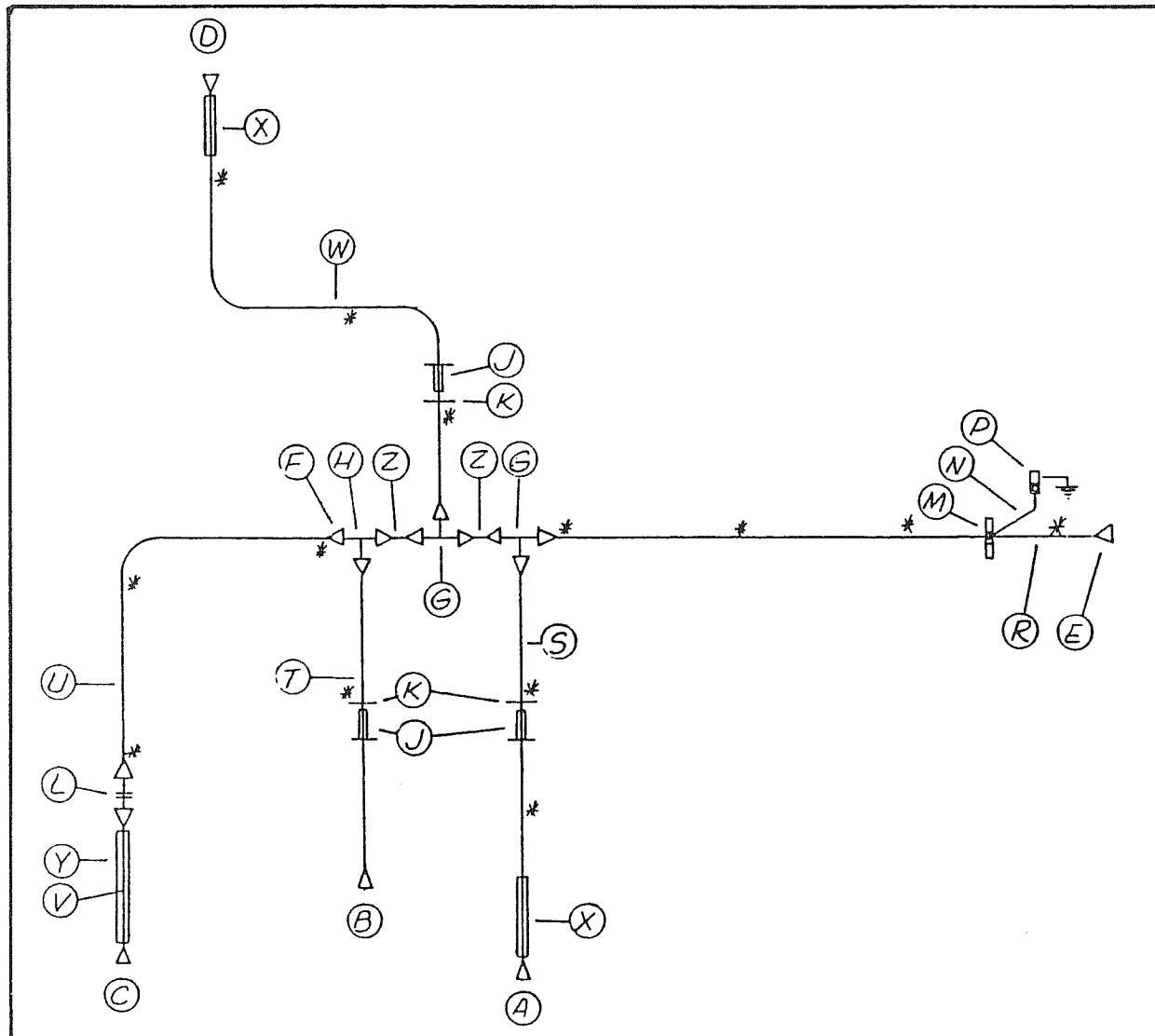

PARTS DESCRIPTION FOR PRECEDING PAGE

- A. Range
- B. Refrigerator
- C. Furnace
- D. Water Heater
- E. 5/8 flare nut
- F. 3/8 flare nut
- G. 5/8 x 5/8 x 3/8 brass tee
- H. 5/8 x 3/8 x 3/8 brass tee
- J. Floor grommet
- K. Underbelly grommet
- L. 3/8 x 3/8 Brass coupler
- M. Ground clamp
- N. #8 bare copper x 12"
- P. Ground lug
- R. 5/8 OD x 156" copper
- S. 3/8 OD x 80" copper
- T. 3/8 OD x 30" copper
- U. 3/8 OD x 83" copper
- V. 3/8 OD x 110" copper
- W. 3/8 OD x 150" copper
- X. Sheathing x 12"
- Y. Sheathing x 24"
- Z. 5/8 OD x 4" copper

WATER SYSTEM - SELF CONTAINED

Fill the water tank by opening the exterior access door, remove screw cap and pull the vent plug. A garden hose can now be inserted. It's a good idea to let the water run through the hose for a short time to flush it out. Experienced RVers usually fill their tanks with "home" water to avoid strange water that may be distasteful to them.

The amount of water in the tank may be checked on the Monitor Panel, or you may fill the tank until water overflows out of the fill.

Open the hot side of the galley or lavatory faucet and turn on the water pump switch located on the monitor panel. For some time the open faucet will only sputter. This is because the water heater is being filled and air is being pushed out through the lines. Once the water heater is full a steady stream of water will come from the faucet. Now open a cold faucet. It will sputter for a short time, but will soon expel a steady stream. All other faucets can now be opened until all air is expelled.

Once the system is filled with water and the faucets closed, the water pump will shut off. When a faucet is opened the pump will come back on automatically. If the faucet is just barely open it is normal for the pump to cycle on and off rapidly.

CAUTION: The water pump must be turned off when hooked up to city water supply and when you leave your Argosy unattended.

WATER PUMP AND FILTER

The water pump and filter are located under the refrigerator. The filter screen should be cleaned periodically to prevent accumulation of dirt and sand. To remove the screen disconnect the rubber hoses from both ends, separate the screen housing, remove the screen, clean and replace.

CLEANING THE TANK

To clean the tank pour some bicarbonate of soda into the filler spout with several gallons of water and allow to stand for a minimum of four hours. Then flush the tank out by opening a faucet, allowing the water pump to drain the system. Then refill with fresh drinking water. If the water tank must be cleaned further the following procedure is recommended.

1. Prepare a sodium hypochlorite solution using potable water and household bleach (5 1/4 to 6%) in a ratio of 1/4 cup of bleach to one gallon of water. (Common household bleaches are Purex and Chlorox.)

2. Pour 1 gallon of hypochlorite solution for each 15 gallons of capacity into the empty water tank.
3. Add enough potable water to completely fill the water system.
4. Allow closed system to stand for three hours.
5. Drain the hypochlorite solution from the system and refill with potable water.
6. Excessive hypochlorite taste or odor remaining in the water system is removed by rinsing the system with a vinegar solution mixed in a ratio of 1 quart of vinegar to 5 gallons of water.
7. Drain the system and flush with fresh drinking water.
8. Drain the system and refill with fresh drinking water.

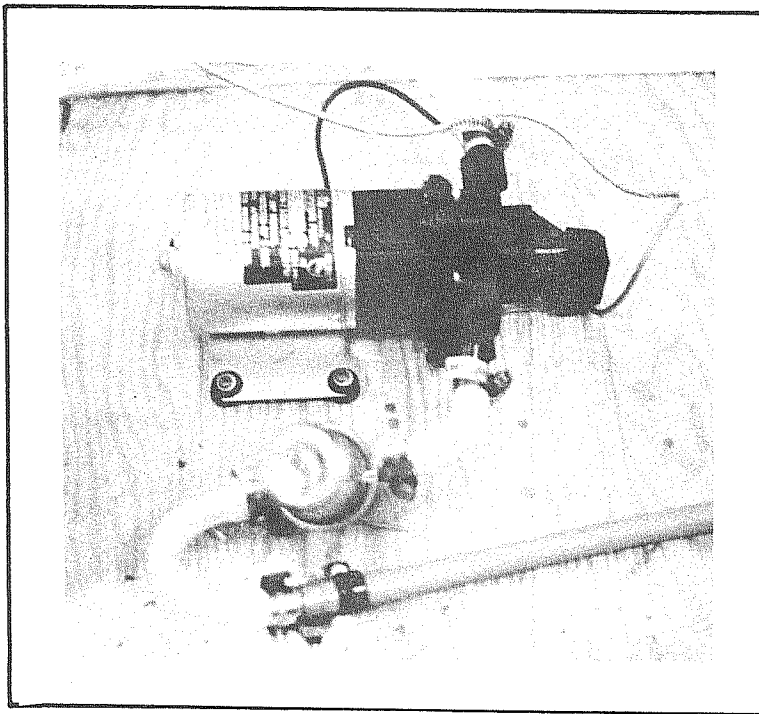

Water Pump

WATER PUMP

Manufacturer: Shur-Flo
1740 Markle Street
Elkhart, Indiana 46514
Phone: 219-294-7581

PARTS DESCRIPTION

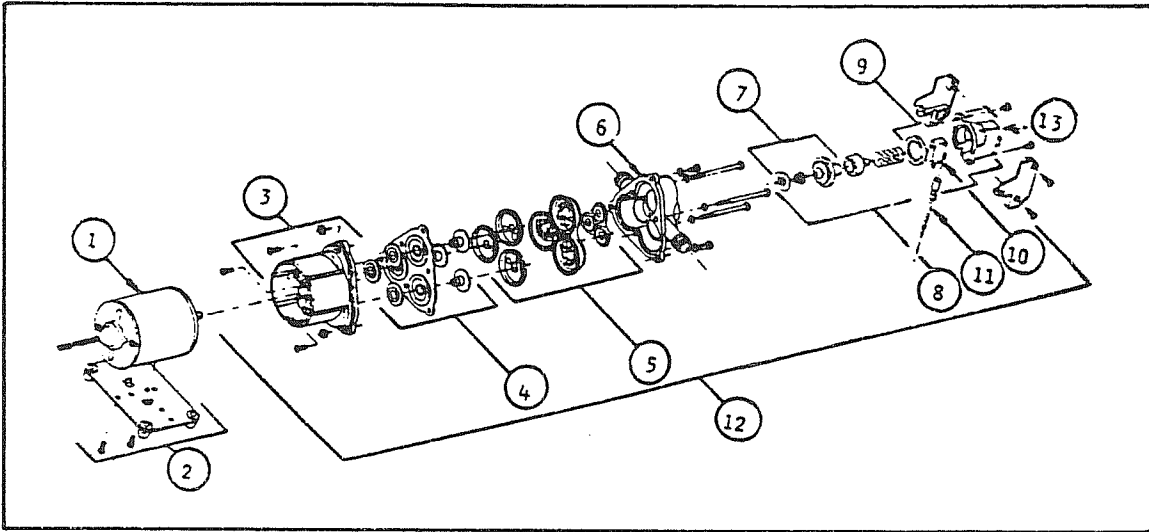

1. Motor
2. Backplate kit
3. Lower Housing Assembly
4. Diaphragm kit
5. Valve assembly kit
6. Upper housing
7. Switching diaphragm kit
8. Switching and switch cap kit
9. Switch cap kit
10. Switch
11. Pigtail
12. Pump head replacement
13. Switch cap only

SWITCH AND CHECK VALVE REPAIR

The check valve, hydraulic switch mechanism and micro switch are accessible by removing the switch cover.

CAUTION: Care should be taken in removing the switch cover screws. Within the mechanism is a spring under compression.

REPLACEMENT OF MICRO SWITCH

Occasionally the micro switch fails or an electrode is broken off. Proceed as follows: Remove the two screws holding the cap to the main body. Remember a spring under compression is retained by this cap. With both screws out, allow the spring to extend fully. Then carefully lift off cap and spring. If only the micro switch is at fault, avoid disturbing the hydraulic elements remaining in the head. If examination of the hydraulic parts is required, remove them carefully by pulling. Be sure to note the order of removal.

To replace the micro switch remove the spring and pull out the black retaining ring. This will allow the micro switch to fall free. Replace parts in the reverse sequence: micro switch, black retainer and the spring.

Reassemble cover to the main body. Switch cap may be pointed up or down as desired, providing wire has not been shortened.

Having replaced the micro switch be careful to rewire correctly.

NOTE: If the positive wire from the battery is connected to the "B" terminal the switch is bypassed and the pump cannot shut off.

Pressure will build up until the motor stalls. If the proper fuse has been used, it will blow. If a larger fuse than recommended has been used, the motor will stall and may burn out.

CHECK VALVE PROBLEMS

Due to contamination from debris or lime build-up the check valve may fail to properly seat. To correct clean out the area and replace the check valve element. If checking the check valve with air, be certain to moisten the check valve to get an accurate check. The rubber seals more effectively when wet.

PROPERLY INSTALLED, THE PUMP WILL:

Prime: The pump will automatically prime itself.

Air-Lock: Pump will not air-lock as the compression stroke is powerful enough to pressurize the entrapped air and force the check valve open.

Run Dry: Pump will run dry for extended periods without damage.

Battery Drain: At free flow the pump draws a mere 7 to 7½ amps.

Check Valve: Built-in check valve prevents back-flow and can protect the pump from the dangers of high city water pressure (up to 200 psi).

Fully Automatic: The pump will automatically come on when the faucet or valve is opened. It delivers a smooth steady flow of water and shuts off automatically when the faucet is closed.

TROUBLE SHOOTING

Motor does not operate.

- Is battery discharged?
- Are any wires disconnected?
- Are terminals corroded?
- Is switch in "ON" position?
- Is fuse good?
- Is water frozen in pump head?

Motor runs but no water flows.

- Is water tank empty?
- Are there kinks in the inlet hose?
- Is air leaking into inlet hose fittings?
- Is inlet line or in-line filter plugged?
- If using a filter, check the line just before the filter.
- Is outlet hose kinked?

Motor runs but water "sputters".

Check to be certain that air has been bled off the lines and water heater. Also check for air leaks in the input side of the pump.

Pump cycles on and off when all outlets are closed.

The pump will normally cycle (go on and off) when a faucet is partially opened. If, however, it cycles when all valves are closed, check for a leak in the lines. It may be a leaky toilet valve or a dripping faucet. Do not forget to check the outside city water entry valve. It may be leaking.

If no leak can be detected, shut pump off. Remove the output hose where it joins the system (not at the pump). Insert a plug in the hose and clamp it. (You can make a perfect plug from a barb fitting. 1/2" size with a cap tightly screwed on the threads.) Turn the pump switch on. The pump should come on, run a few seconds, and then shut off. If it remains off, the problem is NOT the pump. The problem is in the system. If, however, the pump goes on and off there may be a problem in the pump.

There may be an internal leak in the pump which allows water to escape from the high pressure area back into the low pressure area. Look for a pump valve held open or a crack in the plastic parts.

Pump does not achieve shut off.

The wall switch may be used for temporary control of the pump. A low battery charge may be the cause. Or the pump switch mechanism may be stuck. Try tapping the switch cap on the end of the pump with the handle of a screwdriver. If the pump appears in all other respects to run normally, but fails to shut off, you may have to replace the switch mechanism.

Pump head leaks.

If the pump head leaks, first try to tighten the screws in the pump head assembly until they are snug.

CAUTION: Do not overtighten. The leak may be from a crack in the pump head assembly. If so, then replace.

One cause of the pump head cracking may be water freezing inside the pump head. If the leaking water is escaping back near the motor check for a leaking or broken piston.

PUMP REPAIR

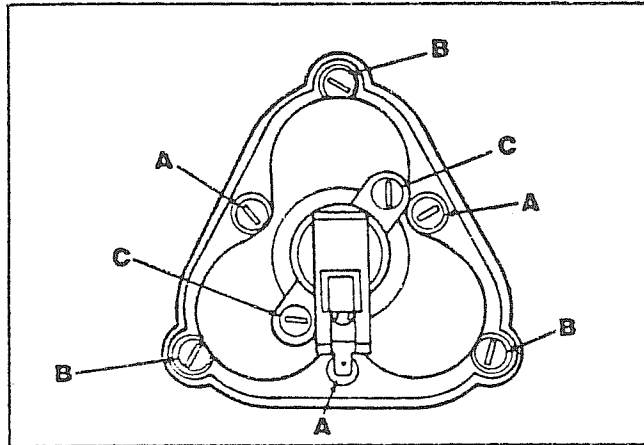

Screws (A) hold the entire pump head assembly to the motor.

Screws (B) hold the pump head face to the pump head main body.

Screws (C) hold the switch assembly to the front of the pump head.

Screws (A) would be removed to correct a problem in the "drive train" between the motor and pump head.

Screws (A) and (B) would be removed to correct a problem in the pump head valves or pumping chambers.

Screws (C) would be removed to correct a problem in the automatic switch or check valve.

PUMP HEAD REPAIR

Motor and drive train area. Rarely does a problem occur in this area of the pump head. If a part does fail, it is quite easily replaced. Just be certain to follow closely the sequence of parts as shown in the figure. Also be careful to align the flat surface in the drive adapter with the flat surface on the motor shaft.

LUBRICATION

If the lubricant appears dried out, it should be wiped off the bearing assemblies. A small amount of automotive wheel bearing grease should be applied to both sides of each bearing.

FAILURE TO PRIME

Failure to prime can be caused by the presence of some foreign matter lodged in the valve preventing it from seating. To correct remove any such foreign bodies.

CAUTION: Do not remove the stainless steel screens. These filter screens should be cleaned without removing them from the plastic housing.

PUMP CHAMBER REPAIR

Replacement of broken piston.

To remove a piston back out the screw holding the defective piston.

Now lift the corner of the diaphragm and remove the broken piston. Insert the new piston through the diaphragm and slide the retaining ring on. Rotate the piston until it drops into place in the drive plate. Replace the screw and tighten until snug.

CAUTION: Do not attempt to re-use a piston once it has been removed. The plastic stem, if used a second time, may not hold securely. The second thread path removes additional material and there is then no real bite.

REPLACE A DIAPHRAGM

To replace a diaphragm follow the procedure used in removing the pistons. After removing the three pistons the diaphragm is loose and easily removed.

Screws (A) hold the piston.

Screws (B) hold the drive mechanism and should not be removed when replacing piston.

WATER PUMP FILTER REMOVAL AND REPLACEMENT

1. With a screwdriver, loosen clamps on both hoses at filter.
2. Remove hoses.
3. Remove screws attaching filter to platform.
4. Remove filter.
5. Replace by reversing above procedure. Note that arrow on side of filter points in direction of flow (toward pump).

DISASSEMBLE PUMP FILTER

1. Remove screw through top.
2. Pull top from base. Do not damage "O" ring seal.
3. Remove screen to clean or replace.
4. Lift "O" ring from its cavity, lubricate with silicone grease.
5. Assemble by reversing above procedure.

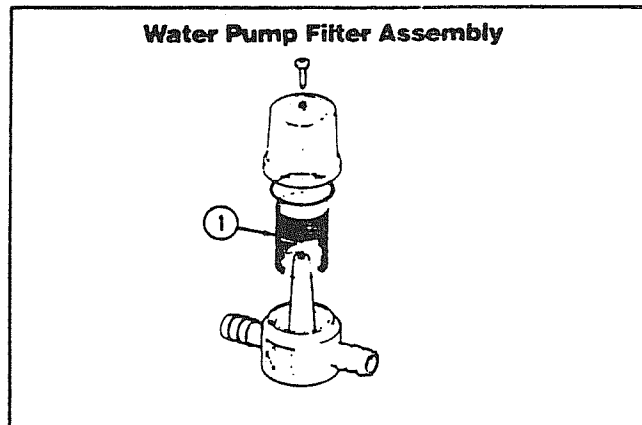

CITY WATER HOOK-UP

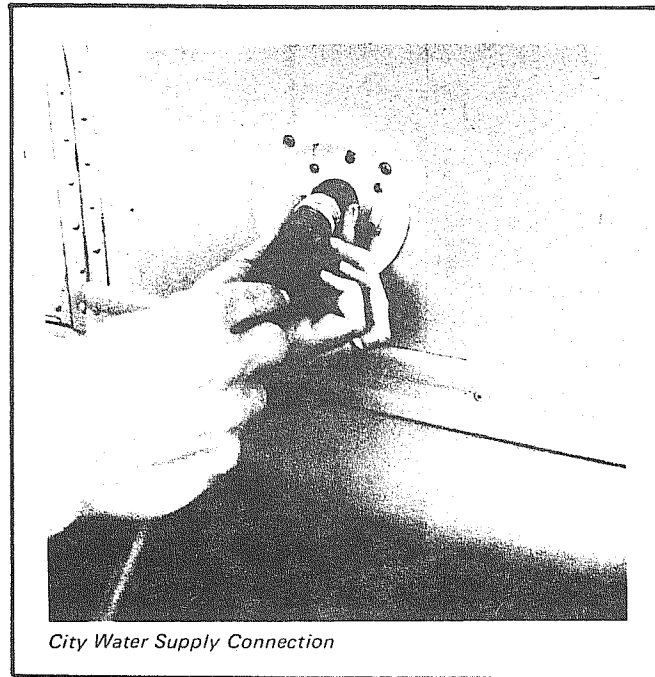

Use a high pressure hose of at least 1/2" diameter. It should be one that is tasteless, odorless and non-toxic designed for RV use. The city water inlet is a standard garden hose thread. We suggest you carry two lengths of hose. This way you have the ability to reach hook-ups further away than normal, plus you have a spare hose should one fail or become damaged unexpectedly.

After hooking up the hose and turning on the city water valve provided in the park, slowly open a faucet. There will be a lot of spurts and sputtering until all the air is expelled from the trailer system. If the water heater is empty it will take some time before all the air is expelled and you get a steady flow of water at the faucet. Once a steady flow is achieved at one faucet the others should be opened long enough to expel the air in the lines going to them.

During city water operation the water pump switch should be in the off position. A check valve built into the pump protects it from city water pressure.

Your plumbing system has a built in pressure regulator to protect your lines and faucets from extremely high pressures on some city water systems.

FAUCETS

CARE AND CLEANING

The surface of the faucets will stay bright and resist wear with a minimum of care. Strong detergents may tend to dull the finish. So, when cleaning a faucet use only mild soap and water.

The finish on the faucets has been designed to retain its polished appearance without scouring. Stains and dirt remove easily without the use of scouring powders or abrasive polishes and cleaners. Use of such agents may cause scratches which mar the finish and in time become dirt catches and unattractive.

CARTRIDGE ADJUSTMENT - GALLEY AND LAVATORY

1. Remove the decorative button and handle with Phillips screwdriver.
2. Position the cartridge in the "off position (fully forward).
3. Insert a 5/64" Allen wrench into the left-hand hole (hot side) in the top of the cartridge. Turn clockwise until a moderate flow appears. Let it run for approximately 2 minutes. If no flow appears the wrench has not properly engaged the cartridge stem.
4. Slowly turn the wrench counterclockwise until the flow stops. Then turn an additional 1/4 turn counterclockwise. Do not push down on the stem during this adjustment. Remove the wrench.
5. Repeat steps 2, 3, and 4 for right-hand (cold) side.
6. Replace parts removed in #1 above.
7. The cartridge is now properly adjusted.

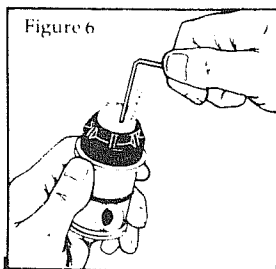

CARTRIDGE ADJUSTMENT - SHOWER

1. Remove the handle (pull off).
2. Position the cartridge in the "off" position.
3. Insert a 5/64" Allen wrench into the left-hand hole (hot side) in the top of the cartridge. Turn clockwise until a moderate flow appears. Let it run for approximately 2 minutes. If no flow appears, the wrench has not properly engaged the cartridge stem.
4. Slowly turn the wrench counterclockwise until the flow stops. Then turn an additional 1/4 turn counterclockwise. Do not push down on the stem during this adjustment. Remove the wrench.
5. Repeat steps 2, 3, and 4 for right-hand (cold) side.
6. Replace parts removed in #1 above.
7. The cartridge is now properly adjusted.

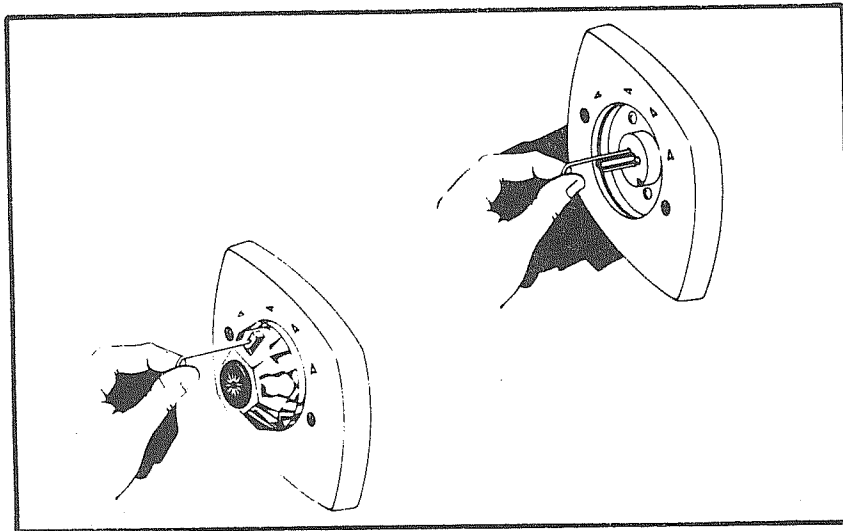

COMFORT AND SAFETY STOPS

The tub/shower unit is equipped with "comfort" and "safety" stop features which are set in the full hot positions. To reposition the "comfort" stop, turn handle to full hot, insert 5/64 Allen wrench through hole in black button and engage hex screw below. Turn counterclockwise to loosen. With Allen wrench still inserted, move handle to desired setting and tighten. Repeat these procedures to position "safety" stop. To override comfort stop push black button.

CARTRIDGE REPLACEMENT - GALLEY AND LAVATORY

Should any maintenance ever be necessary on your faucet you can do that yourself by simple cartridge replacement. Repair kits are available from your dealer. Tools: 1/8" Allen wrench, screwdriver (Phillips), screwdriver (blade), pocket knife, large pliers, clean rag. Before starting to repair your faucet refer to Parts Identification list for proper identification and nomenclature. Follow these steps:

1. Shut off water supply, close drain to prevent loss of small parts.
2. Remove handle button (1). Remove screw (2) and lift off handle (3 or 4). Figure 10.
3. Carefully note the position of the handle adapter (5) to insure correct reassembly. Loosen handle adapter set screw (6) with Allen wrench. Remove handle adapter. Figure 11.
4. Lift off decorative cap (7).
5. Loosen and remove brass hold down ring (8).
6. Remove cartridge (9). Pry cartridge out of body using a screwdriver in front of body. Figure 12.
7. To install new cartridge, open valve before inserting cartridge in underbody by pushing stem forward. Note that cartridge will seat only in one position. The tabs on cartridge must seat in slots on underbody.
8. Replace and securely tighten brass hold down ring.
9. Replace decorative cap with tab resing in the slot provided in the top of the cartridge.
10. Replace handle adapter and tighten the set screw securely. (Note: The set screw must be positioned toward the front of the faucet, so that when tightened it comes in contact with flat space on the cartridge stem.)
11. Replace handle and handle screw and tighten. Snap in handle button.

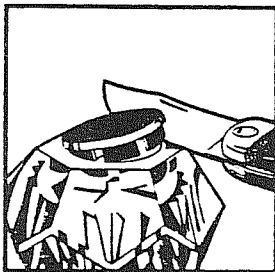

Figure 10

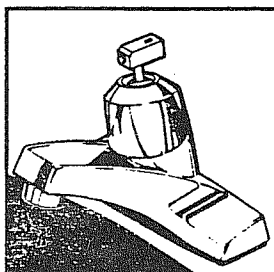

Figure 11

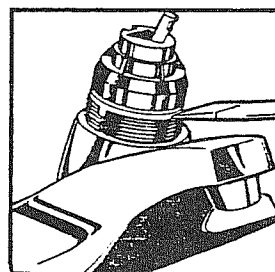

Figure 12

TO CLEAN OR REPLACE SPOUT AERATOR

1. Remove carefully by turning aerator clockwise when facing the installed faucet.
2. Clean aerator and replace. Hand tighten.

CARTRIDGE REPLACEMENT - SHOWER

1. Shut off water. Grasp acrylic handle and pull slowly to remove. Handle is a sliding spring fit with the handle shaft.
2. Use screwdriver to remove cover screws.
3. Remove cover and back-up plate.
4. Loosen and remove brass ring.
5. Turn handle shaft to full open position (counter clockwise).
6. Using blade screwdriver in slot on top of cartridge, carefully pry cartridge out of underbody.
7. Rotate handle shaft on new cartridge to full open position.
8. With screwdriver slot on new cartridge up, insert cartridge into underbody. Note that tabs on cartridge must enter slots in underbody.
9. Replace and securely tighten brass ring. Install back-up plate and cover. Install screws securely, but do not overtighten.
10. Turn handle shaft to off position (clockwise).
11. Replace acrylic handle with comfort stop button in the downward (5 O'Clock) position.
12. Turn on water. Turn handle to comfort stop and thoroughly flush lines for at least one minute.
13. Turn handle to the off position. Control unit is now ready for use.

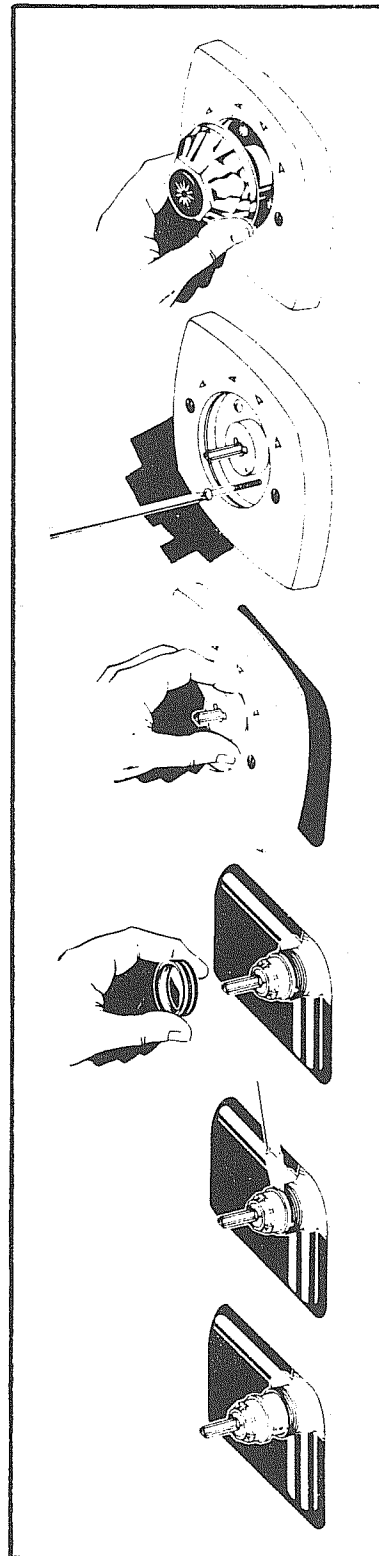

LAVATORY FAUCET PARTS DIAGRAM

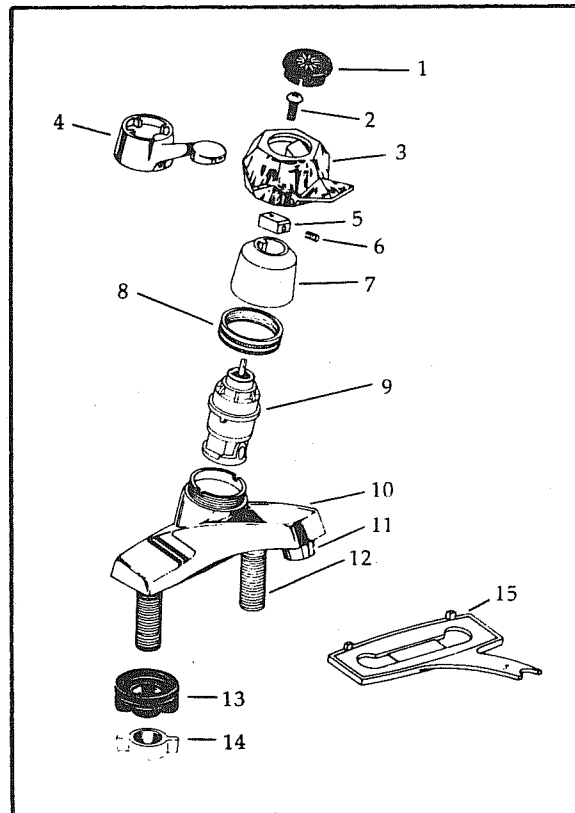

1. Handle button
2. Handle screw
3. Acrylic handle
4. Lever handle
5. Handle adapter
6. Set screw
7. Decorative cap
8. Hold down ring
9. Cartridge
10. Plated cover
11. Aerator (flow control)
12. Underbody
13. Lock nut
14. Coupling nut
15. Putty plate

GALLEY FAUCET PARTS DIAGRAM

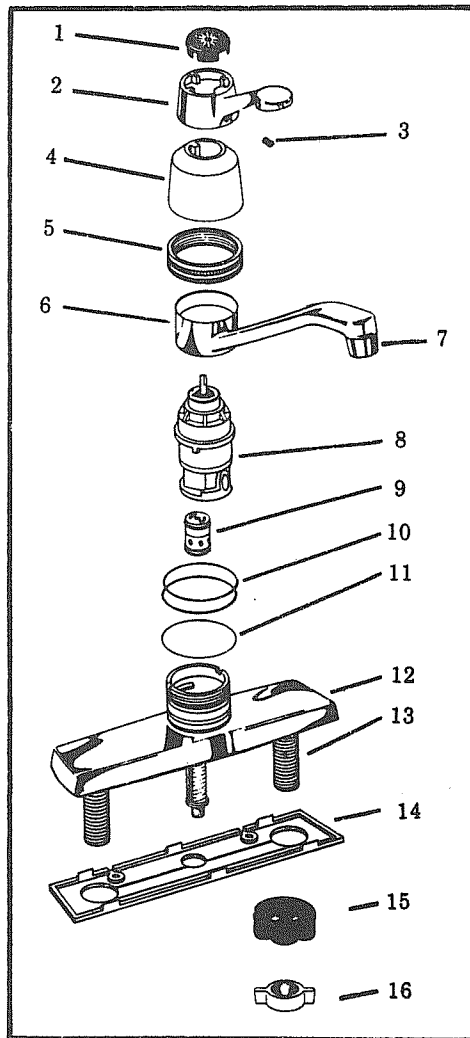

1. Handle button
2. Handle
3. Set screw
4. Decorative cap
5. Hold down ring
6. Spout
7. Aerator (flow control)
8. Cartridge
9. Diverter
10. Hub "O" ring
11. Friction washer
12. Cover
13. Underbody
14. Putty plate
15. Lock nut
16. Coupling nut

SHOWER CONTROL PARTS DIAGRAM

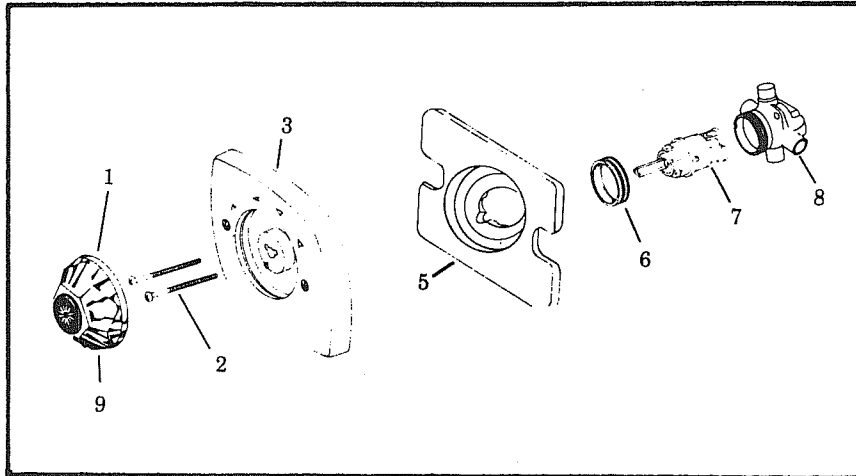

1. Handle
2. Cover screw
3. Stop ring and cover assembly
5. Support plate
6. Hold down ring
7. Cartridge
8. Underbody
9. Handle button

TELEPHONE SHOWER HEAD

The telephone shower head is designed to give maximum flexibility in usage and provides for water saving techniques when using your trailer on self containment. It can be held in the hand and moved about the body. Normally the best water conservation procedure is to wet the entire body and then turn the water off. Apply soap, lather thoroughly, then rinse the soap off. The telephone shower head is also used to fill the tub for taking a bath. When you have finished using the shower be sure to shut the water off at the faucet.

DRAIN VALVES

The Land Yacht has four drain valves.

1. Water heater: A plug or petcock is located on the face of the heater to the left of the main control.
2. Fresh water tank: The fresh water tank has a drain valve that can be seen from outside the trailer as you look between the tires.
3. Line drains: Both hot and cold water lines have drain valves.

DRAIN VALVES

Directly below is an illustration of a line drain valve used by Land Yacht. They are made out of a gray nylon material.

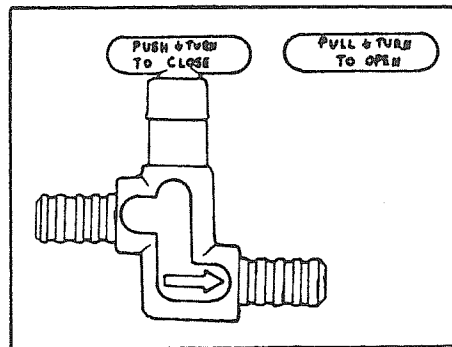

The valves are opened by pulling up on the handles while turning them counterclockwise. About five complete turns will open them completely. To close, push down and turn clockwise about five complete turns.

NOTE: These valves do not have stops. You can just keep turning them.

DRAIN VALVE LOCATIONS - INDICATED BY 

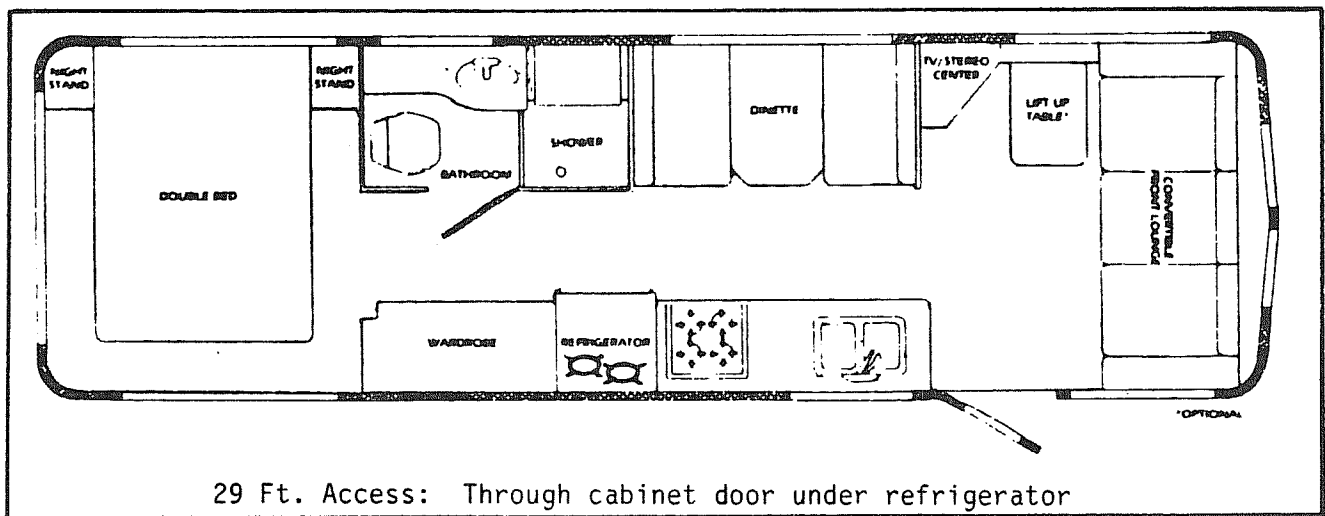
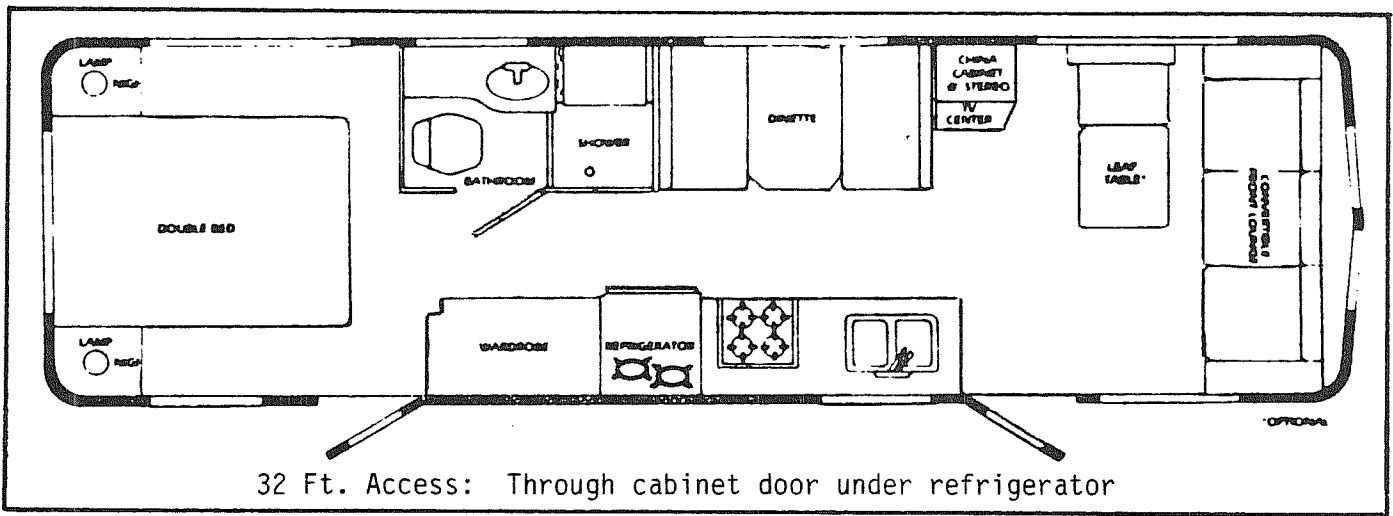
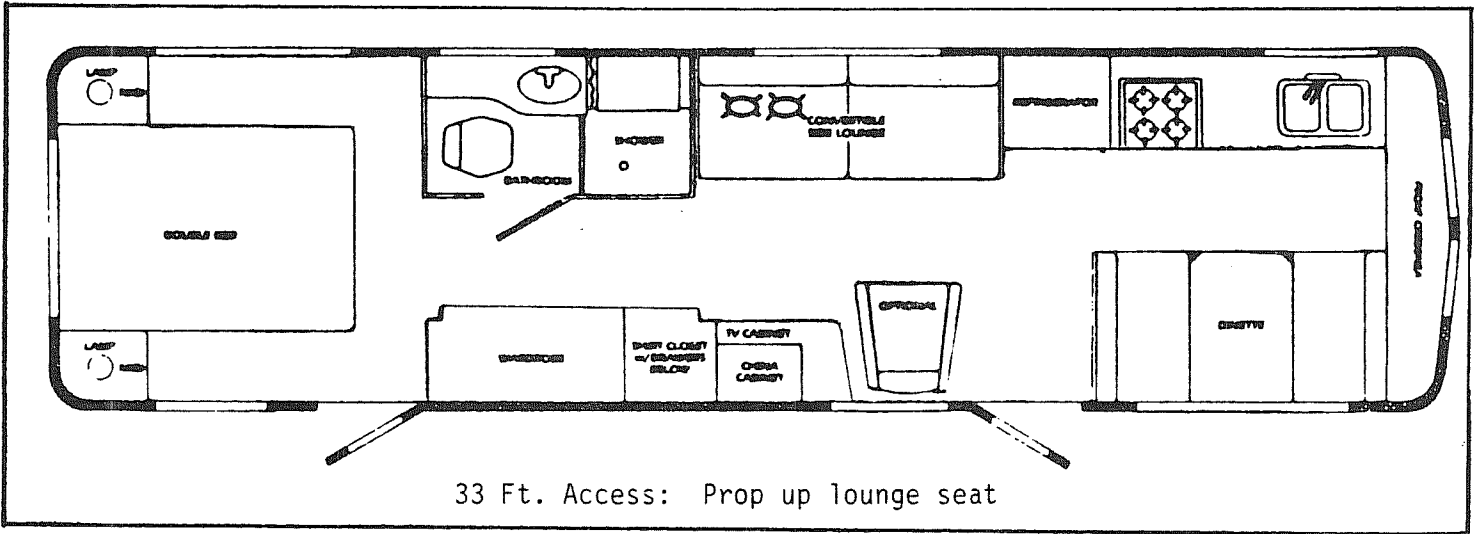

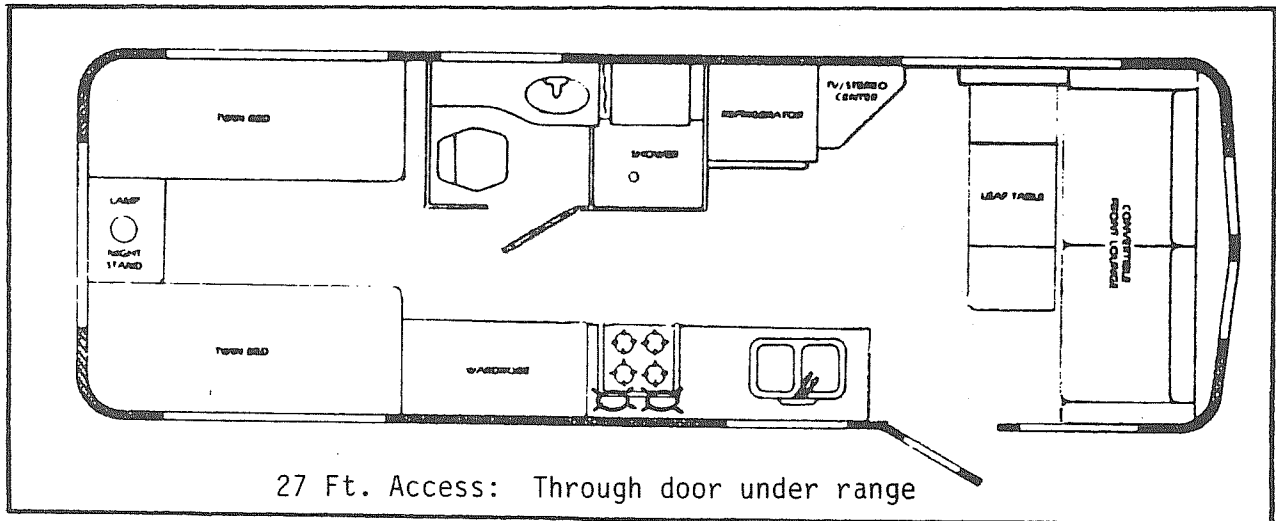

WATER HEATER BY-PASS

All Land Yachts have a water heater by-pass system for use when winterizing. The system is made up of three valves and an additional line running between hot and cold lines. In the 27 ft. model the valves are accessible through the exterior storage compartment door directly behind the water heater. All other models have a small access door in the cabinet beneath the lavatory sink. The valves are located just to the left of the access door.

To by-pass the water heater for winterizing, close valves A and C and open valve B (See Illustration).

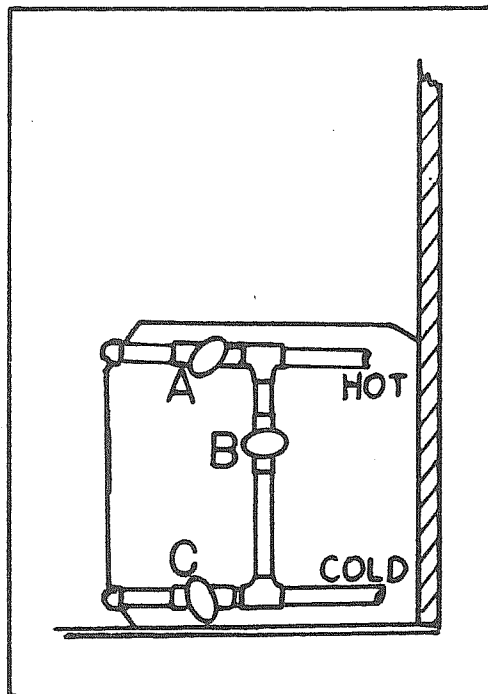

WINTERIZING AND STORAGE

When storing your trailer for short or long periods, use the same precautions as you would in your own home in regard to perishables, ventilation and rain protection. In addition, for prolonged storage periods, flush out all the drain lines and the holding tanks. Also drain the entire water system including the water heater and the water storage tank. Instructions for draining the water system are explained in the following paragraphs on winterizing.

THE MAIN CONSIDERATION IN WINTERIZING IS TO GUARD AGAINST FREEZING DAMAGE TO THE HOT AND COLD WATER SYSTEMS, THE WASTE DRAIN SYSTEM (INCLUDING THE TRAPS), THE WATER HOLDING TANKS, THE WATER HEATER AND THE BATTERY.

To completely winterize your trailer follow this procedure:

1. Level the trailer from side to side and front to rear. Open all faucets.
2. Turn the water pump switch to the ON position to expel water from storage tank.
3. Open all drain valves including drain plug or valve on water heater.
4. By-pass the water heater. (See instructions on prior page.)
5. While the water is draining from the system, open and flush the toilet flushing valve. Depress hand spray lever while holding the spray head down inside the bowl. Depress hand spray thumb button on the telephone shower head while holding down inside the tub and drain all water from the flexible hose. Unscrew the heads on both spray units and store.
6. After all water has been removed from the storage tank, turn the pump switch OFF.
7. Remove exhaust hose from water pump.
8. Disconnect the water pump inlet connection and turn the pump on until all the water is expelled. This water, about 1/2 cup, can be caught in a towel or rag.
9. Lower the front of the trailer as far as the jack will allow until water ceases to drain, then crank the jack up as high as it will go and let any remaining water drain out.
10. After the water has stopped running from the drain lines, apply at least 60 lbs. of air pressure at the city water inlet. An air to city water adapter is available from your dealer's RV accessory store. Be sure the toilet valve and all drain valves and faucets are open, and pump outlet hose is disconnected. This can be accomplished at a service station, and will force any remaining water from the water heater and remove any water which may be trapped in low areas.

11. Pour a cup of approved* non-toxic antifreeze into the lavatory, sink and tub drains to prevent trap freeze-up.

* Approved and listed by a recognized testing authority such as UL (Underwriter Lab).
12. Be sure to open the waste holding tank drain valves and drain and flush the tanks thoroughly (THIS IS VERY IMPORTANT AS THE SEWAGE IN THE TANKS, IF FROZEN, COULD SERIOUSLY DAMAGE THE TANKS.)
13. Remove the cartridge of the water purifier and leave the purifier valve in the open position. (If so equipped.)
14. Remove the batteries from your trailer and store in a cool dry place where there is no danger of freezing. It is very important for optimum life of a battery to check it periodically and to keep it fully charged.
15. Remove any items (food, cosmetics, etc.) from trailer interior that might be damaged by freezing - or might damage the trailer if containers break.

For additional winterizing protection add a non-toxic antifreeze (approved for drinking water system) to the water lines using the following procedure:

1. Reconnect all lines except the hose to the pump inlet port. Close all drain valves (See steps 3 and 12).
2. Attach a length of hose to the pump inlet port. This piece of hose should be long enough for the free end to be inserted into and reach the bottom of the antifreeze container.
3. Dilute the antifreeze solution in accordance with the manufacturer's instructions.
4. Open all water faucets.
5. Insert hose length into the antifreeze container, turn the pump switch on, and run the water pump until the antifreeze solution fills all water lines. Flush toilet, work hand spray while holding down in bowl. Work hand shower spray while holding down in tub.
6. Shut off the pump and close all faucets.
7. Disconnect the hose length from pump inlet fitting and reconnect water system inlet line.

FRESH WATER SYSTEM PARTS DIAGRAM

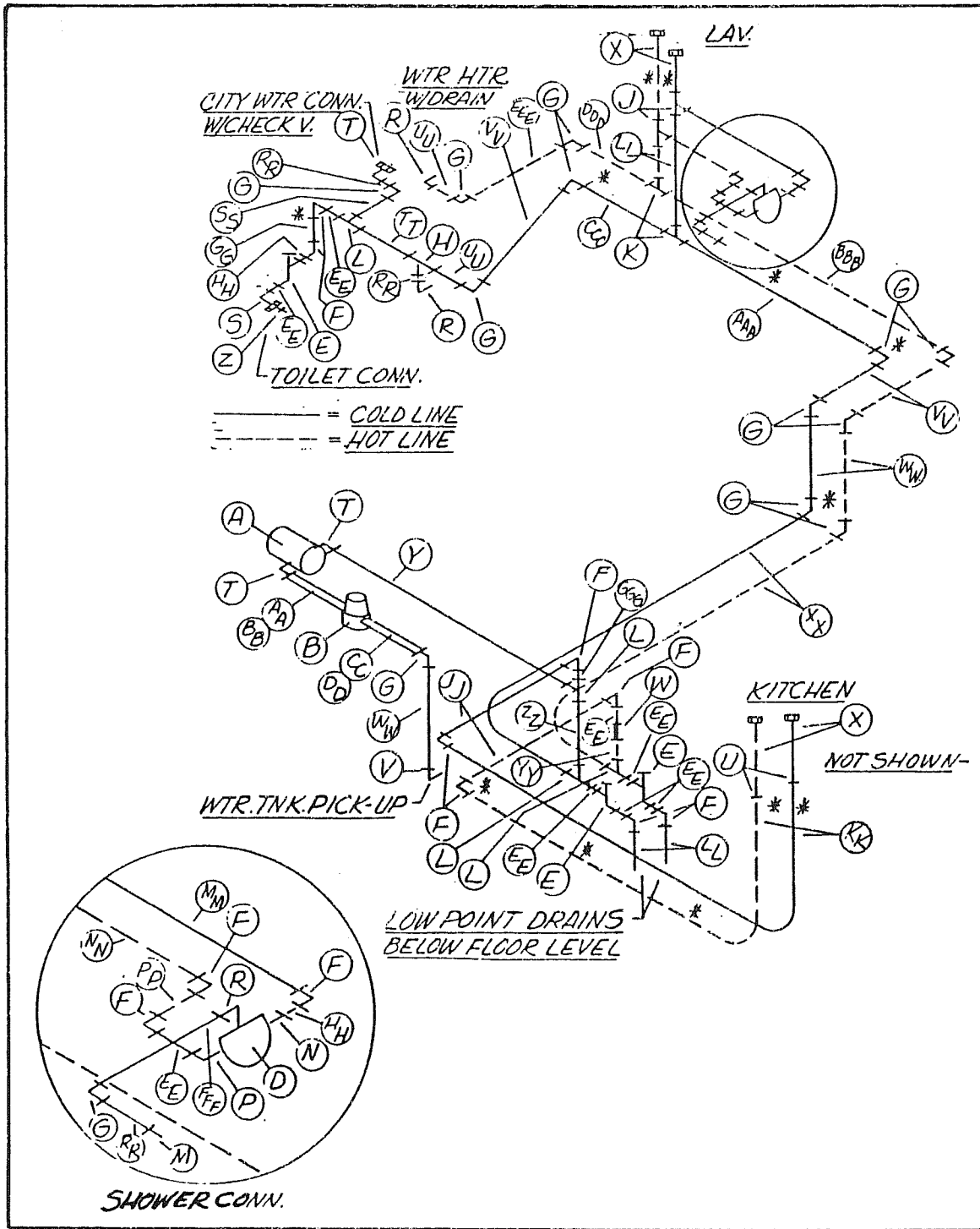

PARTS DESCRIPTION FOR PRECEDING PAGE

- A. Water pump
- B. Water filter
- C. City Water connection
- D. Shower connection
- E. 3/8 shut off valve
- F. 3/8, 90⁰ barb elbow
- G. 1/2, 90⁰ barb elbow
- H. 1/2 barb tee
- J. 3/8 barb tee
- K. 1/2 x 1/2 x 3/8 barb tee
- L. 1/2 x 3/8 x 1/2 barb tee
- M. 1/2 MPT x 1/2 barb coupler
- N. 1/2 MPT x 3/8 barb coupler
- P. 1/2 MPT x 3/8 90⁰ barb ell
- R. 1/2 MPT x 1/2 90⁰ barb ell
- S. Toilet connection
- T. Swivel elbow 90⁰
- U. 3/8 coupler
- V. 3/8 MPT x 1/2 barb 90⁰ ell
- W. 3/8 barb x 1/2 barb coupler
- X. 3/8 ID water line riser
- Z. 3/8 MPT x 1/2 MPT coupler
- AA. 5/8 OD hose x 3 1/2
- BB. Spring (inside) x 4 1/2
- CC. 5/8 OD hose x 4 1/2
- DD. Spring (inside) x 5 1/2
- EE. 3/8" ID x 1 1/2
- GG. 3/8 ID x 4'
- HH. 3/8 ID x 3 1/2
- JJ. 3/8 ID x 17 3/8
- KK. 3/8 ID x 84"
- LL. 3/8 ID x 12"
- MM. 3/8 ID x 9 1/2"
- NN. 3/8 ID x 8"
- PP. 3/8 ID x 10"
- RR. 1/2 ID x 1 1/2"
- SS. 1/2 ID x 11 7/8
- UU. 1/2 ID x 4"
- VV. 1/2 ID x 16"
- WW. 1/2 ID x 12"
- XX. 1/2 ID x 64"
- YY. 1/2 ID x 7 1/2"
- ZZ. 1/2 ID x 1 3/4"
- AAA. 1/2 ID x 37 3/4"
- BBB. 1/2 ID x 40 1/2"
- CCC. 1/2 ID x 6 1/4"
- DDD. 1/2 ID x 3 1/2"
- EEE. 1/2 ID x 12 1/2"
- FFF. 1/2 ID x 4 1/2"
- GGG. 3/8 ID x 6"

FRESH WATER SYSTEM - 33 FT Front Kitchen

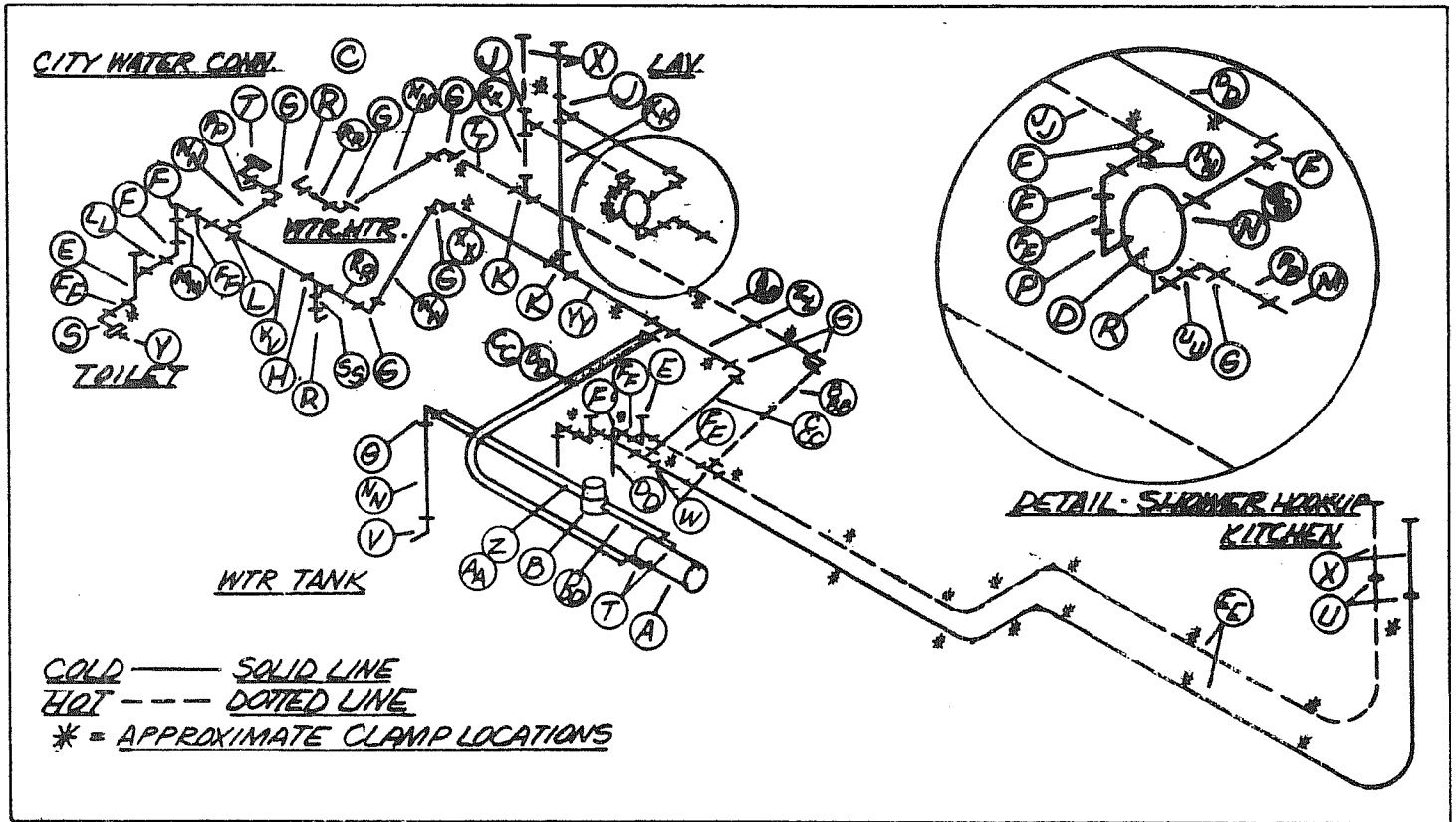

COLD ——— SOLID LINE
HOT - - - - DOTTED LINE
 * = APPROXIMATE CLAMP LOCATIONS

- | | | | |
|----|------------------------------|------|-----------------------|
| A. | Water Pump | AA. | Spring (inside) x 39" |
| B. | Water Filter | BB. | 5/8 OD Hose x 60" |
| C. | City Water Conn. | CC. | Spring (inside) x 61" |
| D. | Shower Valve | DD. | 3/8 ID x 9" |
| E. | 3/8" Shut Off Valve | EE. | 3/8 ID x 168" |
| F. | 3/8" 90° Barb Elbow | FF. | 3.8 ID x 1 1/2" |
| G. | 1/2" 90° Barb Elbow | GG. | 3/8 ID x 5 1/2" |
| H. | 1/2" Barb Tee | HH. | 3/8 Id x 9 1/4" |
| J. | 3/8" Barb Tee | JJ. | 3/8 ID x 11 1/2" |
| K. | 1/2 x 1/2 x 3/8 Barb Tee | KK. | 3/8 ID x 11" |
| L. | 1/2 x 3/8 x 1/2 Barb Tee | LL. | 3/8 ID x 3" |
| M. | 1/2 MPT x 1/2 Barb Coupler | MM. | 3/8 ID x 4" |
| N. | 1/2 MPT x 1/2 Barb Coupler | NN. | 1/2 ID x 12" |
| P. | 1/2 MPT x 3/8 90° Barb Ell | PP. | 1/2 Id x 1 1/2" |
| R. | 1/2 MPT x 1/2 90° Barb Ell | RR. | 1/2 ID x 4" |
| S. | 3/8 Swivel Toilet Conn | SS. | 1/2 ID x 4 1/2" |
| T. | 90° Swivel Elbow | TT. | 1/2 ID x 3 1/2" |
| U. | 3/8 Coupler | UU. | 1/2 ID x 5 1/2" |
| V. | 3/8 MPT x 1/2 Barb 90° Ell | VV. | 1/2 ID x 11" |
| W. | 3/8 x 3/8 x 1/2 Barb 90° Ell | WW. | 1/2 ID x 14" |
| X. | 3/8 ID Water Line Riser | XX. | 1/2 ID x 6" |
| Y. | 3/8 MPT x 1/2 MPT Coupler | YY. | 1/2 ID x 41" |
| Z. | 5/8 OD Hose X 38" | ZZ. | 1/2 ID x 33" |
| | | AAA. | 1/2 ID x 77 1/4" |
| | | BBB. | 1/2 ID x 22 1/2" |
| | | CCC. | 1/2 ID x 21 1/2" |
| | | DDD. | 5/8 OD Hose x 5 1/2" |

DRAIN AND WASTE SYSTEM

Your trailer has a drain and waste system that includes waste holding tanks made from molded plastic, free from corrosion problems, with trouble-free dump valves.

The MAIN HOLDING TANK enables you to use the toilet for several days away from disposal facilities. The waste water from the sink, shower, bath and lavatory drains in the AUXILIARY HOLDING TANK. Each tank has its own dump valve, however, both tanks drain through a common outlet. Therefore, you need to make only one connection when hooking up in a trailer park with sewer facilities.

CAUTION: Never put wet strength paper towels or tissues in your holding tank since they won't dissolve and can "catch" in the mechanism of the dump valve. Colored toilet tissue is slower to dissolve than white. Most RV accessory stores offer tissue designed for RVs that will completely dissolve.

DEODORIZERS

There are many deodorizers on the market in tablet, liquid and powder form. These not only combat odor, but stimulate the bacteria that works to dissolve the solids in your tank.

MONITOR PANEL

Check your monitor panel frequently. When the MAIN HOLDING TANK is completely full, sewage cannot be emptied from the toilet bowl. If the AUXILIARY HOLDING TANK is overfilled, drain water will "backup" into the tub and cause an unpleasant cleaning job. Never drain the tanks at any place other than an approved dumping station.

EMPTYING TANKS

Almost all campgrounds will have dumping facilities. Park directories such as Woodalls and Rand McNally also list dumping stations.

To empty one or both tanks attach the sewer hose by pressing the bayonet fitting onto the dump valve outlet located behind the road-side tires, and rotate clockwise until it feels solid and secure. Attach the outlet end of the hose to the sewage outlet, making sure that the hose is placed so it will drain completely.

Pull the dump valve handle as far as it will go and wait until the tank is drained. When dumping, the main holding tank should be dumped first; then the auxiliary holding tank. This will help to rinse out the sewer line with auxiliary holding tank water.

CAUTION: Be aware that there are two water fills on your Land Yacht. One is used to fill the fresh water tank, and the other is used to flush the black water tank.

DO NOT USE YOUR FRESH WATER HOSE TO FLUSH YOUR BLACK WATER TANK.

The main holding tank must be flushed out until all paper and waste material is removed. Close the dump valve and refill the tank with clean water and repeat until clean. Replace the cap prior to traveling.

WHEN PARKED AND CONNECTED TO SEWER OUTLET

When you are in a park and connected to a sewer outlet keep the main holding tank dump valve closed and empty the tank every few days or whenever it becomes almost full. ONLY BY SENDING A LARGE VOLUME OF LIQUID THROUGH THE MAIN HOLDING TANK AT A TIME WILL TOILET PAPER AND OTHER SOLIDS COMPLETELY WASH AWAY.

This practice will avoid the accumulation of solids in the main holding tank which could lead to an unpleasant cleaning job. Should solids accumulate close the dump valve, fill the tank about half full with water, then tow the trailer for a few miles. The turbulence and surging of the water will usually dissolve the solids into suspension so the tank can be drained. Keep the auxiliary tank valve open when connected to a sewer outlet.

Draining the tanks as described will protect them from freezing during storage. When traveling in sub-freezing temperatures use a winterizing solution designed for RV use. Follow the directions on the container.

DRAIN SYSTEMS CLEANING

The following cleaning agents can be used without causing harm to the system.

1. Naptha
2. Household soaps
3. Soapless detergents
4. Trisodium phosphate
5. Household ammonia
6. 10% hydrochloric acid (solution)
7. 5% sulfuric acid (solution)
8. Hypochlorite bleach (Chlorox)
9. 10% sodium hydroxide (solution)

Never use any other type cleaners unless marked approved for ABS drainage systems.

When winterizing drains use only trailer plumbing system type anti-freeze. (These are sold through your dealer.)

Do not use abrasive cleaners.

CLEANOUT PLUGS

Fittings have been installed to make it easier to clean out the drain lines. The fitting will be "Y" or "T" shaped with a screw-in plug in the offset leg.

There is a WATER FILL POCKET into which you can insert a hose and FLUSH THE BLACK WATER TANK. This pocket is located on the side of the trailer in the vicinity of the wheel well.

DO NOT USE YOUR FRESH WATER HOSE TO FLUSH YOUR BLACK WATER TANK.

DRAIN SYSTEM REPAIR

Fittings are cemented together with ABS corlon cement, and therefore cannot be successfully separated. The section to be repaired must be cut out of the drain system using a hacksaw. Surfaces to be cemented must be clean and dry. Use a small 1/2" paint brush to apply the cement. Fittings must be installed immediately as the cement dries rapidly and bonding action is in seconds. For this reason it is best to have all pieces pre-cut and a trial assembly made without the use of cement.

HOLDING TANK REMOVAL

Both Tanks

1. Drain both holding tanks completely.
2. Remove screws fastening tank pan to bottom of trailer.
3. Loosen hose clamps securing rubber caulder coupling to 3" drain fittings.

Gray Tank (Sink Water)

1. Support tank to prevent it from falling.
2. Remove hose clamps from drain line to tank fittings.

Two fittings are located in the bottom of the large wardrobe. A third fitting is located under the shower. To gain access remove the heat duct and use a sabre type saw to cut out vertical panel. After replacing tank, cover the cut out with a thin false panel.

Black Tank (Sewage)

1. Support tank to prevent it from falling.
2. Remove hose clamp on vent line to tank fitting located in wardrobe to rear of furnace.
3. Remove toilet.
4. Unscrew toilet mounting flange from tank.

NOTE:

To date we are not aware of a glue or glue-type substance that can be used to satisfactorily repair the tanks. There is a hot air type welding procedure that has a fairly good success rate. During warranty the tanks must be replaced, NOT REPAIRED, for dealers to obtain reimbursement.

Progress is still being made in the plastics field and a chemical glue suitable to make repairs may become available.

DRAIN SYSTEM - BELOW FLOOR

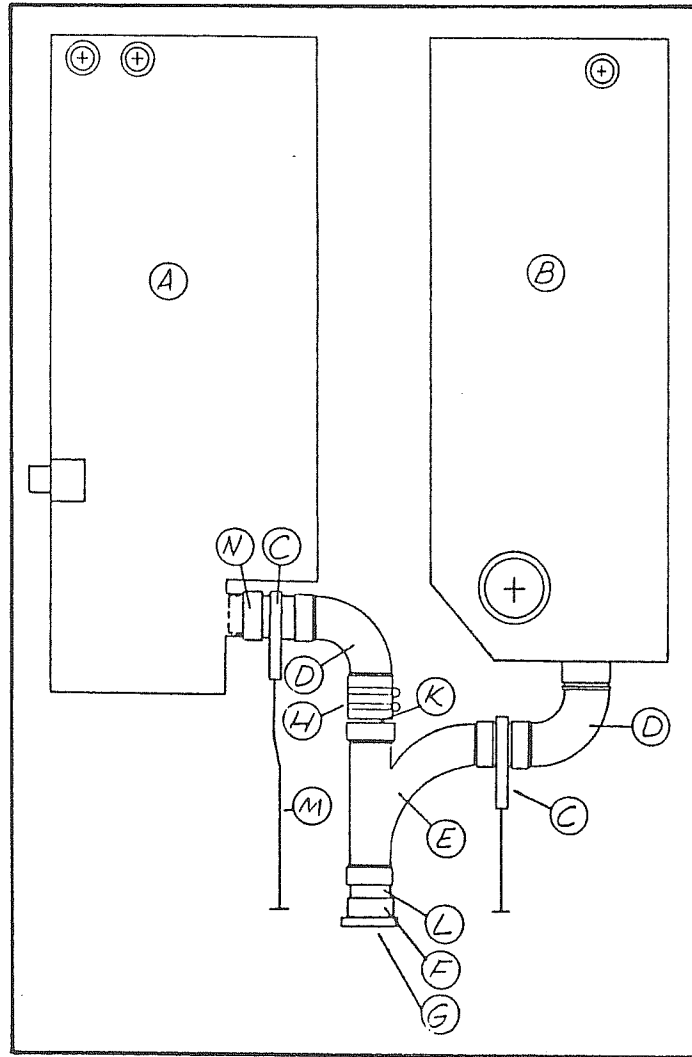

- A. Grey holding tank
- B. Black holding tank
- C. 3" gate valve
- D. 3" XLT, 90° ell
- E. 3" x 3" x 3" wye
- F. Bayonet ring
- G. Bayonet cap
- H. 3" cauldler coupler
- K. 3" dia. x 2 1/2" ABS
- L. 3" dia. x 3 1/2" ABS
- M. Extension handle
- N. Female tank fitting

DRAIN SYSTEM - ABOVE FLOOR (TYPICAL)

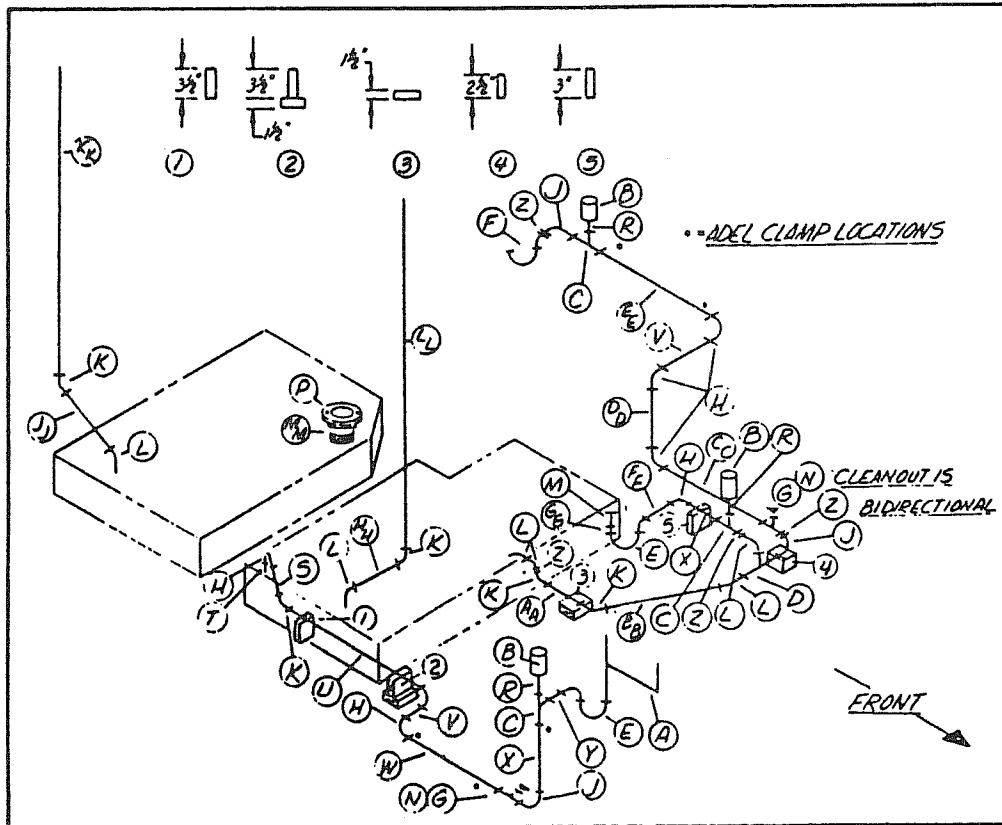

- | | | | |
|----|-------------------------|-----|--------------------|
| A. | Continuous Waste | X. | 1 1/2 dia x 9 1/2 |
| B. | Auto Vent | Y. | 1 1/2 dia x 6 |
| C. | Sanitary Tee 1 1/2" | Z. | 1 1/2 dia x 1 1/2 |
| D. | 1 1/2" 45° Wye | AA. | 1 1/2 dia x 11 1/2 |
| E. | 1 1/2 P-Trap | BB. | 1 1/2 dia x 13 1/4 |
| F. | 1 1/2 P-Trap w/ slip | CC. | 1 1/2 dia x 3 3/8 |
| G. | 1 1/2 Cleanout Tee | DD. | 1 1/2 dia x 7 5/8 |
| H. | 1 1/2 90° XLT Elbow | EE. | 1 1/2 dia x 23 |
| J. | 1 1/2 90° XLT St. Elbow | FF. | 1 1/2 dia x 8 1/2 |
| K. | 1 1/2 45° Elbow | GG. | 1 1/2 dia x 2 1/8 |
| M. | 1 1/2 Swivel Strainer | HH. | 1 1/2 dia x 15 |
| N. | 1 1/2 Cleanout Plug | JJ. | 1 1/2 dia x 5 1/2 |
| P. | 4 x 3 Closet Flange | KK. | 1 1/2 dia x 74 |
| R. | 1 1/2 dia x 3 1/2 | LL. | 1 1/2 dia x 65 |
| S. | 1 1/2 dia x 5 | MM. | 3" dia nipple x 2" |
| T. | 1 1/2 dia x 2 | | |
| U. | 1 1/2 dia x 62 1/4 | | |
| V. | 1 1/2 dia x 5 1/2 | | |
| W. | 1 1/2 dia x 21 1/2 | | |

DRAIN SYSTEM - ABOVE FLOOR (33FT. Front Kitchen)

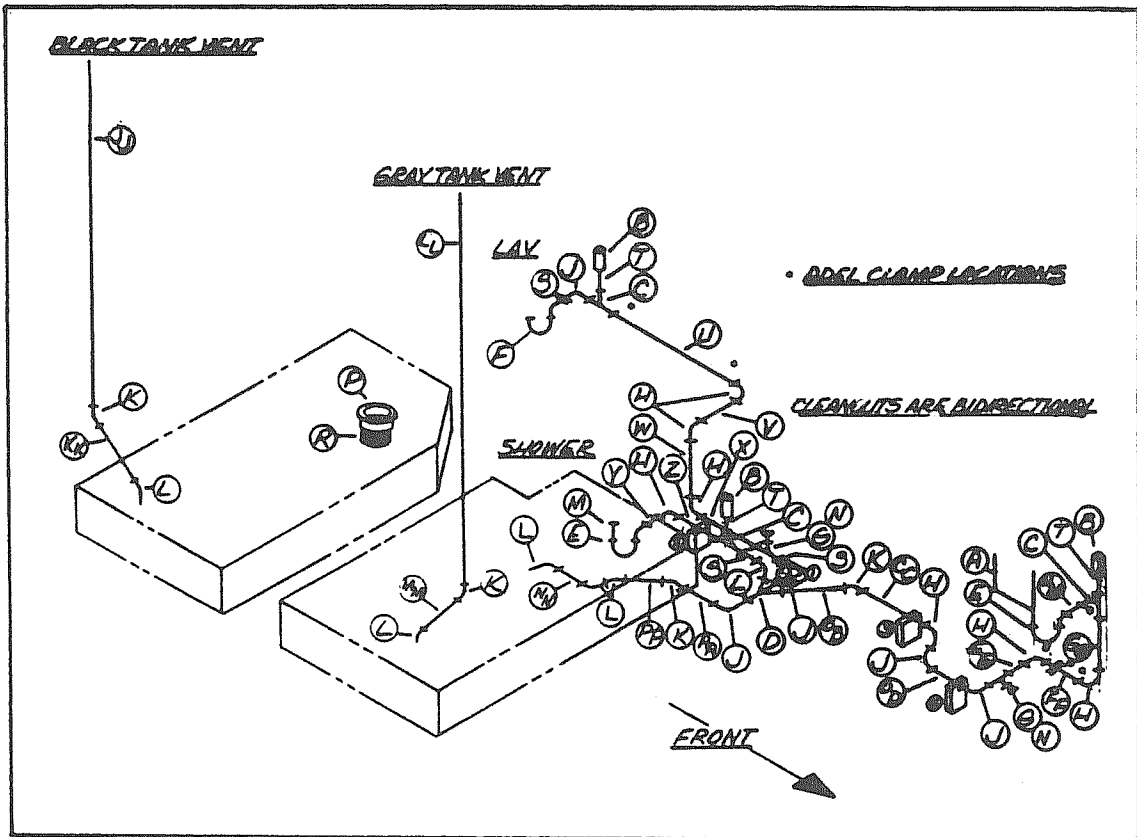

- | | | | |
|----|-------------------------|-----|--------------------|
| A. | Continuous Waste | AA. | 1 1/2 dia x 3 |
| B. | Auto Vent | BB. | 1 1/2 dia x 4 1/2 |
| C. | 1 1/2 San Tee | CC. | 1 1/2 dia x 12 |
| D. | 1 1/2 Double 45° Wye | DD. | 1 1/2 dia x 46 1/2 |
| E. | 1 1/2 P-Trap Hub x Hub | EE. | 1 1/2 dia x 9 1/4 |
| F. | 1 1/2 P-Trap w/ Slip | FF. | 1 1/2 dia x 73 1/2 |
| G. | 1 1/2 Cleanout Tee | GG. | 1 1/2 dia x 11 1/2 |
| H. | 1 1/2 90° XLT Elbow | HH. | 1 1/2 dia x 6 |
| J. | 1 1/2 90° XLT St. Elbow | JJ. | 1 1/2 dia x 74 |
| K. | 1 1/2 45° Elbow | KK. | 1 1/2 dia x 5 1/2 |
| L. | 1 1/2 45° St. Elbow | LL. | 1 1/2 dia x 65 |
| M. | 1 1/2 Swivel Strainer | MM. | 1 1/2 dia x 15 |
| N. | 1 1/2 Cleanout Plug | NN. | 1 1/2 dia x 8 5/8 |
| P. | 4 x 3 Closet Flange | PP. | 1 1/2 dia x 9 1/2 |
| R. | 3" Dia Nipple x 2" | | |
| S. | 1 1/2 dia x 1 1/2 | | |
| T. | 1 1/2 dia x 3 1/2 | | |
| U. | 1 1/2 dia x 26 | | |
| V. | 1 1/2 Dia x 4 3/4 | | |
| W. | 1 1/2 Dia x 10 | | |
| X. | 1 1/2 dia x 3 3/4 | | |
| Y. | 1 1/2 dia x 7 1/2 | | |
| Z. | 1 1/2 Dia. X 12 1/4 | | |

TOILET

The RV toilet in your Land Yacht is a design that has been used for many years. There are two pedals. The large pedal opens and closes the slide mechanism and the smaller pedal opens and closes a water valve.

In normal use, when you are hooked up to city water, both pedals are depressed together. This dumps the sewage and fresh water and flushes down the sides of the bowl. Water will continue to run into the bowl for a short time after the pedals are released.

When you wish to conserve water hold the handspray head over the bowl and hold down the thumb operated lever. Now when you depress the pedal all the water is routed through the handspray.

CAUTION: When you dump the bowl of the toilet make sure all paper and solids have cleared the slide mechanism before you allow it to close. Failure to do so can cause the groove for the slide to become jammed and the slide will no longer close completely.

If the problem should occur a small nail or bent clothes hanger can be used to "pick" the material out of the groove.

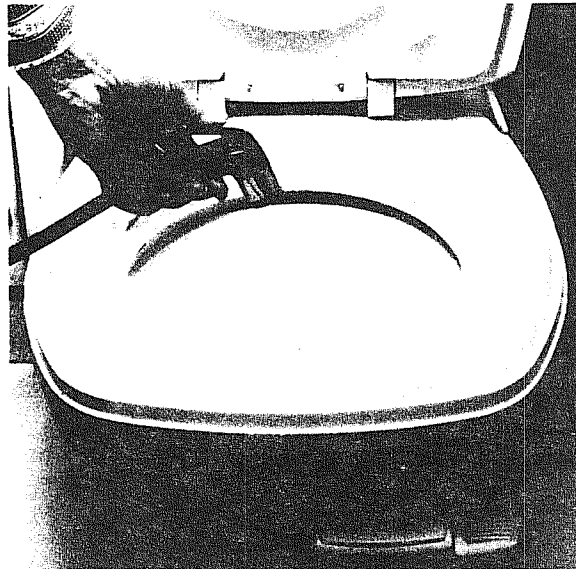

Toilet Hand Spray

TROUBLE SHOOTING

PROBLEM: Water keeps running into bowl.

CAUSE: The blade in the bottom of the bowl is not closing completely, which in turn keeps the water control valve partially open. The groove into which the blade seats when completely closed is clogged with foreign material.

REMEDY: Insert the end of a coat hanger or similar object into the sealing groove and remove the foreign material. Avoid damaging the rubber seal while cleaning.

PROBLEM: Toilet leaks. There is water on the floor. Specify the problem. Determine if water is leaking from:

- a. Vacuum breaker
- b. The water control valve.
- c. Bowl to mechanism seal (if this is the problem the water would not stay in the bowl.)
- d. Closet flange base seal.

REMEDY:

- a. The vacuum breaker. If the vacuum breaker leaks when flushing the toilet, replace vacuum breaker.
- b. If the vacuum breaker leaks when the toilet is not in operation replace the water control valve.
- c. Leaks at the bowl to mechanism seal. Remove mechanism and replace mechanism seal.
- d. Leaks at closet flange area. Check front and rear closet flange nuts for tightness. If leak continues remove the toilet, check the closet flange height. The height should be between 1/4" and 7/16" above the floor. Adjust closet flange height accordingly and replace closet flange seal.

PROBLEM: Foot pedal operates harder than normal, or the blade sticks.

REMEDY:

- a. Apply a light film of Silicone spray to blade.
- b. Check closet bolt tightness. If closet bolts are over tightened the mechanism may be distorted.

PROBLEM: Bowl will not hold water. IE: Water leaks from bowl down into the holding tank.

REMEDY: Using a bent screwdriver or similar object, scrape the groove in front of the mechanism blade. Generally paper or other foreign material is lodged in this groove causing the leak.

CAUTION: Use care not to damage the blade seal. Always make certain that the tool is under the lip of the seal, not above it.

The tool can easily be made by bending a coat hanger or screwdriver over about 7/8".

MAINTENANCE

If the bowl sealing blade does not operate freely after extended use, it may be restored to its original, smooth operating condition by applying a light film of silicone spray to the blade. To clean the toilet use Thetford Aqua Bowl or any other high grade non-toxic abrasive cleaner. Do not use highly concentrated or high acid content household cleaners. They may damage the rubber seals.

REMOVAL

1. Shut off water valve behind toilet or main water supply.
2. Disconnect water supply line from toilet. You will probably find a small mirror very useful.
3. Depress pedal and remove nut located in pedal recess.
4. Reach behind toilet and remove nut on opposite side of base from pedals. In some situations you may want to remove the plug in top of the seat designed to give access from above to this nut.

NOTE: Always replace flange seal when toilet has been removed.

VACUUM BREAKER ASSEMBLY AND DISASSEMBLY

Remove vacuum breaker from toilet. Remove 10 screws holding the cover to the housing. This exposes the vacuum breaker float, float seal and cover seal. The float is free in its chamber and is easily lifted or dumped out.

NOTE: When reassembling the unit make sure the housing is free of dirt and the raised collar that the float sits on is clean and free of burrs.

When the cover is reinstalled it is important that the screws be turned backwards until they jump so that when they are tightened they are in the original thread.

TOILET PARTS DIAGRAM

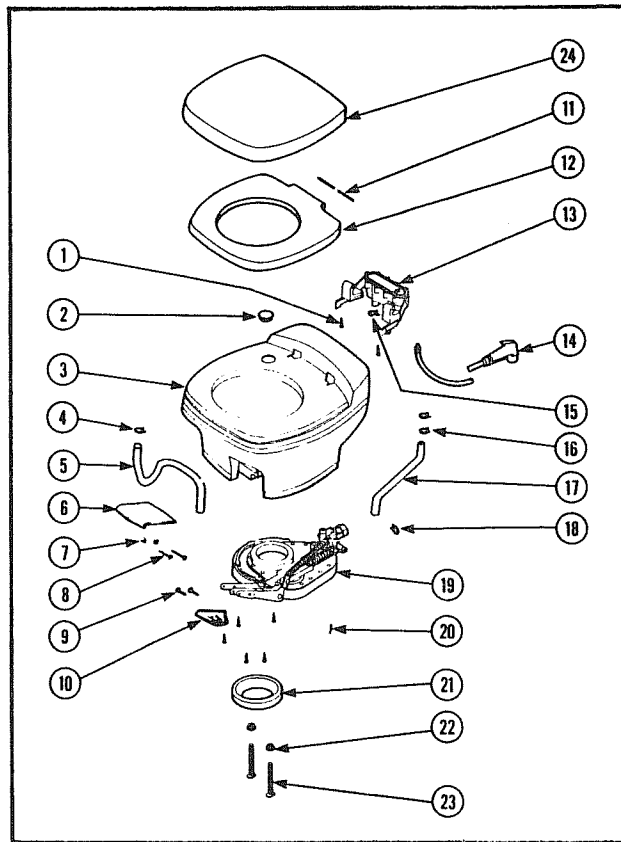

1. Screw
2. Hole plug
3. Hopper assembly
4. Clamp
5. Trap tube
6. Pedal
7. Nut
8. Screw
9. screw
10. Pedal
11. Hinge pin
12. Seat
13. Vacuum breaker assembly
14. Hand spray
15. Clamp
16. Clamp
17. Tube
18. Clamp
19. Mechanism assembly
20. Screw
21. Flange seal
22. Nut
23. Closet bolt
24. Cover assembly

MECHANISM PARTS DIAGRAM

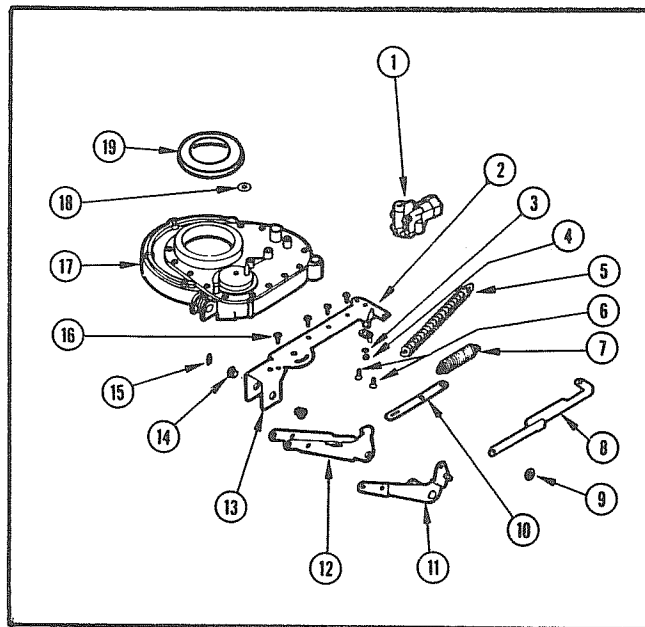

1. Ball valve assembly
2. Drive arm assembly
3. Lock washer
4. Nut
5. Spring
6. Screw
7. Spring
8. Drive arm
9. Retaining ring
10. Push link
11. Pedal arm assembly
12. Pedal arm
13. Lever plate assembly
14. Bushing
15. External cotter
16. Screw
17. Base and cover assembly
18. Retainer
19. Seal

ELECTRICAL SYSTEM

City Power (110 Volt)

The electrical system of your Land Yacht is centered at the converter. This means the 12 volt fuses and 110 volt breakers are readily accessible in all models. In 29 and 32 foot units the access panel is located under the refrigerator, while in the 33 foot model it is under the lounge.

The main supply of power to the converter comes from the power cord when plugged into 110 volt city power. The power cord is located in a lower exterior compartment, behind the wheel well on the roadside of the trailer. When the exterior door is lowered the cord can be seen coiled on a slide-out tray. Slide the tray out until the stops are reached, then let the tray swing down.

WARNING: When the three pronged plug can be used there will be no problems with proper polarity or grounding. In some older parks and other locations where three pronged outlets are not available, certain precautions to insure proper grounding and polarity must be taken. These precautions are listed below:

1. Attach the three pronged plug to a two pronged adapter. The third conductor line of this adapter has a short wire lead which must be grounded.
2. For proper grounding connect the short ground lead to a grounded outlet box or to a cold water pipe. When no water pipe is available drive a metal rod two feet into the ground and attach the ground lug to it, thus providing the unit with proper grounding.

Avoid using adapters whenever possible. The poor or lack of grounding is not safe, plus they will generally not carry voltage as well as the large plug. The low voltage can prohibit the use of the air conditioner and may affect other appliances as well.

Once the 110 volt current reaches the converter it is split into three circuits and distributed throughout the trailer to convenience outlets and appliances. For your safety the circuit in the bathroom and to the exterior outlet is protected by a Ground Fault Interrupter (GFI) breaker.

The GFI breaker is extremely sensitive to irregularities to ground, and in theory will "kick out" before a person can be dangerously shocked. Think of the GFI breaker as you would a fire extinguisher. Do you really want to expose your family to electrical shock or fire to see if they work?

A chart to record testing and test instructions for the GFI breaker is located on the inside of the converter door.

If one of the 110 volt breakers trips it is reset by turning off, then back on again. If it trips a second time reduce the load on the circuit prior to turning on again. If the breaker still strips after reducing the load it indicates a short circuit and should not be used until corrected by a qualified electrician.

A Land Yacht equipped with an optional MICROWAVE OVEN will have a priority switch mounted in the end of the closeout behind the range exhaust hood. The priority switch will allow current to either the microwave or the roof air conditioner, but only one at a time determined by the position of the switch. Both of these appliances require a large amount of current, and attempting to operate both at the same time will only overload the circuit breakers of the trailer, or the breakers or fuses where you have plugged in the power cord.

TYPICAL 110 VOLT VAC LAYOUT - FRONT LOUNGE

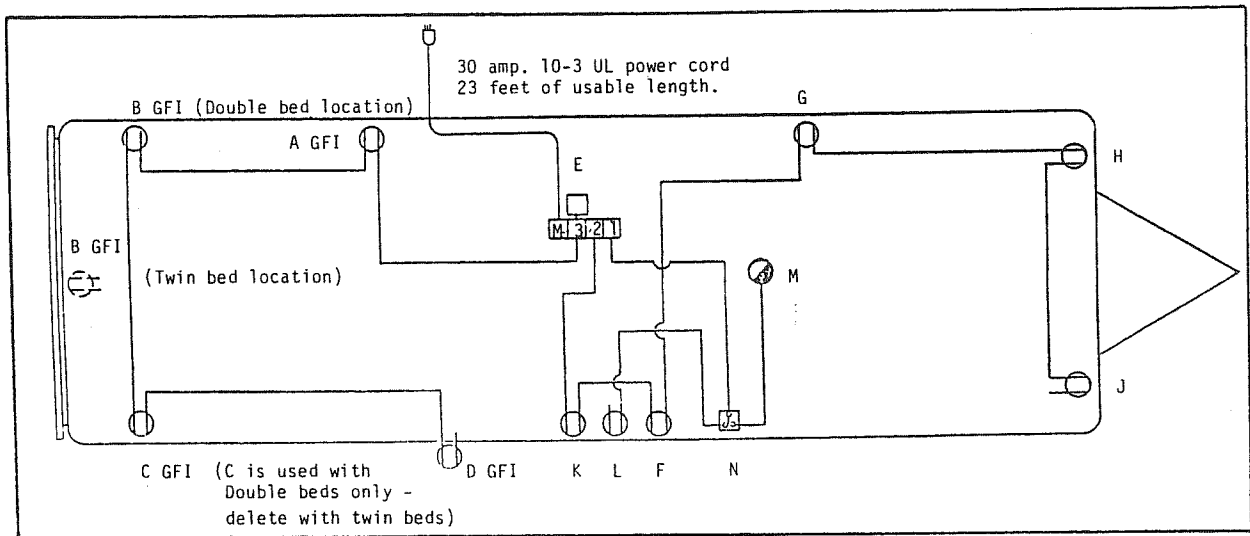

Circuit 3, 15 amp Breaker, 14-2 Romex w/Ground, GFI Protected.

- A. Bath receptacle
- B. Roadside bedroom receptacle
- C. Curbside bedroom receptacle (double bed)
- D. Outside receptacle
- E. Converter

Circuit 2, 20 amp Breaker, 12-2 Romex w/Ground.

- F. Kitchen receptacle
- G. Dining Area receptacle
- H. Roadside living area receptacle
- J. Curbside living area receptacle
- K. Refrigerator receptacle

Circuit 1, 20 amp Breaker (HACR as required by the air conditioner manufacturer's date plate) 12-2 Romex w/Ground.

- L. Microwave oven
- M. Air conditioner
- N. Single pole, double throw, 20 amp rated UL/CSA switch. This switch is used to supply the power to either the microwave oven or the air conditioner, but not at the same time.

TYPICAL 110 VOLT VAC LAYOUT - FRONT KITCHEN

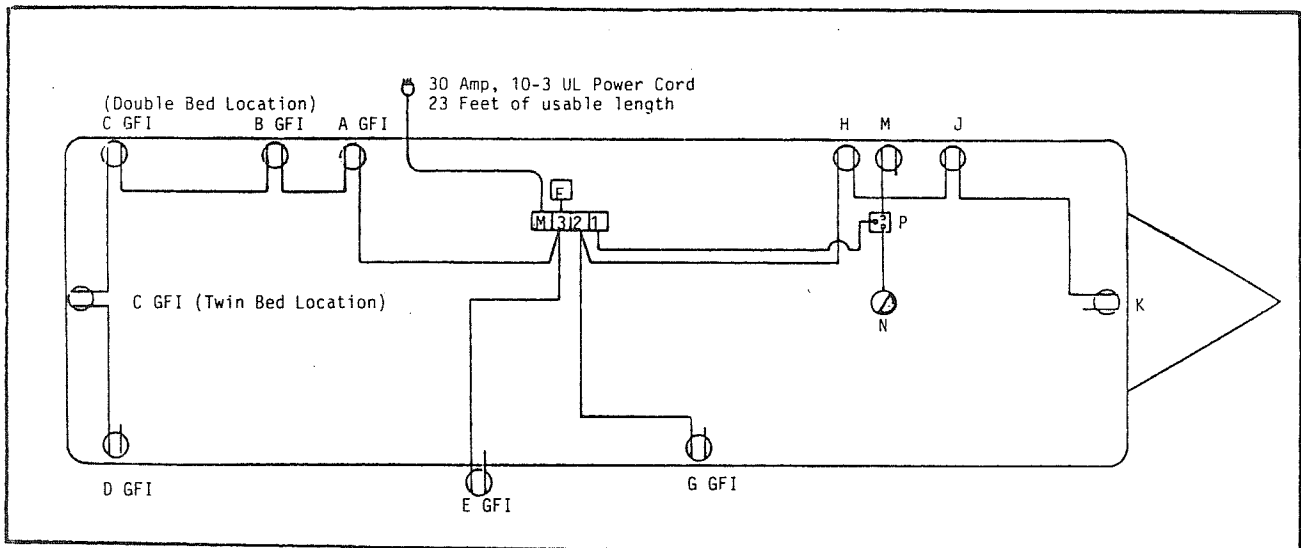

Circuit 3, 15 Amp Breaker, 14-2 Romex w/Ground, GFI Protected

- A. Bath receptacle
- B. Roadside Bedroom Receptacle
- C. Roadside Bedroom Receptacle
- D. Curbside Bedroom Receptacle
- E. Outside Receptacle
- F. Converter

Circuit 2, 20 Amp Breaker, 12-2 Romex w/Ground

- G. Curbside Table Receptacle
- H. Refrigerator Receptacle
- J. Kitchen Receptacle
- K. Front Kitchen area Receptacle

Circuit 1, 20 Amp Breaker, 12-2 Romex w/Ground. Breaker is an HACR type as required by the air conditioner manufacturer's date plate.

- M. Microwave Oven
- N. Air Conditioner
- P. Single pole, double throw, 20 Amp rated, UL/CSA switch. This switch is used to supply the power to either the microwave oven or the air conditioner, but not both at the same time.

110 VOLT DISTRIBUTION PANELBOARD

Manufacturer: B-W Manufacturers, Inc.
721 North Webster Street
P.O. Box 739
Kokomo, Indiana 46901
Phone: 317-452-5444

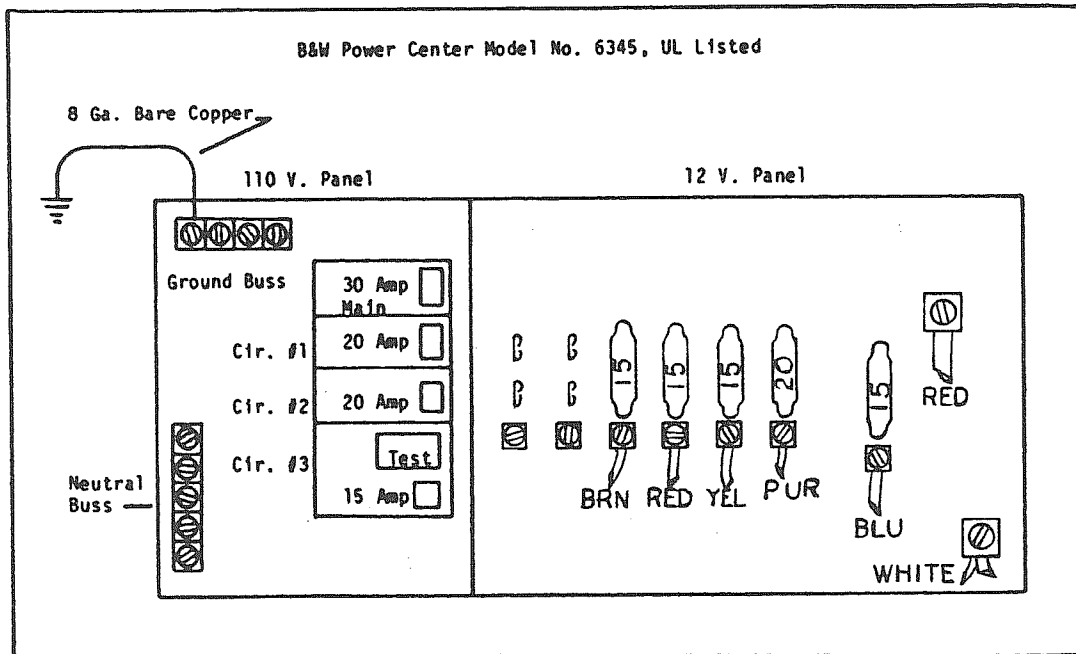

Circuit 1, 20 Amp Breaker (HACR as required by the air conditioner manufacturer), 12-2 Romex with Ground. Circuit 1 powers the air conditioner or microwave oven. These appliances are switched by means of a single pole, double throw, 20 amp rated UL/CSA switch.

Circuit 2, 20 Amp Breaker. 12-2 Romex with ground. This circuit powers the galley, refrigerator, dining area and living area receptacles.

Circuit 3, 15 Amp GFI Breaker, 14-2 Romex with ground. This circuit powers the bedroom area receptacles and bath receptacles, outside receptacle and the converter section of the power center.

B&W Power Center. Electrical Rating: Input: 6.8 amps, 120 VAC, 60 Hz.
Output: 45 amps, 12 VDC (includes 3 amp charging rate) Class CTL
Panelboard. Electrical rating: Max. Main 30 amps. 120 VAC.

INTERNAL WIRING - B-W CONVERTER

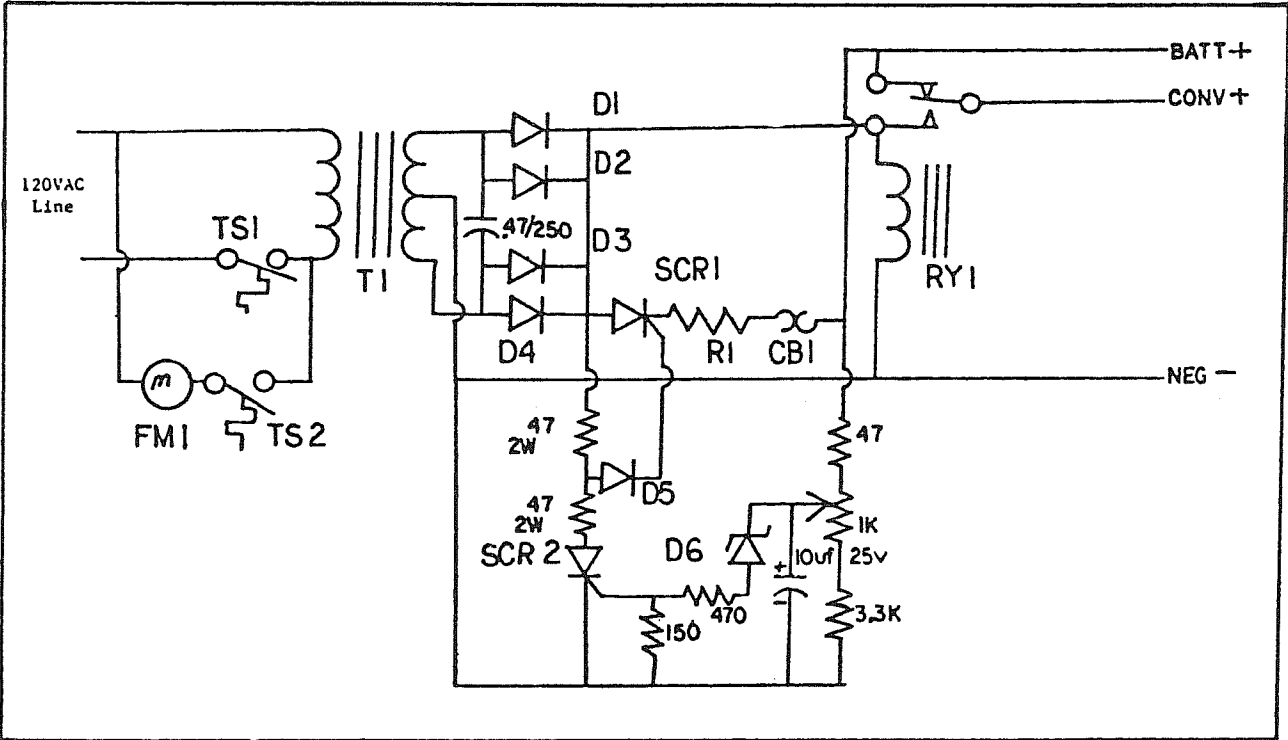

12 VOLT SYSTEM PLUGGED INTO CITY POWER

Once the trailer is plugged into city power and 110 volts is available to the converter, lights and 12 volt appliances may be operated without running down your battery(ies).

The converter has changed (or converted) the 110 volt alternating current into approximately 13.8 volts of direct current. The converter is rated for a 45 amp supply on the 12 volt side. If more than a 45 amp load (figure about 1.4 amps draw per bulb) is put on the system most of the power will still be coming from the converter with the batteries making up the rest of the requirement. In this situation the batteries will be slowly discharging. This high amperage load described is rarely seen in normal use of the trailer, and then for relatively short times.

Circuit #5 (blue wire) on the converter is wired in directly with the batteries and is considered a filter circuit used for the entertainment center and both 12 volt receptacles. The batteries act as filters and keeps the circuit as static free as possible. If the batteries are discharged, the amperage draw on this circuit should be kept to a minimum in order to obtain the fastest charging rate to the battery. As the voltage in the battery rises the charging rate is reduced automatically by the circuitry in the converter.

The converter has a small fan that is thermostatically controlled. Since operation of the fan has a direct relation to the amperage draw on the converter, it may continue to run for a period of time after the load has been reduced or eliminated.

The 12 volt fuses in the converter may be purchased from your dealer, many service stations or most automotive parts outlets. Occasionally a fuse may "blow" for no apparent reason, be replaced with a new fuse, and never cause a problem. If the replacement fuse blows there is an overload or a short on that circuit. Refer to the 12 volt wiring diagram and turn the lights and fans off on the problem circuit before trying another fuse.

WARNING: Never replace a fuse with one having a higher amperage rating. Wires can become overheated and start fires.

The appearance of the blown fuse can give a clue to the problem and should be saved in case repairs are needed and the electrician would want to examine the fuses.

A fuse blown from a slight overload, or because it was weak, will have an element with a melted look and a small gap. In general the higher the overload the wider the gap.

A fuse blown from a short circuit will have a wide gap in the element and the inside of the glass tube will be smudged with smoke.

On rare occasions a defective fuse can really fool you. The element in the center of the glass will be intact, but has come loose from the metal end cap, breaking the circuit. The fuse will appear to be good, but can be detected by testing with an inexpensive 12 volt test light.

The entertainment center has an additional 3 amp in-line fuse located in the cabinet.

12 VOLT SYSTEM - BATTERY ONLY

When you are not plugged into city power your lights, fans and 12 volt appliances such as the furnace and water pump work in the same manner as when you are plugged into 110 volt city power. However, in this mode all the power is being supplied by the batteries, so they are discharging.

In warm weather it isn't too difficult to stretch your battery for five days or more with a little practice. During warm weather the days are normally longer, not as much time is spent indoors and the furnace isn't running. All of these contribute to a long lasting battery.

In cooler weather, if your stay is going to last longer than a couple of days, you should make every effort to plug into 110 volt city power. If city power is not available connecting the car and trailer and letting the car run at fast idle for about one half hour will usually pretty well recharge your battery. It is much easier on the battery if you charge it for a short time each day rather than let the battery run down then try to charge it for a longer time. A battery that has been totally discharged will never regain its original capacity.

The battery is accessible through an external access door.

In the area of the battery is two heavy duty 12 volt automatic circuit breakers. The 40 amp breaker protects the charge line and the 50 amp breaker protects the heavy feed wires between the battery and the 12 volt distribution panel. If either wire should ever become short circuited you will be able to hear a "click" and the lights will dim or go out completely. If it is an overload condition, turning out lights or shutting off appliances will correct the situation.

CAUTION: Disconnect the battery if the breaker continues to kick on and off to prevent damage to the electrical system.

WARNING: The gases generated within a storage battery cell may be ignited by an open flame or spark in the vicinity of the battery. DO NOT USE A MATCH OR FLAME TO PROVIDE LIGHT FOR CHECKING THE LEVEL OF THE WATER.

During the winter the battery should be removed from the trailer and stored in a cool, dry place where there is no danger of freezing. It should be kept full of water, cleaned and charged monthly. A battery which is allowed to completely lose its charge will never regain its original power, or a full charge.

For battery service or replacement go to any service station or dealer who sells and services the make battery installed in your trailer.

ELECTRICAL TROUBLE SHOOTING

SYMPTOM: No 12 volt power (lights, appliances do not work).

POSSIBLE CAUSE:	REMEDY:
1. Input line and/or battery not connected.	1. Make necessary connections.
2. Discharged trailer battery.	2. Charge Battery.
3. Trailer battery on wrong polarity.	3. See Item 7.

SYMPTOM: Fuse blowing

POSSIBLE CAUSE:	REMEDY:
4. Overloaded circuit (over 45 amps)	4. Turn off switches to reduce load.
5. Electrical short	5. Check the circuit for defective wiring, lamps or motors.
6. Shorted battery	6. Replace battery
7. Battery terminals not properly connected to converter + and - terminals.	7. Make proper connections.

SYMPTOM: Dim lights or sluggish fan motor.

POSSIBLE CAUSE:	REMEDY:
8. 25- or 50- cycle power (some foreign countries).	8. Use 60- cycle power.
9. Discharged battery (when operating without 120V line)	9. Charge battery.
10. Battery is low on water.	10. Add distilled water to battery.

Electrical Trouble Shooting Continued...

SYMPTOM: Converter will not charge battery.

POSSIBLE CAUSE:

REMEDY:

- | | |
|--|---|
| 11. Input line not connected. | 11. Connect input line. |
| 12. Battery not connected (or polarity reversed) | 12. Connect battery to CONVERTER (Check polarity) |
| 13. Bad Battery | 13. Replace Battery |
| 14. Too many lights and appliances. | 14. Reduce electrical load on blue circuit (12 volt receptacle, entertainment center) |

WIRE ROUTING - 12 VOLT DISTRIBUTION PANEL TO LIGHTS OR APPLIANCES

(SCHEMATICS ON FOLLOWING PAGES)

The 12 volt Distribution Panel is part of the converter. When the access door of the converter is opened the 110 volt circuit breakers are on the left, and the low voltage fuses are on the right.

The 12 volt wires go into the wall, then straight up to the center of the roof. The center of the roof is the major path of all the wires. From here the wires run as shown on the schematics on the following pages.

The white ground wires running to each light or appliance are not shown. If ground current is lost in any white wire simply reground to the nearest metal structure.

The wires are all color coded, and are sized to more than adequately carry the required loads. When connections are made plenty of slack is left in the wire so it can easily be worked on without splicing.

WIRE ROUTING SCHEMATIC - 27 FOOT MODEL

12 VOLT DISTRIBUTION PANEL TO LIGHTS OR APPLIANCES

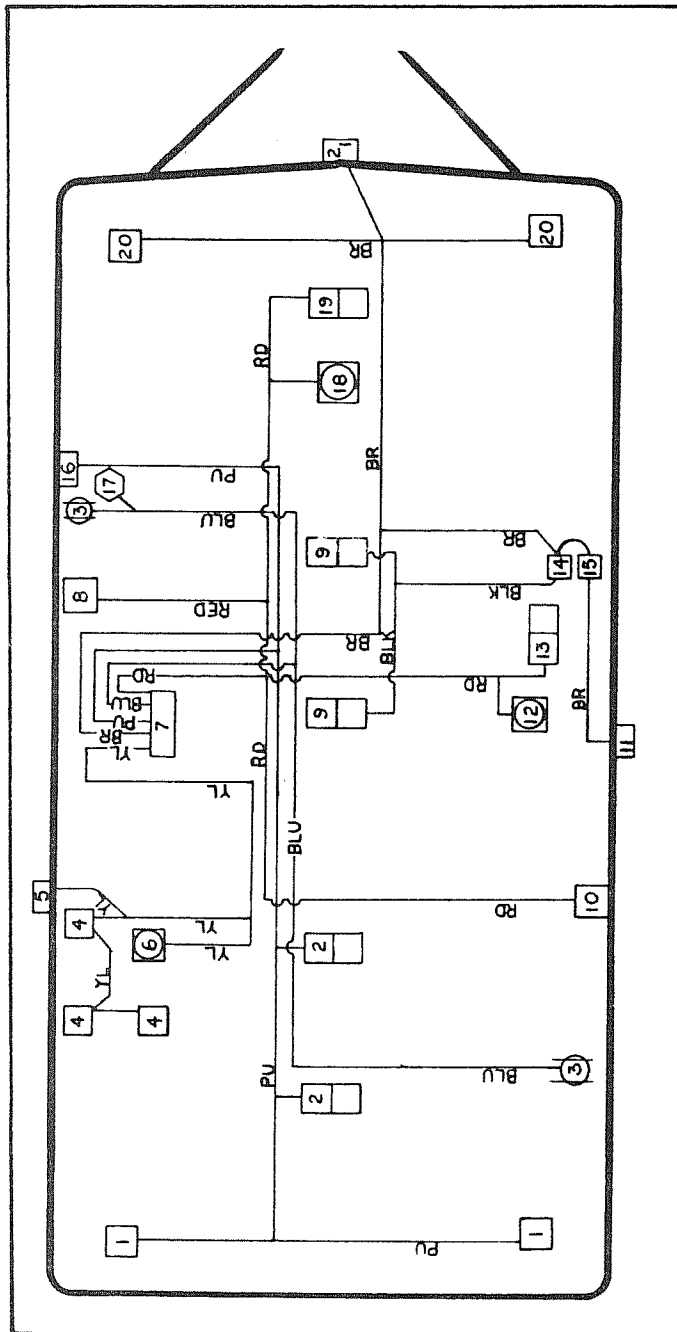

- | | |
|------------------------------------|--------------------------------|
| 1. Reading lights, rear | 12. Range exhaust |
| 2. Ceiling lights, rear | 13. Galley light |
| 3. 12 Volt outlet | 14. Switch, ceiling lights |
| 4. Bath lights | 15. Switch, patio light |
| 5. Exterior convenience light | 16. Monitor panel |
| 6. Bath exhaust fan | 17. Radio, stereo |
| 7. 12 Volt fuse panel | 18. Ceiling vent |
| 8. Refrigerator | 19. Front Ceiling light |
| 9. Ceiling Lights, remote switched | 20. Reading lights, front |
| 10. Furnace | 21. Exterior convenience light |
| 11. Patio Lights | |

WIRE ROUTING SCHEMATIC - 29 & 32 FOOT MODELS

12 VOLT DISTRIBUTION PANEL TO LIGHTS OR APPLIANCES

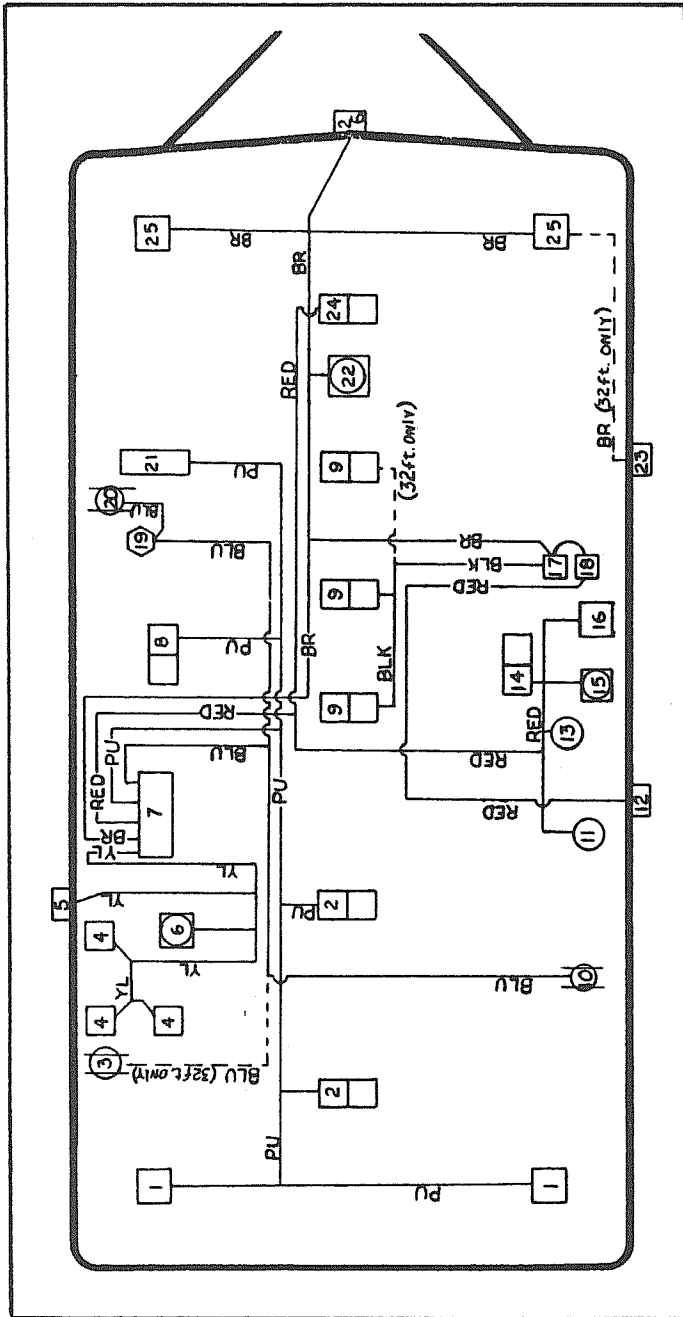

- | | |
|------------------------------------|----------------------------------|
| 1. Reading lights, rear | 14. Galley light |
| 2. Ceiling lights, rear | 15. Range exhaust |
| 3. 12 Volt outlet, 32 ft. only | 16. Furnace |
| 4. Bath lights | 17. Switch, patio light |
| 5. Exterior convenience light | 18. Switch, ceiling lights |
| 6. Exhaust vent bath | 19. Entertainment center |
| 7. 12 Volt distribution panel | 20. 12 Volt outlet |
| 8. Dinette light | 21. Monitor panel |
| 9. Ceiling lights, remote switched | 22. Ceiling vent |
| 10. 12 Volt outlet, 29 ft. only | 23. Light, grab bar, 32 ft. only |
| 11. Refrigerator light | 24. Ceiling light, front |
| 12. Patio light | 25. Reading lights, front |
| 13. Oven light | 26. Exterior convenience lights |

WIRE ROUTING SCHEMATIC - 33 FOOT FRONT KITCHEN

12 VOLT DISTRIBUTION PANEL TO LIGHTS OR APPLIANCES

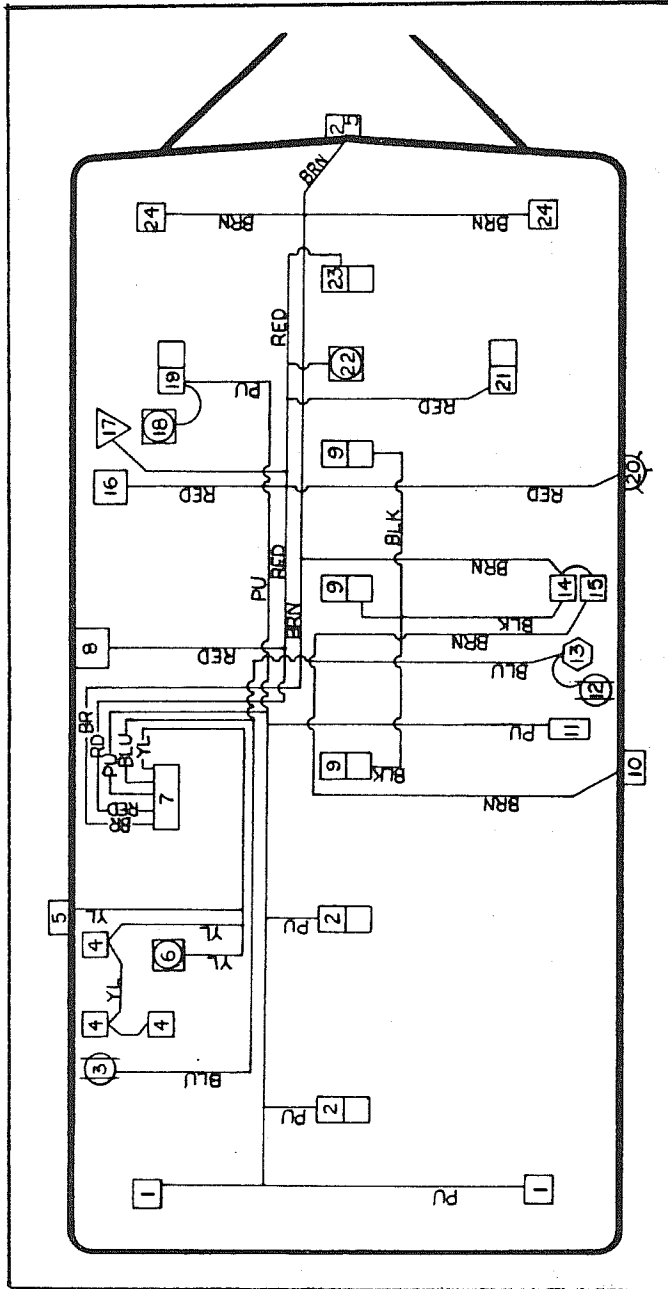

- | | |
|------------------------------------|---------------------------------|
| 1. Reading lights, rear | 14. Switch, ceiling lights |
| 2. Ceiling lights, rear | 15. Switch, Patio light |
| 3. 12 Volt jack | 16. Refrigerator |
| 4. Bath lights | 17. Oven light |
| 5. Exterior convenience light | 18. Range Exhaust hood |
| 6. Exhaust vent, bath | 19. Galley Light |
| 7. 12 Volt distribution panel | 20. Exterior light, grab handle |
| 8. Furnace | 21. Dinette Light |
| 9. Ceiling light - remote switched | 22. Vent, ceiling |
| 10. Exterior, patio light | 23. Ceiling light, front |
| 11. Monitor panel | 24. Reading lights, front |
| 12. 12 Volt jack | 25. Exterior Convenience Light |
| 13. Radio/stereo | |

WIRE ROUTING - 7-WAY PLUG TO BATTERIES AND 12 VOLT DISTRIBUTION PANEL

(SCHEMATIC ON FOLLOWING PAGE)

The 7-way cable runs back through the "A" frame and ends at the lower roadside front corner of the trailer. An access panel has been provided so the circuit breaker and wire connections at this junction can be checked.

From this point the taillight wires run straight up the wall to the corner radius of the roof. The wires follow the corner radius of the roof to the end of the side wall, then drop straight down to the roadside taillight, then across to the curbside.

NOTE: Of special interest is the green clearance light wire running across the roof of the trailer to the center side marker light. This wire is run through a 3/4" plastic tube. The ends of the tube are accessible (from the interior) in the radius corner of the roof just forward of the bath wall on the roadside and just forward of the refrigerator on the curbside. If a new wire of any kind must be run from side to side it can easily be "fished" through the tube.

WIRE ROUTING SCHEMATIC - 7-WAY PLUG TO BATTERIES AND 12 VOLT DISTRIBUTION PANEL

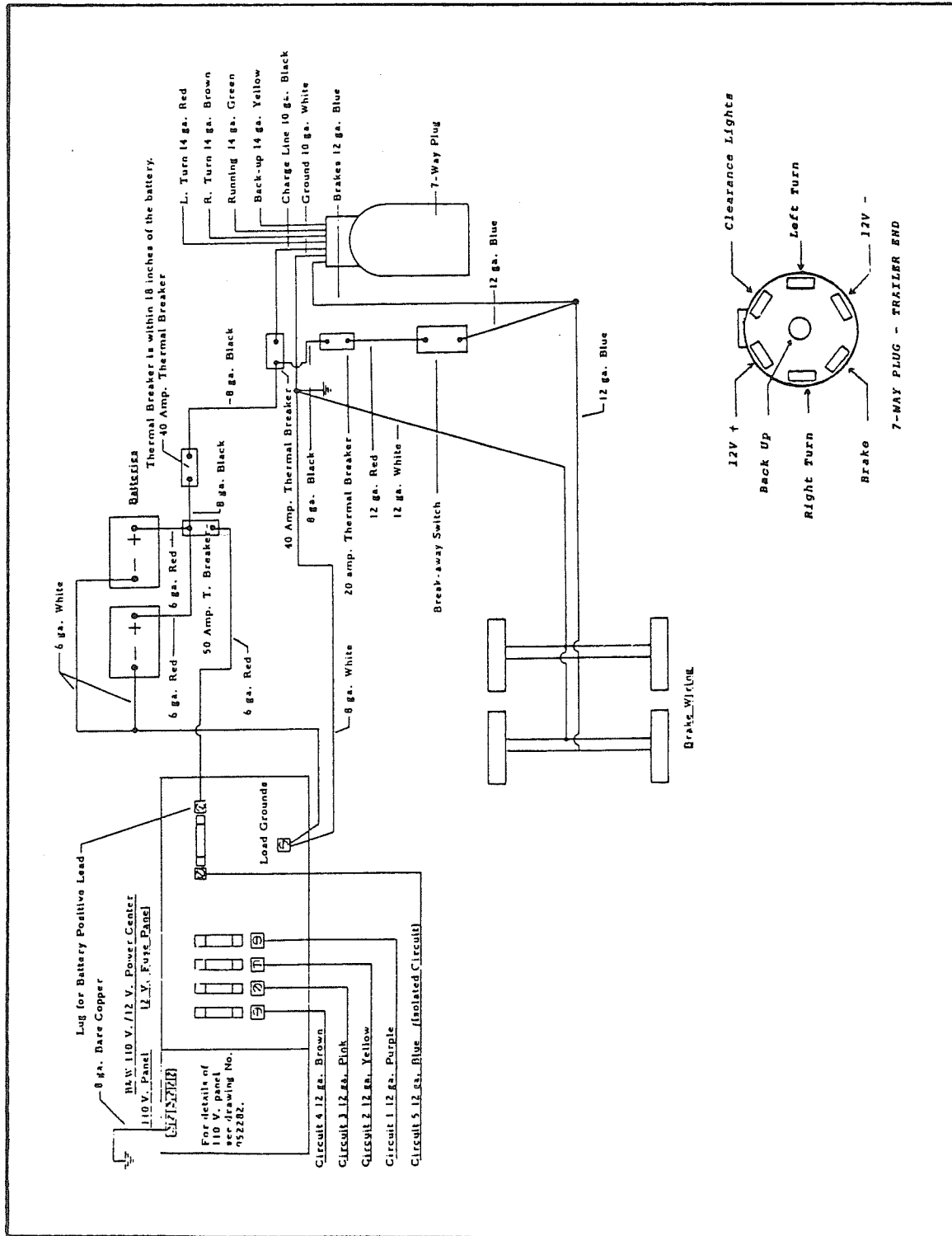

12 VOLT BULB REPLACEMENT

EXTERIOR

CLEARANCE LIGHTS: Insert a screwdriver or thin coin between the lens and base, then twist. The lens will "pop" off. The bulbs are removed by pulling them straight out of the base.

TAILLIGHT: Remove two screws holding the lens to the base. The lens fits down in a groove and a small screwdriver or knife blade may be used to gently pry it free. The bulbs are removed by depressing, then turning one quarter turn to the left.

SIDE CLEARANCE LIGHTS: Remove screws going through lens. This allows complete light to be pulled out. Turn the rubber light socket to the left one quarter turn and it will pull out of the base exposing the bulb. Pull the bulb straight out of the socket.

CONVENIENCE LIGHTS: (Located on side above plumbing connection and on the front above LP bottles.) Push up on bottom of lens then pull out. Once the bottom of the lens is clear of the base let the complete lens fall free. The bulb is removed by depressing and turning to the left one quarter turn.

LICENSE PLATE LIGHT: Remove screws attaching light assembly to body. Depress base of clear lens and it will slide out of light assembly. Depress bulb and turn one quarter to left to remove.

STEP LIGHT: (In assist handle) Use small (#1) Phillips screwdriver to remove two screws holding lens. Depress bulb and turn to left to remove.

INTERIOR 12 VOLT LIGHTS

ALL: Squeeze side of lens and pull down. To remove bulb depress into base and turn to the left one quarter turn.

TV ANTENNA

Manufacturer: Braund Manufacturing Company
730 East Michigan Avenue
Battle Creek, Michigan 49016
Phone: 616-965-2371

The controls for the TV antenna are in the ceiling directly below the antenna. To raise the antenna, turn hand crank clockwise until it stops. Then turn on TV set and select channel. While watching picture, reverse the handle approximately one half turn, push handle up toward the ceiling, hold in that position and rotate antenna. If you hit a stop in rotation before the picture is clear, reverse rotation. You may have to readjust when changing channels. To close, reverse the direction of cranking. Before traveling, check outside that the antenna is folded and pointed straight forward.

About twice a year each pivot point on the antenna should be lubricated with an aerosol such as WD-40.

TROUBLE SHOOTING

DIFFICULT TO PUSH HANDLE UP AND DOWN

- A. After raising the antenna always "back off" the crank handle in the opposite direction about half a turn before pushing up to the rotate position.
- B. It is very important that there is no sideways pressure on the shaft when the ceiling plate is fitted. To check this, raise antenna, remove the ceiling plate and refit crank handle. The shaft should move up and down with little effort. Before refitting ceiling plate, enlarge the ceiling hole so that the plate will fit flush to the ceiling without putting any stress on the shaft.
- C. The shaft may have been cut too short during installation, thus preventing up and down movement. The only remedy is to replace the shaft. Remove pin (80405) which passes through the slot in top of worm (10300). Shaft (12927) may then be withdrawn downward after removing the ceiling plate (10302). The new shaft should be checked for "burrs" and coated with silicone grease before fitting. Use a twisting motion when inserting the new shaft to avoid damage to the "O" ring (80903) positioned just below the worm (10300).

DIFFICULT TO ROTATE

- A. The most common cause is excessive caulking around the base and mounting plate causing binding. In extreme cases it will be impossible to turn the antenna, usually resulting in breakage of the crank handle (10739). Check that the bearing surfaces of the base (12928) and mounting plate (12660) are clear of caulking or sealing material.
- B. If the lead wire (10319) is too short (less than 4 feet) it may prevent full rotation, or if too long the loop may catch on some other roof top device such as a vent.
- C. The antenna may have been installed too close to a vent or air conditioner with insufficient clearance for the base to rotate fully.

ANTENNA WILL NOT RAISE

- A. Usually caused by a stripped worm gear (10294) and/or worm (10300). Gears are usually damaged by (1) trying to raise the antenna by turning the crank in the wrong direction. (2) With the antenna raised a heavy blow on the antenna head from a tree limb will strip either or both gears. For this reason we do advise against driving with the antenna in the raised position. A new worm gear (10294) is easily replaced after removing the gear cover (12662) and withdrawing the drive axle (12394). The worm (10300) may be replaced by removing pin (80405) at top of worm and then partly withdrawing the shaft (12927) downwards until it is clear of the worm. Damaged worm may then be removed and replaced. **CAUTION:** Do not lose the worm washer (80233) which is positioned just below the worm.

All of the above work may be carried out without removing the unit from the vehicle. However, any damage to the base (12928) or plate (12660) will require removal from the roof.

RECEPTION

Due to the various locations used by recreational vehicles, reception will not be so consistent as at a fixed location because of the large variation in the terrain encountered throughout the country. In general TV/FM signals (particularly UHF) travel roughly in a straight line so hills or mountains etc. between your vehicle and the transmitting station may severely reduce the amount of signal reaching your antenna.

When more than one TV outlet jack is used in a vehicle it is ESSENTIAL to use a splitter device (this is incorporated in the Braund PBA booster amplifiers or Autocouplers) to avoid reduction in picture strength and quality.

TV ANTENNA

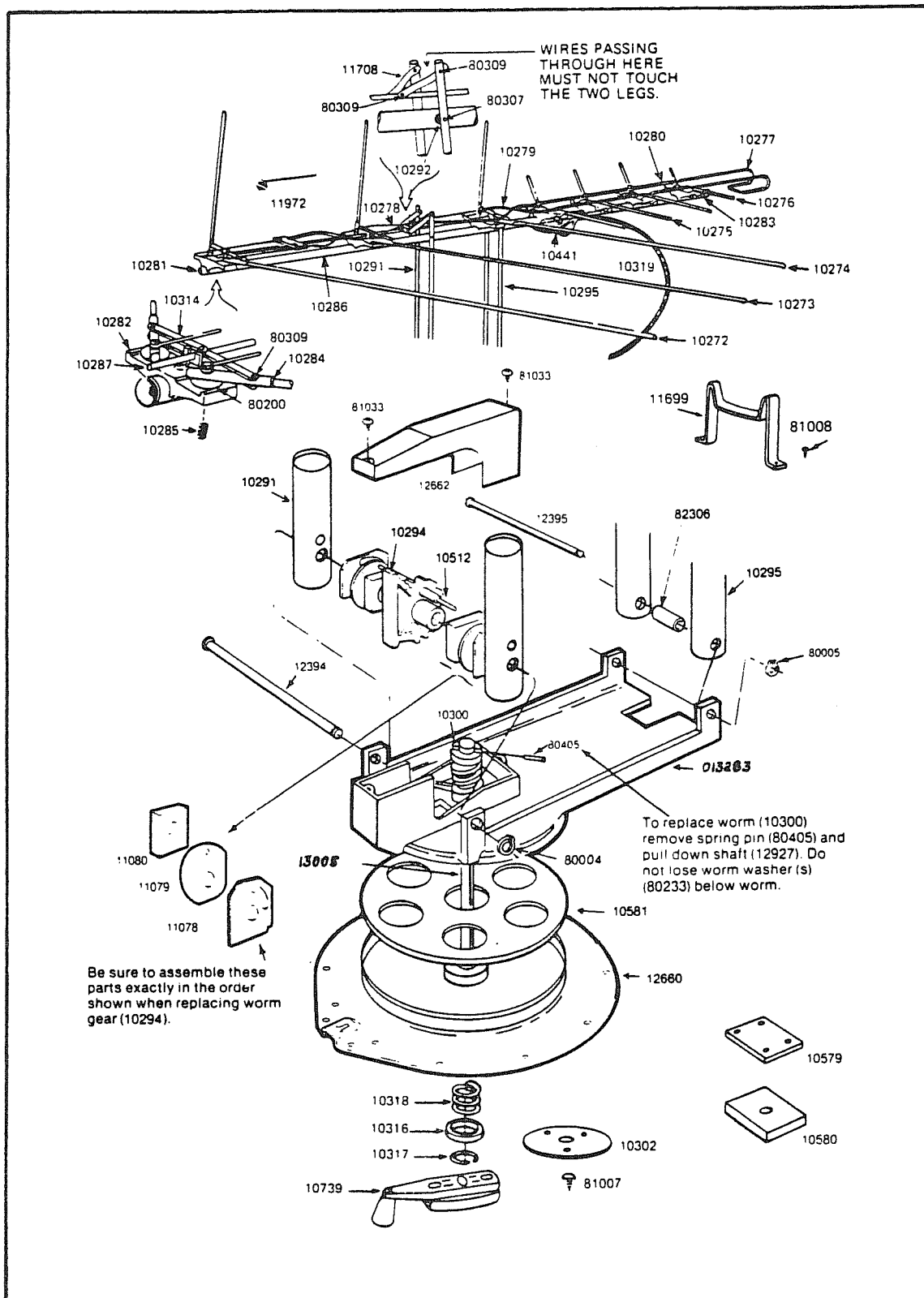

MONITOR PANEL

Manufacturer: Larson Electronics Mfg.
216 E. Imperial Hwy, Suite, 550
Fullerton, CA 92635
Phone: 714-738-3551

The solid state central control panel has two different configurations. The Deluxe panels include two LP tank gauges and auto water tank fill controls. The water and holding tanks and battery check is common to both panels. Also common are the water pump switch, range hood light, range hood fan, and power on light.

To check the tank capacities depress the button for the tank you wish to check and read the status by the LEDs directly above the switches. The power on light will automatically glow whenever you are connected to 120 volt power.

Battery Condition Tester

The battery condition tester, used when not plugged into 110 volt power, will indicate whether the trailer batteries are in good, fair or poor condition. When they show weak or bad condition you should take every reasonable step to conserve power by using as few lights as possible and switching off appliances. The battery should be charged as soon as practical with the tow vehicle charging system, or by connection to 110 volt power.

Water Pump Switch

The water pump switch operates the pump. Once the switch is turned on the pump will run until the water pressure reaches about 35 psi. At this point an internal pressure switch will shut it off. When a faucet is opened the water pressure will drop and the pump will start to run again. The water pump switch should be turned off when you are on city water or when the trailer is left unattended.

LP Gauge Switch

The LP gauge switch reads the status of the LP tanks by movement of the rocker switch. Moving the switch in the upward direction will read the roadside bottle. Downward movement of the switch reads the curbside. The contents of the tanks is indicated by the LED read out above the holding tank and battery condition buttons.

Automatic Water Fill Switch (Optional on some models)

The water tank fill switch controls a solenoid. The solenoid is normally closed. By depressing the water tank fill switch voltage is applied to the solenoid, opening it and allowing water to fill the fresh water tank. The valve is designed so that it automatically shuts off when the tank reaches three quarter full. Do not expect it to fill your tank to the "brim". Try to remember to shut your switch off after filling.

SERVICE INFORMATION

The monitor panel is held in the cabinet by screws in the face of the monitor panel. Remove these screws and pull the panel straight forward.

To operate, push the buttons for the desired system you wish to check and read the condition on the LEDs above the switch.

CALIBRATION

To calibrate your monitoring panel, simply fill all of your tanks with tap water. Set the selector switch to the tank to be calibrated. Press the test switch and, using a small flat bladed screwdriver rotate the adjustment located behind the small hole on the face of the panel and identified by the small black letter above (F fresh, G grey, B black). As the adjustment is turned the lights will turn on and off in sequence. When the last light (marked F) is fully lit, the tank is properly calibrated.

PRINCIPLES OF OPERATION

Two aluminum foil pads are glued to each tank. A small high frequency alternating voltage is passed to one of the pads. A radio signal is capacitively coupled to the other pad. The radio signal is passed back up to the panel where it is electronically converted to a direct voltage which drives the LED readout.

That is the mechanism by which the water level is sensed through the walls of the tank. The radio signal (and the readout) is proportional to the area of the aluminum foil pads covered by water (on the other side of the tank wall). Therefore, if the pads are installed correctly the readout is proportional to the water level in the tank.

TROUBLE SHOOTING CONSIDERATIONS

For the purposes of trouble shooting we usually divide the system into three components:

1. The panel.
2. The cable harness (and panel connection).
3. The tanks (and foil and tank connections).

Generally the first step is to see if the problem is caused by improper adjustment. If not, check to see if the panel is defective. If it is not, check either the tanks or the cable harness (or both) in whichever order is most convenient.

SYSTEM CONFIGURATION

The cable harness is connected to the tanks and the panel (and the power and LPG) as shown below:

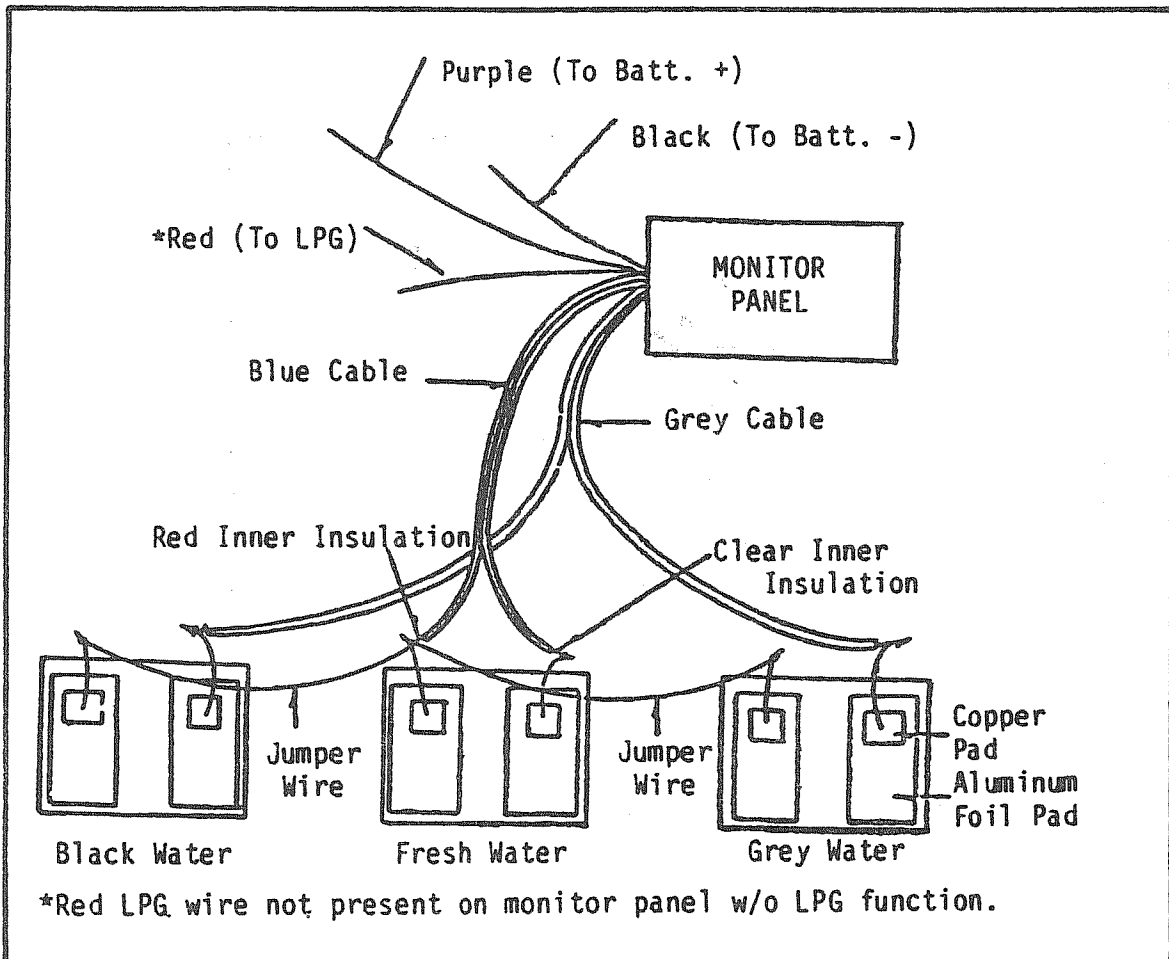

The alternating voltage is passed down to one of the aluminum foil pads on the fresh water tank by the blue cable, red inner insulation side. (See Cable Construction for details and terminology.) The alternating voltage is passed from that connection to one of the pads on each of the holding tanks by two jumper wires.

The radio signal is passed from the other pad on the fresh water tank to the panel by the blue cable, clear inner insulation side. The radio signal is passed from the holding tanks to the panel by the two sides of the grey cable.

CABLE CONSTRUCTION

Each cable consists of two sides bonded together in a zip-cord. Each side has a copper stranded center conductor covered by an insulating layer (inner insulation is red on one side and clear on the other side). A non-insulated copper stranded wire runs alongside (called the "drain wire") and an aluminized mylar foil (called the "shield") is spiral wrapped around the center conductor and the drain wire both. A PVC jacket which is either blue or grey covers the whole cable. See below:

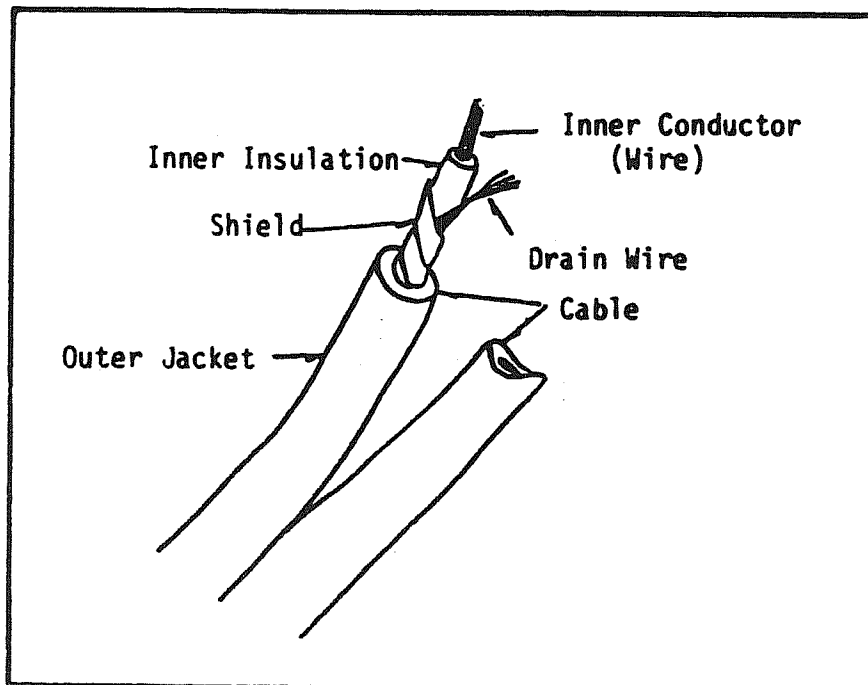

The center conductors conduct the alternating voltages and radio signal. The center conductors are connected to a wire soldered to a copper foil pad which is glued to the aluminum foil pad. This method is used because of the difficulty of soldering copper to aluminum. The drain wires and the shields (since they touch the drain wires) are grounded to the frame through the panel.

The aluminum pads are glued to the tanks with a rubber based glue. This is because polyethylene (the tank material) expands more than the aluminum pads when heated. Using the glue allows the pads and tank to expand at their differing rates without breaking the glue joint.

PROBLEM SOLVING

PROBLEM: No LEDS go on when the test switch is pressed.

CAUSES: A. Panel is getting no power.

B. Defective panel.

- REMEDY:
1. Test panel on module tester or replace panel to see if the same problem occurs.
 2. Check to see if the connector is on properly. Connector pins must contact the foil etch fingers on the board (if edge connector is used).
 3. Using a voltmeter, check to see if the power wires at the connector have about +12 volts across them (purple is positive, black is negative).
 4. Make sure power wires are not reversed.

PROBLEM: Panel reads only empty on one or more tanks.

CAUSES: A. Broken connections to tanks.

B. Aluminum foil pads loose.

C. Not enough aluminum foil pad area.

D. Grounded center conductor of cable or pad on tank.

E. Defective panel.

- REMEDY:
1. Fill tanks and adjust pots completely clockwise. If you do not want to fill the tanks you can simulate a full tank by pressing a hand on both aluminum foil pads on the tank.

2. Test panel on module tester or replace panel to see if the same problem occurs.
3. Visually check pads on tanks: They should be firmly stuck to the tank. They should have an area of at least 50 square inches each, and there should be no metal (other than copper foil pads) touching them (thereby grounding them).
4. Check the connections of the cables (and jumper wires) to the tank. The drain wires and shields should not be connected or touching anything. (Ideally the drain wires and shield should be trimmed back all the way to the outer jacket and a piece of electrician's tape wrapped around there).
5. If the problem still exists, disconnect all of the tank connections from the tanks, but keep the blue cable, red side and the two jumper wires connected together. Apply the "finger test" to each set of cable pairs (or cable-jumper wire pairs on the holding tanks).

FINGER TEST: Lick your thumb and fore-finger of one hand. Lay the bare ends of the cable pair (or the cable-jumper wire pair) which were connected to a tank on your fore-finger, close to each other but not touching. Squeeze the two ends between your thumb and finger. This simulates a full tank, so the panel should read full on whichever tank the cable pair (or the cable-jumper wire pair) was connected to. You should be able to vary the reading by squeezing harder or softer.

If you cannot get a good finger test on all three tanks, or the fresh tank only, the blue cable is damaged and must be replaced. If you cannot get a good finger test on the grey and/or the sewer tank, the grey cable has been damaged and must be replaced.

If you have an Acu-Gauge cable tester, using it will shorten the trouble-shooting process. The cable tester detects shorts (to frame ground) in the cables. Use as directed in the cable tester instructions supplied with the tester. PLEASE NOTE: If a short is indicated by the tester the short could be in the indicated cable or anything connected to that cable. For example, if the blue cable-red side is indicated, that cable could be shorted, or the pad connected to that cable (on the fresh water tank) could be shorted to the frame, or the jumper wires (which are connected to the blue cable, red side) could be shorted, or the foil pads connected to the jumper wires could be shorted to the frame. The short could also be in the connection of the cable, jumper wires and foil pad.

If the grey cable (either side) is indicated, the short is either in the grey cable, the pads connected to the grey cable, or in the connections between the grey cable and its pads.

PROBLEM: Cannot get a full reading on one or more tank tests.

CAUSES: A-E Same causes as in the previous section.

F. Metal hanger strap between the two aluminum foil pads.

G. Needs slightly more foil because tank walls are thicker than usual.

H. Swelling tank loosens connection between foil strips making up pads.

- REMEDY:**
1. Do procedures 1 through 4 from the previous section.
 2. Check to see if there is a metal hanger strap passing between the pads. (The strap does not have to touch the pads to cause a problem.) If there is, remove one of the pads and relocate it so that both of the pads are on the same side of the hanger strap.
 3. If the aluminum foil pads are made of vertical strips of aluminum foil tape, run a few strips of foil tape horizontally across the vertical strips (cross-hatching). If the pads are made of horizontal strips, cross-hatch vertically.
 4. If the reading is almost full (one light down from full) try adding a little more pad area. One or two more strips on each pad should do it (assuming there were 50 square inches on each to begin with). Do not overdo this. If two more strips of aluminum foil tape per pad does not solve the problem move on to the next procedure.
 5. Do procedure 5 from the previous section.

PROBLEM: Tank tests read only full or read only where they were adjusted regardless of water level.

- CAUSES:**
- A. Power wires connected to the converter rather than the battery.
 - B. Disconnected or cut drain wires at connector.
 - C. Unshielded wire spliced into cable.
 - D. Short between center of conductors of cable, or between aluminum foil pads on tank.

- E. Pads too close together.
- F. Pads much too large.
- G. Defective panel.

- REMEDY:
1. Test panel on module tester or replace panel to see if the same problem occurs.
 2. Empty the tanks. Unplug the coach from shore power (thereby turning off the converter). If that removes the problem disconnect the power wires and reconnect them directly to the battery.
 3. Visually inspect the connector to the panel. There should be 4 bare drain wires in the connector. Drain wires should not be cut.
 4. Using an ohmmeter check for continuity between the drain wires and the frame (ground). Panel should be connected but do not push the test button. If there is no continuity and the panel is okay the connector is bad and the pin connections in the connector should be redone.
 5. Visually inspect the tanks. The aluminum foil pads should not touch each other and should be at least 2 inches apart. The aluminum foil pads should be no larger than 100 square inches (sometimes you need more than the recommended amount, 50 square inches, because the tanks are built thicker etc., but over 100 square inches is too much).
 6. Visually check to see if the proper colors of cable are connected to the tanks (blue to fresh water, grey and a jumper to each of the holding tanks). If not it is likely that some unshielded cable has been spliced on and the cable must be replaced.
 7. Expose the drain wires near the tanks by stripping back the outer jacket. Using an ohmmeter check the continuity between the drain wire and the frame (ground). Panel should be connected, but do not push the test switch. If there is no continuity the cable is damaged and must be replaced. After completing this test trim the drain wire and shield back to the outer jacket and wrap a piece of electrician's tape around there.
 8. Trace the cables to see if there are any splices. If so replace the cable.

PROBLEM: Cannot get an empty reading on tanks or LEDS flicker or some stay on.

- CAUSES:**
- A. Power wires connected to converter rather than battery.
 - B. Too much pad area.
 - C. Jumper wires too long.
 - D. Aluminum foil pads pass under the tank.
 - E. Defective panel.

- REMEDY:**
- 1. Empty the tanks.
 - 2. Test panel on module tester or replace panel to see if the same problem occurs.
 - 3. Unplug the coach from shore power. If this removes the problem disconnect both power wires and connect them as near to the battery as possible.
 - 4. Check the aluminum foil pads on the tanks. They should have an area of less than 100 square inches each. They should not touch. They should be at least 2 inches apart. They should be on the vertical faces of the tank and should not slip under the tank. Also, if the tank has a curved bottom edge the lower edge of the foil pads should be cut off just above the curved bottom edge.
 - 5. Make sure that the jumper wires are not stretched across the pads. If the jumpers are longer than 10 foot and the problem still occurs, use shielded cable for the jumper wire and connect the drain wires to the blue cable, red side drain wires (see cable construction).
 - 6. If the problem still occurs make sure the cables and jumper wires are not run alongside a wire coming from the converter.
 - 7. If the problem still occurs, do procedures 3, 4, 6, 7, and 8 from previous section.

PROBLEM: Erratic Readings: They suddenly jump two or more LEDS as you fill or empty tanks, or move when no water is being added or taken. Or, certain LEDS do not go on or go on in wrong order.

- CAUSES:**
- A. Loose intermittant connections.
 - B. Foil pad on non-vertical face of tank.
 - C. Swelling tank loosens connection between foil strips making up pad.

D. Power wire connected to converter.

E. Defective panel.

- REMEDY:
1. Test panel with module tester or replace panel to see if the same problem occurs.
 2. Check all connections for looseness, etc.
 3. Pads should be only on vertical faces and both pads should run from near the top edge of the tank to near the bottom edge of the tank. If the tank is stepped, put the pads only on the vertical faces of the tank. Connect the vertical pads across step with a thin (1/4 inch) strip of foil.
 4. If the pads are made of vertically run strips of aluminum foil tape, run a few strips of foil tape horizontally across the vertical strips (cross-hatching). If the strips making up the pads are horizontally run, cross-hatch vertically.
 5. Made sure the pads are stuck firmly to the tanks.
 6. Connect the power wires as close to the battery as possible.

PROBLEM: LPG not working (if panel is equipped with one).

- CAUSES:
- A. LPG not connected properly.
 - B. Sending unit bad.
 - C. LPG float bad.
 - D. Defective panel.

- REMEDY:
1. Test panel on module tester or replace panel to see if problem still occurs.
 2. Ground red wire from connector. LPG should read empty. Disconnect red wire. LPG should read full.
 3. Check to see that the red LPG wire in the connector to the panel is in the proper slot in the connector. On the 106 horizontal models, the proper slot is the 7th from the top. On the 106 vertical models, the proper slot is the 7th from the left. On the 105 models, the proper slot is the 11th from the left. On the HRC models the proper hole is the middle vertical row, second horizontal row from the top. (The top of the connector has 2 notches in it.)

4. Connect the red wire to the 90 ohm sending unit on the LPG tank.
5. Check to see that the sending unit and LPG tank float magnets are aligned.
6. Replace sending unit.
7. Replace tank float system.

PROBLEM: Aluminum foil pads came unstuck.

CAUSES: 3M 4693 glue was not used to stick the pads on.

110 VOLT ELECTRICAL SYSTEM

CITY POWER

The Airstream univolt system enables you to use the lights and appliances whether operating on self-contained battery power or hooked up to 110 volt city power. The 12 volt light bulbs give off the same light as regular household bulbs, so that when operating on self-contained battery power, everything works normally except the 110 volt convenience outlets and 110 volt appliances.

Exterior outlets for 110 volts are located on the curbside exterior wall between the wheels and above the wheel well.

CAUTION: When operating with city power make very certain that the service is 110 volt and not 220 volt. Open the bumper storage compartment lid, uncoil only the needed amount of cord and plug it into the city power source. Before closing the lid, carefully place the cord in the opening provided for it.

The univolt system is a transformer designed to maintain constant output voltages regardless of the variances that occur in city power systems. The transformer design eliminates the need for complex electronic sensing systems to charge the battery, minimizing the possibility of failures and greatly increasing its overall reliability.

If your trailer is equipped with a power cord reel do not pull it out more than a foot or two past the white tape wrapped on the cord. Pulling the cord completely out to the stop will make rewinding difficult if not impossible.

APPLIANCES

AIR CONDITIONER

Manufacturer: The Coleman Company, Inc.
 Heating and Air Conditioning Group
 3050 N. St. Francis
 Wichita, Kansas 67219
 Phone: 316-832-6450

The roof air conditioner used on Land Yacht trailers is one of the most popular on the market today. In your Owner's Packet is a set of literature covering all operating and maintenance instructions. If the literature is misplaced please contact the air conditioner manufacturer or your Land Yacht dealer for replacement. A detailed service guide may be ordered from the manufacturer.

If your trailer is equipped with both a microwave oven and air conditioner option there will be a priority switch on the bottom, or inside, the galley rooflocker. This switch will allow only one, microwave or air conditioner, to operate at a time. Attempting to operate both would only overload circuits in the trailer or the receptacle and circuit you have plugged into.

The voltage to the air conditioner is critical. We commonly refer to 110 or 120 volts, but a check with a volt meter may find voltage much lower. Your air conditioner will probably not function if the current drops below 105 volts. Low voltage is usually associated with older or poorly maintained trailer parks, but many people have found their homes, built only twenty or thirty years ago, may not be capable of operating the air conditioner on some receptacles. Parking your trailer so the power cord can be plugged into a receptacle close to the fuse or circuit breaker box can alleviate the problem.

Avoid extension cords and adapters whenever possible. If an extension cord must be used it should be as short and heavy as possible to provide the most current to the air conditioner. The optional dual air conditioners will require the second power cord to be plugged in. A heavy extension cord should be used so you can plug into a different circuit. Trying to run both air conditioners through the same circuit will probably blow the fuses or trip the breaker of the park.

If high temperatures are expected you should make an effort to park in a shaded area. Starting the air conditioner early in the morning also helps. It is much easier to hold a comfortable temperature than it is to lower the temperature after the interior of the trailer is already hot.

Since a travel trailer is mobile, the cooling size of the air conditioner is a compromise between size and cooling capacity. The 13,500 BTU seems to be the most practical for RV use. If you are spending an extended amount of time in a hot, humid area you may want to discuss having a second air conditioner installed with the local dealer. Under most conditions you will find your single air conditioner performing adequately.

If you feel the air conditioner is not operating properly there is a very simple test. Two small inexpensive thermometers are all that is needed. With the air conditioner in the HIGH-COOL mode place one thermometer next to the air intake and the other thermometer in the flow of cool air being expelled. After about 5 minutes check the thermometers. A normally operating air conditioner will have at least a 15 degree difference in temperature.

The first place to check if your air conditioner has lost efficiency is the intake filters. When used consistently they should be cleaned every two weeks.

CAUTION: You may repeat the above-mentioned test using two thermometers with the filters removed to isolate the problem. But, NEVER operate the air conditioner over a long period without filters, or expensive repairs will be required.

If warranty repairs are required use only one of the air conditioner manufacturer's service centers, or an authorized Land Yacht dealer.

The roof of your Land Yacht will easily support a mechanic if a little common sense is used to keep his weight spread out. If the mechanic weighs 250 lbs., is carrying 50 lbs. of equipment, and jumps up and down on one foot, he can damage the roof. And, he can pay for the repair too!

SERVICE PROBLEMS

The following list of service problems covers only some of the more common problems which may occur and lists only the more probable causes.

In many instances it will be necessary to use the wiring diagram to check out the electrical circuits step by step starting at the power service.

PROBLEM: Nothing runs on either Hi or Low Cool.

- CAUSE:
1. Power supply dead - open circuit breaker or fuse.
 2. Faulty selector switch.

PROBLEM: Inadequate cooling but compressor and fan run.

- CAUSE:
1. Selector switch set at Low Cool.
 2. Low evaporator air flow (frost may form on accumulator). Check for a) dirty filter: b) air damper set on low: c) squirrel cage loose on motor shaft: d) fan motor not up to speed due to tight bearings, faulty fan capacitor: e) dirt and lint on evaporator coil.
 3. Moisture in system - frost periodically forms and melts on accumulator.
 4. Heat gain of RV exceeds cooling capacity of air conditioner.
 5. Low charge - leak in system.

PROBLEM: Fan runs on Low or High Cool, but compressor neither runs nor hums.

- CAUSE:
1. Selector switch open to compressor.
 2. Thermostat open.
 3. Compressor overload switch open.
 4. Compressor winding open.

PROBLEM: No cooling - compressor runs but won't pump.

- CAUSE: Compressor vane stuck (compressor must be replaced).

PROBLEM: Fan runs on Low or High Cool but compressor periodically hums for 15 to 30 seconds.

- CAUSE:
1. Low voltage. Voltage must be 115V plus or minus 10% (Minimum of 103.5V).
 2. Faulty capacitor.
 3. Start relay contacts open.
 4. Compressor start winding open or grounded.
 5. Compressor mechanically stuck.

PROBLEM: Compressor trips breaker or thermal current overload immediately - no hum.

- CAUSE:
1. Compressor winding shorted or grounded.
 2. Circuit breaker or thermal current overload faulty.

PROBLEM: Compressor cycles on and off, resulting in inadequate cooling.

- CAUSE:
1. Thermostat bulb touching metal.
 2. Thermostat out of calibration.
 3. Collar connecting blower outlet to ceiling assembly missing or too short.
 4. Compressor cutting out on overload due to: a) dirty condenser coil: b) Low or High voltage: c) overcharge or non condensables in the system: d) Low charge: e) plugged up cap tube.

PROBLEM: Fan won't run regardless of selector switch setting, but compressor runs on High and Low Cool.

- CAUSE:
1. Faulty selector switch.
 2. Fan motor windings open, shorted or grounded.
 3. Fan capacitor shorted, weak or open.
 4. Fan bearings dry.

PROBLEM: Air conditioner vibrating.

- CAUSE:
1. Fan blade or blower wheel out of balance.
 2. Motor shaft bent.

PROBLEM: No heat (Models equipped with heating elements).

- CAUSE:
1. Limit switch open.
 2. Selector switch open.
 3. Thermostat open.

SCHEMATIC WIRING DIAGRAM

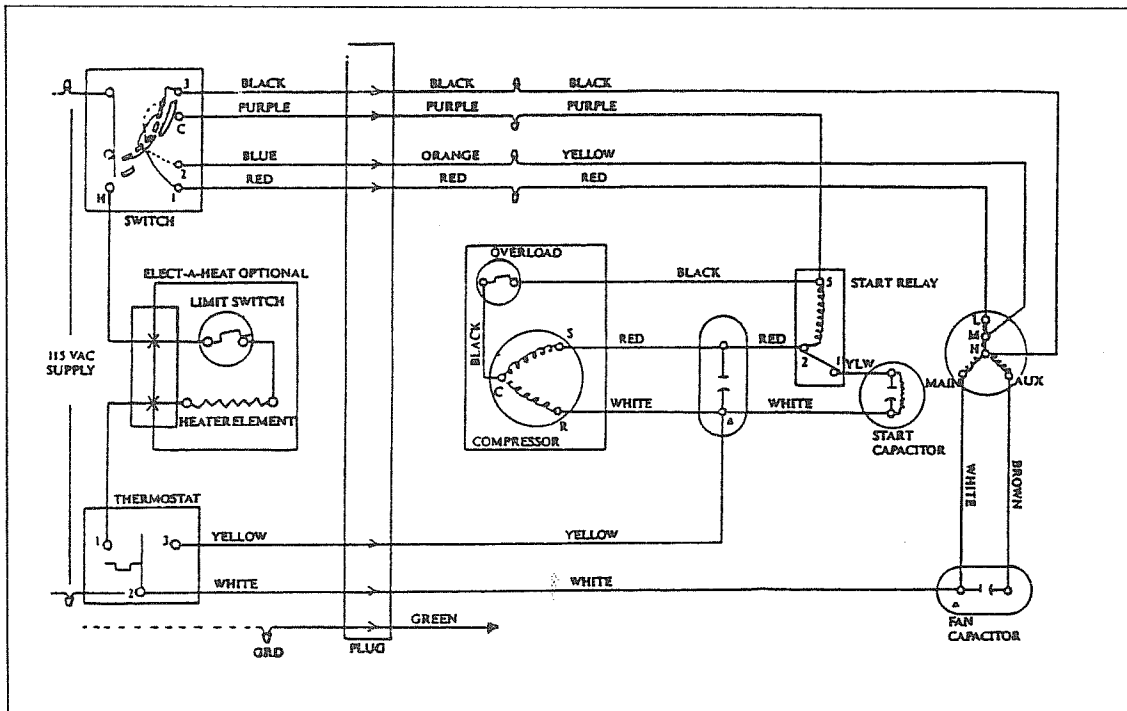

HEATING SPECIFICATIONS

SPECIFICATIONS	
Heat Output @ 120 VAC 1600 Watts	5600 BTU's
Element Resistance	5 to 7 Ohms (Rx1 Scale)
Element Amperage	10 to 12 Amps
Element Start Delay	4 Seconds Maximum
Thermostat Cycling Temperature	61° ± 5° @ Full Counter Clockwise 85° ± 5° @ Full Clockwise

Operational Characteristics

The thermostat's function is to control the temperature at which both the compressor and heating element cycle.

The air conditioner's return air temperature must fall within the ranges given in the specifications table before either compressor or heater will operate.

Temperature differential will vary from 3 to 4 degrees. Temperature differential is the amount of change required to activate the thermostat contacts.

THERMOSTAT SPECIFICATIONS

SPECIFICATIONS	
COOL	61° ± 5° @ full counter clockwise
HEAT	85° ± 5° @ full clockwise
TEMPERATURE DIFFERENTIAL	3° Minimum 4° Maximum

FAN SPECIFICATIONS

SPECIFICATIONS	
Amperage (High Speed) - full clockwise	2.7 to 3.5
Amperage (Low Speed) - full counter clockwise	3.2 to 4.4
Ohms - Main Winding	Rx1 Scale, Approx. 5.5
Ohms - Auxiliary Winding	Rx1 Scale, Approx. 40.0

AIR CONDITIONER PARTS DESCRIPTION

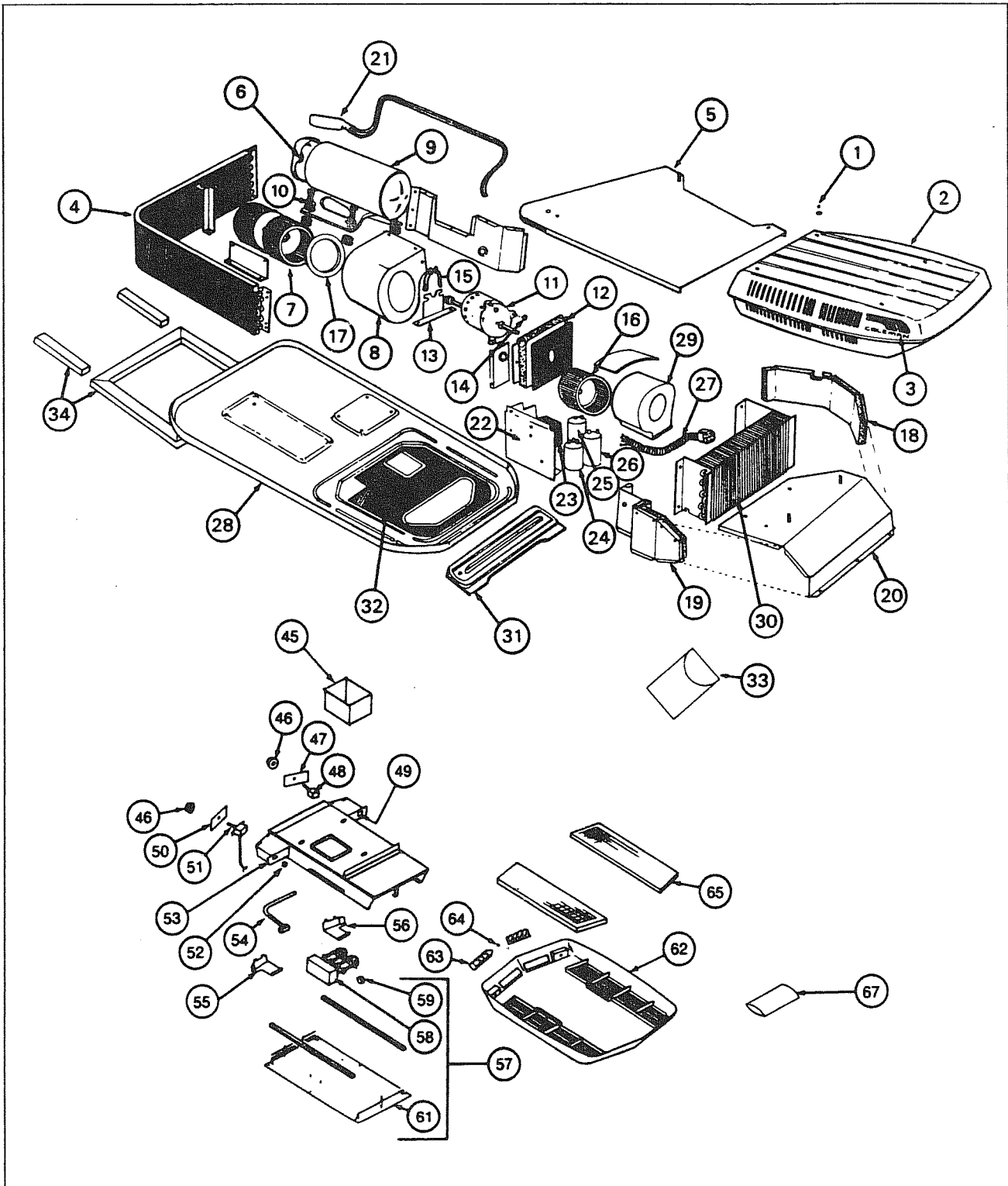

PARTS DESCRIPTION FOR PRECEDING PAGE

1. Acorn Nut/Washer
2. Shroud
3. Decal Package
4. Condenser Coil
5. Condenser Cover
6. Overload
7. Condenser Blower Wheel
8. Scroll Assy, Condenser
9. Compressor
10. Mount Pkg, Compressor
11. Motor
12. Motor Mount
13. Motor Mount Brace
14. Motor Mount Pkg.
15. Motor Strap Pkg.
16. Evaporator Blower Wheel
17. Venturi Ring
18. Evaporator Housing, Right
19. Evaporator Housing, Left
20. Top Evaporator Cover
21. Cap Tube Assembly
22. Junction Box Assy. Complete
23. Start Relay
24. Start Capacitor
25. Run Capacitor
26. Run Capacitor Fan
27. Conduit Assembly
28. Basepan Assy w/Roof Top
29. Scroll Assembly, Evap
30. Evaporator Coil
31. Evaporator Drain Pan
32. Evaporator Coil Gasket
33. Customer Envelope
34. Gasket Pkg.
35. Seal Package (not shown)
45. Duct Collar
46. Knob
47. Decal (Selector Switch)
48. Selector Switch
49. Plug Connector
50. Decal (Thermostat)
51. Thermostat
52. Grommet
53. Connector
54. Wire Bundle
55. Cover (Control Box, Right)
56. Cover (Control Box, Left)
57. Heat Strip Assy
58. Heat Element
59. Limit Switch
60. Wire Bundle
61. Heat Strip Bottom
62. Ceiling Shroud
63. Louver
64. Washer
65. Filter
66. Filter Retainer
67. Single Parts Pkg.

Model Number		SUPER MACH ROTARY		
		"Gray" 6799-702	"Beige" 6799-708	"Ivory" 6799-709
BTU Capacity (Nominal)	Cooling	13,500		
	Heating	5,600		
Electrical Rating		115V/60Hz/1 Phase		
Lock Rotor Amps	Cooling	63.5		
Full Load Amps	Cooling	14.5		
	Heating	16.0		
Running Watts	Cooling	1700		
	Cooling	2075		
Running Watts	Heating	1,800		

DIMENSIONS

EXTERIOR SHROUD	HEIGHT	9½"
	WIDTH	29"
	LENGTH	43"
CEILING PLATE	DEPTH	3"

FURNACE

Manufacturer: Hydro Flame Corporation
1874 South Pioneer Road
Salt Lake City, UT 84104
Phone: 801-972-4621

The manufacturer of the furnace in your Land Yacht has been well known in the RV industry for many years. The furnace burns LP gas, and is powered by 12 volt current from the battery or power converter when plugged into city power. Operating instructions are located in your Owners Packet. If they should become misplaced new literature can be ordered direct from the manufacturer or your Land Yacht dealer. The manufacturer also offers a detailed Service guide for your furnace.

WARNING: Carefully read all the manufacturer's instructions prior to operating. NEVER store flammable material next to the furnace.

If warranty service is required use only a service location recommended by the furnace manufacturer or your Land Yacht dealer.

LIGHTING DIRECTIONS

WARNING

THIS FURNACE IS SEALED AND CANNOT BE LIT WITH A MATCH. FAILURE TO FOLLOW THE INSTRUCTIONS EXACTLY MAY RESULT IN AN EXPLOSION AND POSSIBLE DAMAGE TO THE FURNACES AND INJURY TO THE OPERATOR.

1. Set thermostat to "OFF".
2. Turn gas off at outside LP tank and wait 5 minutes.
3. Turn gas valve to "ON".
4. Turn thermostat up until blower comes on.
5. Allow 20 seconds or more for furnace to light due to a pre-purge cycle designed into the ignition system. On initial start up in cold weather it may take up to two (2) minutes for the furnace to light.
6. If burner does not light, set thermostat to "OFF", wait 60 seconds and try again for ignition.
7. If after three tries and no ignition, go to shutdown and determine the cause. Be sure to have gas to the furnace (no air in the gas line).
8. If furnace lights, set thermostat to desired temperature setting.

FURNACE COMPONENTS

WARNING: Service and repair procedures in the following text is intended for Qualified Service Personnel use only.

Blower Assembly

The blower assembly is powered by a 12 volt DC motor. Two wheels are used. One for circulating warm air and the other for providing combustion air. See Fig. 1. The blower motor is permanently lubricated and no oiling is required. However the blower assembly, including blower wheels, should be cleaned every season to remove accumulations of dirt and lint.

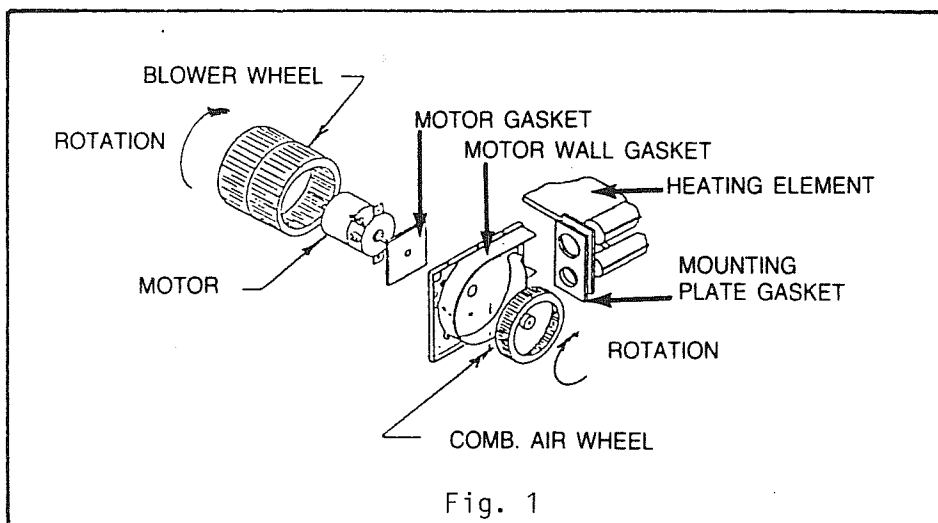

Direct Spark Ignition Circuit Board

The circuit board is located on the back of the electrical panel just behind the front door. As shown in Fig. 2 it operates in conjunction with the igniter assembly (located at the right side of the control box on the burner box assembly). To provide safe reliable ignition without the use of a standing pilot as described in the "Sequence of Operation" section, the circuit board provides an initial purge cycle of about 20 seconds. During this time only the blower runs so that any unburned gases are purged out of the heat exchanger, prior to ignition.

This purge cycle time is unique to the circuit board used by Hydro Flame and is not the same as most other circuit boards used by other manufacturers. Therefore, it is essential to use only the Hydro Flame Circuit Board if a replacement is required. Hydro Flame circuit board has a protective cover added to the assembly to give added protection from handling and moisture. See Fig. 2.

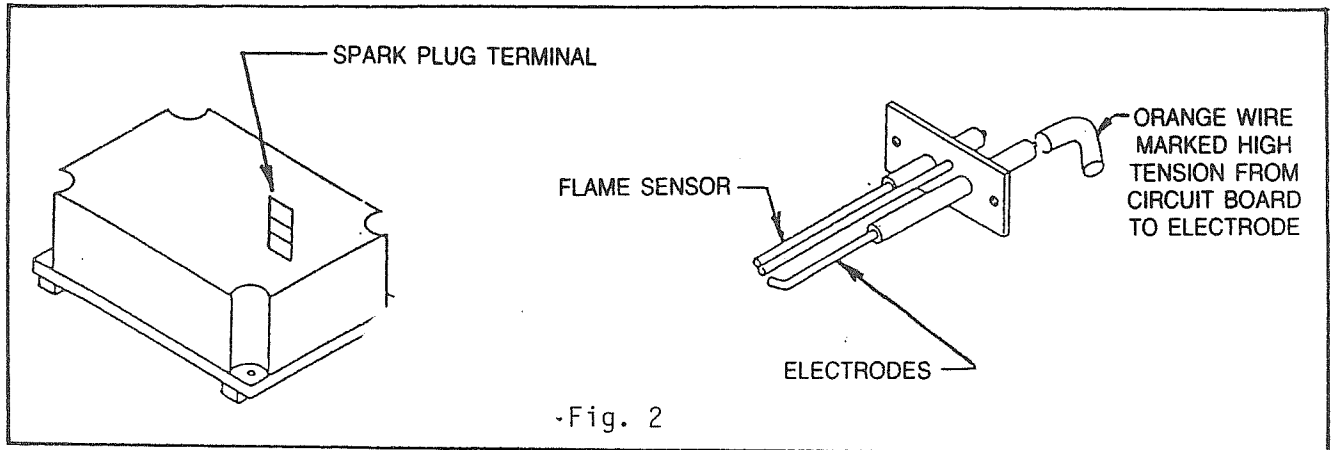

The electrode assembly consists of two electrodes and one flame sensor probe. The spark produced by the circuit board to the electrodes ignites the burner after the purge cycle is completed. The flame sensor probe senses the heat from the burner and signals the circuit board to keep the gas valve open. If ignition does not occur so that the flame sensor does not sense heat, the circuit board will shut the gas valve off within 6 to 9 seconds.

Burner Assembly

To remove the burner assembly from the control box, first remove the draft shield assembly by opening the front door catches and unscrewing the wing nut located on the side of the combustion air housing cover and front screw. See Fig. 3. Next unscrew the manifold from the blower wall and remove the three (3) screws on the burner box.

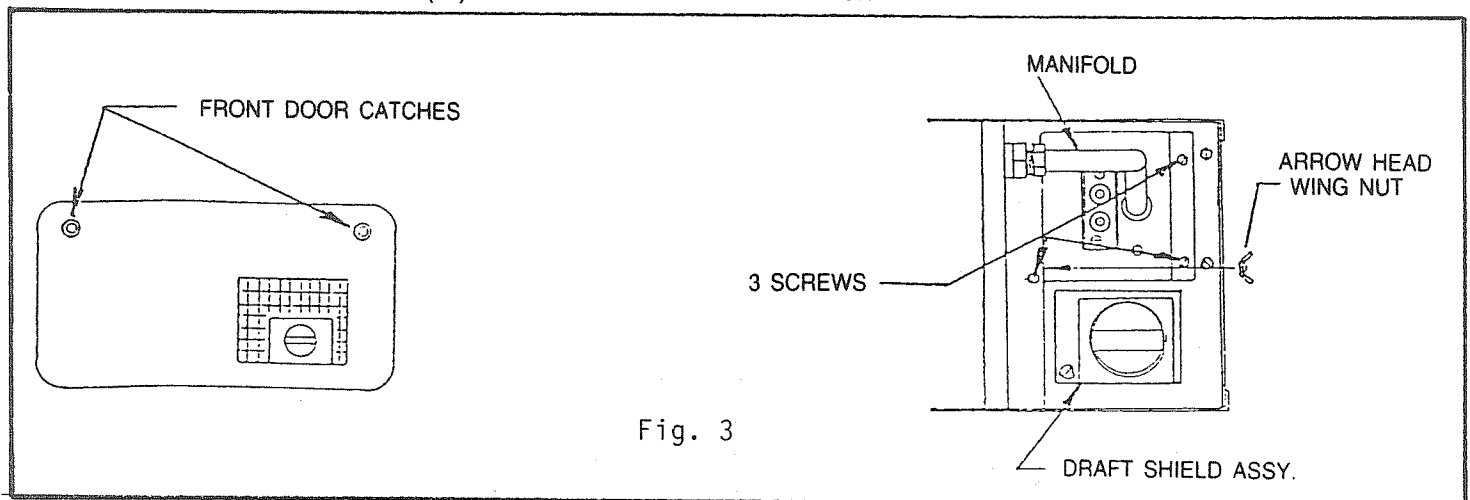

Pull manifold to the right until manifold clears the brass fitting. Now remove burner assembly by pulling the manifold toward you and disconnecting the electrode wires.

CAUTION: When re-installing the burner assembly make sure the two screws on the burner box flange are secure and not stripped.

Air Seal Gaskets

In order to prevent leakage of combustion air from the sealed system, there are gaskets in the following places. These gaskets must be in place and undamaged. See Fig. 4 for gasket locations.

1. Heat exchanger gasket.
2. Motor wall gasket.
3. Motor gasket.

Heat Element Assembly

The heat element assembly can be removed in order to service the exchanger or the heat element gasket. Follow the steps listed:

1. Turn off gas at LP tanks.
2. Disconnect gas line from left side of furnace.

WARNING

Fire or explosion may result when gas line is disconnected at the furnace and the gas bleeds out. Check all appliances which have a pilot still burning and extinguish them or any other flame source in the vicinity.

3. Unplug the electrical plastic disconnect plug from the left side of the furnace.
4. Remove six screws on the left inside of the control box and the two screws on the right inside of the control box. See Fig. 4.
5. Remove the twelve screws holding the front door on.
6. Pull the entire control box assembly forward where it can now be serviced and bench tested.
7. Remove burner assembly as described earlier and remove three remaining screws holding element assembly to control box.

CAUTION: When re-installing heat element assembly and control box assembly, be sure all screws are firmly in place.

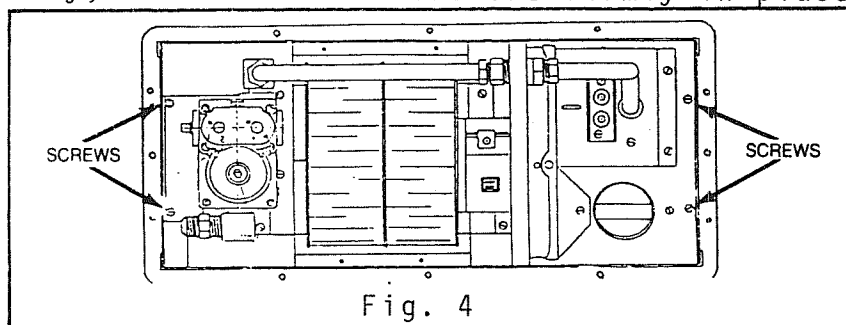

Fig. 4

SEQUENCE OF OPERATION

- A. On stand by the +12 VDC is connected to terminal #3 of the fan relay which is closed. The voltage will extend (1) through the red wire to terminal #1 of the open fan relay, (2) through another red wire to the limit switch, (3) through the limit, (4) through the red wire to the sail switch. See Fig. 5.

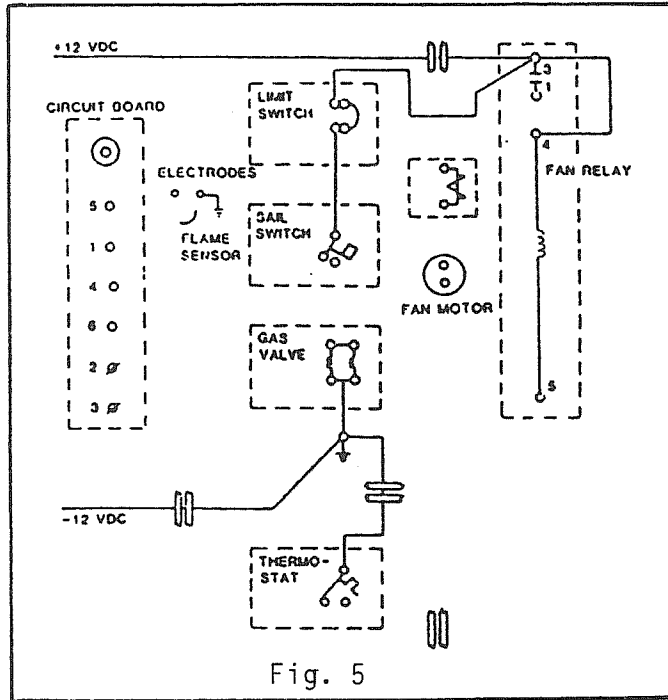

Fig. 5

- B. When the temperature inside the RV drops to the set temperature of the thermostat, the thermostat contacts close to (1) switch -12 VDC to terminal #5 of the fan relay terminal, (2) through the yellow wire to -12VDC ground, thus the fan relay coil is energized. See Fig. 6

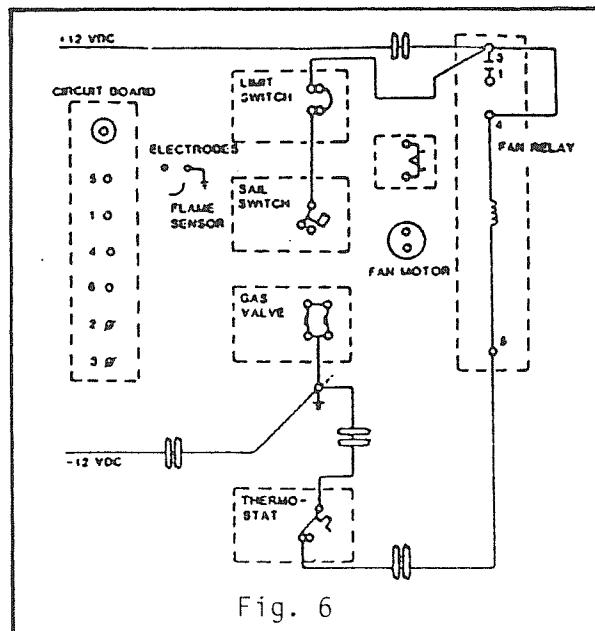
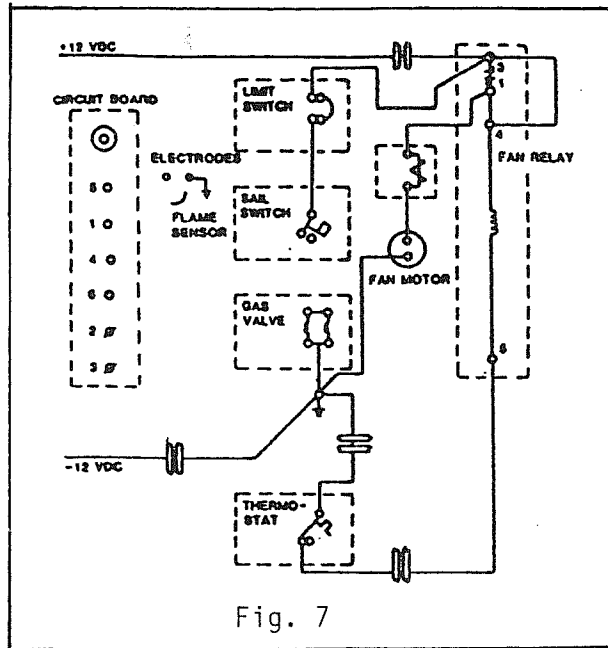

Fig. 6

- C. With the fan relay coil energized, the contacts of the fan relay will close and the +12 VDC will pass (1) through the contacts from #3 to #1, (2) through the red wire to the circuit breaker, (3) through the circuit breaker, (4) through the red wire to the motor, (5) through the motor, (6) through the black wire to the ground system. Thus, the fan motor runs. See Fig. 7.



- D. As the fan comes up to speed the air current will close the sail switch and the +12 VDC will pass (1) through the sail switch, (2) through the wire to the #1 terminal of the circuit board.

NOTE: The ground side of the circuit board is established from terminal 6 through the red wire to the grounded side of the fan relay. When the circuit board is energized, it will start the 20 second count down of purge time. See Fig. 8.

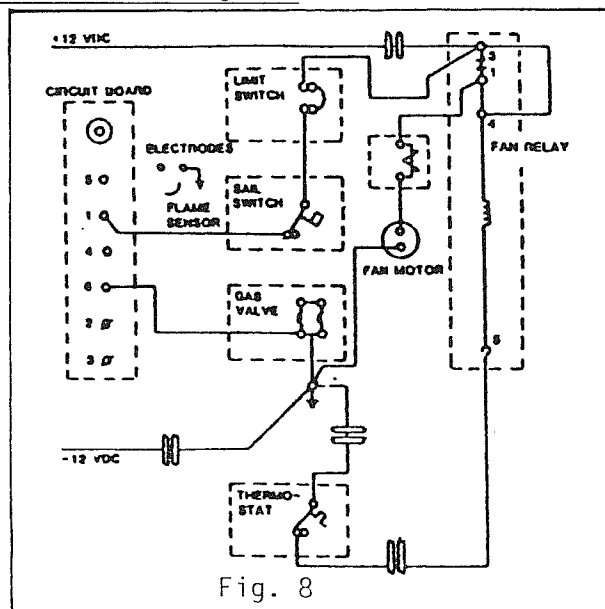

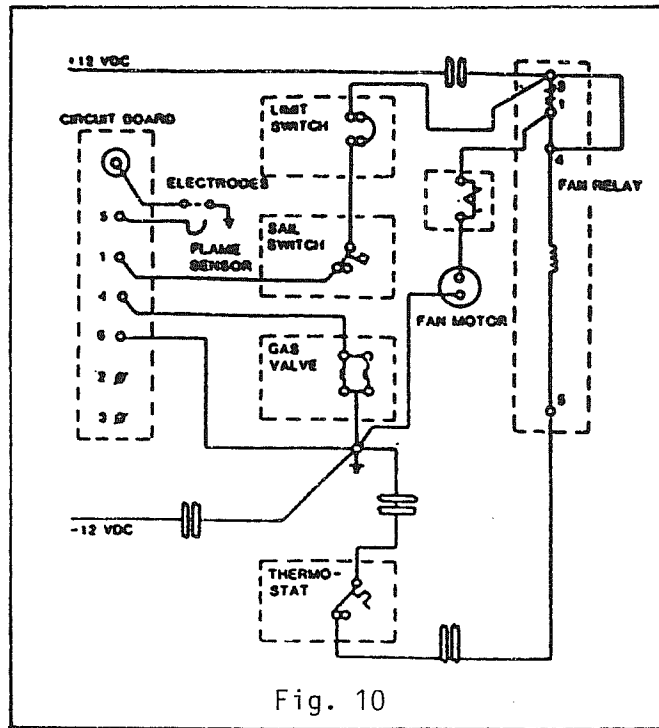

Fig. 10

- G. When the temperature of the RV rises above the thermostat set temperature, the thermostat will open and disconnect the -12VDC to terminal #5 of the fan relay. The the gas valve will close and the fan relay contacts will open, after a cool down period of 1 to 2 minutes for the heat in the fan relay coil to be extracted. See Fig. 11.

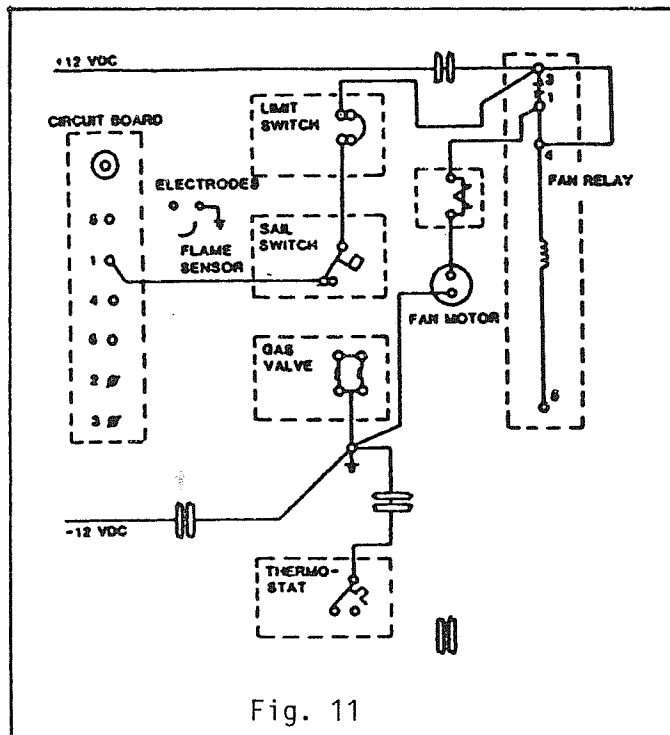
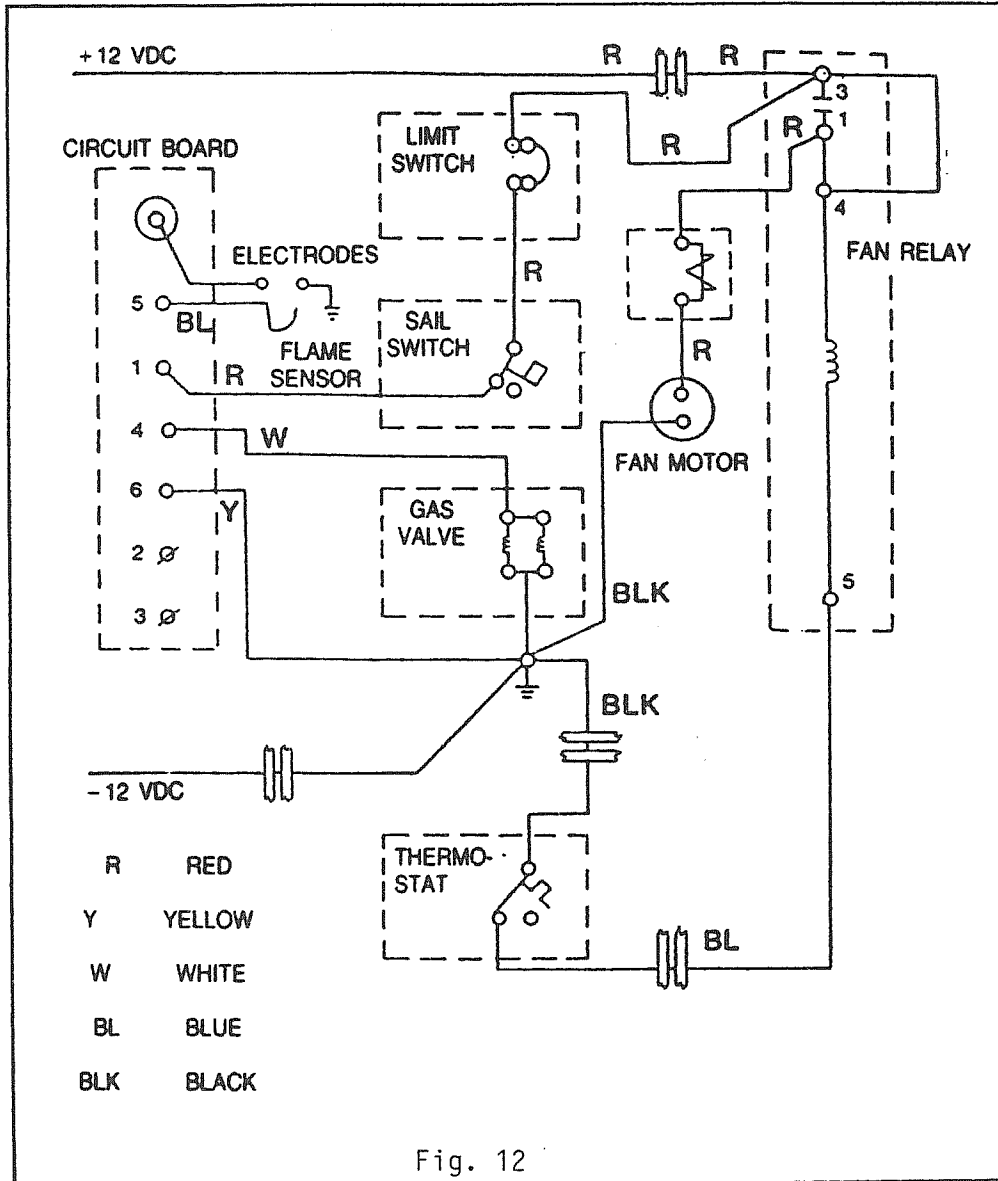
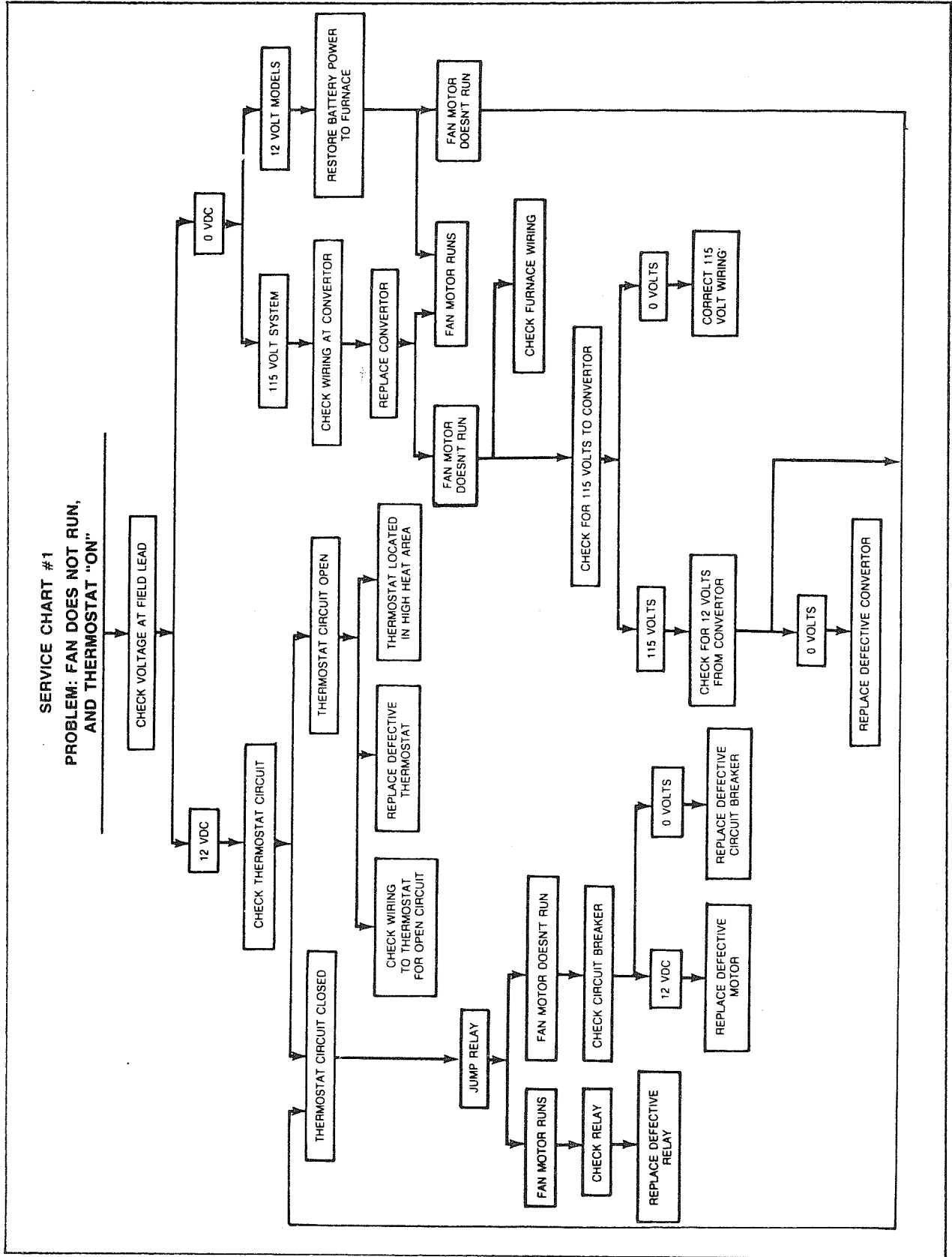

Fig. 11

The complete wiring diagram, with all switches in their normal positions is shown in Fig. 12.



TROUBLE SHOOTING



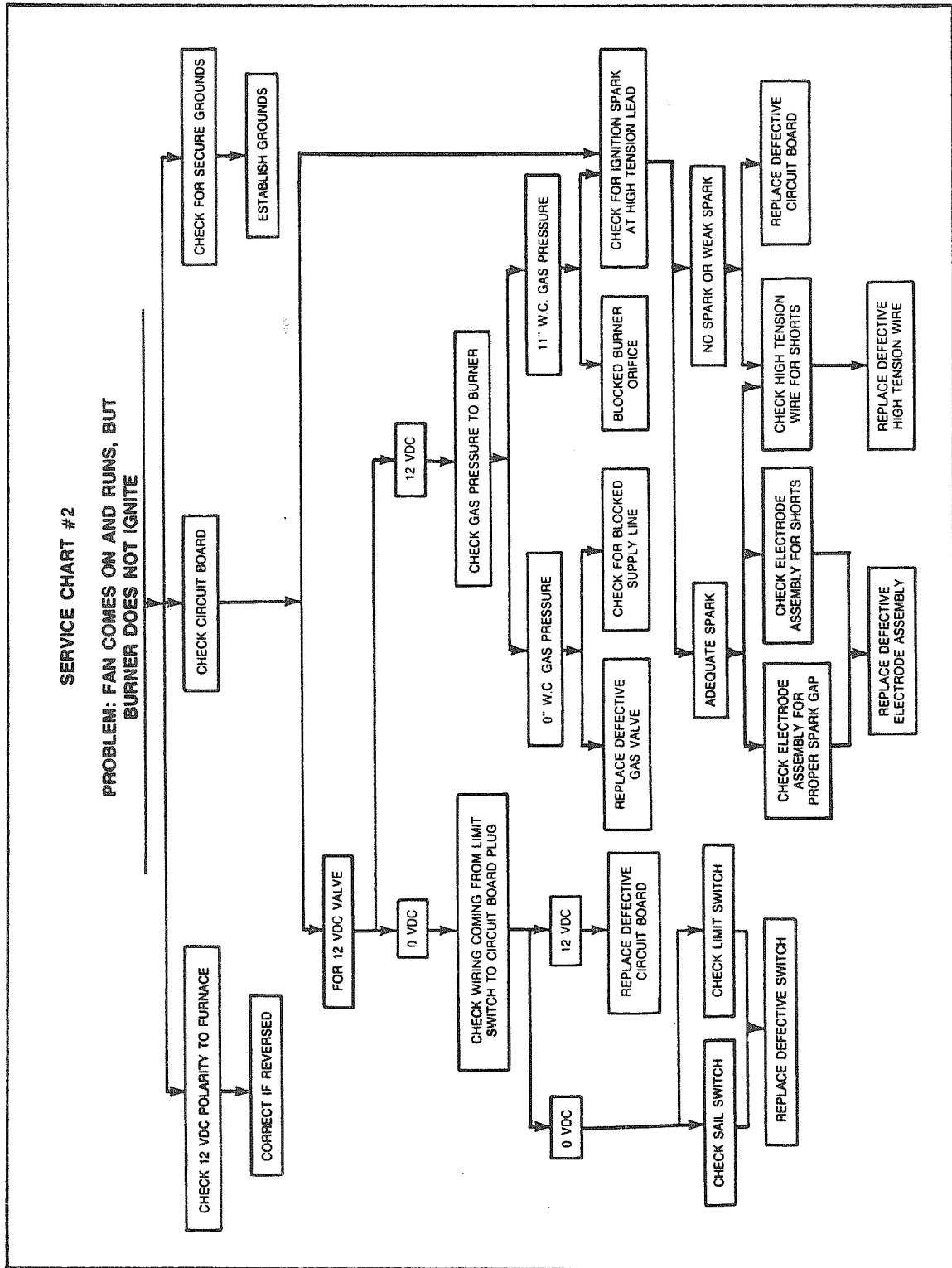

Trouble Shooting Continued....

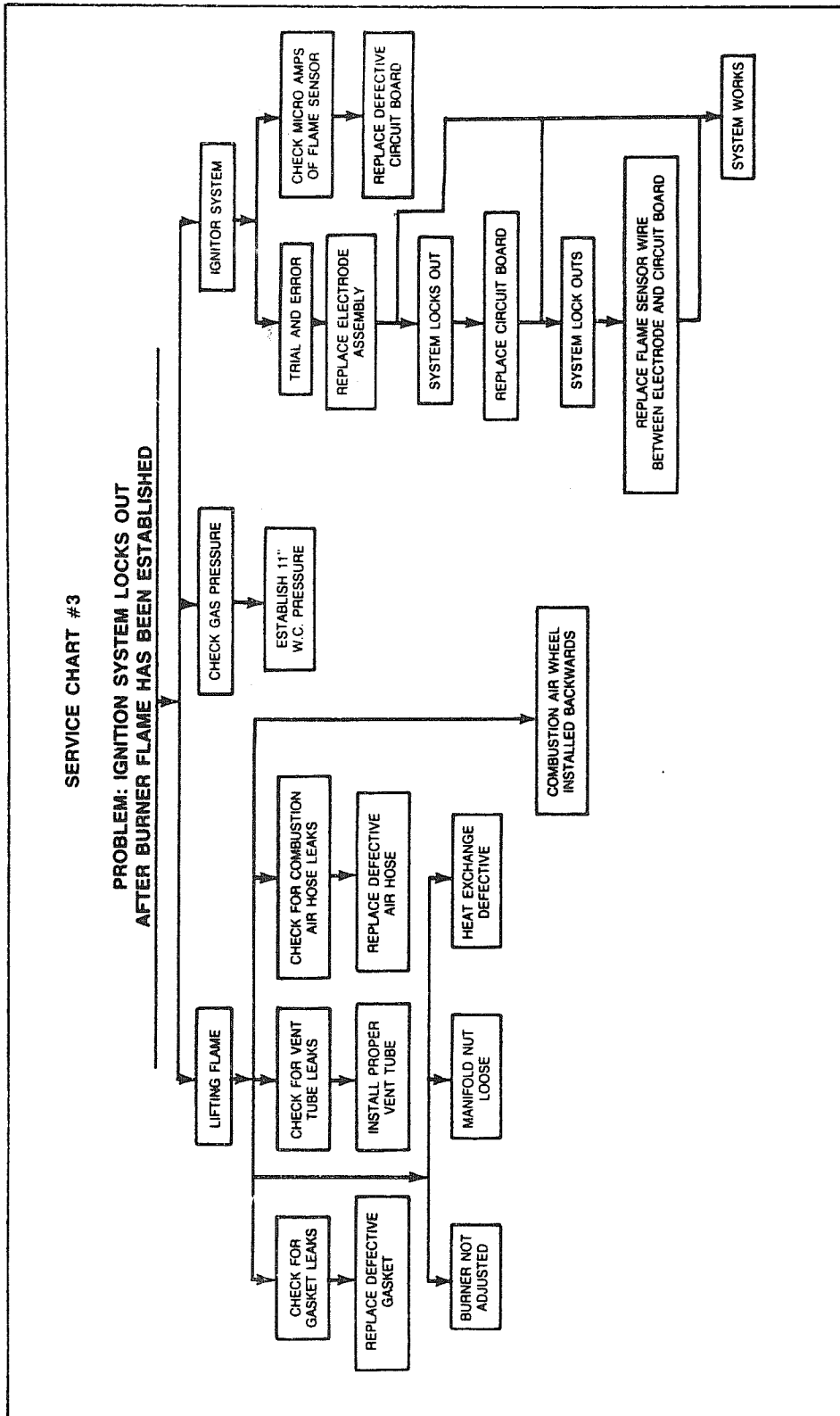

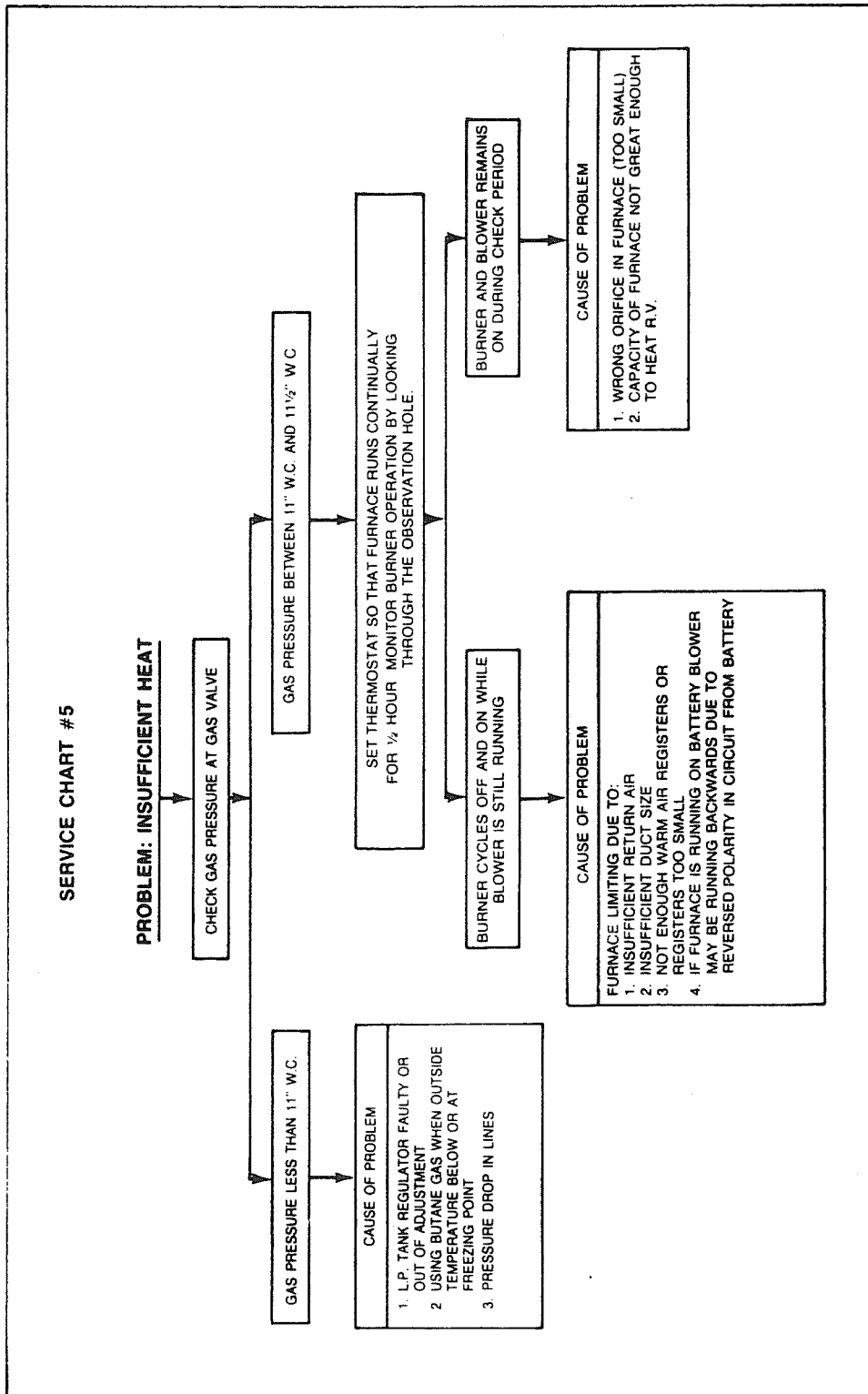

Trouble Shooting Continued....

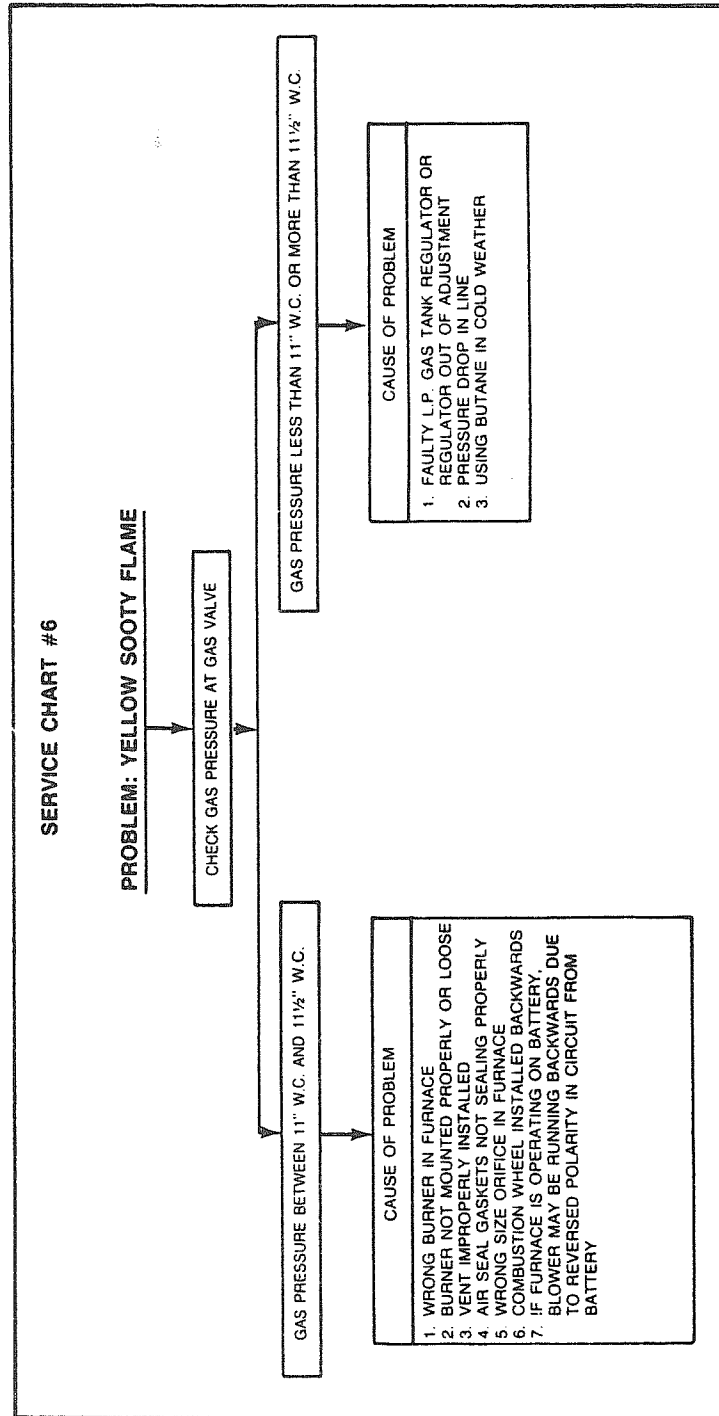

FURNACE PARTS LIST (Models 8531 and 8535)

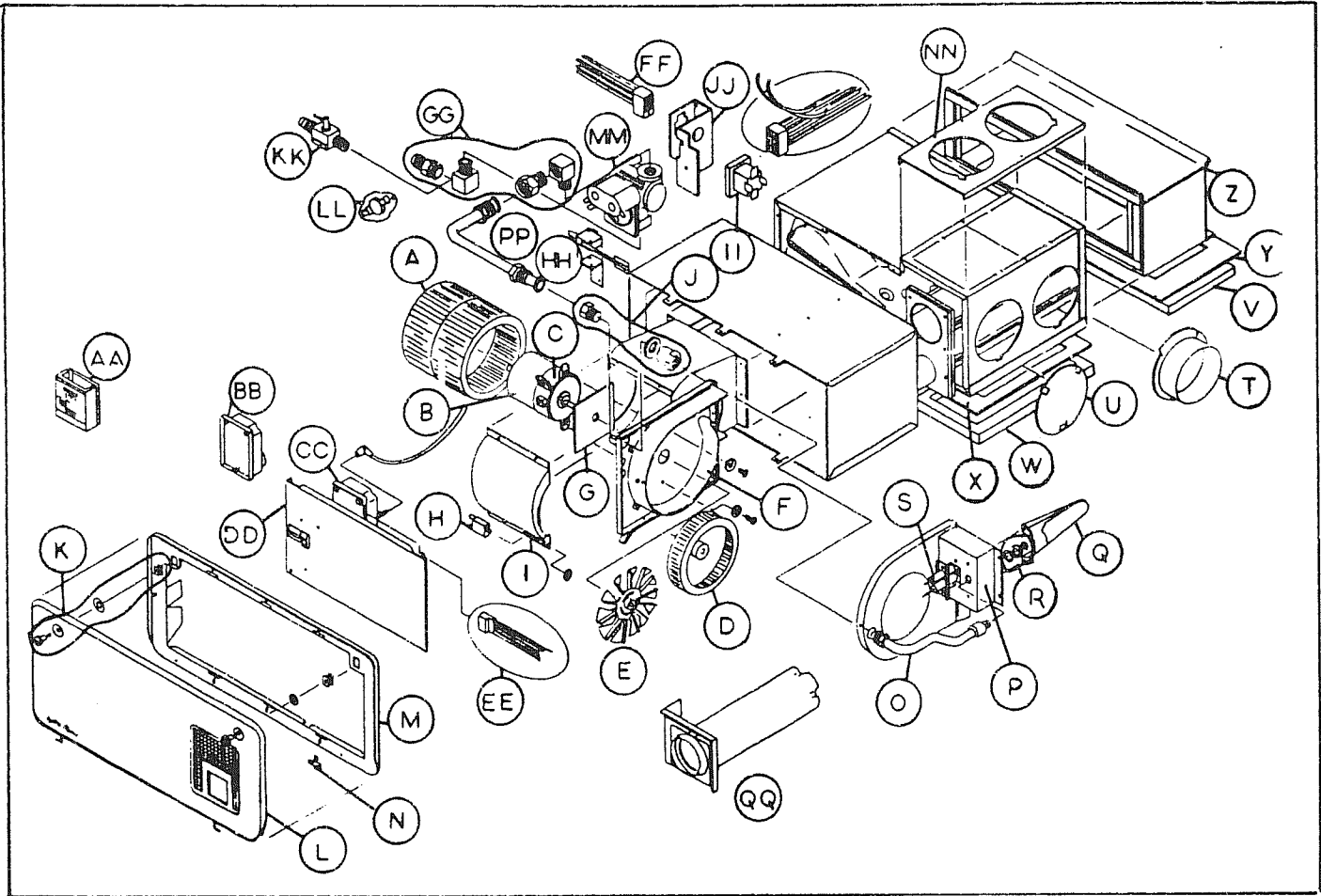

- | | |
|----------------------------------|----------------------------------|
| A. Blower wheel | V. Large Bottom Gasket |
| B. Motor | W. Small Bottom Gasket |
| C. Motor Bracket Assembly | X. Top Bottom Plenum Plate |
| D. Combustion Wheel | Y. Bottom Plenum Plate |
| F. Motor Mounting Wall Assy | Z. Bottom Extension Adapter |
| G. Motor Gasket | AA. Thermostat |
| H. Circuit Breaker | BB. Itt D.S.I. Board |
| I. Blower housing back cover | CC. Fenwal D.S.I. Board |
| J. Motor Wall Brass Fittings | DD. Electrical Panel Assy |
| K. Door catch and latch assy (2) | EE. Electrical Panel Wiring Assy |
| L. Front Door Panel Assy | FF. Electrical Field Hookup |
| M. Outer Bezel Assy | GG. Valve Brass Fittings |
| N. Door hinge clip (2) | HH. Sail Switch Assy |
| O. Manifold right side | II. Relay |
| P. Burner bos Assy | JJ. White/Roger Valve Bracket |
| Q. Burner Assy | KK. Brass Shut Off 3/8 x 3/8 |
| R. Orifice and Manifold nut | LL. Limit Switch |
| S. Electrodes | MM. White/Roger Valve |
| T. Duct Adapter | NN. Bottom Discharge Cover |
| U. Duct Cover Plate | PP. Manifold Left Side |
| | QQ. Draft Cap Assy |

RANGE AND OVEN

Manufacturer: Magic Chef, Inc.
28812 Phillips Street
Elkhart, Indiana 46514
Phone: 219-264-9578

The range and oven in your Land Yacht works on LP gas. The only electrical power used is by the 12 volt light in the oven.

People using gas ranges in their home will find little difference in the operation of the range in the trailer. Other customers, used to electric ranges, may be a little apprehensive at first, but will quickly gain confidence. The basic operation of the gas ranges has been the same for many years; but, please be sure to read all the directions furnished by the manufacturer and located in the Owner's Packet. Excellent service and parts manuals are available from the manufacturer.

We find many experienced Rvers do not use the pilot light for the top burners, preferring the flint type hand lighters instead. The main reason the pilots aren't used is due to the size of the trailer and the climate in which most trailers are used. The pilots are very small, but, of course, produce heat that may be noticeable in the trailer. With limited counterspace it is normal to set articles on the closed top of the range. If the day is hot and the article is plastic it may become deformed from the low but constant heat of the pilot.

OPERATION PRINCIPLE

TOP BURNERS

The manifold along the front of the top burner section is continually pressurized as long as the LP tank valve is open. Upon opening any of the burner valves this gas is injected through the burner orifice and into the venturi (mixing tube) where it mixes with primary combustion air and flows on to the burner. At this point the gas/air mixture is evenly discharged through the ports in the burner cap where ignition occurs (by use of a match or pilot light if applicable). The amount of primary air may be adjusted on earlier models to alter combustion characteristics.

OVEN

(Main Burner)

The fuel supply for the oven burner is taken from the manifold in the top section of the range. The tube leading from the right hand side of the manifold extends down the rear of the range and into the automatic oven safety valve (on newer models this gas flow is taken at the thermostat mounted on the manifold. A tube leads from the thermostat to the oven safety valve). When this valve opens, gas passes through it to the burner orifice. The orifice meters the gas flow into the

burner venturi, where it mixes with primary combustion air and enters the burner casting. The oven pilot ignites this mixture resulting in flame evenly spread around the burner.

(Pilot Burner)

The pilot burner is actually two pilots in one:

1. The STANDBY PILOT is that portion of the pilot light which burns constantly, providing that the LP tank and manifold valve (if applicable) are on. It ignites the gas-air mixture at the burner when the oven valve opens. It also provides the base for the heater pilot.
2. The HEATER PILOT is actually an extension of the standby pilot. It is on only when the oven thermostat "calls for heat". The purpose of the heater pilot is to open the oven safety valve thereby enabling gas to flow to the oven burner.

(Thermostat)

The thermostat is probably the most important component part in the functioning of the oven. It regulates the temperature of the oven keeping it at the desired cooking temperature. Thus, the thermostat is conducive to excellence in oven cooking. It is the thermostat (directly behind the oven control knob) that increases the "Standby pilot" to the "heater pilot" flame.

The thermostat "senses" the oven temperature by means of a "thermal bulb" located in the top of the oven. This bulb is filled with gas and connected to a bellows in the thermostat by a capillary tube. When the oven is on: (1) the bulb heats up, (2) the gas expands, (3) causing the bellows in the thermostat to expand, (4) a mechanical linkage within the thermostat shuts off the higher flow of gas to the pilot burner and throttles the amount down considerably. The pilot flame ceases to burn at the heater position, but continues at standby.

As the temperature begins falling in the oven, the above described re-occurs, except now (1) the bulb cools, (2) the gas contracts, (3) the bellows in the thermostat contracts, (4) the mechanical linkage in the thermostat then causes an increasing amount of pilot gas to flow and the pilot goes to the heater flame position.

NOTE: On the newer model ranges the thermostat will have a "pilot off" or "Pilots off" position on the thermostat knob. With the thermostat set at this position, all gas is shut off from the oven pilot "pilot off". When the thermostat is set on the "pilots off" position all gas to the top pilot and oven pilot is shut off.

(Oven Safety Valve)

This valve controls the gas flow to the main burner. The valve is operated by a thermal bulb in the heater pilot flame. This bulb is connected to a bellows in the valve by a capillary tube. When the bulb is heated it expands the mercury in it, expanding the bellows and opening the valve. The opposite occurs when the heater pilot flame subsides.

SEQUENCE OF OVEN OPERATION:

With the thermostat set a 350⁰, for example, the following steps automatically occur:

- a. The thermostat "calls" for heat (see thermostat operation principle)
- b. The pilot flame increase to the heater position (see thermostat operation principle)
- c. The oven valve opens (see "Oven Safety Valve") and lets gas into main burner
- d. Burner heats up oven and thermostat quits calling for heat
- e. Pilot heater flame subsides
- f. Oven safety valve closes
- g. Oven is ready for another cycle

TROUBLE SHOOTING

(Top Burners)

The possibility that a service call on the top burner portion of the range will require anything more than minor adjustments and/or cleaning is very remote.

Combustion problems may occasionally arise, but these can normally be attributed to an accumulation of dirt, grease, dust, or spider webs, etc. in the venturi or the burner.

(Pilot Adjustment)

On models ordered from the factory with top burner pilots, these pilots may need to be checked in cases of (1) burners not igniting, or (2) soot accumulating within top burner section. The proper setting for this pilot is when the flame burns blue with a slight yellow tip. The tip of the flame should be about even with the top of the body of the lighter.

TROUBLE SHOOTING

PROBLEM: No constant pilot

- CAUSE/
REMEDY:
1. No gas to range.
Use top burner or other constant gas supply outlet to check gas supply.
 2. Constant pilot adjustment turned off.
Adjust constant pilot adjustment .
 - a. Single tube pilot - set either to Natural (N) or LP GAS (LP) position.
 - b. Two tube pilot - turn adjustable cartridge to obtain stable blue flame approximately 3/8" long
 3. Tubing supply line blocked.
Disconnect tubing at source and at pilot end and blow out to clear passageway.
 4. Orifice blocked.
 - a. Single tube pilot - disconnect tubing from pilot and blow out, to clear orifice. NOTE: DO NOT ream or drill out orifice hole.
 - b. Two tube pilot - disconnect tubing from pilot and blow out to clear orifice. NOTE: These orifices may be reamed out with a small needle to clear blockage.
 5. Pilot blocked.
Disconnect tubing from pilot. Remove orifice from pilot and clean out blockage or replace pilot.
 6. Pilot too close to oven burner flame.
Adjust position of pilot assembly. (See Fig. 8 below)

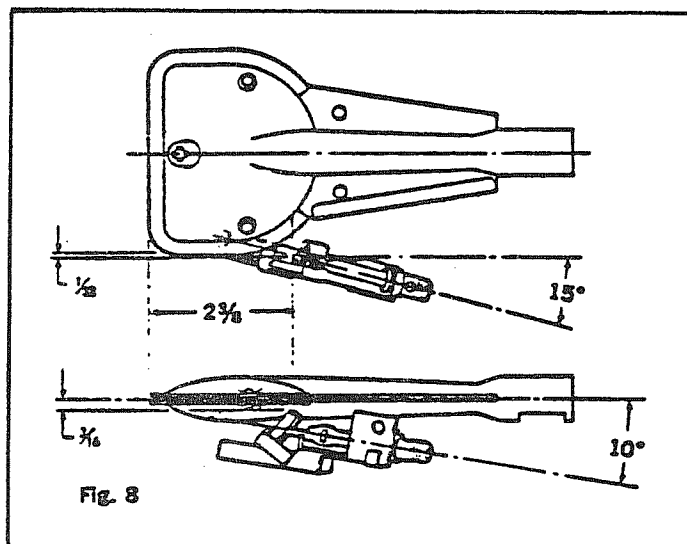

PROBLEM: Unstable constant pilot flame (Pilot flame flutters - two tube pilot only)

- CAUSE/
REMEDY:
1. Insufficient gas.
 - a. Reset constant pilot adjustment and/or check for blockage of orifice.
 - b. If gas pressure too low, check pressure regulator (if applicable) and increase pressure.
 2. Shield under constant pilot too close to pilot tube. Check spacing by inserting a quarter between shield and pilot tube. Snug fit indicates proper spacing. Carefully bend shield to obtain proper spacing.

PROBLEM: No heater pilot.

- CAUSE/
REMEDY:
1. Thermostat turned off.
Turn thermostat knob to setting above oven temperature.
 2. Heater pilot adjustment turned off.
Reset heater pilot adjustment until flame just envelopes flame responsive element.
 3. Tubing supply line blocked.
Refer to "Tubing Supply line blocked" under "No constant pilot".
 4. Orifice blocked.
Refer to "Orifice blocked" under "No constant pilot".
 5. Pilot blocked.
Refer to "Pilot blocked" under "No constant pilot".

PROBLEM: Oven will not maintain proper baking temperatures.

- CAUSE/
REMEDY:
1. Oven bulb not in proper location (on its oven clips).
Secure oven bulb in clips that hold it in proper location. Oven bulb should not touch any surface. Approx. 1/2" away from surface of oven drum top.
 2. Oven bulb coated with foreign material, oven cleaner, etc.
Use fine steel wool or scouring pad and gently clean surface of bulb. NOTE: Recheck location of bulb.
 3. Oven bottom improperly positioned.
Reposition according to range manufacturer's instructions.
 4. Oven bottom covered with aluminum foil.
If foil blocks holes or slots in oven bottom, oven heat distribution will be affected. Remove foil.

5. Heater pilot flame not cycling off.
 - a. (Single tube pilot) High pressure could cause the constant pilot flame to act as a heater pilot flame. Check pressure and proceed as follows: (1) Pressure Regulated Appliance. Check pressure and adjust regulator if necessary, according to range manufacturer's instructions. (2) Non Regulated Appliance. Turn constant pilot selector cartridge to LP position to correct for high pressure natural gas.
 - b. Replace thermostat if problem is not due to Step A.

6. Safety device not closing. Flame responsive element (mercury bulb) is being heated by the oven burner flame due to either improper location or an over-rated oven burner.

Check the following:

 - a. Flame responsive element must be properly located on pilot burner.
 - b. Pilot burner must be properly located on bracket.
 - c. Bracket must be in proper location. (See Fig. 4)
 - d. Oven burner rate.

7. Safety device not closing (when flame responsive element is not being heated).

Replace safety device with an exact replacement.

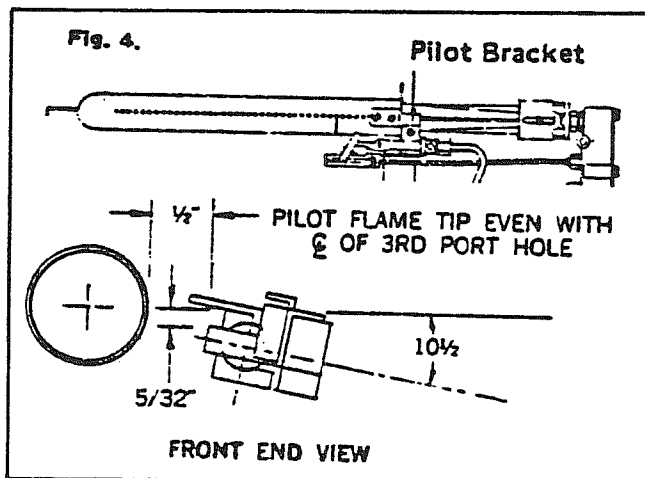

PROBLEM: No main burner flame.

- CAUSE/
REMEDY:
1. Thermostat set lower than actual oven temperature.
Reset knob to higher temperature.
 2. Oven burner orifice closed.
Readjust to range manufacturer's rated input.
 3. Flame responsive element (mercury bulb) not hot enough.
 - a. Check position of flame responsive element. It MUST be enveloped in the heater pilot flame. If not, adjust flame.
 - b. Check gas pressure - low pressure may give insufficient heater pilot flame.
 - c. Check pressure regulator (if applicable). An erratic or malfunctioning pressure regulator may cause pressure to be low.
 4. Defective thermostat - no heater pilot flame, no main burner flame at any setting.
Replace thermostat. NOTE: No heater pilot flame could be due to 3B or 3C above. Check pressure before replacing thermostat.
 5. Defective safety.
Replace safety. NOTE: No field adjustments on this control.

OVEN THERMOSTAT REMOVAL AND REPLACEMENT

1. Shut off gas at LP gas tanks.
2. Remove main top and grates.
3. Disconnect pilot fuel lines and 1/4 main fuel line at thermostat.
4. Remove two screws mounting thermostat to manifold pipe.
5. Open oven door and remove capillary bulb clips in top of oven.
6. Pull capillary bulb up through top of stove and remove thermostat.
7. To install, reverse above procedure. Be sure thermostat gasket is in place before installing thermostat.
8. Check for gas leaks at all connections with soap solution.

OVEN AUTOMATIC SHUT-OFF VALVE REMOVAL AND REPLACEMENT

1. Shut off gas.
2. Remove oven racks and oven bottom. Oven bottom is removed by pushing oven bottom toward back of oven. Then lift up front of oven bottom to release catches, pull oven bottom forward.
3. Remove mounting screw from oven burner and remove burner.
4. Disconnect 1/4 supply tube from shut-off valve.
5. Loosen screw holding sensing bulb to pilot light assembly.
6. Remove sensing bulb.
7. Remove 2 screws attaching automatic oven shut-off valve support and remove automatic oven shut-off valve.
8. To install, reverse above procedure.
9. Check for gas leaks at all connections with soap solution.

OVEN BURNER REMOVAL AND REPLACEMENT

1. Shut off gas.
2. Remove oven racks and oven bottom.
3. Remove mounting screw from oven burner and remove burner.
4. To install, reverse above procedure.

OVEN PILOT LIGHT ASSEMBLY REMOVAL AND REPLACEMENT

1. Shut off gas.
2. Remove oven racks and bottom.
3. Remove screw holding sensing bulb to pilot assembly.
4. Remove sensing bulb from pilot assembly.
5. Remove pilot fuel tube.
6. Remove nut and bolt attaching pilot assembly to support.
7. Remove pilot assembly.
8. To install, reverse above assembly.
9. Check for gas leaks at all connections with soap solution.

REMOVAL OF RANGE TOP BURNER VALVE

1. Shut off gas supply at bottles.
2. Remove knobs.
 3. Remove burner grates, main top and top burners.
4. Remove two bolts from thermostat and raise slightly to permit removal of manifold.
5. Remove gas inlet tube from half union and move tube out of way.
6. Remove two screws, one from each end of manifold assembly.
7. Remove manifold assembly from range.
8. Remove defective valve (screw counter clockwise).
9. To install, reverse above procedure.
10. Before installing new valve, apply LP pipe sealant to threads.
11. Check for gas leaks at all connections with soap solution before igniting burners.

RANGE TOP PILOT LIGHT ADJUSTMENT FOR RANGE SO EQUIPPED

1. Remove thermostat knob to provide access at adjusting screw. Adjusting screw is located at bottom right corner of thermostat.
2. Adjust so that the tip of the flame is just over the edge of the inner cone and the top burners light within four seconds.

RANGE REMOVAL

1. Turn off gas at LP bottles.
2. Raise burner cover and disconnect gas line from manifold.
3. Remove 4 Phillips head screws going through side trim into edge of counter top.
4. Slide range out.

WARNING: Check gas connection with soap solution when range is reinstalled.

RANGE/OVEN PARTS DIAGRAM

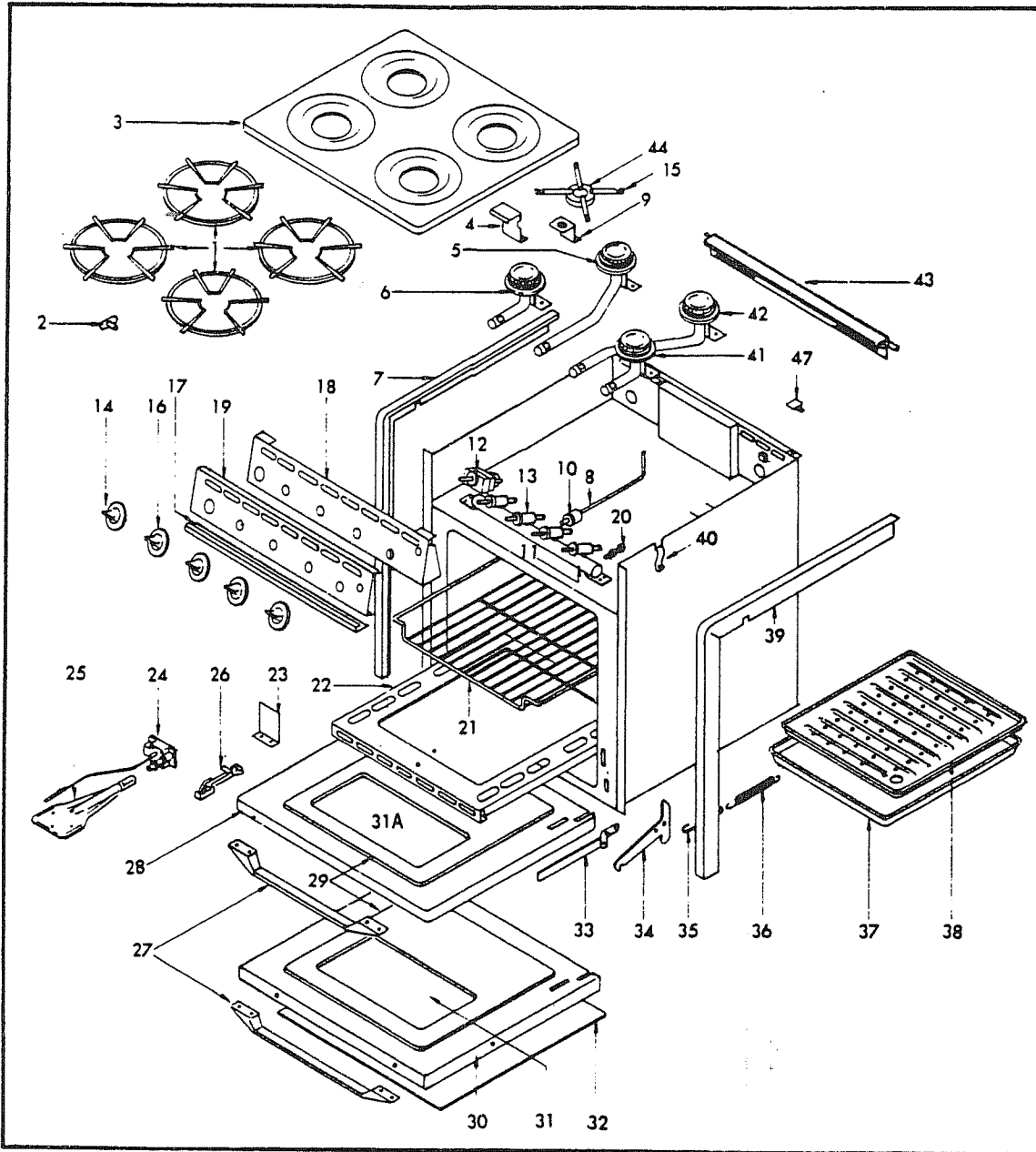

PARTS DESCRIPTION FOR PRECEDING PAGE

1. Top Burner Grate
2. Tee-nut
3. Main top
4. Top pilot shield
5. Left rear burner
6. Left front burner
7. Left side trim
8. Pilot tube
9. Top pilot support
10. Pilot filter
11. Manifold pipe
12. Thermostat
13. Top burner valve
14. Thermostat dial
15. Flash tube
16. Top burner control knob, front
17. Top burner control knob, rear
18. Manifold panel back-up
19. Manifold panel trim
20. Half union
21. Oven rack
22. Oven bottom
23. Broiler pan stop
24. Mercury control valve (LP gas only)
25. Oven burner
26. Oven pilot
27. Door handle
28. Door panel
29. Door liner
30. Glass door frame
31. Inside glass
- 31A. Window assembly
32. Outside glass
33. Door hinge assembly
34. Spring hinge arm
35. Spring hook
36. Door spring
37. Broiler pan
38. Broiler pan insert
39. Side trim, right
40. Main top hold down clip
41. Right front burner
42. Right rear burner
43. Flue deflector
44. Top pilot lighter
45. Oven rack clip
46. Grate clip, package
47. Spring, main top rear

REFRIGERATOR

Manufacturer: Dometic Sales Corporation
2320 Industrial Parkway
P.O. Box 490
Elkhart, Indiana 46515
Phone: 1-800-443-3324 or 219-295-5228

The refrigerator in your Land Yacht is an absorption type that works on either 110 volt city power or LP gas. For proper operation the refrigerator must be level in order for the refrigerant to circulate properly. In each refrigerator a round level has been provided. When parking the trailer set the level in the freezer box (it may be left in the freezer without being damaged) and adjust the trailer until the bubble stays within the circle. Most experienced RVers invest in an adjustable level that mounts on the front of the trailer. The level is set so it duplicates the refrigerator level. Refrigerators will sometimes operate if they are not level, but at the same time they are being damaged in such a way it may be necessary to replace a costly cooling unit prematurely.

Operating instructions are in your Owner's Packet and by the refrigerator controls. The manufacturer can provide a detailed parts list and will soon have a diagnostic guide available.

It is illegal in some states to travel with the LP bottles turned on, and you may worry about food spoilage when traveling all day without the refrigerator operating. Experience has shown if you start the refrigerator a day before you travel so all items are good and cold, the refrigerator seals well enough to prevent any problems. In warm weather you may want to turn the refrigerator on for an hour or so when you stop for lunch.

When loading your refrigerator always allow some space between articles so the cold air can circulate properly. Before traveling make sure all lids are securely on containers.

Make absolutely sure the refrigerator door is latched. It's no fun to clean up a mixture of eggs, jelly and left-over baked beans after a long day's drive.

When storing the trailer and the refrigerator is turned off, it is a good idea to leave the door partially open so air can circulate.

FAULT TRACING

The refrigerator does not freeze satisfactorily.

CAUSES AND REMEDIES:

- A. Jet orifice clogged. Unscrew jet and blow clear or wash in alcohol. Do not use wire or pin to clean orifice.
- B. Check the leveling of the refrigerator.
- C. Flame has gone out. Remedy: 1) Gas in bottle is used up - refill. 2) Feeler point of the flame failure safety device is not heated enough by flame - check against Fig. 2 or 3. 3) Clogged by-pass screw - Clean or exchange it.
- D. Air circulation around cooling unit is restricted. Be sure that refrigerator is properly ventilated.
- E. The evaporator is heavily coated with frost. Defrost.
- F. Flue baffle not inserted into the central tube of the cooling unit.
- G. The thermostat is incorrectly used. See paragraph on thermostat. In hot weather the setting should be one or two numbers "colder" than usual.
- H. Gause in burner head clogged. Clean.
- I. Burner damaged. Replace.
- J. Burner may be dislocated. Relocate.
- K. Wrong gas pressure at the burner. Have pressure checked at burner and at gas bottle. Pressure at burner must not fall below 11" W.G. when thermostat is set on MAX.

FLAME FAILURE SAFETY DEVICE (FIG. 3)

The feeler of the thermocouple shall reach in over two slots of the burner. To replace the thermocouple proceed as follows:

1. Remove the plastic cover 22 (Fig. 5).
2. Unscrew plug 20 and pull thermocouple straight out.
3. Remove spring 21.
4. Pull out thermocouple sideways from burner housing.
5. Bend the new thermocouple to the same shape as the long one.
6. Reassemble in reverse order. Check that feeler has been correctly refitted in relation to burner. See Fig. 3.
7. Mount plug 20, taking care not to damage the threaded hole in the aluminum cap of the housing. The plug must be properly tightened to the valve housing to ensure good contact between the thermocouple and the magnetic coil within the housing.

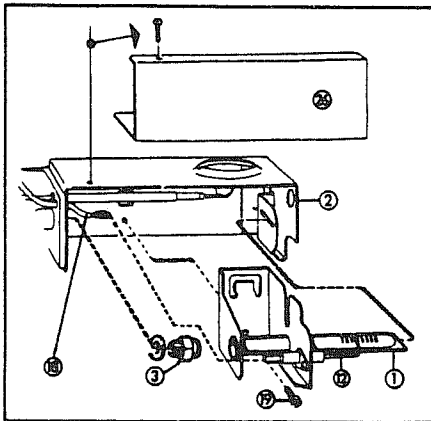

Fig. 2

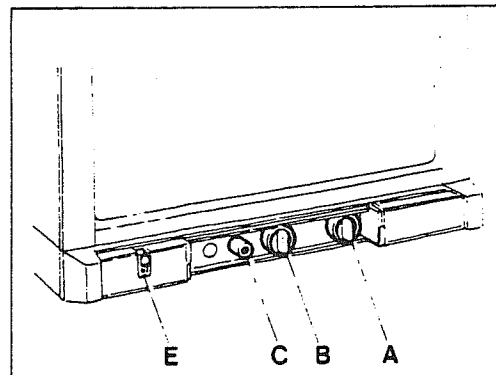

Fig. 4b.

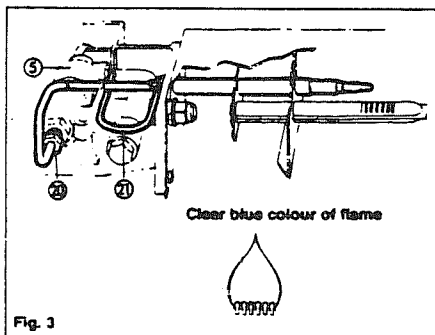

Fig. 3

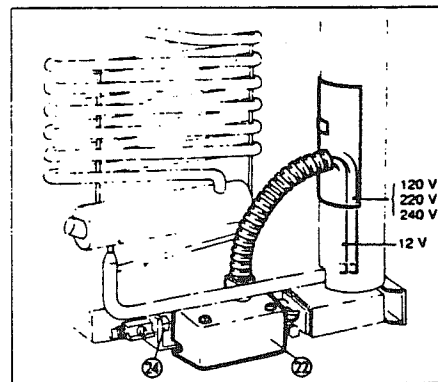
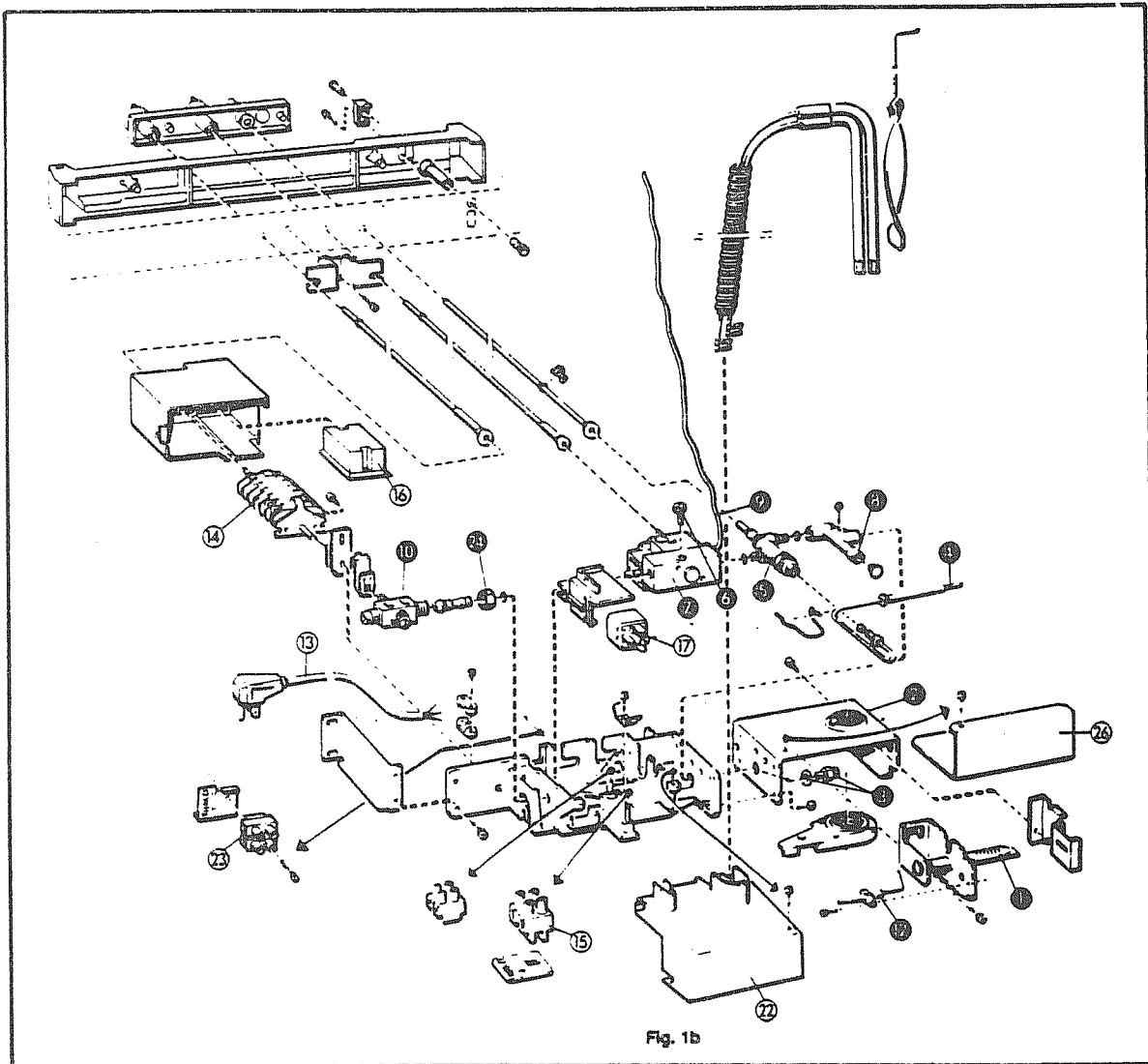

Fig. 5

REFRIGERATORS WITH AUTOMATIC IGNITION



Gas equipment parts

1. Burner tube
2. Burner Housing
3. Burner jet
4. Feeler point (thermocouple)
5. Flame failure safety device
6. Bypass screw
7. Gas/Electrical thermostat
8. Pressure test gauge conn.
9. Capillary tube for thermostat
10. Shut-off valve
11. Piezo igniter (lighter)
12. Electrode
19. Burner fixing screw
24. Hexagon nut
26. Cover plate

Electric equipment parts

13. Flexible cord
14. Change-over switch
15. Terminal block, 12 V DC
16. Reigniter
17. Relay
18. Lighter cable
22. Cover
23. Terminal block, 12 V DC
on certain models only

ELECTRIC EQUIPMENT

Cartridge Heater

The refrigerator is equipped also for electric operation. Most models are equipped for both 120 Volts AC and 12 Volts DC operation.

The heat necessary for the operation of an absorption type cooling unit is supplied by an electric cartridge heater mounted in a pocket of the boiler system.

To replace the heater, first of course, check that the wall plug is disconnected. If the refrigerator is equipped also for 12 volts DC operation make sure that the 12 V leads are disconnected. Then proceed as follows:

1. Remove the plastic cover (22) of the main control structure by loosening the two screws.
2. Disconnect the heater leads.
3. Pull off the metal hose.
4. With a pair of pliers unfold the lug holding the lid of the boiler casing and open the lid.
5. Remove some insulation wool so that the heater is accessible.
6. Turn and lift the heater out of its pocket.
7. Fit the new heater into the pocket and pull on the hose around the leads.
8. Connect the leads and put on the plastic cover.
9. Reset the insulation and close the lid of the boiler casing.

WARNING: If the refrigerator is used intermittently it should be checked at least once a year. It is important to keep the appliance area clear and free from combustible materials, gasoline and other flammable vapors and liquids. Check the venting system. The flow of combustion and ventilating air must not be obstructed. Check the flue baffle that it is clean and reasonably free from soot. Heavy soot formation indicates improper functioning of the burner. Clean baffle and flue. Further, clean cooling unit and floor under refrigerator. The entire gas installation should be checked for leaks at intervals. Test all pipe connections with soapy water, not with an open flame.

NOTE: Any service of the gas controls, with exception for the above mentioned replacement, maintenance and cleaning operations must be performed by an authorized service center only.

ODORS FROM FUMES

CAUSES AND REMEDIES

- A. The flame touches side of the boiler due to dislocation of the burner. Relocate. Burner dislocation may also cause smoke and discoloring of walls and ceiling.
- B. Burner damaged. Replace.
- C. The flame touches flue baffle. Remedy: 1) Burner damaged, Replace. 2) Flue baffle too low. Correct the position of the baffle.
- D. The flue tube is dirty. Clean flue as follows: Cover burner and jet. Remove flue top and baffle. Clean flue with special flue brush. Clean baffle before putting back in place.

All the above instructions are to be followed closely. The refrigerator is quality-guaranteed. However, we are not responsible for any failures caused by improper adjustments and unfavorable installation conditions. Contact service point or distributor service department for assistance.

TO CHANGE THE DOOR OPENING FROM LEFT TO RIGHT OR VICE VERSA

Open the door and unscrew the two screws holding the top front cover. The screws are accessible from beneath. Remove the top hinge pin and lift out the door. The lower pin for the refrigerator door should be shifted to the opposite side.

The door can then be remounted. Before the top front cover is refitted check that the door closes easily and that the gasket seals well on all sides.

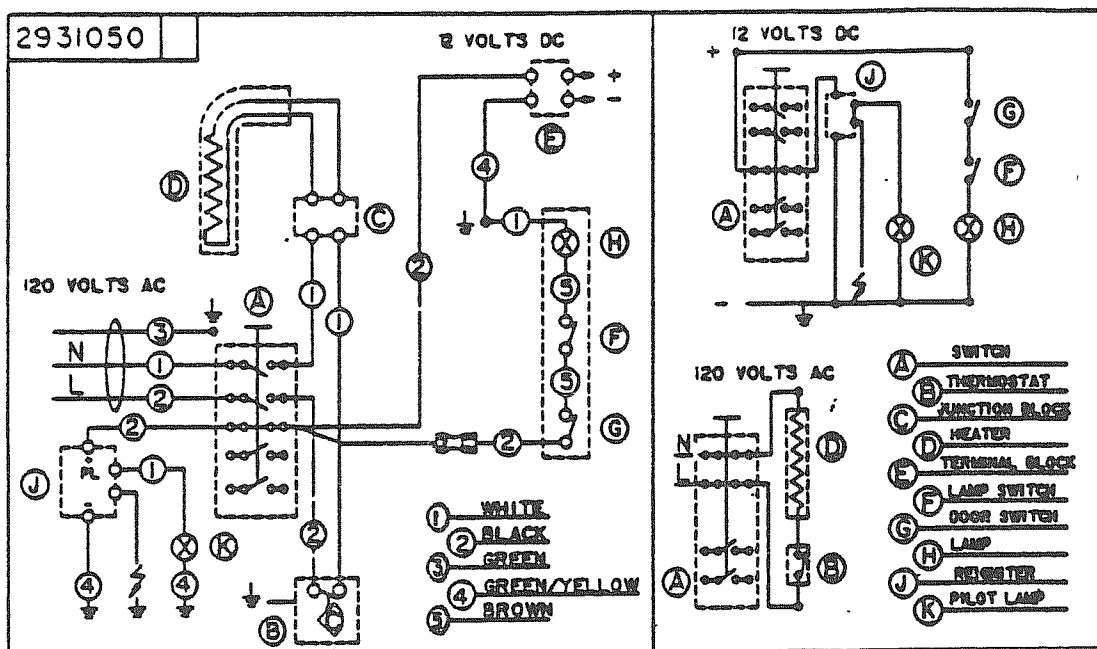

REFRIGERATOR PANEL

1. Reaching in through the exterior access door remove two large screws attaching the refrigerator to support base.
2. Turn gas off at LP bottles.
3. Remove gas line at valve.

CAUTION: Be sure to support valve with one wrench while loosening flare nut with another.

4. Mark and disconnect wires.
5. From inside coach remove masking plugs and screws around door jamb.
6. Cover floor and slide refrigerator out.

WARNING: Check gas connection with soap solution after reinstalling refrigerator.

REFRIGERATOR DOOR ASSEMBLY (RM2801)

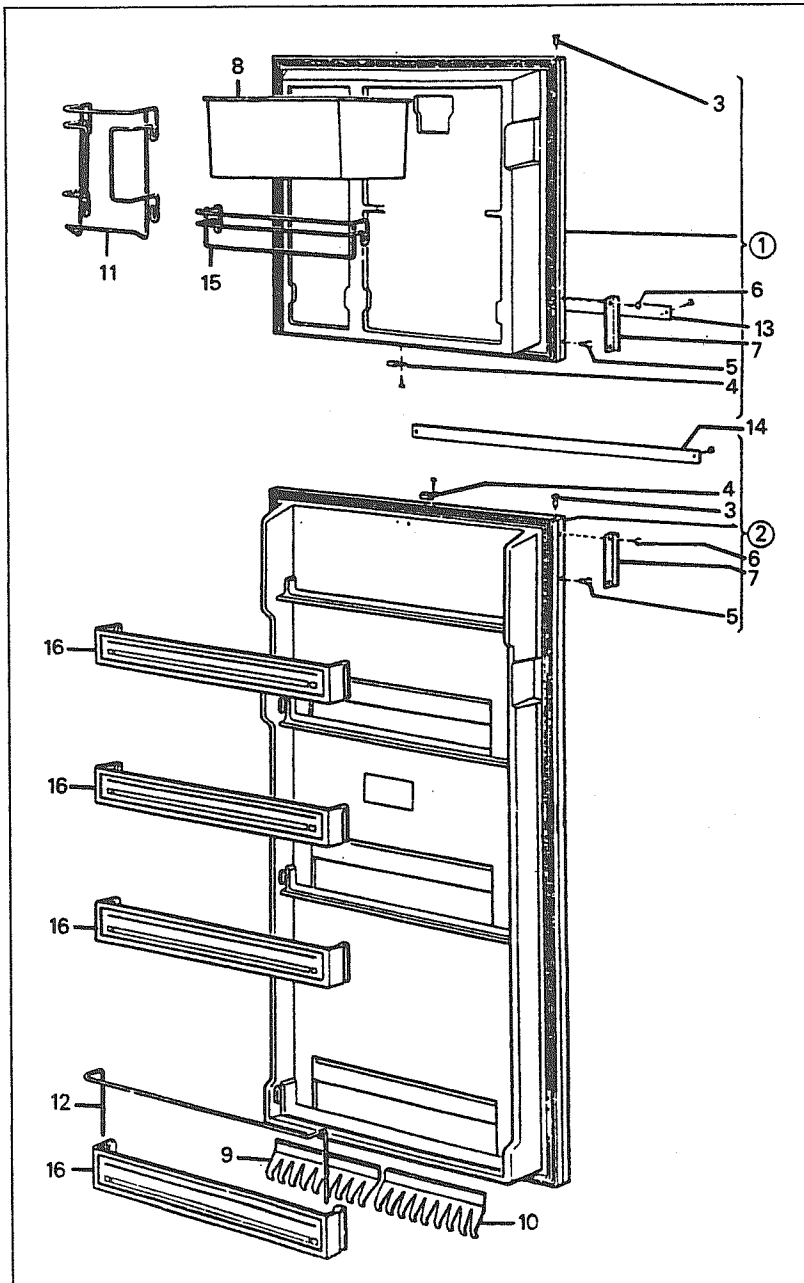

1. Door Upper, w/o shelves
2. Door Lower w/o shelves
3. Bushing
4. Catch Retainer
5. Plug, Grey
6. Screw
7. Handle
8. Box
9. Bottle Holder 7"
10. Bottle Holder 8"
11. Basket
12. Rack
13. Decoration strip
14. Decoration strip
15. Wire shelf
16. Door shelf

PARTS DESCRIPTION FOR PRECEDING PAGE

1. Hinge, upper
2. Cooling flange
3. Shelf 12"
4. Plastic shelf, 11"
5. Shelf, cpl. D approx 7"
6. Shelf, D approx. 12"
7. Latch grey/brown
8. Ice tray
9. Shelf lock, outer
10. Shelf lock, inner
11. Thermostat retainer
12. Latch housing, grey/brown
13. Crisper
14. Front decoration
15. Hinge pin, upper
16. Hinge
17. Covering plate
18. Hinge pain
19. Switch
20. Light 12V cpl.
21. Lamp 12V
22. Switch
23. Push button
24. Lamp retainer
25. Knob, thermostat "OFF-MAX"
26. Knob selector "GAS-OFF-ELEC"
27. Spirit level
28. Hinge, RH
29. Hinge, LH
30. Hinge pin
31. Panel, grey/brown
32. Base front, grey/brown
33. Drip tray
34. Plug
35. Cover, light
36. Shade, lamp
37. Pin
38. Lamp socket, grey/brown
39. Pilot lamp
40. Sealing sleeve
41. Plug, grey/brown
42. Protecting sleeve
43. Sealing plate
44. Cover
45. Clamp
46. Cover

PARTS DESCRIPTION COOLING UNIT (RM2801)

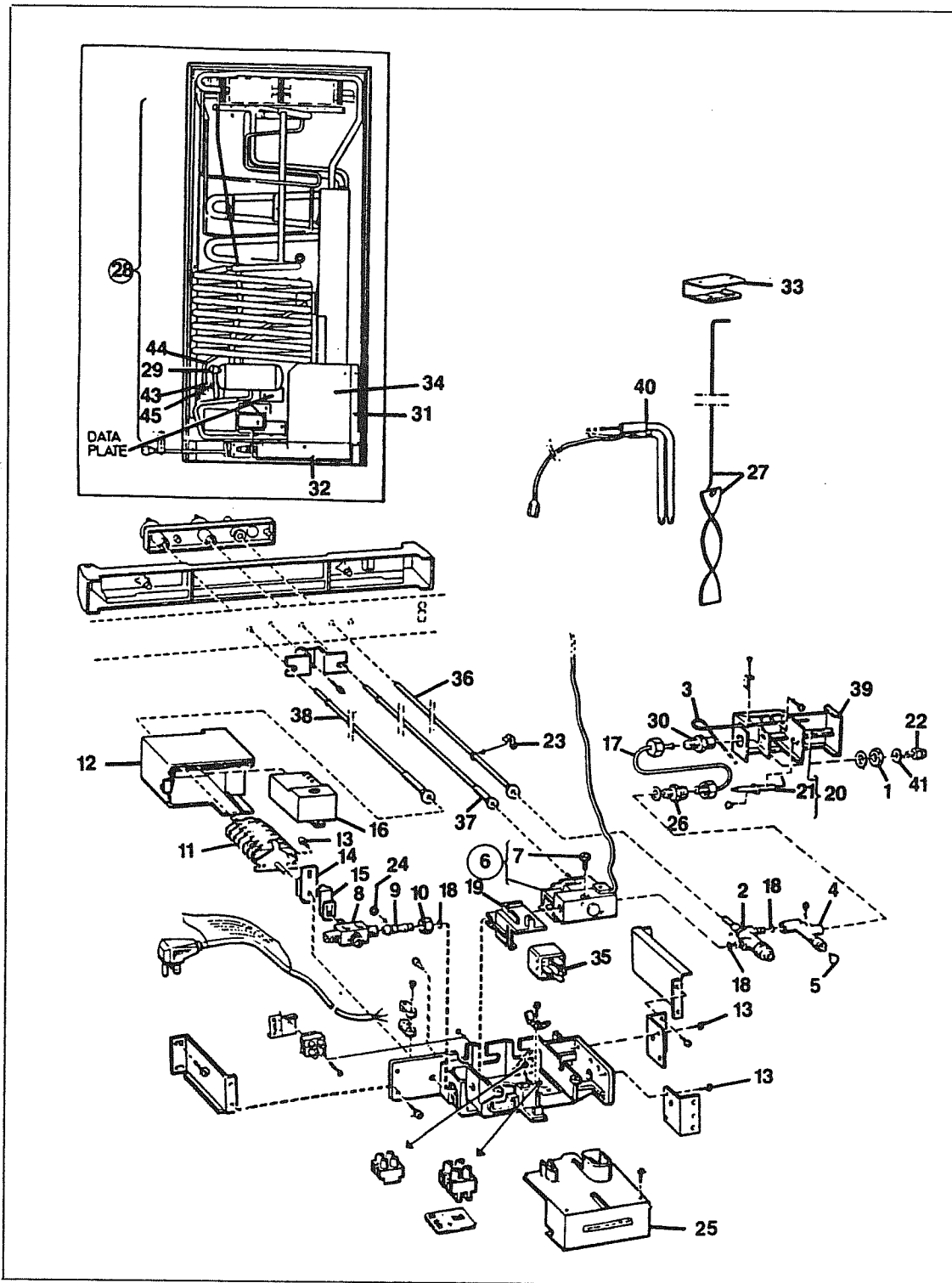

PARTS DESCRIPTION FOR PRECEDING PAGE

1. Nut, F/orifice
2. Safety valve
3. Thermocouple element
4. Coupling
5. Plug screw
6. Thermostat
7. Bypass screw, S14
8. Cut off valve
9. Nipple
10. Nut
11. Switch
12. Cover
13. Screw
14. Spring
15. Spring clip
16. Reigniter
17. Gas tube
18. Sealing ring
19. Snap catch
20. Burner
21. Electrode
22. Burner jet
23. Clip
24. Retaining ring
25. Cover
26. Nipple
27. Flue baffle
28. Cooling unit
29. Filling cap
30. Nipple
31. Protection plate
32. Drip plate
33. Flue top
34. Protection plate
35. Relay for 12/120V
36. Push rod
37. Shaft, thermostat
38. Shaft, switch
39. Burner housing
40. Heater
41. Washer, orifice
42. Evaporation tray
43. Spillway
44. Draining hose
45. Clamp

WATER HEATER

Manufacturer: Atwood Vacuum Machine Company
1400 E. Eddy Avenue
Rockford, IL 61101
Phone: 815-877-7461

The standard water heater in your Land Yacht requires only LP fuel to be operational. The optional electronic ignition model will require 12 volt power as well as the LP fuel to operate. Never light the water heater unless you are sure it is filled with water.

Complete operating instructions of the water heater installed in your Land Yacht is included in the Owner's Packet. Basic trouble shooting procedures can be obtained from the manufacturer.

If service is ever required the standard model components will be familiar to any LP appliance repairman. Many of the parts will readily exchange with parts used on home type water heaters.

The electronic ignition model is newer, and only an authorized Atwood or Land Yacht service location can be recommended.

The water heaters have a much smaller capacity than those in your home; but, the recovery rate is fast. Planning the use of hot water so there is just a little time in between will mean there is plenty for all.

ADJUSTMENTS

Your water heater may have either a Robertshaw or ITT control. Pilot adjustments for both are shown.

ROBERTSHAW UNITROL

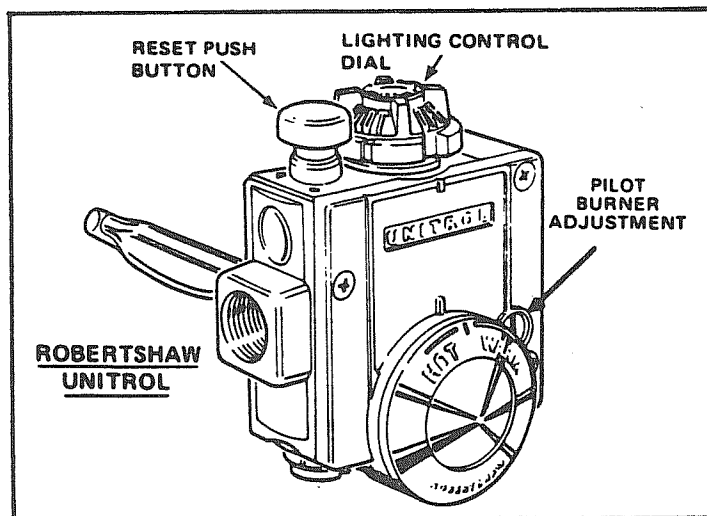

PILOT BURNER ADJUSTMENT

1. Remove cap
2. Turn out (counterclockwise) to decrease - Turn in (clockwise) to increase.
3. Flame size same as shown for ITT control.
4. Replace cap.

ITT GENERAL CONTROL

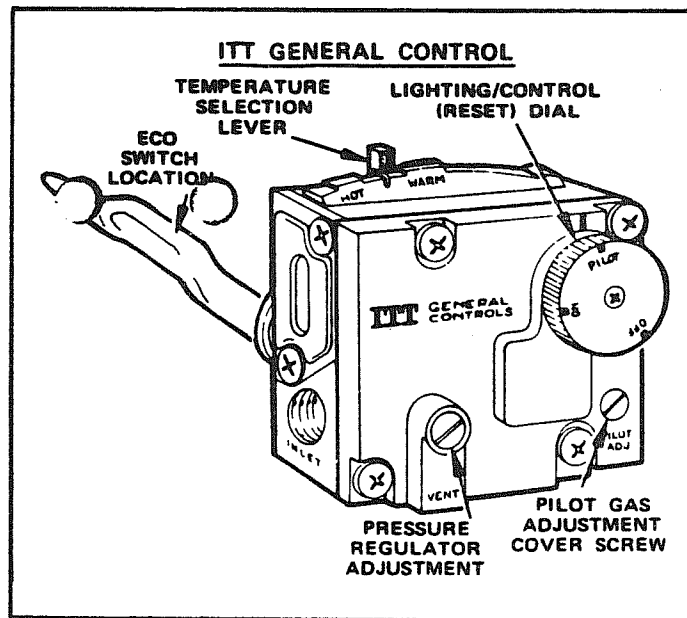

PILOT BURNER ADJUSTMENT

Pilot adjustment located directly below pilot on/off knob.

1. Remove pilot gas adjustment cover screw.
2. Adjust pilot key directly inside to provide proper size flame. (1/2" high or until a slight yellow tip appears in pilot flame.)
3. Replace pilot gas adjustment cover screw.

ADJUSTMENT

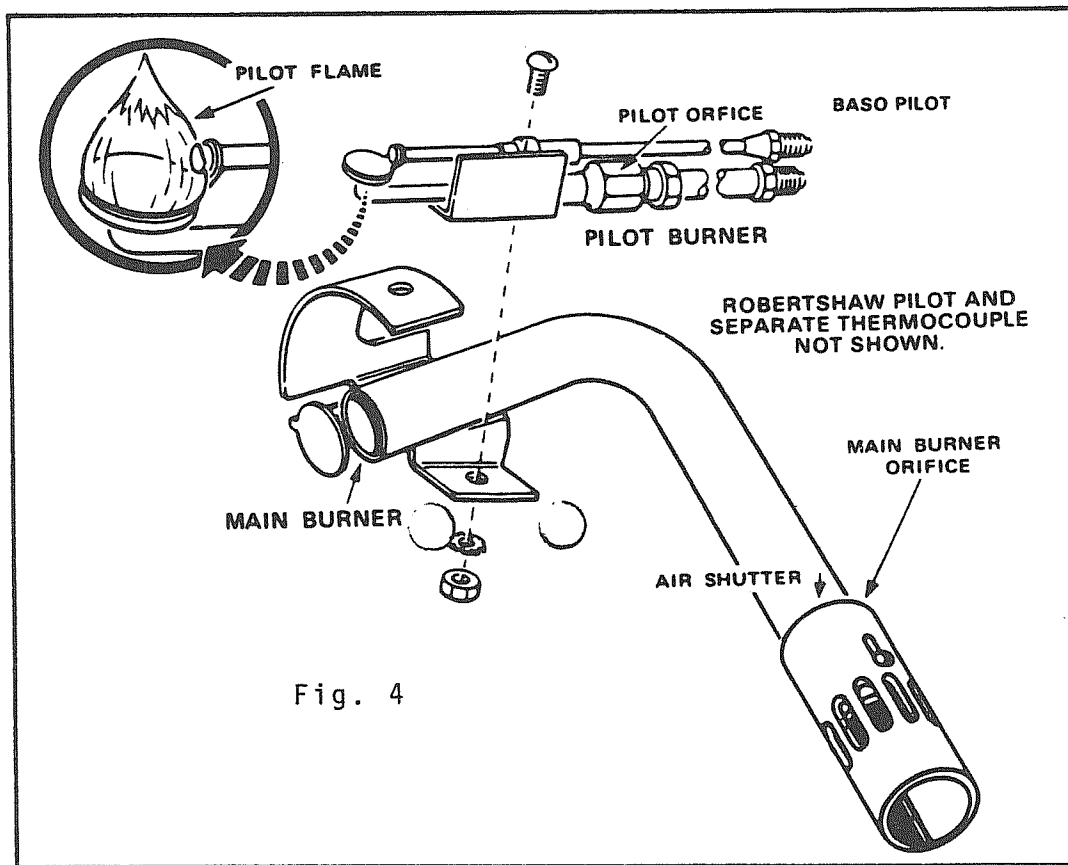

BURNER ADJUSTMENT: Slide main burner air shutter to the right enough for yellow tip to appear in flame, then slowly slide shutter to the left until yellow tip disappears and lock with set screw.

SPECIAL CAUTION: All gas appliances must be shut off when refueling. This also includes pilot lights.

MAIN BURNER FLAME

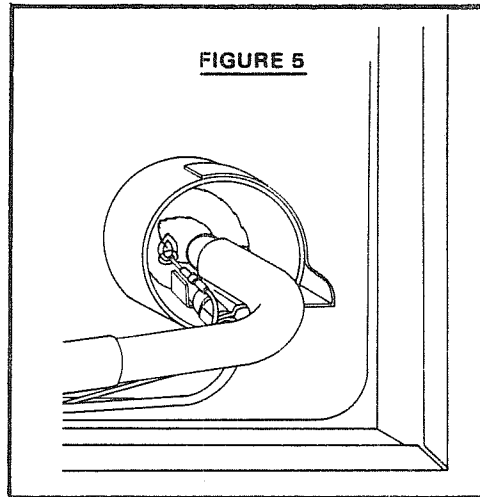

Suggested Maintenance

1. Keep the control compartment clean and free of combustible material and flammable liquids.
2. Keep the vent and combustion air grill clear of any obstructions.
3. Compare main (Fig. 5) and pilot burner (Fig. 4) flame with illustrations above periodically.

No valve is to be placed between the relief valve and the tank. If a discharge line is used no reducing coupling or other restriction can be used. Do not plug the relief valve under any circumstances.

ACCESS COVER ASSEMBLY INSTRUCTIONS

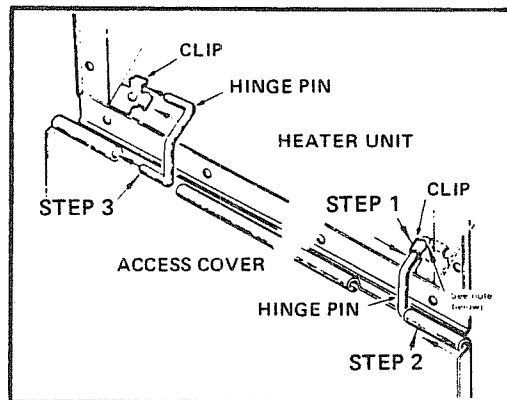

1. Snap hinge pin into clip.
2. Slide cover onto hinge pin.
3. Snap other hinge pin into clip and cover at the same time.

NOTE: To remove hinge pin, support access cover and apply force to corner of hing pin as shown above.

WIRING SCHEMATIC/DIAGRAM

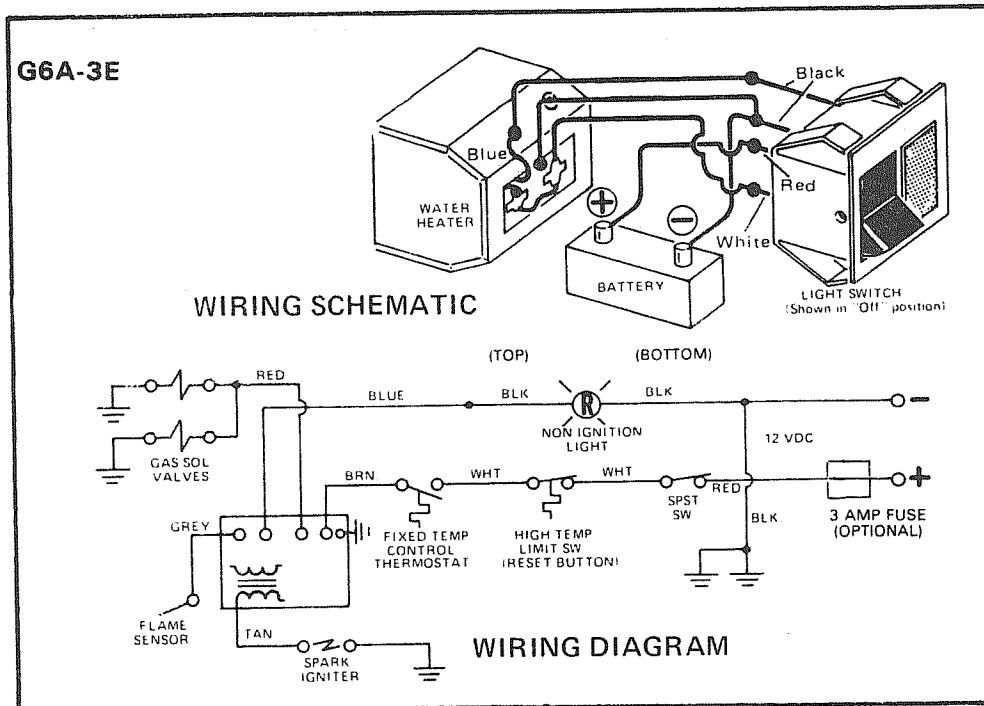

REMOVAL

In order to remove the water heater, access must be gained to the water lines on the back of the heater. The carpeted panel next to the panel is only held in with about three screws - two in the top and one in the bottom corner. They can be difficult to see buried in the nap of the carpet, but if you feel with your fingertips you won't have any problem finding them. Once you have access to the lines the removal is basic:

1. Turn off LP gas at the bottles.
2. Disconnect city water or turn off water pump.
3. Remove drain plug in the face of the heater and open a faucet so water will drain.
4. Mark and disconnect wires if it has electronic ignition.
5. Remove perimeter screws around the face of the heater.
6. Use a putty knife or similar tool to break the seal between the water and the side of the trailer. Be careful not to damage paint.
7. After heater has drained remove water lines next to toilet.
8. Remove gas line.
9. Work the heater side to side as you are pulling out.

WARNING: Be sure to check the gas line connection with soapy water when replacing.

WATER HEATER PARTS DIAGRAM

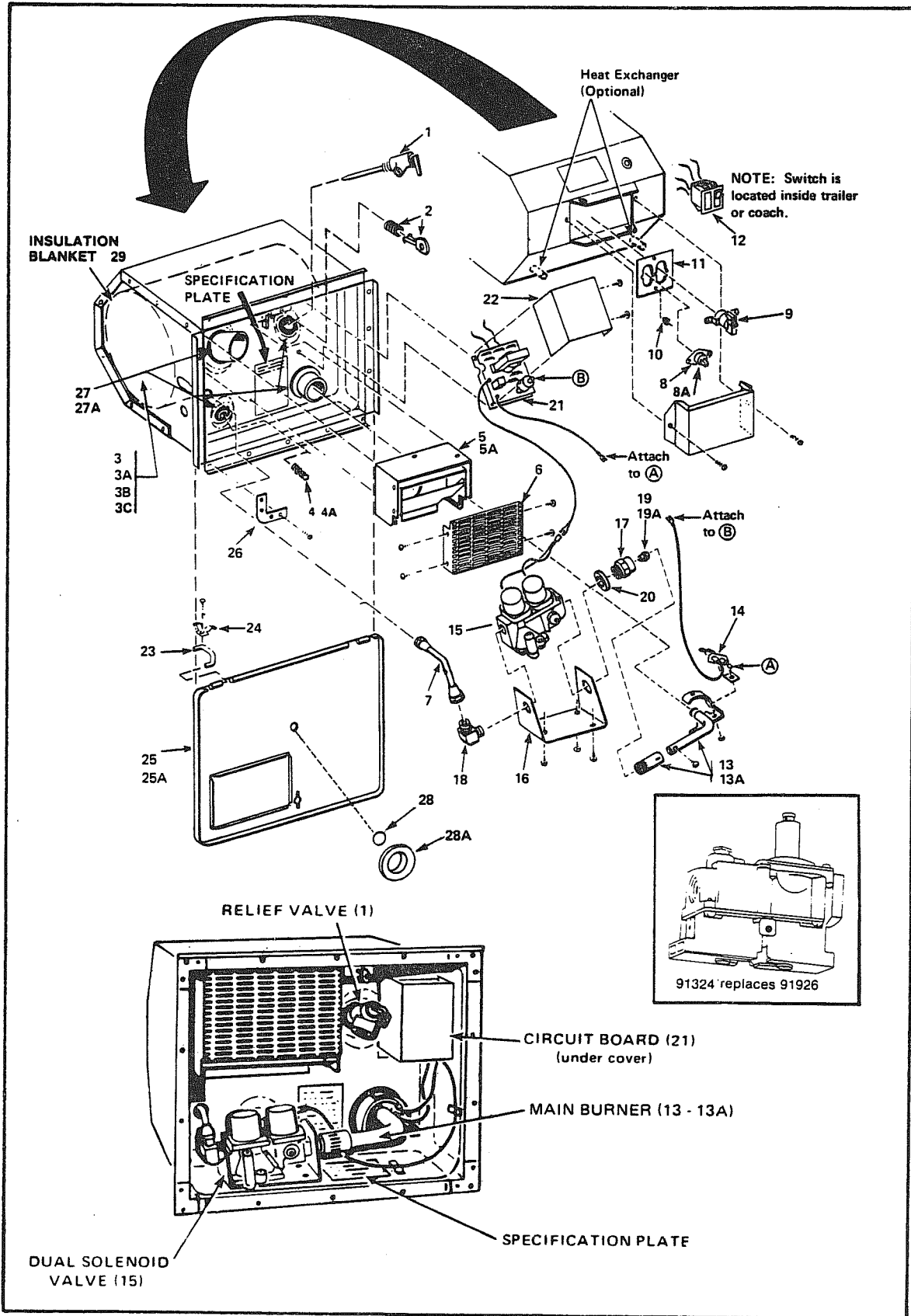

PARTS DESCRIPTION FOR PRECEDING PAGE

1. Relief valve 1/2" fitting
2. Cam-loc fastener
3. Inner tank
4. Drain plug
5. Flue box
6. Exhaust grille
7. Gas inlet tube
8. Thermostat 12 V DC
9. ECO switch
10. Loc-nut
11. Control retainer plate
12. Switch package
13. Main burner
14. Spark probe assembly
15. Gas valve
16. Valve bracket
17. Orifice holder
18. Elbow fitting
19. Main burner orifice
20. Washer gasket
21. Circuit board
22. Circuit board cover
23. Hinge pin
24. Hinge clip
25. Access cover
26. Corner brackets (set of 4)
27. Standard 6 gal gasket kit
28. Gasket for sight window
29. Insulation blanket

SPECIFICATIONS

	<u>29 ft.</u>	<u>32 ft.</u>	<u>33 ft.</u>	<u>35 ft.</u>
Height with air conditioner	116"	116"	116"	116"
Height without air conditioner	108"	108"	108"	108"
Overall length	29' 4"	32' 2"	33' 3"	35'
Gross Vehicle Weight Rating (GVWR)	7,300 lbs.	7,300 lbs.	8,500 lbs.	8,900 lbs.
Gross Axle Weight Rating (GAWR)	7,000 lbs.	7,000 lbs.	8,000 lbs.	8,400 lbs.
Dry Weight (No Options)	5,400 lbs.	5,600 lbs.	6,100 lbs.	6,300 lbs.
Hitch Weight	600 lbs.	600 lbs.	700 lbs.	700 lbs.
* Hitch Ball Height (Estimate)	18"	18"	18"	18"
Brakes	10"x2¼"	10"x2¼"	12"x2"	10"x2¼"
Tires, Bias Belted	H78 x 15	H78 x 15	H78 x 15	H78 x 15
Alignment:	Toe In	0-1/8"	0-1/8"	0-1/8"
	Camber	0-1½+	0-½+	0-½+
Converter	45 amp	45 amp	45 amp	45 amp
Capacities:	Fresh Water	50 gal.	50 gal.	50 gal.
	Grey Water (Drain)	35 gal.	35 gal.	35 gal.
	Black Water (Waste)	30 gal.	30 gal.	30 gal.

NOTE: All weights and measurements were made on prototype vehicles. Your production trailer may vary slightly.

* To obtain your exact hitch ball height load vehicle as you would when towing, level front to back, then measure to the top of the hitch ball socket.

INDEX

- Access Doors.....D-2
- Accessories.....B-17
- Air Conditioner.....H-1
- Antenna.....G-18
- Axles.....D-9

- Backing.....B-15
- Bathroom.....E-3, F-40
- Battery.....E-4, G-8
- Bearing.....D-9
- Beds.....E-3
- Bottles, LP.....C-5, D-2, F-1
- Brakes.....B-2, B-13, D-12
- Break-Away Switch.....B-2
- Bulbs.....A-8, G-17

- Camping.....C-1
- Carpet.....E-2
- Capacities.....I
- Cargo.....B-5, D-2
- Caution.....Introduction
- Certification Label.....B-5
- Chassis.....D-4
- Check List.....B-16
- City Water Hookup.....C-4, F-17
- Cleaning.....E-2
- Circuit Breakers.....G-1, G-7
- Condensation.....C-5
- Convertor.....G-5
- Connector.....
 - 7-Way.....B-4
 - 110 Volt.....G-1
- Couch.....E-3
- Coupler.....D-4
- Curtains.....E-1

- Dead Bolt.....D-1
- Dinette.....E-4
- Doors.....
 - Main.....D-1
 - Screen.....D-2
 - Storage.....D-2
- Drain Valves.....F-25
- Drainage.....C-4, F-37
- Drapes.....E-1
- Dump Valves.....F-33

- Electrical.....G
 - 12 Volt.....B-4, G-7, G-12
 - 110 Volt.....G-3
 - Fuses.....A-8, G-7
 - Circuit Breakers.....G-1, G-7
 - Diagrams.....
 -B-4, G-3, G-5, G-13, G-15
 - Power Cord.....G-1
 - 7-Way Cable.....B-4
 - Trouble Shooting.....G-10
- Emergency Escape Window.....E-7
- Equipment.....B-17
- Exhaust Fans.....E-12
- Exterior Maintenance.....D-1

- Factory Service.....A-5
- Fans.....E-12
- Faucets.....F-18
- Filter, Water.....F-8, F-16
- Fire Extinguisher.....C-1, E-7
- Flat Tire.....D-7
- Furnace.....H-11
- Fuses.....A-8, G-7

- Galley.....E-2
- Gas, LPG.....C-5, D-2, F-1
- GAWR.....B-5, I-1
- Grey Tank (Aux).....F-25, F-33
- Ground Fault Interrupter.....G-1
- Grounding.....G-1
- GVWR.....B-5, I-1

- Hitch.....B-8
- Hitch Ball.....B-9, B-10
- Hitching Up.....B-8
- Hitch Weight.....B-7
- Holding Tanks.....F-33

- Inflation, Tires.....D-7
- Interior.....E

- Jacks.....
 - Front.....B-11, D-5
 - Stabilizing.....C-3
 - Tire Changing.....C-3, D-7

Latches.....	D-4	Table.....	E-4
Lavatory.....	E-3	Taillights.....	B-4, G-16
Leveling.....	C-3	Tires.....	D-7
Lights.....	G-17	Tongue Latch.....	B-9, D-4
Linoleum.....	E-2	Tongue Weight.....	B-7
Loading.....	B-5, D-2	Toilet.....	F-40
Locks.....	A-6	Towing.....	B-12
LP Gas.....	C-5, D-2	Tow Car.....	B-1
		TV Antenna.....	G-18
Maintenance Parts.....	A-8	Upholstery.....	E-1
Maintenance Record.....	A-9	Ventilation.....	C-5
Maintenance Schedule.....	A-6	Vents.....	E-9, E-12
Mircowave.....	G-2	Warranty.....	A-1
Monitor Panel.....	G-21	Warning.....	Introduction
Oven.....	H-27	Washing.....	D-1
Overnight Stop.....	C-2	Water.....	F-8, F-30
		Heater.....	H-52
Paneling.....	E-3	Filter.....	F-15
Parking.....	C-2	Pump.....	F-8, F-10
Passing.....	B-12	Inlet.....	C-4, F-17
Plumbing.....	F-1	Drainage.....	F-25, F-33
Power Cord.....	C-4, G-1	Sanatizing.....	F-8
Power Jack.....	D-5	By Pass.....	F-27
Range.....	H-27	Waxing.....	D-1
Range Exhaust.....	E-12	Weight.....	B-6, I-1
Refrigerator.....	H-40	Weight Distribution, Hitch..	B-8
Regulator, LP.....	F-1	Wheel.....	
Roof Vents.....	E-12	Torque.....	D-7
Rotation, Tire.....	D-8	Alignment.....	D-9
		Bearing.....	D-9
Safety Chains.....	B-10	Windows.....	E-7
Screens.....	E-10	Winter Trailering.....	C-5
Service.....	A-5	Winterizing.....	F-28
Seven-Way Connector.....	B-4	Wiring.....	G
Sewer Hose.....	F-33	12 Volt.....	B-4, E-5, G-17
Shower.....	F-19, F-25	110 Volt.....	G-3
Sink.....	E-2	7-Way Connector.....	B-4, G-15
Smoke Alarm.....	A-6, E-6	Woodwork.....	E-3
Spare Tire.....	D-7		
Specifications.....	I		
Stabilizing.....	C-3		
Step.....	D-3		
Storage.....	D-2, E-4, F-28		
Stove.....	H-27		
Suspension.....	D-8		

