

# *Excella* 500



1974 Owners Manual

An Airstream travel trailer offers you the ultimate in travel luxury and mobility. This owner's manual is your key to carefree travel fun. It contains information necessary to avoid problems. Consult it when you have a question about your new Airstream. It has been designed to aid you in knowing your trailer better. All information, illustrations and specifications contained in this literature are based on the latest product information available at the time of publication approval. The right is reserved to make changes at any time without notice. Should you trade or sell your Airstream, please leave the manual with the trailer. Go Airstream and make this your year for carefree vacations.

# Contents

Wally Byam Caravans/Clubs .....	2
Warranty and Service .....	4
Service Centers .....	6
Wally Byam Stores .....	10
Tow Car Equipment .....	11
Chassis .....	12
Load Chart .....	14
Tires .....	15
Hitching Up .....	16
Towing Tips .....	18
Overnight Stop .....	21
Extended Stay .....	22
Winter Airstreaming .....	24
Storage and Winterizing .....	25
Exterior .....	28
Floor Plans .....	30
Interior .....	32
L.P.G. System .....	40
Refrigerator .....	41
Micro Wave Oven .....	43
Range/Oven .....	44
Furnace .....	46
Water Heater .....	48
Water System .....	49
Drain/Waste/Vent Systems .....	52
Electrical System .....	55
Battery .....	57
Battery Charger .....	58
Electrical Trouble Shooting .....	63
Specifications .....	66
Pre Travel Check List .....	68
Lubrication and Maintenance .....	70
Index .....	72

# Wally Byam Caravans/Clubs

When you bought your Airstream, you bought a whole new way of life. Airstream owners enjoy endless opportunities for friendship, fun and adventure. You may join every Airstream Wally Byam Caravan and Airstream Company Rally. We arrange for such rallies each year: one in the North West, South West, North East and South East. You also become eligible to join the Wally Byam Caravan Club International, the largest single make trailer club in the world. The WBCCI is made up of 22,959 family memberships and 131 local chapters or units throughout the United States, Canada and Mexico. They meet at monthly rallies, or where weather conditions prevent year round rallies, Caravanners come together for pot luck dinners to plan events for the good seasons.

Since the first Wally Byam Caravan in 1951, 89 Airstream Caravans have gone to most parts of the world. Caravans to Canada and Mexico are now so popular that there are eight each year. Many a lifelong friendship was started on these trips. Old-timers and new owners share experiences and find a new kind of fellowship, and there is no better way to learn to use your Airstream. Caravanners enjoy many advantages: the security of traveling in a group, planned entertainment and exceptional sightseeing opportunities. The prestige and good will established over many years by our Caravans adds further benefit to Caravanner membership.



The "Caravanner" and the "Blue Beret" are the official Caravan Club publications. The bi-monthly "Caravanner" is for general distribution to owners and prospective buyers, while the monthly "Blue Beret" is for WBCCI members only.

Several months before a Caravan rolls, the "Caravanner" and the "Blue Beret" publish a description and a registration coupon. Everyone who registers receives a detailed bulletin with complete information on the caravan. When going abroad, all official matters such as insurance, tourist cards and border crossing formalities are handled for you by the Caravan staff.

On every Airstream Caravan, the route is carefully planned, and a day by day itinerary, including mail stops, is given to all Caravan-

ners in advance. Our staff also makes all the arrangements for parking, entertainment, tours, etc. well ahead of the starting date. Airstream Caravan Programs always take caravanners of all ages into account. Airstream provides the Caravan Staff: a leader, a recreation director, a service representative and an advance representative. This staff is backed by committees composed of interested Caravan members who assist in the day-to-day operations.

Wally Byam, pioneer trailer traveler, and founder of the Airstream Company, was born on July Fourth and the first International Rally was in the form of a huge birthday party for him at Bull Shoals, Arkansas. It was patterned after the International Rallies in Europe which Wally and his wife Stella had attended for many years. Everyone enjoyed





this first big rally so much that the club decided to make it an annual event. Since then, International Rallies have grown and grown. Some 3,500 Airstream Travel Trailer-families recently gathered at Bozeman, Montana for the 1973 International Rally.

Only Wally Byam Caravanners and WBCCI members are entitled to have an official **Trailer Number** and be listed in the **Annual Directory**. The Annual Directory contains a schedule of all major rallies and Airstream Wally Byam Caravans for the year, and announces the activities of the Ham Radio, C.B. Radio, Square Dance and the many other WBCCI special interest clubs.

Along with the fun, Airstream owners recognize the need for better legislation, more and better overnight parking facilities, more sani-

tary stations and other travel conveniences.

They are alert to adverse bills governing travel trailers and have achieved much through the actions of the strong WBCCI National Legislative Committee.

The Way of Life Department, of the Airstream Company dedicates its full time staff to improving the owners' fun and makes use of all the information and experience gained by owners over the years to help develop even better Airstreams.

**Become part of the Airstream Way of Life.** Join our WBCCI activities and we believe you will enrich your life. Owners join through a local unit of WBCCI. All operate autonomously, elect their own officers and fix their own dues. Annual International dues are paid

with the unit dues at the time of application. These are at present: International dues, \$5.00 per trailer and unit dues from \$1 to \$6. If you are interested, please write to the following address and we will forward your letter to the unit nearest you:

WBCCI Headquarters Office  
15939 Piuma Avenue  
Cerritos, California 90701

# Warranty and Service

Airstream offers the most complete and explicit warranty in the industry. Your valuable warranty covers every item in your trailer (except tires and battery) against failures resulting from defects in either material or workmanship for two years from date of purchase as the original owner.

Adjustments to appliances, gas pressure or other normal service and maintenance requirements are not a part of the warranty. Fading or deterioration of upholstery, curtains or other material due to sunlight, normal use or exposure is not warrantable. Your warranty is designed to cover defects in material and workmanship.

Your tires and battery are warrantied by their respective manufacturers and will be handled by their service centers according to the terms of their written policy.

Axle alignment and wheel balancing was checked on your Airstream before it left the factory. The axles will not need realignment unless your tires receive a severe blow, such as road hazards, curbs, etc. Your tires and wheels will require re-balancing each time they are removed or rotated. All balancing or alignment charges will be a customer's obligation.

**Please read the facsimile warranty carefully. As soon as the factory has received your**

**signed check-out and acceptance sheet, a formal warranty is issued to you, together with an owner's identification card. As soon as you receive your warranty, please attach it over the facsimile for safekeeping. In order to qualify for service without charge under the Airstream Warranty Program, your owner's identification card or warranty must be presented to the service representative.**

**The Airstream Certified Performance Check-out, or C.P.C., is an exclusive Airstream program. Before leaving the factory, each and every vital part of an Airstream is tested for performance. Each test is signed and certified by an inspector. After the Airstream arrives on your dealer's lot, all of these vital parts and systems are again tested. When you take delivery of your new Airstream, a factory trained trailer expert personally gives you a complete check-out on the trailer.**

**C.P.C. does not stop here. After you have traveled with your Airstream for 1000 miles (or 60 days, whichever comes first) you can make an appointment with any one of the 190 Airstream dealers or service centers for still another check-out of your trailer. At that time, a specified list of performance checks on your trailer equipment will be conducted and any deficiencies you have experienced since taking delivery will be corrected. Give the C.P.C. card overleaf to the dealer when you take your Airstream for the 1000 mile check.**



Please contact your dealer if you need service. Major service under your Airstream Warranty is available through our nationwide network of factory trained specialists at Airstream Certified Dealer Service Centers listed on pages 6 — 9 of this manual. All centers operate on an appointment basis for the utmost efficiency. When you require service from the Airstream factory or a certified service center, please contact the service manager for an appointment, and kindly inform him if you are unable to keep the appointment date or wish to change it.

Airstream factory service may be arranged by contacting the service manager:

Airstream  
15939 Piuma Avenue  
Cerritos, California 90701  
(213) 860-4411

Airstream  
Jackson Center, Ohio 45334  
(513) 596-6129

# 1

## The Exclusive Caravanner Travel Trailer Insurance Plan

A complete comprehensive policy, including these five big bonus benefits at no additional cost:

- Collision coverage (low deductible)
- Theft coverage against personal effects
- Personal effects coverage against damage or loss by collision, etc.
- Vacation expense allowance
- Mexico travel coverage (90 days)

And, there are no other deductibles!

Already over 25,000 Airstream owners are benefiting from this program. Fast, efficient claim service, coast to coast. Underwritten by Central National Insurance Company of Omaha, with assets of over \$20 million. This program also includes complete protection against these losses: fire, lightning, explosion, windstorm, hail, landslide, flood, all accessories, vandalism, and many more perils commonly insured by comprehensive coverage.

# 2

## The New Airstream Owner's Association Accident Insurance Program

A big bonus benefit available only to Airstream owners.

This program includes 24-hour protection for accidental death or dismemberment — anywhere in the world, on or off the job; on business, on vacation — or at home PLUS double benefits while on a trip with your Airstream.

No medical statement is required and you will not be bothered by a

physical examination or investigation. But you must be an Airstream owner, under age 75. There are 4 specialized plans from which to choose. Here's an example of benefits:

Plan B-1 (Owner and Spouse). While at home plan pays \$20,000 accidental death and dismemberment and up to \$400 monthly "while in hospital" income (as a result of accident). Under the same B-1 plan, while on a trip in your Airstream, the accidental death benefit would increase to \$50,000 and the monthly in-hospital allowance would be \$1,000 (as a result of accident). Best of all, the annual premium for Plan B-1 is a low, low \$89.

For fast efficient service and answers to your specific questions, call (213) 385-7461.

Travel carefree. Fill out and mail the following request card today!

Please rush information on these exclusive Airstream money-saving programs:

- Caravanner Travel Trailer Insurance Plan
- Airstream Owner's Association Accident Insurance Program

Name \_\_\_\_\_

Address \_\_\_\_\_

City \_\_\_\_\_ State \_\_\_\_\_ Zip \_\_\_\_\_

**BUSINESS REPLY MAIL**

No postage necessary if mailed in the United States

**FIRST CLASS**  
Permit No. 36321  
Los Angeles, CA

Postage will be paid by

CARAVANNER INSURANCE, INC.

2411 West Third Street

Los Angeles, CA 90057

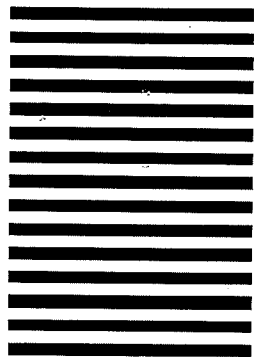

Please place your Registered Warranty over this Facsimile within the line, the folded edge on top. There is a glue strip on the back for this purpose.

A decorative horizontal bar with ornate circular end caps. The word "AIRSTREAM WARRANTY" is written in a stylized, serif font across the center of the bar.

## AIRSTREAM WARRANTY

For the lifetime of the Registered Warranty Holder, or so long as he continues as the original owner of the Airstream Travel Trailer, Airstream warrants the metal shell, frame, axle and axle assembly to and including spindle (excluding shock absorbers) to be free from defects in material and workmanship; all other component parts, including shock absorbers (excluding tires and batteries) are likewise warranted for a period of two years from the date of purchase. Any warranty defects will be corrected without cost upon return of the trailer, or defective part, to any Airstream factory or authorized Airstream service center.

*This warranty is in lieu of all other warranties of merchantability or fitness expressed or implied, there being no warranties which extend beyond the description on the face hereof and expressly excludes conditions resulting from normal wear, accident, abuse, exposure or overload.*

**AIRSTREAM**

Ohio factory: 177 West Church Street, Jackson Center, Ohio 45334  
California factory: 15939 Piuma Avenue, Cerritos, California 90701

A decorative horizontal bar with ornate circular end caps, identical to the header. The word "AIRSTREAM WARRANTY" is written in a stylized, serif font across the center of the bar.

## AIRSTREAM WARRANTY

# Service Centers

## ALABAMA

*Alabama Auto Carriage Company*  
P.O.Box 1695  
2359 West Fairview  
Montgomery, Alabama 36108

*Camper City*  
7320 First Avenue, North  
Birmingham, Alabama 35206

## ARKANSAS

*Fred & Jack Trailer Sales*  
10318 New Benton Highway (I-30W)  
Little Rock, Arkansas 72209

## ARIZONA

*Robert Crist & Company*  
2025 East Main Street  
Mesa, Arizona 85203

*Robert Crist & Company*  
8833 N. Black Canyon Hwy.  
Phoenix, Arizona 85021

*Gunn's Recreational Vehicles, Inc.*  
1912 Prince Road West  
Tucson, Arizona 85700

## CALIFORNIA

*Adventure Trailer Center*  
5810 S. Union Avenue  
Bakersfield, California 93307

*Bob Belknap Trailer Sales, Inc.*  
420 South Harbor Boulevard  
Santa Ana, California 92704

*Caswell's Vacation Vehicles*  
700 East Foothill Boulevard  
Pomona, California 91767

*Coastline Trailer Sales*  
303 North Ventura Avenue  
Ventura, California 93001

*Haller Trailer Sales*  
15711 S. Lakewood Blvd.  
Paramount, California 90723

*Holiday Trailer Sales*  
770 East Baseline  
San Bernardino, California 92410

*Nelson's RV Enterprises, Inc.*  
28001 Mission Blvd.  
Hayward, California 94544

*Pulmobile Trailer Sales*  
4563 San Fernando Road  
Glendale, California 91204

*Ralph's Trailer Sales & Supply*  
1025 East Main  
El Cajon, California 92021

*Toscano Recreation Center*  
617 W. Pacheco Blvd.  
Los Banos, California 93635

*Valley Trailer Sales, Inc.*  
1650 El Camino Avenue  
Sacramento, California 95815

*Western Motors Rec. Center*  
1900 Lakeville - Hwy. 116  
Petaluma, California 94952

## COLORADO

*Chisman Trailer Sales*  
2500 East Boulder Street  
Colorado Springs, Colorado 80909

## CONNECTICUT

*Camperama, Inc.*  
Mill Plain, Rte. 6  
Between Exit 1 & 3, I-84  
Danbury, Connecticut 06810

## DELAWARE

*Richard Rice Trailer Company, Inc.*  
2343 South Dupont Hwy.  
Dover, Delaware 19901

## FLORIDA

*Airstreams by General*  
5610 Okeechobee Road  
West Palm Beach, Florida 33406

*Bell's Trailer Park & Sales*  
Route 4, Box 382  
Highway 90, West  
Tallahassee, Florida 32310

*Camptown USA, Inc.*  
23905 SW 132nd Avenue  
Miami, Florida 33171

*Carpenter's Campers, Inc.*  
8450 Pensacola Boulevard  
US 29 North, Between 1-10 and 90  
Pensacola, Florida 32504

*Kropf Eldorado, Inc.*  
6915 14th Street West (U.S. 41, S)  
Bradenton, Florida 33507

*Pleasure World, Inc.*  
5408 San Juan Avenue  
Jacksonville, Florida 32210

*Indian River Trailer Sales*  
5855 U.S. Highway 1  
Cocoa, Florida 32922

*Indian River Trailer Sales, Inc.*  
5001 Sand Lake Road  
Route 528, 1 mile E. of I-4  
Orlando, Florida 32809

*C. J. Stoll, Inc.*  
5985 - 34th Street, North  
U. S. 19  
St. Petersburg, Florida 33714

## GEORGIA

*Airstreams by Davis*  
5840 South I-75  
Forest Park, Georgia 30050

*Biltmore Gardens Travel Trailers*  
4707 Ogeechee Road  
U.S. Highway 17 South  
Savannah, Georgia 31405

## IDAHO

*Youree Motor Company, Inc.*  
664 Main Avenue, South  
Twin Falls, Idaho 83301

## ILLINOIS

*Crystal Valley, Inc.*  
4220 Northwest Highway  
US 14 at Route 31  
Crystal Lake, Illinois 60014

*Rocket Trailer Sales*  
Route 30 and Sixth Avenue  
Rock Falls, Illinois 61071

## INDIANA

*Berning Trailers Sales*  
5220 New Haven Avenue  
Fort Wayne, Indiana 46803

*Elkhart Travel Center, Inc.*  
3008 S. Nappanee Street  
Elkhart, Indiana 46514

*Four Seasons Trailer Sales Corp.*  
8225 W. Washington Street  
Indianapolis, Indiana 46231

*Recreation Unlimited, Inc.*  
P.O.Box 2219  
912 E. 53rd Street  
Anderson, Indiana 46011

## IOWA

*Barrows Camp O Rama*  
1912 Washington Boulevard  
Camanche, Iowa 52730

*Ace Fogdall, Inc.*  
5324 University Avenue  
Cedar Falls, Iowa 50613

*Imperial R V Center*  
1727 Ankeny Road  
Ankeny, Iowa 50021

## KANSAS

*Scholfield Winnebago, Inc.*  
*dba Scholfield's Boulevard Trailers*  
5617 West Kellogg  
Wichita, Kansas 67209

## KENTUCKY

*Crouch Campers & Trailers*  
4450 Clarks River Drive  
Hwys. 60 - 62 - 68 SE  
Paducah, Kentucky 42001

*Murphy Sales Company, Inc.*  
10013 Brownsboro Road (Ky 22)  
1/2 Mi. E. off Jefferson Freeway  
Louisville, Kentucky 40222

*Murphy Sales Company, Inc.*  
P. O. Box 404  
Winchester Road (U. S. 60W)  
Mt. Sterling, Kentucky 40353

## LOUISIANA

*Camper Village*  
15838 Florida Blvd.  
Baton Rouge, Louisiana 70815

*Travel Center, Inc.*  
3625 Industrial Drive  
I-20 at Fosters Road  
Bossier City, Louisiana 71010

## MARYLAND

*B & J Trailer Sales*  
P.O.Box 369  
U.S. Route 40  
Aberdeen, Maryland 21001

## MAINE

*Giant Advance Camper Country*  
765 Center Street  
Auburn, Maine 04210

## MASSACHUSETTS

*Mosher Travel Trailer Center, Inc.*  
Blue Jay 4 Corners  
Sutton, Massachusetts 01527

*Donahue's Trailer Sales*  
88 Mountain Road, Box 126  
Burlington, Massachusetts 01803

## MICHIGAN

*Bob Frank Trailer Sales, Inc.*  
1416 West Columbia  
Battle Creek, Michigan 49015

*Kolbe Trailer Sales*  
4401 East Eight Mile Road  
Warren (Detroit), Michigan 48091

*Leisure Wheels, Inc.*  
3098 W. Huron  
Pontiac, Michigan 48054

*Moore's Recreation*  
1222 E. North Territorial Rd.  
Whitmore Lake, Michigan 48189

*Northwoods Trailer Sales*  
G-6369 North Dort Highway  
Mt. Morris, Michigan 48458

*Osborne Camping Center*  
6936 South Cedar  
Lansing, Michigan 48910

*Vicars Trailer Sales, Inc.*  
9080 Pelham at Wick  
Taylor, Michigan 48180

*Woodland Travel Center, Inc.*  
5190 Plainfield Road  
Grand Rapids, Michigan 49505

## MINNESOTA

*Camperland, Inc.*  
Rural Route No. 1, Highway 52  
Rochester, Minnesota 55901

*Hart Trailer Sales, Inc.*  
Highway 71  
Long Prairie, Minnesota 56347

*Minnesota Trailer Sales, Inc.*  
11350 Highway 65, N.E.  
Minneapolis, Minnesota 55434

*Rhude Recreation, Inc.*  
P.O.Box 528  
3032 Beltline  
Hibbing, Minnesota 55746

## MISSOURI

*Bill Thomas Camper Sales, Inc.*  
5217 N. Lindbergh Blvd.  
Bridgeton (St. Louis), Missouri 63042

*I-44 Recreational Vehicles, Inc.*  
P.O.Box 93  
S. Side Halltown Exit on I-44  
14 Mi. W. of Springfield, Mo.  
Halltown, Missouri 65664

*Kansas City Trailer Sales, Inc.*  
11530 South 71 Highway  
Kansas City, Missouri 64137

*Wineinger, Inc.*  
3408 S. Belt Highway  
St. Joseph, Missouri 64503

## MONTANA

*Modern Equipment Company, Inc.*  
4025 - 10th Avenue, South  
Great Falls, Montana 59401

*Northland Travel Center*  
5124 Laurel Road  
Billings, Montana 59101

## NEBRASKA

*Autosport RV Center*  
6101 "L" Street  
Omaha, Nebraska 68117

## NEVADA

*"95" Trailer Sales*  
N. Rancho Drive  
Las Vegas, Nevada 89106

*Webb's Travel Trailers*  
295 Kietzke Lane  
Reno, Nevada 89502

## NEW JERSEY

*Sherwood Mobile Home Sales, Inc.*  
Route 78 and 173 Interchange  
Box 94  
Bloomsbury, New Jersey 08804

*South Jersey Travel Trailer Center, Inc.*  
Route 47, Delsea Drive  
Franklinville, New Jersey 08322

## NEW MEXICO

*Gunn's Recreational Vehicles, Inc.*  
12020 Central Avenue, S.E.  
Albuquerque, New Mexico 87123

## NEW YORK

*Atlantic Trailer Sales*  
1226 Fairport Road  
Fairport, New York 14450

*Callahan's Trailer Sales*  
R. D. No. 1, Route 15  
Lindley, New York 14858

*Carson Rotary Service*  
321 Bridge Street  
Vestal, New York 13850

*Ken's Camper Sales*  
Noxon Road  
Poughkeepsie, New York 12603

*Maroone Family Travel Center, Inc.*  
2550 Walden Avenue  
Exit 52, East from N.Y. Thruway  
Buffalo, New York 14225

*Niblack Trailer Sales*  
691 McLean Avenue  
Corner N. Y. Thruway  
Yonkers, New York 10704

*O'Malley Enterprises, Inc.*  
P. O. Box 116  
Traffic Circle, Rt. 9 & 7  
Latham, New York 12110

*Ralph's Sport Center*  
R.D. 5, Route 57  
Fulton, New York 13069

## NORTH CAROLINA

*College Park*  
4208 New Bern Avenue  
Raleigh, North Carolina 27610

*College Park*  
North Church Street Ext.  
U.S. 301 & 301A North  
Rocky Mount, North Carolina 27801

*Faires, Inc.*  
Box 5205, Routes 29 & 49  
3217 North Tryon Street  
Charlotte, North Carolina 28206

*Hawley's Cycle & Camping Center, Inc.*  
4784 Raeford Road  
Fayetteville, North Carolina 28304

*Out Of Doors Mart, Inc.*  
Drawer 799  
1-40 at Sandy Ridge Road Exit  
Kernersville, North Carolina 27284

**NORTH DAKOTA**  
*McLaughlin Equipment Co.*  
320 27th Street, South  
Fargo, North Dakota 58102

**OHIO**  
*Avalon Travel Center, Inc.*  
11761 Portage Road  
Canal Fulton, Ohio 44614

*Buckeye Airstream Service & Sales, Inc.*  
Baltimore Road - Box 13  
North of East I-70 on 310 at Route 40  
Etna, Ohio 43018

*Camping World, Inc.*  
37200 Vine Street  
Willoughby, Ohio 44094

*Coachman Camping Center*  
410 East Sandusky Street  
Findlay, Ohio 45840

*H. & H. Mobile Home Sales, Inc.*  
P. O. Box 108  
Piqua, Ohio 45356

*Marine Mart Trailer Sales*  
8750 Harrisburg Pike  
3 mi. S. of I-71 on U.S. 62 & 63  
Harrisburg, Ohio 43126

*Murphy Travel Trailers of Ohio, Inc*  
11526 Chester Road  
I-75 at Howard Johnson  
Cincinnati, Ohio 45246

*Parklane Recreational Vehicles*  
Route 224  
Canfield, Ohio 44406

*Richland Travel Trailers*  
2607 Emma Lane  
I-71 & Route 30  
Mansfield, Ohio 44903

*Frank B. Ricketts Travel Trailers*  
P. O. Box 683  
I-77 at US 40  
Cambridge, Ohio 43725

*Sylvan Industries, Inc.*  
dba Sylvan Airstream  
5247 Alexis Road  
Sylvania, Ohio 43560

**OKLAHOMA**  
*Brassfield Mobilhomes*  
7227 NW 39th Expressway  
Bethany, Oklahoma 73008

**OREGON**  
*Casade Trailer Sales*  
1876 Highway 99 North  
Eugene, Oregon 97402

*Spencer Mobile Homes, Inc.*  
9341 S. E. 82nd Avenue  
Portland, Oregon 97266

**PENNSYLVANIA**  
*Farnsworth Camping Center*  
Route 54  
Elysburg, Pennsylvania 17824  
*Glasgow Recreational Vehicles, Inc.*  
1650 Lincoln Way, East  
Chambersburg, Pennsylvania 17201

*Trav-L-Homes*  
Lewis Road  
Royersford, Pennsylvania 19468

*Turner Airstream Sales*  
412 Lincoln Highway, West  
Jeannette, Pennsylvania 15644

*Universal Motor Sales*  
1030 North Main Street  
Route 8 & 422  
Butler, Pennsylvania 16001

*Village Green Trailer Sales Company*  
M. R. 26 (Route 452)  
Media, Pennsylvania 19063

*Wise Trailer Sales*  
Division of F. W. Wise Gas Co.  
1501 Airstream Way  
Clearfield, Pennsylvania 16830

**RHODE ISLAND**  
*Arlington Trailer Sales*  
966 Quaker Lane, Rte. 2  
Warwick, Rhode Island 02818

**SOUTH CAROLINA**  
*Crescent Travel Home Center*  
4080 Broad Street  
Sumter, South Carolina 29150

*Dixie Lee Trailer Sales*  
P. O. Box 306  
Highway U. S. 1 & 78  
Clearwater, South Carolina 29822

*Skyway Trailers*  
Box 262 - U.S. 25 at 276  
4 Mi. N. of Greenville  
Travelers Rest, South Carolina 29690

**SOUTH DAKOTA**  
*Spader, Inc.*  
55 North Cliff, Box 963  
Sioux Falls, South Dakota 57101

**TENNESSEE**  
*Jim Crowder Recreational Vehicles*  
Route 4, Bristol Highway  
Johnson City, Tennessee 37601  
*Cullum & Maxey Camping Center*  
Elzie Miller Road  
Donelson (Nashville), Tennessee 37214

*Jewell's Camping Center*  
Route 4, Highway 45  
Trenton, Tennessee 38382

*Bobby Jones Trailer Sales*  
4222 James Road (in Raleigh)  
Memphis, Tennessee 38128

*Lansford Camper Sales, Inc.*  
5811 Lee Highway  
Chattanooga, Tennessee 37421

**TEXAS**  
*A and A Trailer Sales*  
118 Arnold Boulevard  
Abilene, Texas 79605

*Abbott Trailer Sales*  
408 Avenue Q  
Lubbock, Texas 79401

*Austin-Buda Trailer Center*  
I-35 at Niederwald Overpass  
Buda, Texas 78610

*Baker Travel Trailers*  
5301 Highway 121-A  
Fort Worth, Texas 76117

*Bear Trailer Sales*  
1630 S. Beckley (I-35) S.  
Lancaster, Texas 75146

*D & M Trailer Sales, Inc.*  
3900 I 40 East  
Amarillo, Texas 79103

*Land Yacht Trailer Sales, Inc.*  
4616 Titanic Avenue  
El Paso, Texas 79904

*Lloyd's Trailer Sales, Inc.*  
350 Twin City Highway  
Port Neches, Texas 77651

*May Trailer Sales*  
1715 N. Stemmons Freeway  
Lewisville, Texas 75067

*Otis Thomas Sales, Inc.*  
2606 Jacksboro Highway  
Wichita Falls, Texas 76302

*South Texas Trailers & Supplies*  
P. O. Box 880  
Highway 77, South  
Sinton, Texas 78387

*Traveltown Texas, Inc.*  
9600 IH 35 North  
San Antonio, Texas 78233



## UTAH

*Intermountain Trailer Co., Inc.*  
3776 Wall Avenue  
Ogden, Utah 84401

## VIRGINIA

*Bay Camping, Inc.*  
3757 Bonney Road  
Virginia Beach, Virginia 23452

*Cheek & Shockley Auto & Trailer Sales*  
2712 W. Broad Street  
Richmond, Virginia 23220

*James River Camper Sales, Inc.*  
P. O. Box 834, U.S. 460 East  
Lynchburg, Virginia 24505

*Travel Trailers of Virginia*  
P. O. Box 1089  
2211 South Main Street  
Harrisonburg, Virginia 22801

## WASHINGTON

*Baydo's Trailer Sales*  
101 West Columbia Drive  
Kennewick, Washington 99336

*Central Trailer Exchange, Inc.*  
14433 Pacific Highway, South  
Seattle, Washington 98168

*Tveten Motor Company*  
45th and Pacific Avenues  
Tacoma, Washington 98408

## WEST VIRGINIA

*Airstream by Stanley*  
P. O. Box 1545  
1400 N. Eisenhower Drive  
Beckley, West Virginia 25801

*Don's Travel Trailers*  
459 Winfield Road  
U.S. 35 at 60  
St. Albans, West Virginia 25177

## WISCONSIN

*Donna Lee Inc.*  
dba Du-B-Do Sales & Service  
Route 4, Box 182E  
Mosinee, Wisconsin 54455

*Northside Trailer Sales, Inc.*  
N 56 - W 13180 Silver Spring Rd.  
1 Mile W. of Highway 100  
Menomonee Falls, Wisconsin 53051

*Spitzer Trailer Sales*  
2300 W. Beltline Hwy.  
Middleton, Wisconsin 53562

*Swee Trailer Sales*  
U.S. 51 and U.S. 2  
Hurley, Wisconsin 54534

## WYOMING

*B & B Trailer Sales*  
P. O. Box 1747  
Jackson, Wyoming 83001

## CANADA

*Barber Motors, Ltd.*  
19 - 2nd Street  
Weyburn, Saskatchewan, Canada

*Can-Am Trailers, Ltd.*  
P. O. Box 370  
Highway 4, ½ mile N. 401, Exit 19  
Lambeth, Ontario, Canada

*Claynor Trailer Sales*  
20720 - 42nd Avenue  
Langley, B.C., Canada

*Laurentian Trailer City, Ltd.*  
1260 Boulevard LaBelle  
Route 11  
Blainville (St. Therese), Quebec, Canada

*Totem Trailers, Ltd.*  
85 Plains Road, West  
Burlington, Ontario, Canada

*Totem Trailers, Ltd.*  
1701 Dundas Highway East  
Mississauga, Ontario, Canada

*Travel Trailers Western, Ltd.*  
6006 - 104 Street  
Edmonton 70, Alberta, Canada

*Twin City Trailer Sales, Ltd.*  
P. O. Box 395  
Dartmouth Highway  
Bedford, Halifax Co.  
Nova Scotia, Canada



Jackson Center, Ohio



Cerritos, California

# Wally Byam Stores

To make trailering more enjoyable, there are Wally Byam Stores established at the majority of Airstream dealers. All Airstream dealers have the opportunity of purchasing for you the necessary equipment which would enable you to enjoy your new Airstream trailer to the utmost. The Wally Byam Stores authorized dealerships stretch from coast to coast, and these dealers stock hundreds of items which are tested and approved by travel experts. Be sure and get a Wally Byam Stores Catalog from your dealer or write to:

Wally Byam Stores  
Ohio Building  
Ohio Avenue  
Sidney, Ohio 45365

The following is a list of equipment we recommend:

1. First aid kit
2. Flashlight
3. Fire extinguisher (B:C-type)
4. Emergency road flares
5. Handi-Roll Trailer Tool File — with small hand tools — hammer, pliers, crescent wrench and screwdrivers. Rec-V Tool Kit — contains: one 4 in 1 screwdriver with slotted and Phillips head bits, Scrulox square recessed bits #1 and #2, plus clutch head double end bits 5/32" and 3/16".
6. Crosstype lug wrench for trailer wheels
7. Pop rivets (3 sizes) plus pop rivet gun
8. Battery booster cables
9. Tire gauge (up to 100 lbs. P.S.I.)
10. Hitch ball lube
11. Small bi-directional spirit level
12. Heavy-duty turn signal flasher
13. Four stabilizing jacks
14. Leveling ramps and chocks to fit against and under tires for leveling, and to prevent trailer from moving while parked
15. Spare tire for single axle trailers
16. One 50 ft., one 25 ft. length of 5/8" high pressure water hose, spare rubber washers and two "y" connections with caps which enable two trailers to be hooked up to one faucet
17. Two plastic pails for carrying fresh water
18. Quick disconnect garden hose coupling
19. One 10 ft. or 20 ft. sewer hose and coupler
20. One rubber sewer elbow, plus two 2½ to 3¾ adjustable hose clamps
21. One Thetford sewer hose adaptor (elbow or straight)
22. One 1/2 gal. holding tank cleaner and deodorizer
23. 50 ft. electric cord (#12-3 wire) with a 30 amp. capacity
24. Cord adapter, 3-15 amp. and service cord adaptor
25. Spare 20, 40 and 50 amp. cartridge fuses and light bulbs (see pages 66-67 for sizes)
26. Can of Spra-Kleen
27. Short handled shovel (G.I. type, Army surplus)
28. Cleaning equipment: broom, sponges, mop, polish, wax, a good acrylic cleaner
29. Bathtub stopper (adjustable type)

# Tow Car Equipment

If you plan to buy a new car to tow your Airstream, we suggest that you include in your purchase the trailer towing options offered by most automobile manufacturers. These include such things as an oversized generator and radiator, heavy duty springs and shock absorbers, automatic transmission cooler, oversized fan, heavy duty flusher unit and others, depending on the make of the vehicle.

Transmissions may be manual or automatic, but an automatic transmission will prolong your car's engine life and does a better job of controlling engine loads than the average driver using a manual shift.

Having adequate power is very important when considering the purchase of a new car or the trailer towing capability of your present one. Emission controls that are required by the Federal Government have reduced overall engine power. To determine generally what the tow capability of your car is, divide the total weight of your trailer by the cubic inch displacement of your automobile engine. This ratio should be between 10 and 20 pounds of trailer weight per cubic inch of engine displacement with 15 pounds per cubic inch considered optimal. For example, with a 31' Airstream weighing 6500 pounds totally loaded for travel and a car with 400 cubic inch displacement engine, divide 6500 by 400 giving a value of 16.25 pounds of trailer

weight per cubic inch engine displacement. This is very close to the optimal value and the automobile should have adequate power for towing the trailer. Remember that engine power is only one indication of the car's towing capabilities; the axle ratio and cooling capabilities certainly must be considered. We suggest you review the owner's manual of your present car and discuss your automobile towing capabilities with your Airstream dealer and your automobile dealer.

The majority of new trailerists carry more food and other supplies than really needed. Remember that every item you take along is one more thing to stow and adds weight to the total load you must pull. Consolidate items in shelves, lockers, and in the refrigerator. It is better to have one full and one empty locker than two half empty ones. Special care must be taken not to overload the front and rear ends of the trailer.

See tire section for correct tire sizes and pressures for your trailer and load on page 15.

# Chassis

The Dura-Torque axle is designed to last the life of your trailer without service, except for lubrication of the wheel bearings. Under no circumstances should welding be done on or near the axle.

The Kelsey Hayes Brakes are operated by 12 volt current from your car and must be hooked up so that you have an integral system with your car brakes. To prevent problems and insure satisfactory braking action, install a Kelsey Hayes Controller (or equivalent) and selective resistor in line with the controller in your car.

A Kelsey Hayes Controller (or equivalent) installed in your car will synchronize the trailer brakes with your car brakes. It is designed to apply the trailer brakes just before your car brakes. To adjust, turn the handle counterclockwise to apply trailer brakes earlier and clockwise to apply trailer brakes later. The controller will hold this setting.

A selective resistor to match the weight of your trailer to the controller should be installed on the fire wall of your engine compartment. It should be correctly adjusted during installation. However if you wish to change the action of your brakes proceed as follows:

Check the initial trailer brake application with

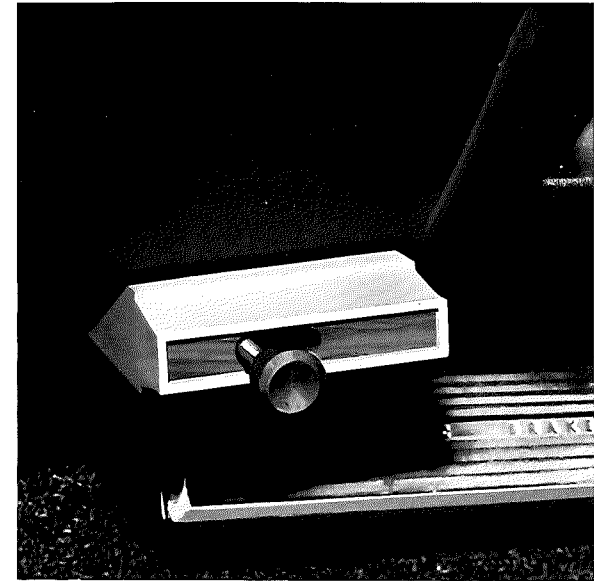

*Trailer Brake Controller*

the controller fully applied (clockwise). If the resistor setting is correct, the controller full "on" position should provide firm braking action just short of skidding on dry pavement. Follow the chart below and change the setting to achieve greater or less braking, as required. The adjustment setting of the controller and the selective resistor should be checked by your dealer during regular maintenance inspection.

### *Selective Resistor*

Setting shown is for 12 volt tow car with 12 volt brakes, and trailers with 2 axle-4 brake arrangement.

Model	Trailer Wt. (lbs.)	Setting
31 Ft.	6500 - 7100	

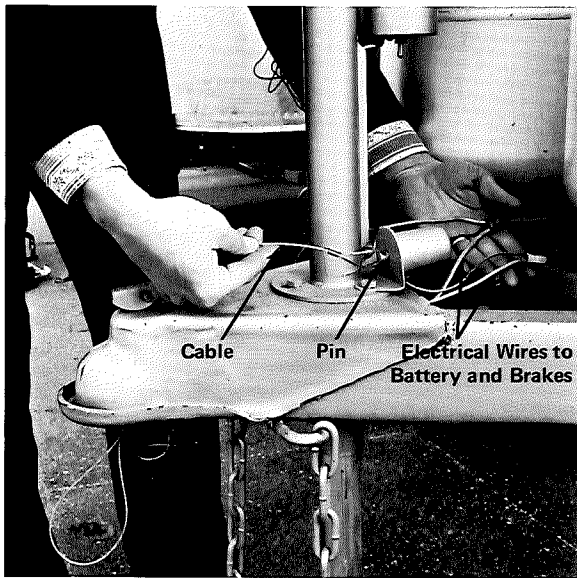

*Break Away Switch*

*Brake Adjustment*

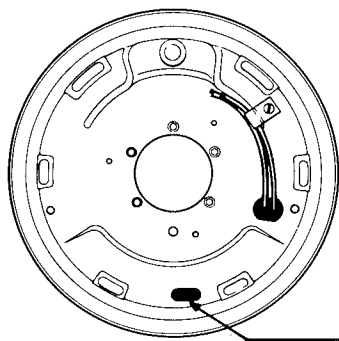

Adjusting hole.

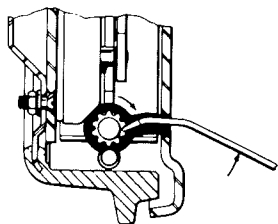

To tighten, turn clockwise.

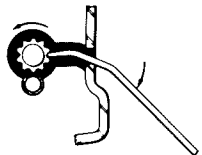

To loosen, turn counterclockwise.

In the event of an accidental separation of the tow car and trailer, the break-away switch is a device which will set and lock the trailer brakes for a sufficient length of time to stop the trailer. The switch is activated when the small pin in the front of the unit is pulled out by the wire attached to it and to the car. This pin should be pulled out, lubricated with light household oil and replaced every 90 days.

When the trailer is connected to the tow car, the break-away switch loop should be attached to the permanent frame of your hitch. When disconnecting trailer from tow car, remove wire loop from the frame, do not remove pin from switch, because this will apply the trailer brakes.

Airstream recommends that your brake system be checked and adjusted by a Certified Service Center. However, in emergencies, to adjust brakes:

1. Remove the small rubber plug at the base of the backing plate on the brake drum.
2. Jack the wheel up so that you can spin it by hand. Tighten the brakes (using a brake adjusting tool or a screwdriver that has been bent to a 90° angle) until the wheel is locked, then back off until you have a free spinning wheel, which will be approximately 8 notches.
3. Repeat this operation with all trailer wheels.

# Load Chart

Model	Gross Vehicle Weight Rating G.V.W.R.	Factory Weight Without Options	Allowable Additional Weight*
Rear Bath T	7100	5035	2065
Rear Bath D	7100	5065	2035
Center Bath T	7100	4975	2125
Center Bath D	7100	4970	2130

T = Twin Bed Models  
D = Double Bed Models

\*Allowable additional weight includes all options and accessories, L.P.G., water, waste, food supplies, clothing, other personal cargo, etc.

## Option Weights

Battery Charger .....	90 lbs.
Bunk Bed .....	45 lbs.
Hanging Wardrobe .....	10 lbs.
Space Locker - Long .....	20 lbs.
Space Locker - Short .....	15 lbs.
Spare Wheel Bracket .....	9 lbs.
Spare Wheel and Tire .....	60 lbs.

## Variable Weights

L.P.G. per full tank	7½ gal. ....	30 lbs.
	10 gal. ....	40 lbs.
Water Tank	45 gal. ....	373 lbs.
Water Heater	10 gal. ....	83 lbs.
Main Holding Tank -		
Rear Bath	20 gal. ....	166 lbs.
Center Bath	17 gal. ....	141 lbs.
Auxiliary Holding Tank -		
Rear Bath	10 gal. ....	83 lbs.
Center Bath	17 gal. ....	141 lbs.

ADD TIRE ROTATION DIAGRAMS  
WITH  $\frac{1}{2}$  w/o SPARE

# Tires



Tire Changing

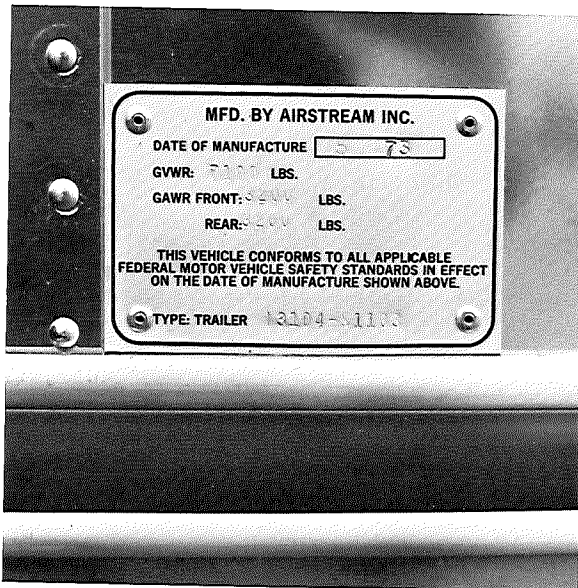

Gross Vehicle Weight Rating

Your Airstream is equipped at the factory with Michelin radial steel belted tires. Airstream dealers cannot make adjustments to tires. This must be done by a dealer who handles that particular brand. If you ever have tire problems, check the local telephone directory for the nearest dealer.

To get the maximum performance from your tires check the air pressure often, but only when the tires are cool. Never bleed out air immediately after driving. Recommended tire pressures vary with load conditions. For specific pressures refer to the table below.

It is also important to periodically check on the tightness of the lug bolts. They should be tightened to a torque of 90-95 ft.-lbs. on the forged aluminum wheel. Care should be taken at all times when handling the forged aluminum wheel because of possible damage to its appearance.

Park out of the sun in warm climate whenever possible. In desert regions use tire covers to prevent ultra-violet deterioration.

To change a tire with a jack, see the label affixed to the underbelly just to the rear of the wheels. This indicates the proper jack placement. On tandem axle models a flat tire may be changed without the aid of a jack. Drive the unit up a ramp 8" wide, 6" high and about 3 feet long at the base (see photo).

All tire, wheel, hub and drum assemblies are dynamically balanced at the factory. Be sure to rebalance the tire, wheel/hub, and drum assemblies each time a tire is changed or rotated.

In an emergency remove the flat tire and the independent suspension of the Dura-Torque Axle allows a four wheel unit to be safely towed on three wheels for a short distance (100 miles maximum) and only at a low speed (30 MPH). Be especially cautious in crossing holes or dips in the road. It is good practice to set your rear view mirrors so that you can observe your tires at all times.

Per Federal Regulations, your trailer is placarded on the front roadside area with a gross vehicle weight rating and a gross axle weight rating. The gross vehicle weight rating is the maximum the trailer can weigh when it is being towed. The gross axle weight rating is the maximum load that can be on each axle when the trailer is being towed. Refer to Load Chart (page 14) as a guide for the amount of weight that may be added to your trailer. Personal cargo added to the trailer should be evenly distributed, with heavier items placed near the axles. The tongue weight should be 10% to 15% of the trailer's loaded weight.

*Tire Pressure (cold inflation)*

7.00 - 15XC steel radial	6-ply	52 p.s.i.
-----------------------------	-------	-----------

# Hitching Up

Hitching your Airstream trailer is something that will become almost second nature with practice. However, there are a few tips, learned from experience, which will help you.

The electric jack is strongly recommended for anyone who, for any reason, should not physically exert himself. Available as a factory option or through the Wally Byam Stores, the electric jack makes hitching and unhitching a much easier operation.

## Steps for Hitching Up

1. Jack up the trailer hitch until there is clearance for the hitch ball to slide under, remove safety pin and raise the locking lever.
2. Back the car straight back to the hitch. This can best be accomplished through the use of pre-arranged hand signals with the help of another person, but if you are hitching up by yourself we recommend the use of a hook-up view mirror.

3. Lower the trailer hitch onto the hitch ball; then close the locking lever and insert safety pin.

4. Now raise the trailer and car to the full height of the hitch jack and then attach the leveling bars. Lower the car and trailer. The hitch ball should be level to slightly higher (see photo). Readjust leveling bars until this condition is correct. This will result in the best balance for towing and steering control as the weight equalizing hitch distributes the hitch load. Approximately 1/3 of the load is distributed onto the front wheels of the tow vehicle, 1/3 onto the rear wheels of the tow

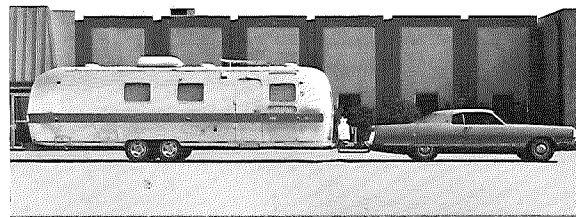

*Hitch Installation Proper – Hitch ball level to slightly higher.*

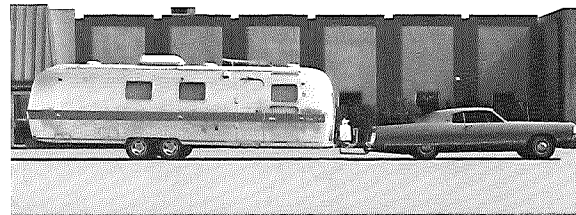

*Hitch Low – Load on front wheels too light. Need more tension on load equalizing bars.*

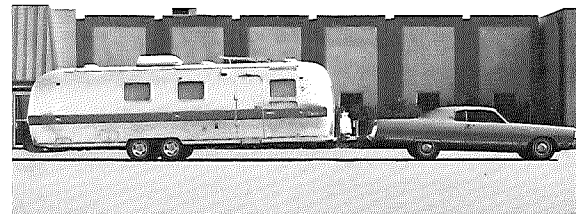

*Hitch High – Load on front wheels too heavy. Too much tension on load equalizing bars.*

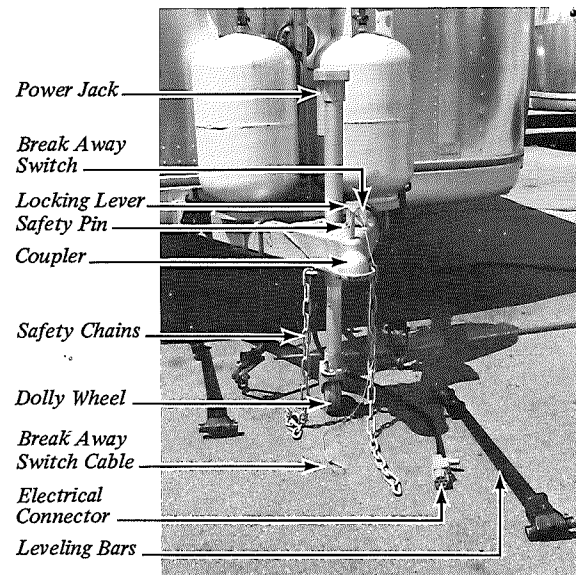

*Hitching Up Equipment*

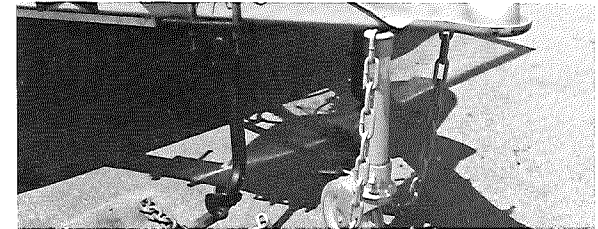

*Hitching Up Step 1.*



*Step 2.*

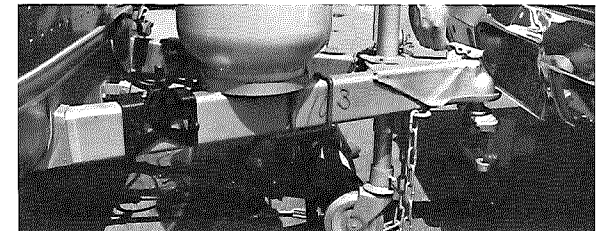

*Step 3.*

vehicle and 1/3 onto the trailer axle assembly. With proper hitch installation and hitching up the bar should have a noticeable amount of deflection or bending (see photo 4.f.). A little practice with your rig will teach you how far to pull up the bar, and you may wish to mark the chain links that match your rig. Always choose level ground for checking correct hook-up. For further information see hitch manufacturers' literature.

Note: If your car is equipped with adjustable load leveling air shocks, you must load the car first with typical luggage and passengers and bring it back to level. Then attach the trailer and adjust the load leveling bars. Otherwise



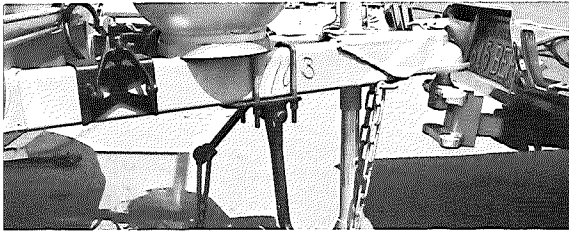

Step 4.a.

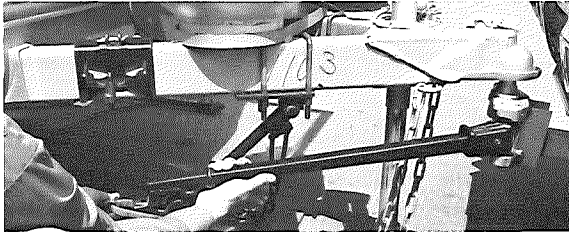

4.b.

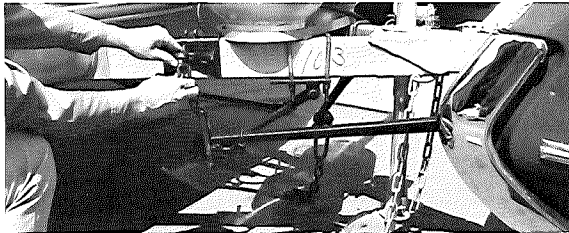

4.c.

the air shocks on your car will overload the rear wheels.

The hitch ball on your car should be installed at a height of 19-1/2" to the top of the hitch ball, measured when the car is unloaded.

A low hitch ball increases tailwagging tendencies by lowering the nose of the trailer thus changing the center of support for the trailer and reducing the weight on the front wheels of the car.

5. Plug in the electrical connector cord and check running, directional, and brake lights. The electrical connector cord should be com-

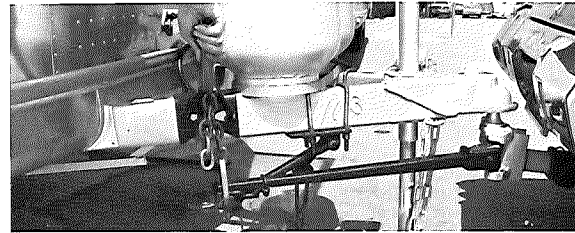

4.d.



4.e.

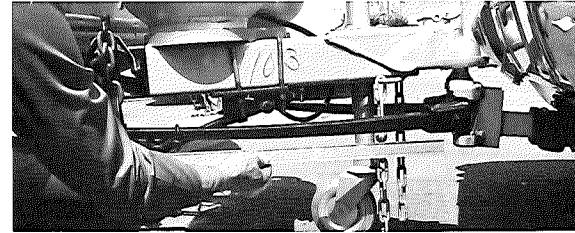

4.f.

pletely removed and stored when not in use. 6. Attach the **break-away switch cable** and the **safety chains** to the welded portion of the hitch or the car's frame, but never to the removable ball mount. Cross the safety chains under the hitch.

7. Retract the hitch jack completely for maximum ground clearance. Remove the **dolly wheel** and **jack pad**, and stow them in the car's trunk, along with leveling jack and other gear used when stopped. Never tow your trailer with the jack down or the dolly wheel on. Check that the fold-away step is up and that the main door is completely closed and locked for towing. If it is not locked the constant vibration of travel may cause it to

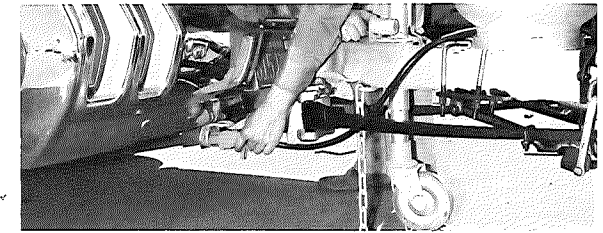

Step 5.

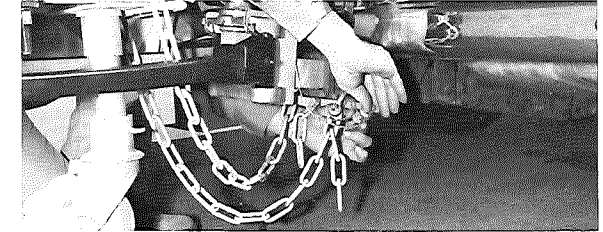

Step 6.

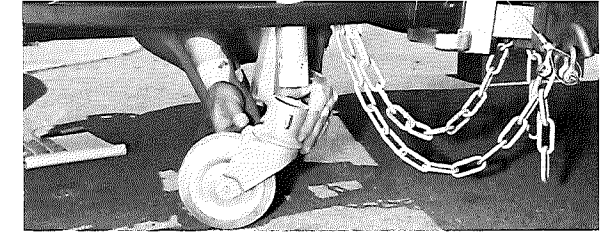

Step 7.

open with possible damage.

8. Move the rig ahead about 50 feet and test the trailer brakes, then check the ground for forgotten objects. Regularly check the condition of your tires, air pressure, and the tightness of the lug bolts. For specific tire pressures refer to page 15.

# Towing Tips

A few hours of towing practice in a large empty supermarket parking lot will make pulling your Airstream over the road much easier. Line out two corners for both left and right turns. You may also use these corners to practice backing and parking. Observe that the tracks made by the trailer wheels are distinctly different from those made by your car. Studying this will make it easier for you to correct mistakes. Truck or trailer type fender or door grip rear view mirrors are a must for maximum visibility and in most States they are required by law.

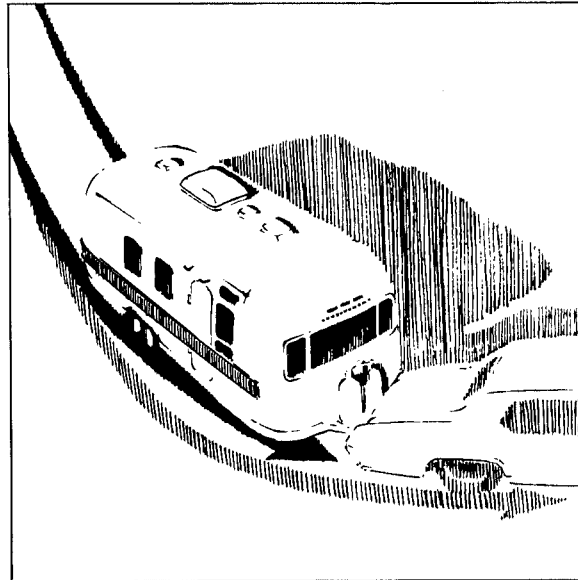

*Tracking*

You are now ready to tow. After checking the traffic, signal that you are about to pull away and start slowly. Look often in your mirrors, and observe the action of the trailer, then carefully move into the proper lane of traffic. Remember that the trailer wheels will not follow the path of the car's wheels, therefore, **wider turns are necessary when turning to the left or to the right.**

On freeways or expressways try to pick the lane you want, and stay in it. Always maintain plenty of space between you and the car ahead, at least the length of the car plus trailer, for every ten miles per hour. Remember that in order to pass another vehicle, you will need longer to accelerate. You must also allow for the length of the trailer when returning to the right hand lane. On a two lane road, cars will be lining up behind you because you travel at a lower speed. It is both courteous and sensible to signal, pull onto the

shoulder, and let them pass. Your Airstream is designed to be towed easily at any legal speed, so if you are not careful you may be inclined to forget it is there. Your car brakes will automatically apply the trailer brakes first if properly adjusted. This will make you stop as if you were driving the car alone and keep your car and trailer in a straight line.

When trailering, you might encounter a temporary cooling system overload during severe conditions — such as hot days when pulling on a long grade, when slowing down after higher-speed driving, or driving long idle periods in traffic jams. If the hot indicator light comes on and you have your air conditioning turned on, turn it off. If the light doesn't go off in about a minute, pull over in a safe place and put on your emergency brake. Don't turn off the engine. Increase the

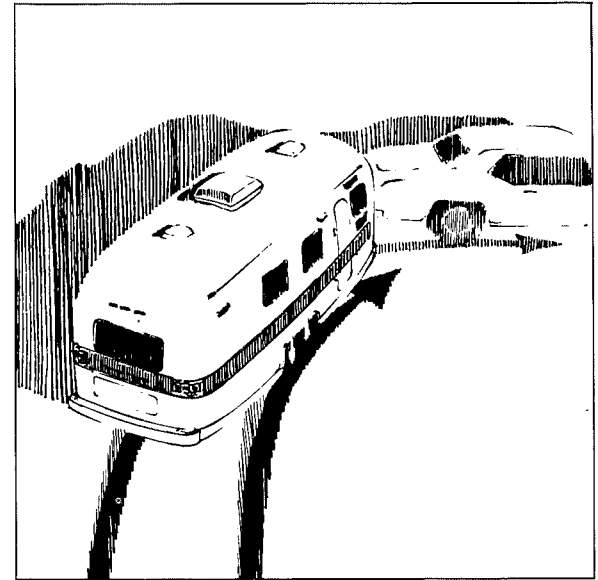

engine idle speed. Lift the engine hood and check for fluid leaks at the radiator hoses, radiator or radiator overflow outlet. Check to see that all drive belts are intact and the fan is turning. Light should go off within one minute. When the light is out, proceed on the highway a little slower. Ten minutes later resume normal driving. Caution: Never open a radiator cap when the car is hot! Check the car coolant level when the car is cool.

**When going downhill in dry weather,** down shift so that engine compression will slow the whole rig down. Take dips and depressions in the road slowly and do not resume normal driving speeds until you are sure that the trailer wheels are clear of the dip.

**On slippery pavement** do not use engine drag to help slow down as this may cause the rear

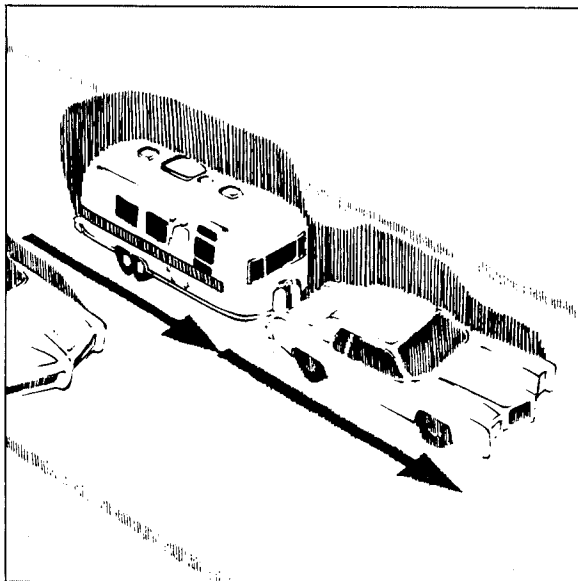

*Passing*

wheels of the car to skid. On icy pavement drive slowly and if you feel the car is skidding, gently apply the trailer brakes only. This will bring the car and trailer back into a straight line. Chains do not help trailer wheels.

**When driving in mud and sand** let the momentum carry the rig through. Apply power gently and use as little as possible. Stay in the tracks of the vehicle ahead and keep the car in the highest possible gear. If you do get stuck it is best to tow out both car and trailer together without unhitching.

If you have to tow long distances over bad roads, the stones and gravel thrown back by your tires will dent and scratch the aluminum finish of your Airstream. To prevent this, use masking tape to secure heavy sheets of card-

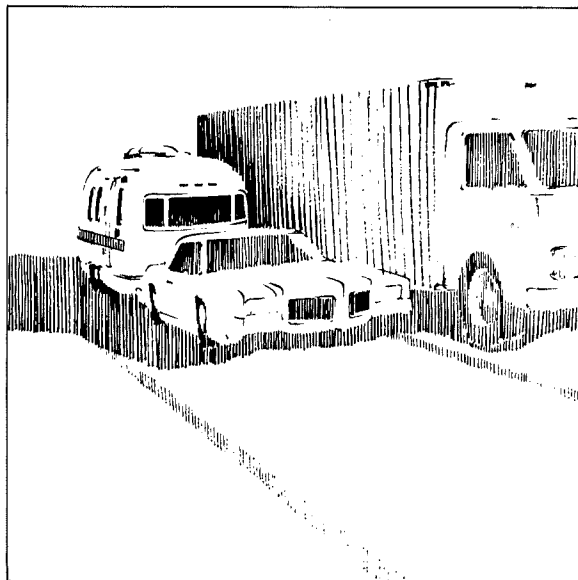

board to the lower front end of the trailer.

Despite the best hitch, you will notice that whenever a large bus or truck overtakes your rig the displaced air first pushes the trailer rear to the right and then affects the front. **Do not apply the brakes.** Steer very slightly, momentarily, toward the bus or truck. This will compensate for the sway induced by the passing vehicle.

When stopping on a hill or slope, leaving your car in gear is not enough for stand-still-safety. **Chock the trailer wheels** to be doubly sure. Never use the break-away switch as a parking brake because it will burn out the magnets and drain the trailer battery.

## Backing Up

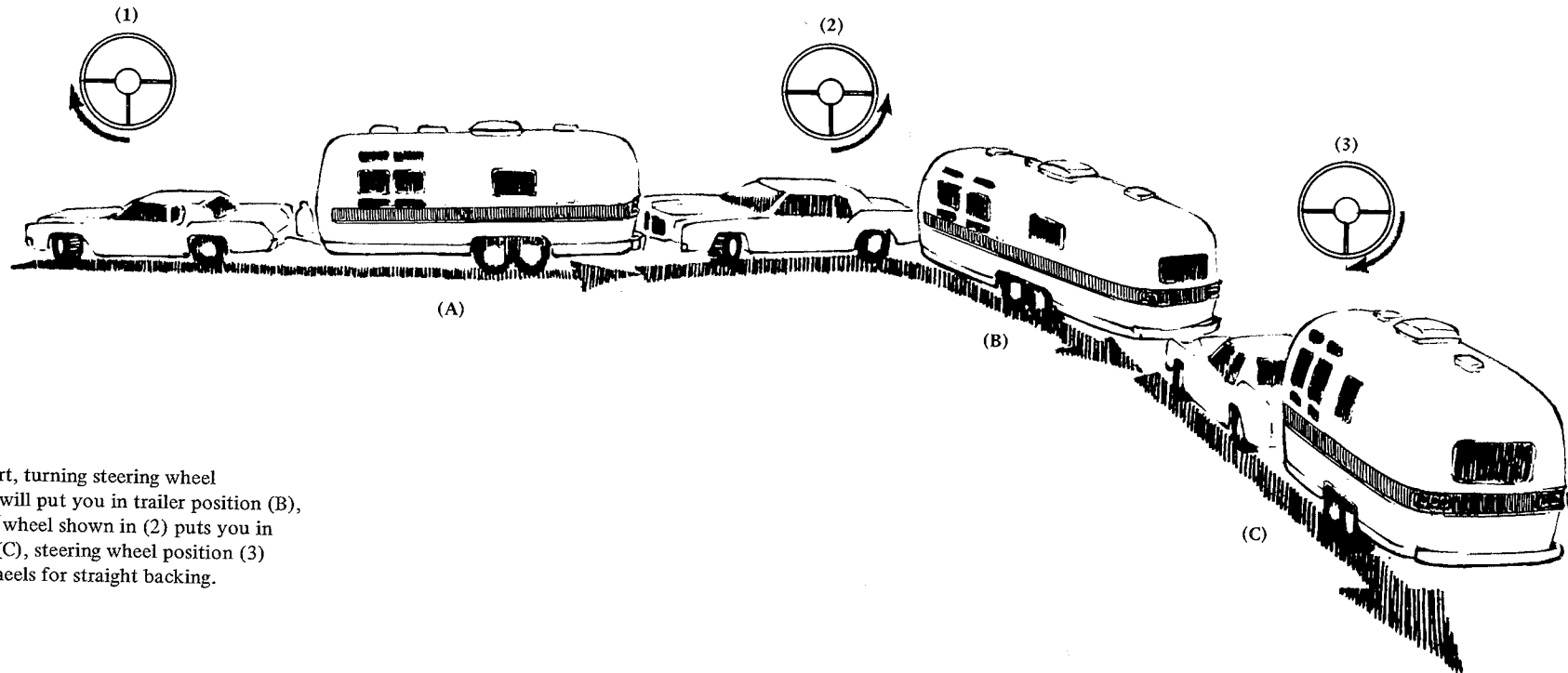

Position (A) start, turning steering wheel as shown in (1) will put you in trailer position (B), turning steering wheel shown in (2) puts you in trailer position (C), steering wheel position (3) returns front wheels for straight backing.



Indicates steering direction

In backing up, the important thing to remember is to **do everything slowly** and to correct immediately if you see the trailer turning the wrong way. Concentrate on the rear of the trailer. With your car and trailer in a straight line, back up slowly and turn the bottom of the steering wheel in the direction you want the trailer to go. Watch out the window or in the mirror until the rear of the trailer is pointing in the desired direction. Then turn the steering wheel in the opposite direction.

Your car will be following the trailer in an arc. Straighten the car and trailer by turning the steering wheel more sharply, then when they are in line, straighten the steering wheel. **Always try to back to your left because the visibility is much better.** (See illustration.) When you don't make it on the first try it is usually much easier to pull forward to your original position and start over.

# Overnight Stop

Airstream owners have parked virtually every place imaginable from filling stations to farm lands. In time you will develop a knack for spotting wonderful little roadside locations by turning off the main highway and exploring. See the end of this section for applicable state laws

There are many modern trailer parks including State, County and Federal parks with good facilities, where you may obtain hook-ups of electrical, water and sewer connections. Directories are published which describe in detail these parks and tell what is available in the way of services and hookups.

**On overnight or weekend trips**, chances are you will not use up the capacity of the sewage holding tank, deplete the water supply or run down the battery which supplies the 12 volt current.

**On a longer trip**, when you have stayed where sewer connections and utility hook-ups were not available, it will be necessary for you to stop from time to time to dispose of the waste in the holding tank and replenish the water supply. Many gas stations (chain and individually owned) have installed **sanitary dumping stations** for just this purpose. Booklets are available which list these dumping stations.

When stopping for the night your Airstream is built to be safely parked in any spot that is relatively level and where the ground is firm.



**Your facilities are with you, you are self-contained.** Unless the car is needed for transportation, it is not necessary to unhitch. Try to pick as level a parking spot as possible. **Stabilizing jacks or blocks** probably won't be required for an overnight stay; however if you put the jack pad on the hitch jack and run the hitch jack down to take the weight off the car's springs this will provide some stability. If you must park on a slope, **park facing downhill**; it is easier to level the Airstream this way.

All you need to do to enjoy the self-contained luxury of your Airstream is to:

1. Light the water heater, refrigerator and furnace pilots if required. See pages 40-48 for complete details on LPG system and gas operated appliances.
2. Turn on the gas supply at the range and light the pilot.

Before moving on, check your campsite, both for cleanliness and also to be sure you haven't left anything behind, turn off the gas supply petcock to the range and make sure everything is properly stowed. Use your Pre-Travel Check List on page 68 and you are ready for more travel adventure.

# Extended Stay

Making a long trip in your Airstream is not very different from making a weekend excursion. Since everything you need is right at hand you are at home wherever you go. When packing for an extended trip take everything you need, but only what you need.

When you plan to stay in the same place for several days, weeks, or months, you will want your trailer to be as level and steady as possible. Check the attitude of your Airstream with a small spirit level set on the inside work counter or the trailer hitch "A-Frame." If a correction is necessary then you must level from side to side first. This can be done most easily up a small ramp consisting of 2" x 6" boards about four feet long and tapered at both ends. (See photo) We do not recommend placing tires in a hole for leveling.

Level from front to rear by disconnecting the hitch from the car, putting the jack pad under the hitch jack and adjusting the jack up or down until you are level. Block or chock the wheels to keep the trailer from rolling. Use the wrench, located in the hose carrier, to lower the two B.A.L. stabilizing jacks on the low side. Bring trailer to a level position side to side. Lower opposite stabilizing units to a firm position.

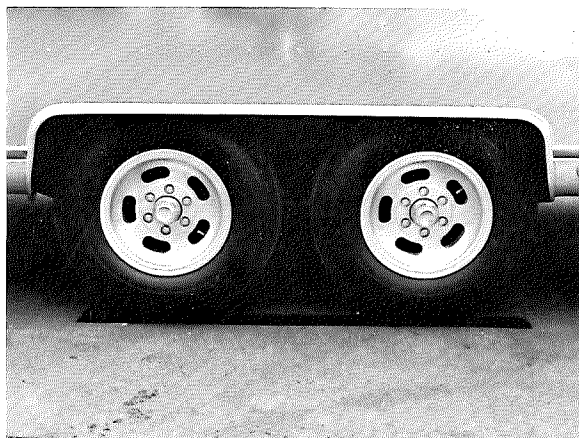

Trailer Leveling

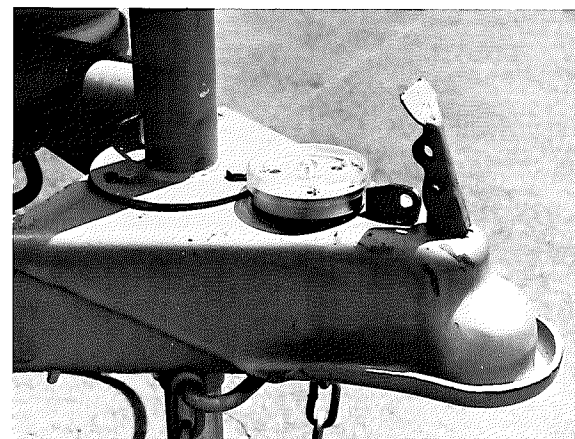

Spirit Level

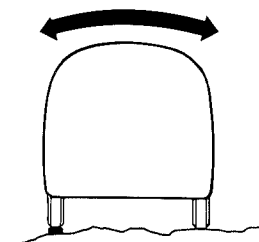

1. Level from Side to Side

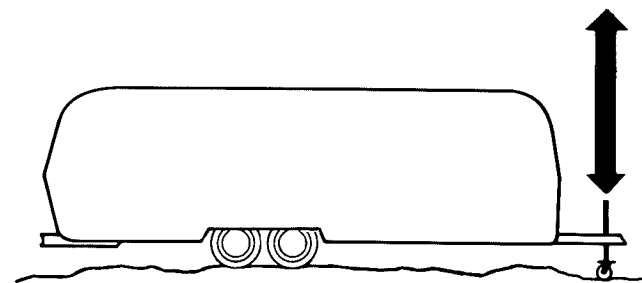

2. Level from Front to Rear

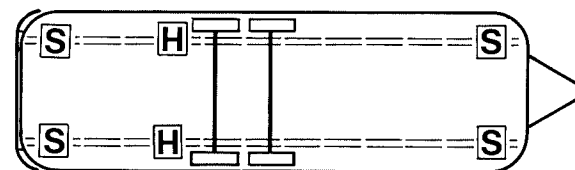
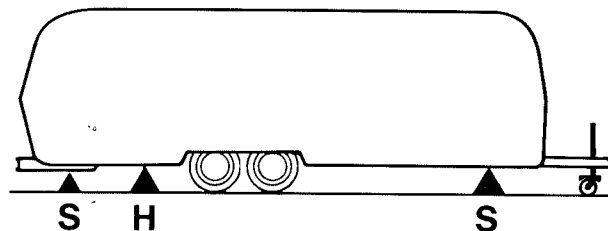

H - Hydraulic Jack Positions

S - B.A.L. Stabilizers



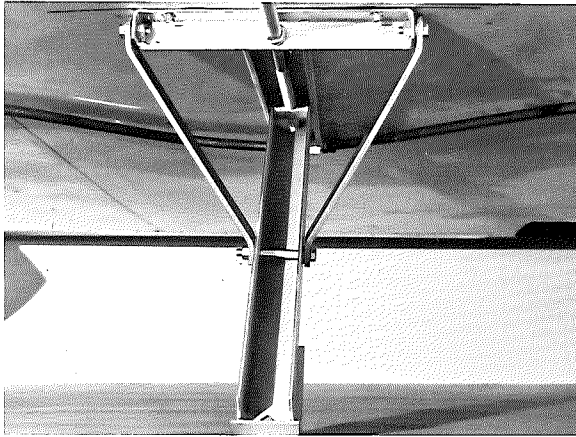

*B.A.L. Stabilizing Jack*

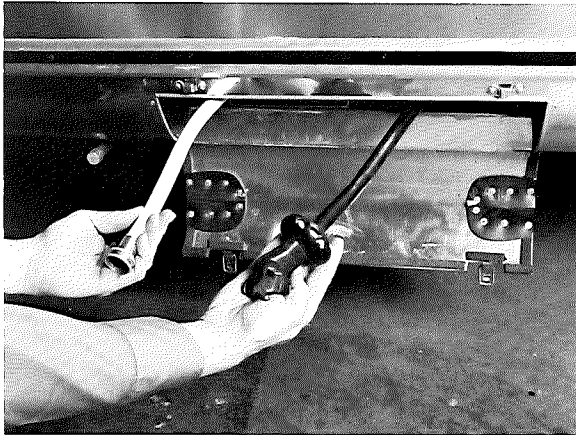

*City Water and Power Inlets*

Note: Whenever the trailer must be lifted with a jack as when changing a tire or leveling on very rough terrain, always place the jack under the main frame rail. A label is provided to indicate the proper position for the jack. Never use stabilizing jacks to lift the trailer.

The water line connection for city water and electrical connection for 120 volt, 60 cycle city power is located on the roadside of the trailer in back of the wheels. Unlatch the access cover and pull the connections out to



*Waste Drain Hose Hook-Up (Rear Bath)*

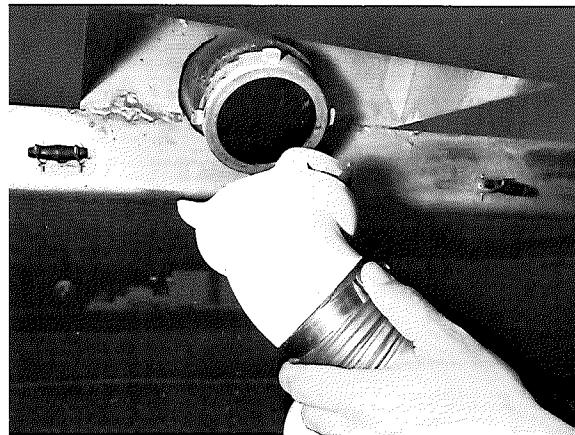

*Waste Drain Hose Hook-Up (Center Bath)*

the desired length. They will automatically lock in this position. The access door can now be closed to prevent the entry of any foreign objects. On the electrical connection, be sure you have the wire grounded and have the proper polarity (see pages 49 and 55 for water and electrical system details).

To stow the electrical cable when leaving, unlatch the access cover, unhook the electrical cable from its connection, give a slight pull on the cable, and it will automatically wind

up. To stow the water hose, move the release lever to its left hand position. Caution: Keep a light hold on the cable and hose as they are winding up so that they do not whiplash against the side of the trailer.

Hook your waste drain hose into the sewer disposal facility and attach to the drain outlet in your trailer. For details on this procedure refer to page 52.

Turn on gas supply; light the range and oven pilots, light the water heater, refrigerator and furnace pilots.

# Winter Airstreaming

Traveling in an Airstream during the cold winter months can be one of the most exhilarating experiences in all trailering. When we speak of cold, we are talking about temperatures of zero to -10 degrees. Airstreams properly outfitted with thermopane windows have been cold-soaked at -20 degrees with no adverse effects and with no real discomfort. Thermopane side windows do not require storm windows and help to improve the efficiency of the heating system.

Additionally, a battery charger that operates off the trailer's gas system, is available as an option. We recommend this option when you are planning extensive winter usage.

There are of course certain precautions which must be taken as you would in your own home in low temperatures.

1. There should be heat in the trailer at all times.
2. You must have a plentiful supply of propane gas.
3. If your stay is longer than overnight (and you do not have the battery charger option), then you should endeavor to have 110 V electricity available. The battery (fully charged) will not last more than about 10 hours in zero weather. Of course you can always run your car to recharge the battery and normally the battery will attain sufficient power to run another 9 hours by running your engine for approxi-

mately 45 minutes to one hour at fast idle. For more detailed information on the battery see page 57.

4. Minimize use of electricity if 110 volt power source is not available.
5. Your Airstream has forced air heating in the holding tank and trunk area. There is also heating around the water tank.
6. In extreme cold conditions and when 120 volt electricity is available, porcelain lamp receptacles, with 75 watt bulbs, and adequate wire guards, over bulbs, may be used. These should be permanently attached to the floor adjacent to the inside wall in the area between the inside wall of the trailer and the storage compartment below the front travel lounge. When lamps are in use this area should be emptied of all other items. This will give a more comfortable feeling to the living room area and will minimize condensation.
7. Leave cabinet doors, bed doors and wardrobe doors slightly open at night to allow circulation of air in and around all furniture components.
8. For extended stays in cold weather, insulate the water line outside the trailer.

You should remember that low temperatures in combination with high winds cause an equivalent chill temperature much below what your thermometer is reading. For instance, with an outside temperature of zero degrees and the wind velocity of 10 miles per



hour, the equivalent chill temperature is minus 20 degrees F.

There is no substitute for common sense in cold weather.



# Storage and Winterizing

When storing your trailer for short or long periods use the same precautions as you would in your own home in regard to perishables, ventilation and rain protection. In addition, for prolonged storage periods, flush out all the drain lines and the holding tanks. Also, drain the entire water system including the water heater and the water storage tank. Instructions for draining the water system are explained in the following paragraphs on winterizing.

Twice a year or after a long storage period, we suggest you take your unit in for a check-up and cleaning of the gas operated appliances.

The main consideration in winterizing is to guard against freezing damage to the hot and cold water systems, the waste drain system (including the traps), the waste-holding tanks, the water heater and the battery. To completely winterize your Airstream, follow this procedure:

1. Level the trailer from side to side and front to rear. Open all the faucets.
2. Turn the water pump switch to the OFF position.
3. Open all drain valves. On rear bath models, two are located in the rear trunk (roadside), and three are under the galley sink. On center bath models, one is located under the bed on the roadside and three are under the galley sink. On all

models one is located on the water heater accessible through the exterior access panel.

4. While the water is draining from the system, open and flush the toilet flushing valve. Depress hand spray thumb button and hold the spray head below rim of the toilet and drain the hand spray line. **There is danger of damage from freezing if water remains in these lines and valves.** Drain all water from telephone showerhead flexible hose.
5. Remove water pump check valve, located between pump outlet flexible hose and copper tubing.
6. Lower the front of the trailer as far as the jack will allow until water ceases to drain, then crank the jack up as high as it will go and let any remaining water drain out the rear drain valves.
7. Disconnect the water pump inlet connection, and with check valve removed, turn the pump by hand until all the water is expelled.
8. After the water has stopped running from the drain lines, apply air pressure, if available, to the drain lines, at city water inlet, with all drain valves and faucets still open. This will force any remaining water from the water heater and remove any water which may be trapped in low areas.
9. Pour a cup of antifreeze (Glycol) into the lavatory, sink, and tub drains to prevent freezing of water in traps.

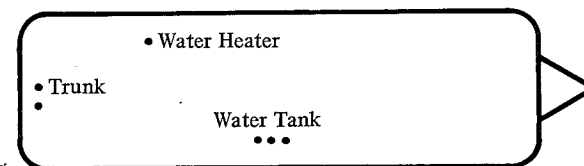

Rear Bath

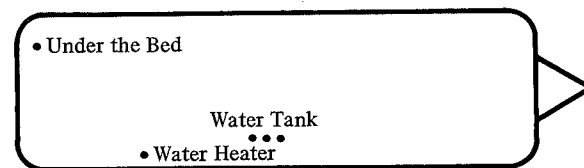

Center Bath

---

•Drain Valve Locations

10. Be sure to open the waste-holding tank drain valves and drain and flush the tanks thoroughly. (This is very important as the sewage in the tanks, if frozen, could seriously damage the tanks.)
11. Remove the lower portion of the water purifier, if your trailer is so equipped, and drain the purifier.
12. It is very important for optimum life of your battery to check it periodically and to keep it fully charged. This is especially true in winter months when the temperature may drop below freezing. Please refer to the battery section for more information on battery maintenance.
13. Remove any items (food, cosmetics, etc.) from trailer interior that might be damaged by freezing — or might damage the trailer if containers break.



**Exterior Identification**

No.	Description	Page No.	No.	Description	Page No.
1.	Roof Vent .....	37	10.	Coupler .....	16
2.	120 volt outlet .....	55	11a.	Battery compartment (rear bath) .....	57
3.	Air conditioner .....	36	11b.	Battery compartment (ctr. bath) .....	57
4.	Range exhaust vent .....	44	12.	Water inlet (tank) .....	49
5.	Main door light .....	66	13.	Furnace vent .....	46
6.	Vista view window .....	29	14.	Main door step .....	28
7.	Cluster lights .....	66	15.	Serial number plate .....	—
8.	L.P.G. tanks and regulator .....	40	16.	Exterior light .....	66
9.	Electric jack .....	16	17.	Load equalizing bars .....	16



No.	Description	Page No.
18.	Electrical connector (towing) .....	64
19.	Break away switch and cable .....	13
20.	Safety chains .....	16
21.	L.P.G. tank switch .....	34
22.	Clearance light .....	66
23.	T.V. Radio antenna .....	29
24.	Refrigerator vent .....	42
25.	Cluster lights .....	66
26.	Stop, tail, turn and backup lights	66

No.	Description	Page No.
27.	B.A.L. stabilizing jacks .....	23
28.	Refrigerator access door .....	41
29a.	Waste outlet (center bath) .....	52
29b.	Waste outlet (rear bath) .....	52
30.	Battery charger (optional) .....	58
31.	Water heater access panel .....	48
32.	Water inlet (city) .....	49
	Electrical inlet (city) .....	56
33.	License plate light .....	66

# Exterior

The Airstream exterior has been covered by an acrylic lacquer finish providing years of environmental protection. Washing the exterior of your Airstream is similar to washing an automobile. Both have high quality finishes and certain precautions must be taken to protect them. Oil, grease, dust, and dirt may be removed by washing with any mild nonabrasive soap or detergent. Automatic dishwasher detergents and acid etch cleaners are too strong and should never be used. Always clean your Airstream in the shade or on a cloudy day when the aluminum skin is cool. Cleaning should be followed by a thorough clean water rinse. Spots and streaks may be prevented by drying the unit with a chamois or a soft cloth.

After cleaning and drying, a good grade of nonabrasive automotive paste or liquid wax will increase the life of the finish, especially in coastal areas where the finish is exposed to salt air or in polluted industrial areas. It will also protect the shell from minor scratches and make subsequent cleaning easier. Wax should normally be applied every three to six months.

It is important to remove sap, seeds, gum, resin, asphalt, etc., as soon as possible after they appear by washing and rewaxing. Sunlight and time will bake-harden these materials making them almost impossible to remove without heavy buffing. If asphalt remains on the trailer after washing, use a small amount of kerosene on a rag and wipe



*Main & Screen Door Catches*

the spots individually, being careful not to scratch the aluminum.

For small areas of damage to the acrylic protective coating, or where oxidation is beginning to occur, remove all traces of the acrylic coating with a good grade of lacquer solvent and then thoroughly clean the aluminum with an aluminum cleaner. Then respray the area with clear acrylic lacquer. All items needed for these minor repairs to the exterior shell are available at Wally Byam Stores. For extensive refinishing we recommend that you contact an Airstream Service Center or the factory for instructions or to arrange for factory service. To keep your trailer looking new, paint the "A Frame," L.P.G. tanks, and rear frame periodically, by brushing on aluminum lacquer or, if possible, by spraying.

Each time you connect the 7-way electrical connector check for dirt and corrosion. Keep the contacts clean with "Spra-Kleen".

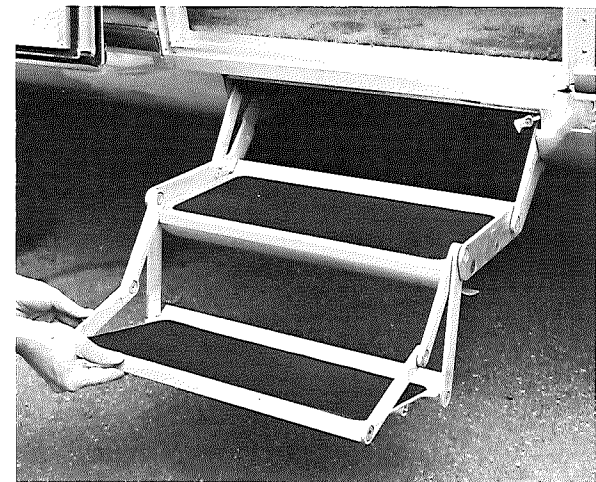

*Fold Away Step*

It is important that the main door be completely closed and locked during towing. If it is not locked the constant vibration of travel may cause it to open with possible damage.

For your security the lock has been designed as a dead bolt. For this reason never try to shut the door when it is locked. The door is properly closed when the handle is firm. If the door is difficult to open, push in to release the latch. When the door swings open it will automatically latch against the side of the trailer.

The screen door latches to the main door or operates independently using the same type latch that holds the main door open.

To operate the Fold-Away Step just press down the latch on the right hand side and the step will automatically drop into position. To stow the step simply lift the front edge and then push it up under the trailer to its stowed position.





*Motorized TV Antenna Controls*

The **Extension Step** is permanently attached to the main step and when needed it is simply flipped out. Never travel with step lowered.

Your Airstream has a new **High Strength Safety Glass Front Window** that is stronger than car windshields. Inside this window is a second window of tough acrylic plastic. The combination represents a great improvement in safety and convenience as it eliminates the need for a rock guard and also acts as a thermo pane for better temperature control.

The **windows** in your trailer are of tempered safety plate glass. To open: release the two lever locks at the bottom, pull the two side operator handles toward the center and pull down until the window is in the desired position, and place the operators into one of the five positioning holes. To close: pull the two side operator handles toward the center and slowly lift.

These windows are cleaned in the same

manner that ordinary windows are. Clean the seals with a damp cloth or mild detergent every three to six months taking care not to use strong solvents as they will damage the seals. A coat of natural silicone lubricant applied after the seal has dried will keep it flexible. Spread the lubricant evenly with a brush or finger, working it into the surface. This is a good practice for all rubber seals in your Airstream. For replacement of a damaged window contact an Airstream Service Center or the factory.

The **thermo pane side windows** include metalized mylar tint. With the thermo pane, storm windows will not be required for winter operation, and will improve the efficiency of the air conditioning system. This also eliminates the need to remove the screens in order to install storm windows.

**Screens** are made of plastic for hard wear and easy maintenance. Clean with a damp cloth. Note: They will melt at the point of contact if touched by a cigarette.

**Vistaview Windows**, an exclusive Airstream feature, allow for interior lighting while maintaining privacy and are equipped with integral shades.

**Factory recommended awnings** give shade during trips and rallies. They are easy to operate and can be installed by your dealer.

The aluminum construction of your trailer creates a radio-shield and you will need outside antennas for perfect reception.

**Motorized TV Antenna:** An Auto Coupler enables you to utilize your T.V. antenna for AM-FM radio reception.

The controls are located on the curbside wall just above the arm rest. To raise the antenna, depress the up button and hold it in place until the red light goes off. The antenna is now ready for rotating to the desired position. Press the top of the rotating button and rotate the antenna until you get the best possible TV picture. If you go too far, press the lower portion of the rotating button and the antenna will move in the opposite direction. To stow the antenna, press the bottom of the rotating button and allow the antenna to rotate until the red light goes off. The antenna is now ready for lowering so press the "lower" button and hold it until the red light goes off again. You are now ready for travel.

# Floor Plans

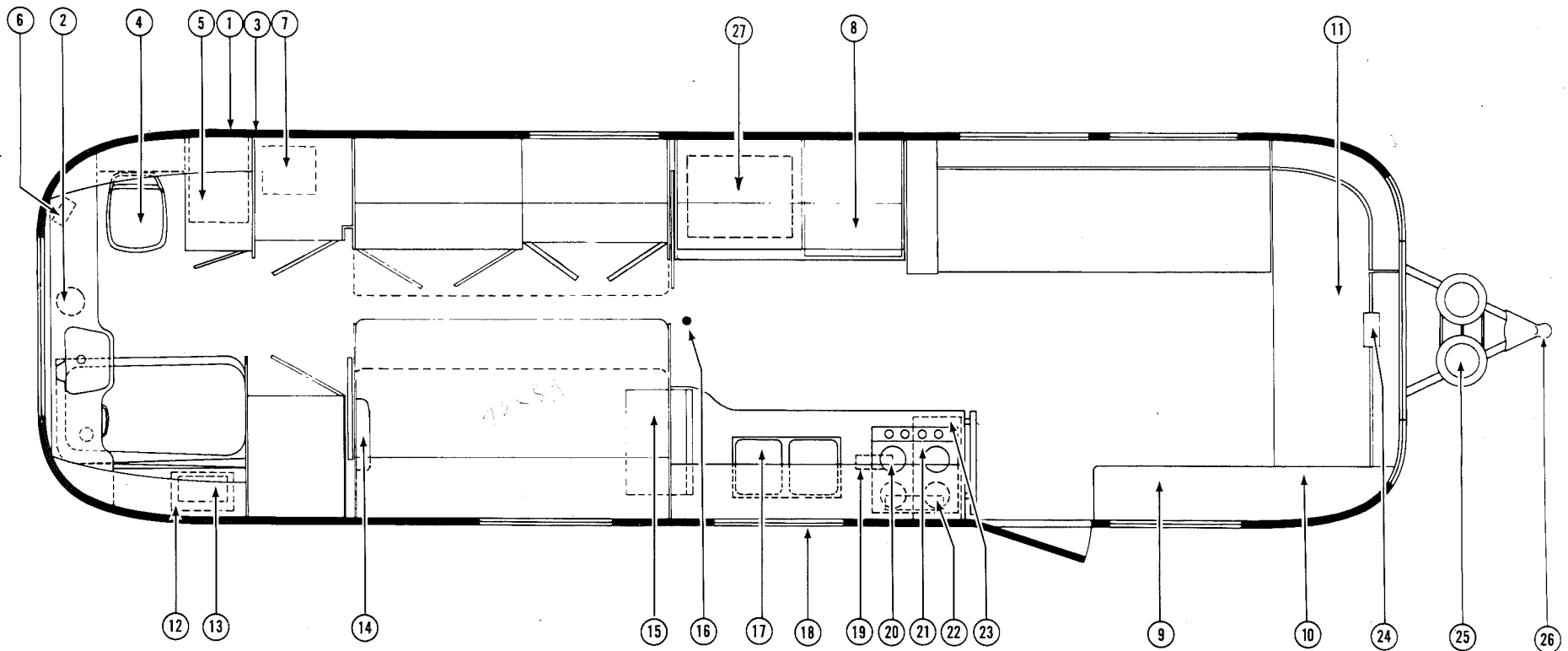

## Rear Bath

No. Description	Page No.	No. Description	Page No.	No. Description	Page No.
1. Electrical inlet-city .....	56	10. Stereo AM/FM Radio/Tape .....	34	19. Water pump .....	50
2. Waste outlet .....	52	11. Front lounge .....	32	20. Range exhaust hood .....	44
3. Water inlet-city .....	49	12. Battery .....	57	21. Range .....	44
4. Toilet .....	53	13. Univolt .....	56	22. Central control panel .....	33
5. Water heater .....	48	14. Bed light .....	38	23. Furnace .....	46
6. 120 volt circuit breaker panel .....	56	15. Oven .....	44	24. Clock and thermometer .....	34
7. Battery charger (optional) .....	58	16. Air conditioner .....	36	25. L.P.G. tanks and regulator .....	40
8. Refrigerator .....	41	17. Sink .....	36	26. Hitch .....	16
9. Table .....	35	18. Water inlet-tank .....	49	27. Micro wave oven .....	43

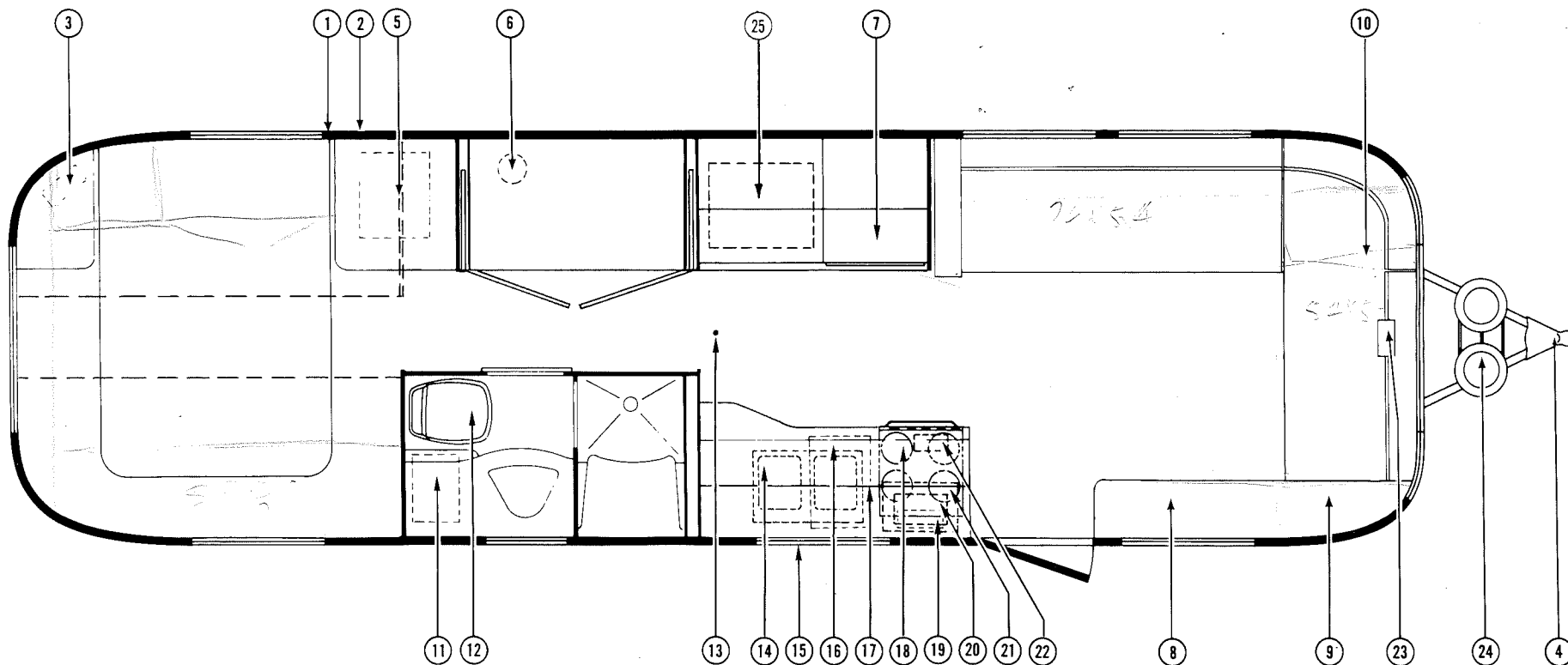

**Center Bath**

No. Description	Page No.	No. Description	Page No.	No. Description	Page No.
1. Electrical inlet-city .....	56	10. Front lounge .....	32	19. Central control panel .....	33
2. Water inlet-city .....	49	11. Water heater .....	48	20. Univolt .....	56
3. 120 volt circuit breaker panel .....	56	12. Toilet .....	53	21. Battery .....	57
4. Hitch .....	16	13. Air conditioner .....	36	22. Water pump .....	50
5. Battery charger (optional) .....	58	14. Sink .....	36	23. Clock and thermometer .....	34
6. Waste outlet .....	52	15. Water inlet-tank .....	49	24. L.P.G. tanks and regulator .....	40
7. Refrigerator .....	41	16. Furnace .....	46	25. Micro wave oven .....	40
8. Table .....	35	17. Range exhaust hood .....	44		
9. Stereo AM/FM Radio/Tape .....	34	18. Range and oven .....	44		



Lounge Into Bed 1.



2.



Bunk Bed

## Interior

The Airstream interior has been designed for comfort, convenience, durability and appearance. An understanding of the operational procedures and maintenance techniques of the interior appointments will add to your pleasure as well as the long life of your trailer.

To convert the Lounge into a bed, pull the back cushion down toward you onto the seat. Grasp the front rail of the seat in the center, lift it slightly and pull it out until it stops. Lay the back cushion down to finish the bed. To return, reverse this process.

The bunk beds (optional), located in the bedroom, serve as the bolster for the bed when not in use.

In order to place bunk into sleeping position:

1. Depress latch (A) located on the center back side of the bolster.
2. With latch depressed pull up on fabric loop (B) located on the center front bottom of bolster. This will allow bolster filler to hinge down.
3. Bring bolster filler up to horizontal position and attach both straps onto bracket on ceiling.

To lower bunk:

1. Release straps.
2. Rotate bolster filler into latched position.
3. Lower bolster down against wall.

Make beds in the usual way, using fitted sheets  $\frac{3}{4}$  bed size. The space behind the rear

cushion is ideal for storing bedding for both front travel lounges and side pull-out beds. An easy method of storing bedding is to remove and store pillows and then fold back the ends of the bedding neatly to expose about 2" of the mattress; then, starting from the edge nearest to you, roll up the bedding as tightly as possible towards the back wall. Raise the rear cushion to its normal position.

To make fixed twin beds, lift mattress slightly, pull it away from the wall and then tuck bedding in along wall. Note: Please do not launder mattress ticking; it has to be dry cleaned to prevent shrinkage.

Upholstery and drapes should be dry cleaned by a reputable dry cleaning establishment.



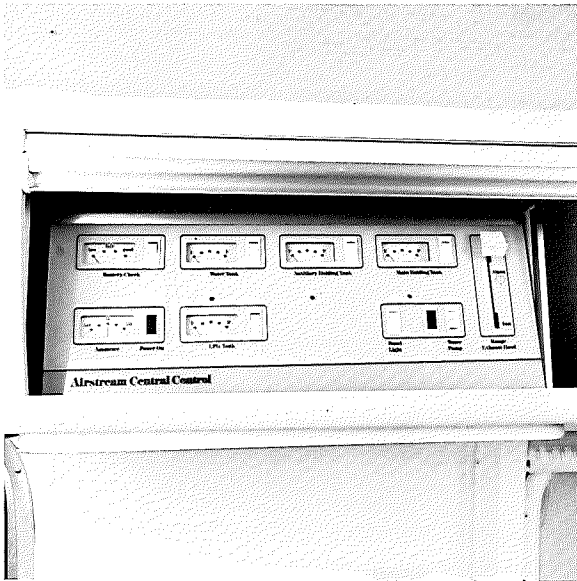

Central Control Panel

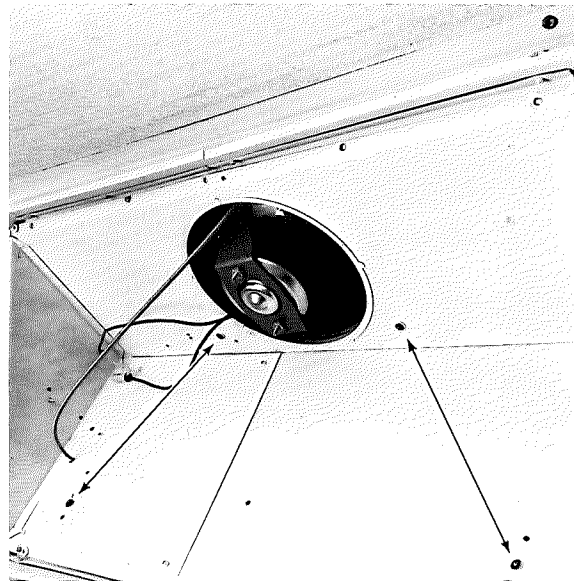

Central Control Panel Removal

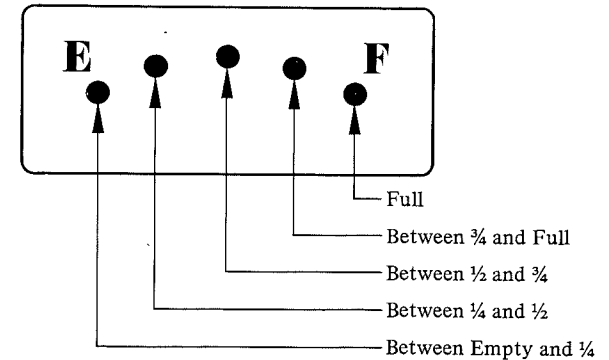

Water Tank and Holding Tank Gauges

The **Central Control Panel**, located in the galley roof locker of your unit, contains the necessary instrumentation to monitor your Airstream's systems.

The **Panel Light** switch lights the gauges.

The **Battery Condition Tester** has a switch which operates a meter indicating: Good, fair and low condition. (This meter does not indicate true battery state of charge while you are hooked-up to 120 volt city power.) When it shows low condition, you should take every reasonable step to conserve power by using as few lights as possible and switching off appliances. The battery should be charged as soon as practical with the tow vehicle charging system, trailer battery charger (12 volt

generator) or connection to 120 volt power.

The **Ammeter** indicates whether the trailer battery is being charged. If discharge is indicated, reduce your power usage. The **Univolt System** charges the battery only to the extent of any surplus over and above the electrical demands you make. The battery will not be able to recharge until the power usage is reduced. Therefore, before leaving on a trip, conserve power usage the night before to insure a fully charged battery.

The **Water Pump Switch**, when on, also lights the indicator light. For a complete discussion of the pump, please refer to page 50.

The **Water Tank**, **Main Holding Tank** and

**Auxiliary Holding Tank Gauges** indicate the amount of liquid in their respective tanks. Press the appropriate switch and the gauge will indicate in one of the five positions. (see diagram).

Before leaving the factory the tank level gauges are calibrated. Periodic recalibration may be necessary due to mineral deposits on tank probes. In rare cases, when the water tank has been filled with very pure water, as from a mountain stream, the gauge needle will not align with an indicator dot. This can be corrected by recalibration. To recalibrate any of the three tank gauges: fill the tank to its maximum capacity with water. Press switch and align gauge needle to the middle of the F dot by turning adjustment screw. This screw,

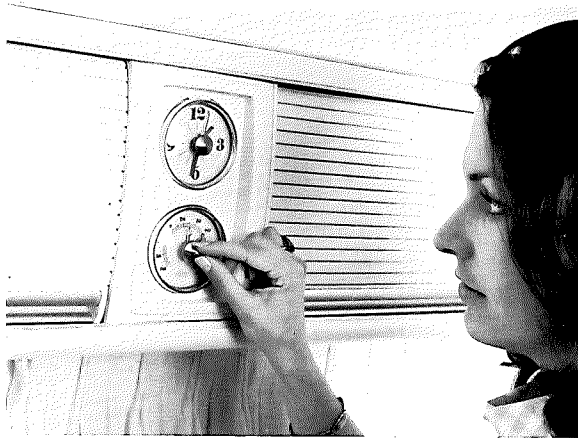

*Clock and Thermometer*



*Stereo Tape and AM/FM Radio*



*AM/FM Radio Fuse*

located in a hole directly below meter, may be turned with a narrow blade screwdriver. Accumulation of oxides, dirt, etc. may prevent alignment of needle with dot. In this case remove probes and scrape clean. Apply sealant to thread area only and replace probes. Care must be taken to keep probes free of sealant.

The **L.P.G. Gauge** indicates the amount of liquid in each tank. To check the level, move the tank selector switch toward the tank to be tested. The switch is located on the end shell under the front window behind the L.P.G. tanks. Then press the test switch near the L.P.G. gauge on the Central Control Panel and read the amount of liquid in the tank. This gauge will indicate any quantity between empty and full. It is calibrated at the factory and needs no further adjustment.

The **Power-On Light** will glow automatically when you are hooked up to city power. This light and the polarity warning light are your

checks on a proper 120 volt connection.

Access to the rear of the Central Control Panel is necessary for replacement of panel light bulbs and the Central Control Panel fuse. To remove Central Control Panel: remove 2 screws that secure the filter to the range exhaust hood housing and drop it out, remove 4 screws up inside range exhaust hood (see photo), remove range exhaust fan knob from lever by pulling straight out on knob, remove screws on side panel inside roof locker, and pull electrical connector apart.

The **Clock** is operated by a 'C' cell battery which will last from nine months to a year. Battery replacement and time reset is located at the rear of the clock.

The **Thermometer** indicates the outside temperature, and the minimum and maximum temperatures reached since the last setting. The lowest temperature reached the night before and the highest temperature reached during the day may be determined by re-

setting the pointers the night before. To reset the pointers turn the center adjusting knob on the bezel clockwise and counterclockwise until the pointers are against the temperature hand. **Do not apply excessive pressure against the temperature hand.**

A Motorola AM-FM stereo radio and a combination Motorola Stereo AM-FM radio with 8 track stereo tape player are available. The "fader" control allows the front speakers to be turned on by themselves, or the rear speakers by themselves, or any combination of front or rear speakers.

#### **To Operate the AM-FM Stereo Radio:**

1. Push on/off selector button in and radio/tape selector button in.
2. Push band selector button in for FM; out for AM.
3. Adjust volume control to desired listening level.
4. Tune in desired station. On FM stereo signals the FM stereo indicator will light.
5. Adjust tone control for desired bass or



Table Opening 1.



2.



3.

treble response. Adjust balance control for desired sound level between speakers.

#### To Operate the 8 Track Stereo Tape:

1. Push on/off selector button in and radio/tape selector button out.
2. Insert the 8 track cartridge into the tape slot (dial scale will open inward); insert cartridge open end first, label side up, until it is firmly seated in mechanism.
3. Adjust volume control to desired listening level.
4. Adjust tone control for desired bass or treble response. Adjust balance control for desired sound level between speakers.
5. To change programs, push the manual program selector. Each time the selector is pushed and released, the next program will play. Programs will play in succession (change automatically), and continuously, if manual selector is not pushed. The tape program indicator lights will light indicating which program is being played.
6. To turn tape player off, remove cartridge from tape slot, push the on/off selector off

(button out). Never leave a cartridge in the tape slot when player is not in use. Store tapes in a cool area with open end down. Protect tapes from dust and direct sunlight.

In time, oxide from recording tape will accumulate on the tape head and capstan shaft which can cause tape hiss and erratic operation. The more often the tape player is used, the more often it should be cleaned.

Clean the head with a cotton swab moistened with isopropyl alcohol. Do Not Use carbon tetrachloride.

To clean the capstan shaft, first turn on the motor by depressing the motor switch (next to the capstan shaft) with the eraser end of a pencil. Use a cotton swab moistened with alcohol on the shaft.

The fuse for the radio, or radio/tape is located behind the unit. To gain access to fuse, remove seat cushion and let unit hinge down. The fuse is secured within an inline fuse holder.

To open the table, lift the table into a horizontal position, depress latch and pull the folding leg down until it locks in position. To extend the table pull out on the latch underneath the table right next to the leg and lift the table and leg slightly off the floor. Now pull the extension frame and leg out as far as they will go. Release the catch on the extension table leaf and rotate it over onto the extended frame. By raising the leg the entire table can be slid forward and aft for your seating comfort.

To stow simply reverse the procedure and unlock the leg and drop the table to the wall.

The Bay Breeze Airconditioner has a high and low speed setting. To operate: (1) Close door, windows and ventilators. (2) Set thermostat to desired temperature (75° is normal). Do not make frequent changes. (3) Set the fan switch (left under thermostat) to "HI" position. (4) Set main switch (right under thermostat) to "cool." When the inside temperature is 90° or less and expected to continue, set speed to "LO." To shut down: Set main switch to "OFF."

Shut off to clean or replace the filter. Remove, brush off loose lint, run water through filter or move it briskly in soapy detergent water. Rinse thoroughly, dry completely and replace. The unit has a low voltage starter kit to help start under marginal conditions. Do not run under 103 volts.

Stainless steel sinks cannot be harmed by boiling water. However, salt, mustard, mayonnaise and ketchup will cause pitting. Stubborn stains will yield to paste made of water and slightly abrasive cleaner. Be sure to work in the direction of the polish-lines on the steel, to keep the original finish. Fingerprints are sometimes a problem. They can be minimized by applying a cleaner that leaves a film of thin wax: simply wipe it on and remove the excess with a dry cloth. After this, fingerprints can be wiped off with a soft dry cloth, or one moistened with a little wax cleaner. The surface should always be washed before wax is applied. Regular cleaning will prevent build-up of scale and film. Ordinary soaps or detergents are best for routine cleaning of the stainless steel sinks. Rinse thoroughly with warm water and wipe dry with a cloth to avoid streaks and spots.



*Air Conditioner Ducts and Filter*



*Wardrobe Catches*

For further information on galley equipment refer to page 41 for the refrigerator and page 44 for the range and oven.

All the drawers are removable allowing you storage flexibility and ease of packing and unpacking. Wardrobe catches are self-locking and they may be opened by sliding the touch plate away from the door opening.

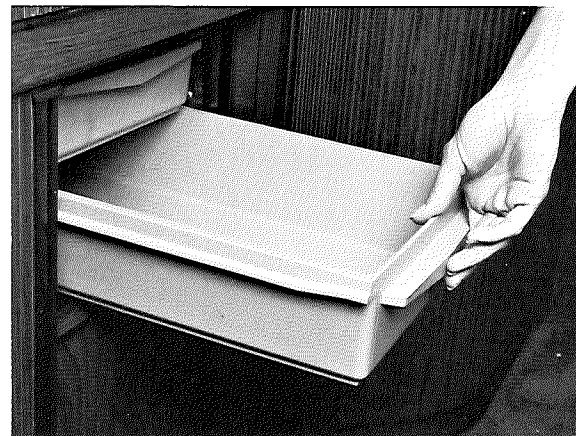

*Storage Drawers*



*Space Locker*

A **space locker** attached to the roof lockers is available for additional storage space for bedding, etc. in the bedroom.

When attaching wall hung improvements, like hooks for clothing, bookshelves and extra towel racks, secure with half-inch No. 8 sheet metal screws ~~(4444)~~ with flat binder heads, make holes in the aluminum inner walls with a small hand drill (No. 30 drill bit).

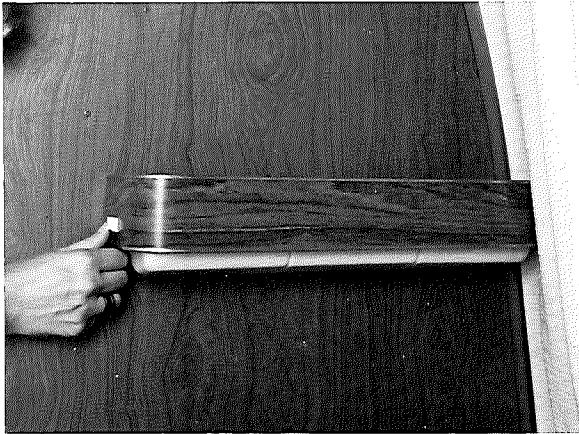

*Bed Lights*

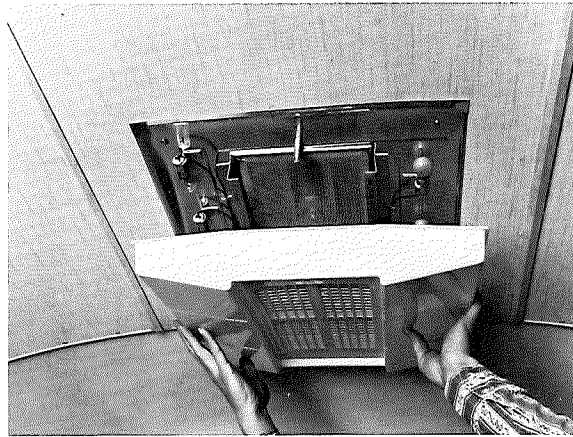

*Ceiling Light Fixture*

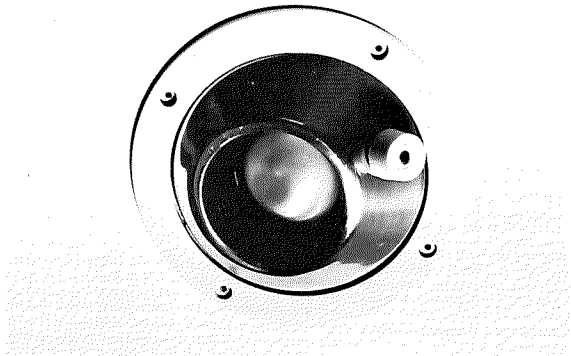

*Area Lights*



*Below Bed Storage*

**Bed-lights** are operated by a switch on the side. To replace bulbs snap the lens out by squeezing gently the long side of the lens until it drops out of the fixture. **Area lights** have switches on the rim.

**Ceiling light fixtures** are incorporated with the ceiling fresh air vents. To operate the lights turn the forward control knob clockwise; first position 2 lights, second position 4 lights, third position 6 lights, fourth position off.

To remove the lens and replace the bulbs, unscrew the forward control knob and nut. Remove the screw from the aft control handle. This will release the lens.

The fresh air vents are operated by the aft control handle. Turning clockwise will raise the vent and at the maximum extension vents with fans will automatically turn on. For maximum air without fan, open until fan starts and back up just enough to turn fan off. Turning counterclockwise will close the vent.



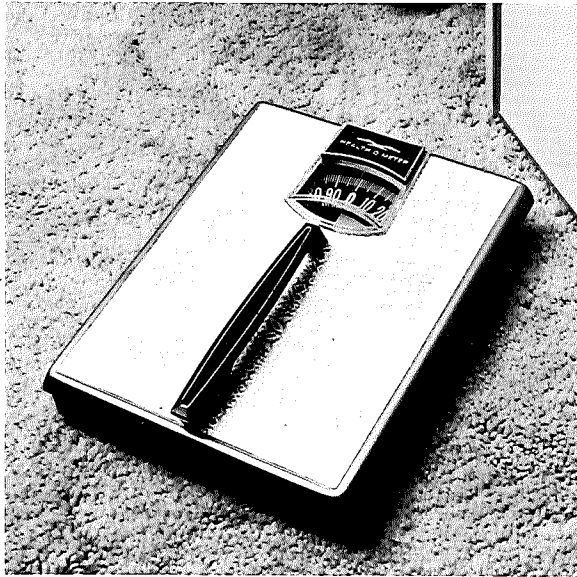

*Slide Out Scale*

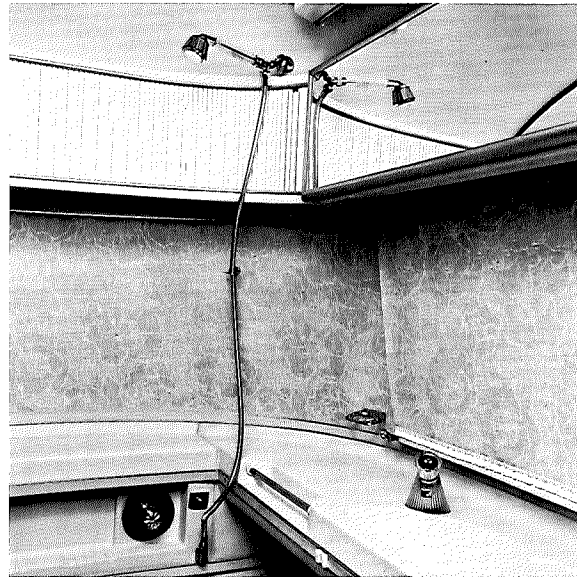

*Rear Bath*

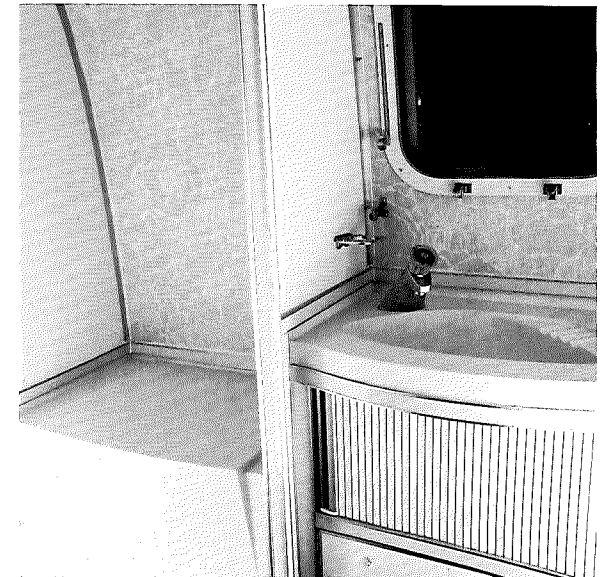

*Center Bath*

Airstream vents are designed to allow air circulation while still keeping out rain and can be used in any weather. Screens should be removed for periodic cleaning.

The below bed storage is available on fixed twin and double models for added storage of bedding and linen or fishing and hunting gear.

A slide out scale is located in the rear wardrobe on both bath models. Slide scale vertically out of the track and place on floor.

A 12 volt two-tone door bell is installed on the forward side of the main door with the chimes located under the credenza.

The hanging wardrobe (optional), located over the foot of the bed, increases storage for short items like shirts, blouses, skirts and short coats.

The bathroom exhaust fan in rear bath models is in the bathroom wardrobe wall left of the toilet and is operated by a switch under the roadside roof locker.

In center bath models the fan is located behind the toilet and is operated by a switch located to the right of the toilet. Complete toilet instructions are on pages 52-54.

The lavatory bowl, counter top, tub or shower pan in your Airstream bathroom are made of a special ABS long-wearing, light weight, high strength plastic material. When cleaning, use soap or detergent only — never use scouring powder.

The telephone shower head is designed to give maximum flexibility in usage and provide for water saving techniques when using your trailer on self-containment.

When using the shower head, it should be held in the hand and moved about the body. Normally the best water conservation procedure is to wet the entire body and then turn the water off with the push button at the shower head. Apply soap, lather thoroughly, then rinse the soap off. The shower can be turned on and off without disturbing the hot-cold adjustment. The telephone shower head is also used to fill the tub for taking a bath.

The medicine chest is behind the mirror in the rear bathroom. The 120 volt and 12 volt outlets are located below the medicine compartment on the roadside of the unit. The medicine chest in the center bath is to the right of the lavatory with the 120 volt and 12 volt outlets located behind the mirror.

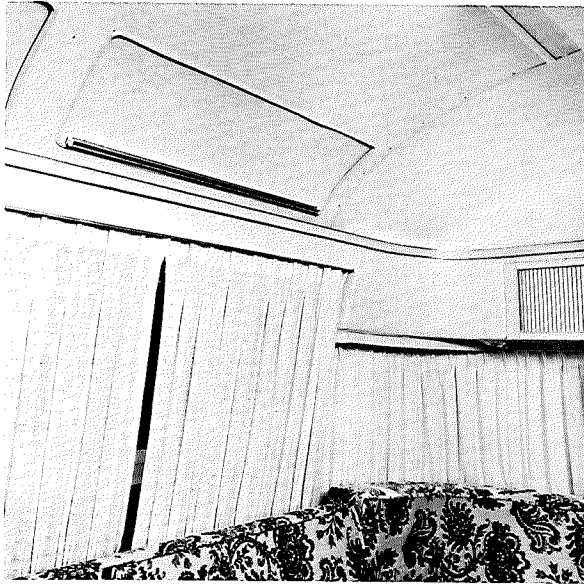

*Indirect Fluorescent Lighting*

The light in the rear bathroom is operated by a switch under the roadside roof locker. The light in the center bath is operated by a switch at the top center of the base. To change bulbs, squeeze the lens at each end and pop it out.

The living room has an indirect fluorescent lighting system. It features a solid state ballast and three position switch for two levels of lighting. The first position is low level, second position is high level and third position is off and bulb replacement. The switch is located under the front roof locker on the curbside. To replace bulb turn switch to off position, remove electrical terminal from each end and slip off each elastic retaining loop. The bulbs are wired in series; therefore, if one bulb burns out the other will not operate.

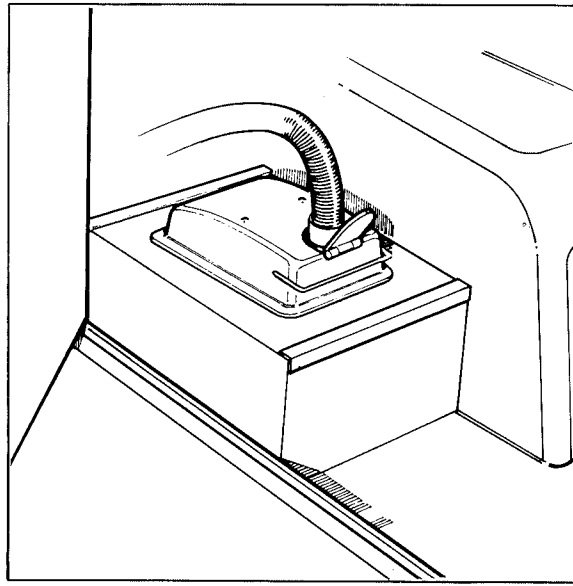

*Vacuum Cleaner Hose & Outlet*

A fire proof safe deposit box is located under the front lounge. To gain access, remove curved bolster, pull back roadside end of front lounge seat cushion and remove small access door on bed top.

The vacuum cleaner is located in the storage cabinet below the Micro Wave oven. To start the unit, raise the flap on the outlet and insert the hose with a slight twist. Make sure the dust bubble is connected to the hose before using. To stop the unit, simply remove the hose from its outlet.

To open and empty the dust bubble, hold it over a trash container and twist the lower lid carefully. Tap the two halves to release any dirt trapped on the filters. The dust bubble can also be rinsed out after removing both upper and lower filters.

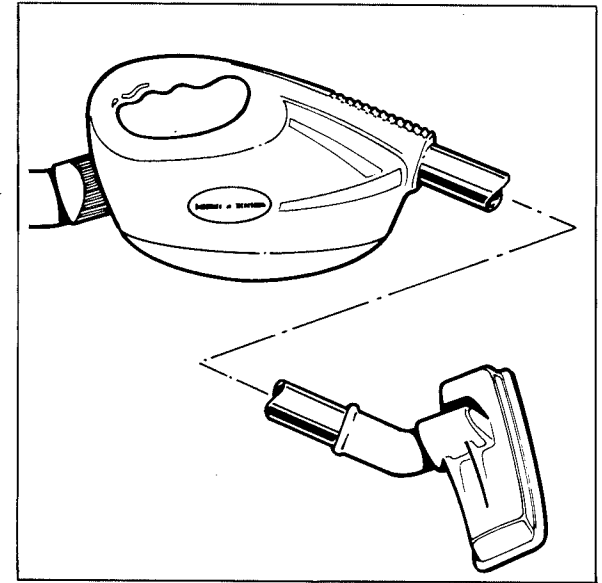

*Vacuum Cleaner Dust Bubble*

To remove the filters, remove the lid and grasp the large outer red ring in the upper half of the bubble. Pull it gently toward you until free. Lift out the small inner red ring from the center of the bubble. Remove the lid filter ring by pulling gently. To reposition the filters reverse this procedure. When properly positioned, the large outer red ring should rotate freely on the flange.

# L.P.G. System

Your Airstream is equipped with two tanks for LPG (Liquid Petroleum Gas). LPG burns with a clean blue flame and produces more heat than natural gas. There are two basic types of LPG in common usage: **Butane** and **Propane**. Butane is widely used where temperatures are normally above freezing the year round and Propane is used where subfreezing temperatures are common, since Butane freezes at 32°F as compared to -40°F for Propane. All of the orifices in your Airstream LPG appliances are of the universal type which will burn either fuel.

How long a full tank of gas will last is dependent on usage. In cold weather when you are using the furnace, large amounts of hot water, and are doing extensive cooking, you will naturally use more than you will in warm weather when you may do limited cooking. On the average, with normal cooking and other appliance use, you can probably count on three weeks service from each 28-lb. tank.

The Excella is equipped with an **Automatic Gas Regulator**. Both tanks are connected to this regulator and are turned on. Gas is drawn from only one tank at a time and when the tank being used is depleted the regulator automatically switches to the full tank. An indicator on the regulator points toward the tank being used to give you a visual reminder when one tank is empty. Additionally a tank gauge is on each tank indicating fuel level. The empty tank can be removed for refilling

without disturbing the tank being used. Simply close the tank valve, disconnect it, have it filled and reconnect.

To remove the gas tanks, disconnect the tubing nut with a wrench and loosen the bar handle which holds the tanks in place. The tubing nut has a left hand thread so be sure to always turn it clockwise to loosen and counterclockwise to tighten. When replacing a tank, connect and tighten the tubing nut before clamping it in place.

If you have allowed both tanks to run out, air may have gotten into the lines. In this event, the air must be forced out through the lines by gas pressure before you will be able to light the pilots. Hold a match to the pilot of the appliance closest to the tanks until it lights and stays lit. Then move to the next closest, etc. For complete appliance operating instructions, refer to pages 41-48.

Note: In some states it is illegal to leave the gas tanks turned on while towing a trailer.



*L.P.G. Tank Gauge*

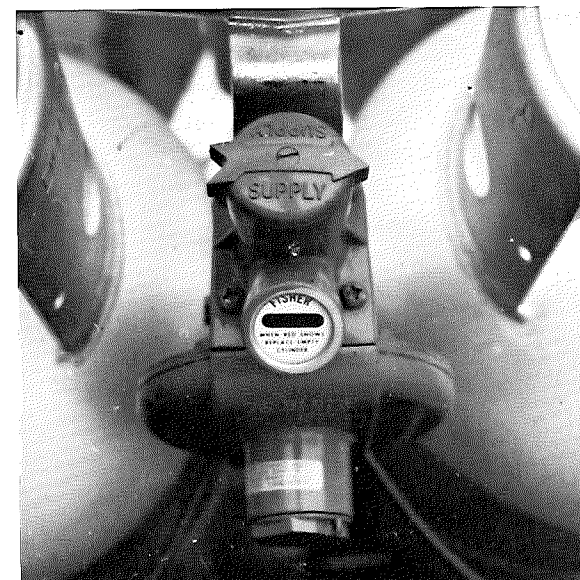

*Automatic Gas Regulator*



# Refrigerator

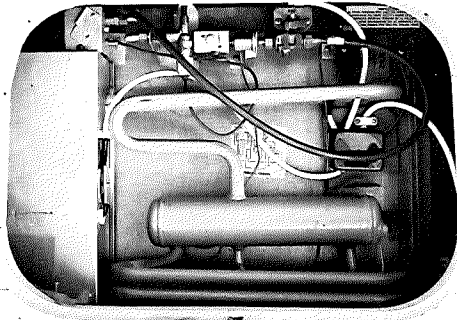

*Outside Access Compartment*

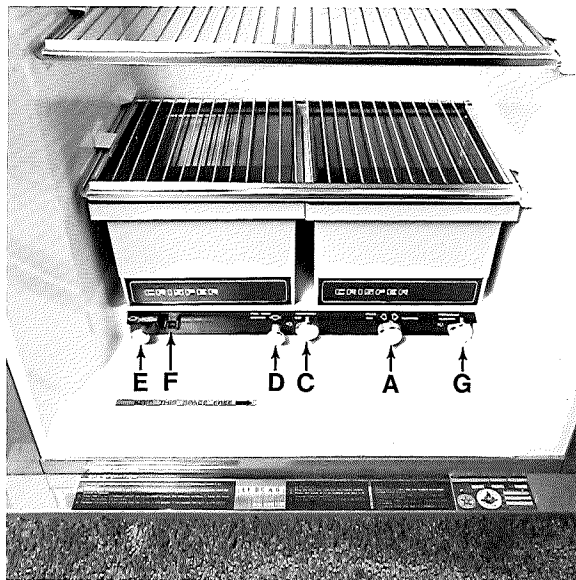

*Controls Inside Refrigerator*

Your Airstream is equipped with an A.G.A. approved Dometic gas-electric refrigerator. These are the finest refrigerators available for trailer use and will give you many years of faithful service.

For best operation of this refrigerator it is important to level your trailer. When parking try to avoid having a strong wind blowing directly against the vent outlet for most efficient operation.

Controls for both Gas and Electric operation are located inside the food storage compartment, at the bottom of the unit, and in the Outside Access Compartment. See photos.

For Gas Operation, follow these instructions:

1. Open refrigerator door, all controls for gas operation are located at bottom of unit.
2. To start the refrigerator turn the valve knob (A) to gas position. The gas valve is now open and the electric circuits are not in use. Set thermostat knob (C) to setting #4.
3. Pull knob (D) of the automatic pilot, and keep it out for 15 seconds. Press in knob (E) of the piezo lighter. The pressing may have to be repeated.
4. After the burner is lit, which can be seen through reflector window (F), keep the knob (D) pulled outward for an additional 15 seconds.
5. Release the knob (D) and check that the burner is operating.

If the burner is not operating, repeat the lighting procedure.

After a replacement of a gas bottle or a long shut-off period the gas lines are likely to be filled with air. In such cases the lighting procedure has to be repeated until the air is pushed out of the lines and the gas has reached the burner.

As soon as the required cold temperature inside the cabinet is reached, the thermostat cuts the burner main flame to the by-pass flame sufficient to keep the safety valve open during gas operation. During electric operation the thermostat cycles the flow of the electrical current to maintain the set temperature.

Incorporated in the burner bracket is an automatic flame failure device which allows gas to pass only when the burner is lighted, keeping the thermocouple hot. Should the flame be blown out, the thermocouple will cool and the device will cut off the flow of gas to the burner.

The refrigerator is fitted with a piezo lighter which does not require flint.

For Electric Operation, follow these instructions.

1. Open refrigerator door and outside access compartment door. Outside access doors are opened by unlocking and turning the handle 1/4 turn counterclockwise. Controls

for electric operation are located in both areas.

2. To start the refrigerator turn the valve knob (A) to the off position.
3. Plug the electrical cord into the 120 volt outlet (B) located on the back wall of the storage compartment below the Micro Wave oven.
4. Press knob (A) in, until it stops, then turn to electric position.
5. Turn the electric thermostat knob (G) to setting #4.

For best operation even during extended stays in parks your unit should be periodically run on gas.

The refrigerator has automatic thermostatic control of the temperature in the food storage space. The gas thermostat (C) controls the temperature during gas operation, while the electric thermostat (G) controls the temperature during electric operation. Be sure to make the temperature setting on the correct thermostat.

Your Dometic incorporates a unique, fully automatic defrosting device for the general food storage compartment, which eliminates the necessity for manual defrosting at frequent intervals normally associated with most conventional refrigerators in the medium size range. Furthermore, the time interval of each defrosting cycle, and the frequency, have been so arranged that during defrosting there is no noticeable effect upon the temperature of the foods stored in the refrigerator, and the frozen food storage conditions can be maintained at all times in the frozen storage

compartment.

When cleaning, remove all food and clean the interior and all other plastic parts with warm water, and mild detergents. Never use abrasive or caustic cleaning powders, polishes, cleaning paste, gasoline, turpentine or other solvent type cleaners. Use a damp cloth for cleaning and finish with a soft dry cloth.

When the refrigerator is to be out of operation for some time, always leave the door slightly open or place a pie tin of barbecue charcoal on the shelf.

The following are some trouble shooting tips for emergency use only. They relate to gas operation and should normally be done by the dealer.

**Problem: Flame goes out. The thermostat is out of adjustment. To adjust it, turn the dial to "zero". If the flame does not go down to the "low" by-pass setting, follow this procedure:**

1. Unscrew the large cap screw at the rear of the thermostat and remove the valve. Clean the seat and valve, and replace.
2. If procedure (1) does not correct the problem, adjust the set screw out (in counterclockwise direction) until the flame goes down to the "low" position.

If the flame keeps going out when the dial is turned to (O), remove and clean the by-pass screw which is located as shown in the diagram above.

**Problem: Burner does not light. Remove and**

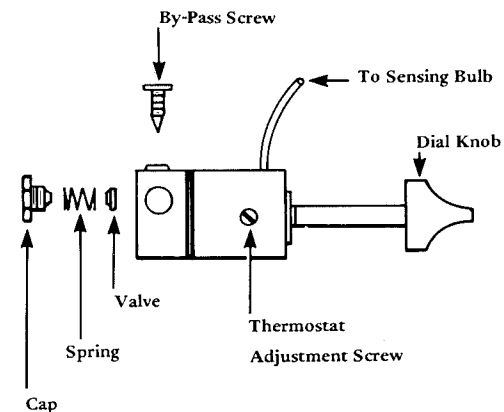

Thermostat

clean the burner barrel, and/or check the gas supply.

On gas refrigerators, the flue will require cleaning at least every six months. To do this, it will be necessary to gain access to the back of the cabinet. When cleaning the flue proceed as follows:

Unscrew the burner housing, then lift out the baffle on its support wire from the top of the boiler tube. From the top, clean the flue with a suitable flue brush. Also clean the baffle, before putting back in place. An obstruction in the flue will reduce or stop flue draft. Flue obstructions will cause odors outside refrigerator, slow freezing and higher cabinet temperatures.



Micro Wave Oven

## Micro Wave Oven

Your Excella is equipped with the Litton Industries, Atherton Division, portable Micro Wave Oven. Airstream dealers cannot service or make adjustments to the oven. This must be done by an authorized Litton Industries dealer. If you ever have problems with the oven check the local telephone directory for the nearest dealer.

The operation of your electronic oven is as simple as 1, 2, 3:

1. Press the **ON/OFF** button. This starts the cooling fan and cavity lights. Only 5 seconds are needed for warm-up.
2. Depress thumb latch on handle, open door and place food item inside. Set timer for desired setting. **NOTE:** The first half of the timer covers 4 minutes in short second

increments. To set timer on a short time, e.g., 15 seconds, first turn to 1 minute then back to 15 seconds.

3. Press the **START** button to begin the cooking process. **NOTE:** When you open the door, cooking will stop automatically until you close the door and re-press the **START** button. Your timer will maintain the proper time setting.

We recommend that you try one of the following to acquaint you with this exciting new idea in cooking:

1. Easy bacon! Place 3 strips of bacon over paper toweling on a paper plate. Cover with several paper towels (to prevent spatter). Cook for 2½ minutes.
2. A quick apple! Wash and core apple. Fill center with a mixture of ½ tablespoon butter and 1 tablespoon brown sugar. Place in a large custard cup or desert dish. Cover with wax paper and cook for 2 to 2½ minutes.
3. Pouch of frozen vegetables! Place frozen pouch in oven. Cook (thaw) for 2 minutes. Puncture a small hole in the top of the bag (for steam to escape). Continue to cook for 2 minutes longer.

Please read your cooking guide carefully. It will help you learn about your new Litton Electronic Oven quickly.

### IMPORTANT

#### Safety and Maintenance Instructions.

Your new Litton Micro Wave Oven has been carefully designed and thoroughly tested to meet exacting safety standards. However, it is

important for you as a user to observe certain precautions and care in utilizing your Litton oven for maximum performance and safety. The door on your oven has been carefully designed to contain the micro wave energy; therefore, it is important that you observe the following:

1. Do not operate the oven with any object closed between the door and the oven face.
2. Do not operate the oven if there has been any damage to the oven face or door including loose or broken hinges or latch, or if the door does not close firmly against the oven front.
3. Do not attempt to defeat the interlock switches. They are there for your protection. You will note that upon operating the door latch while the oven is in the cook cycle, the oven cook light will go out. If the light does not go out, the front interlock switch is not operating properly. In such case, do not operate the oven until the interlock switch has been repaired.
4. Remember that it requires considerable electrical power to operate the micro wave oven (15 amps). Operation of other 120 volt appliances should be kept at a minimum when operating the oven.

The door enclosing the micro wave oven can also be used as additional counter space.

Your new oven requires very little maintenance except for cleanliness. Do not allow grease, soil or splatter to build up on the door seal to the oven cavity. Litton maintains trained service technicians in all principal metropolitan areas. It is suggested that these authorized service agencies be utilized for proper repair and adjustment of your oven.

# Range/Oven

Your Airstream is equipped with a Magic Chef gas range and oven. The following are some hints on how to keep them operating at their best.

The range is equipped with coaxial orifices for use with LPG. The flame will be approximately  $\frac{1}{2}$  inch long. Do not attempt to adjust gas to burner. The orifices have no adjustment.

Air shutters on top burners are to be adjusted so that each cone of the flame is separate and distinct and appears as illustrated in the figure to the right. Air shutters set too far open will cause the flame to lift away from the burner head and it will be difficult to light. If the air shutters are closed too much, the flame will look hazy and the distinct cones will be missing.

Problem: Flame lifts off ports—Too much air.  
Problem: Soot formations — Not enough air.  
Problem: Flame flashes back into air mixture chamber — Too much air in proportion to gas. Slightly decrease air.

Problem: Orange flame; caused by small filings in new burners or dust in air—Clean burners.

Problem: Burner fails to light — Usually too much air.

Note: To adjust air-gas mixture, rotate the sleeve behind the burner control knob. Decrease air by closing the opening, and increase air by opening it.



*Range Rear Bath*



*Range Center Bath*



*Oven Rear Bath*

Adjust the top pilot so that the tip of the flame is just over the edge of the inner cone. The burners should light within 4 seconds. If lighting is difficult, refer back to the previous step.

Never allow the top cover to be closed while the range is in operation, as this will extinguish the flame and permit gas to escape into the trailer.

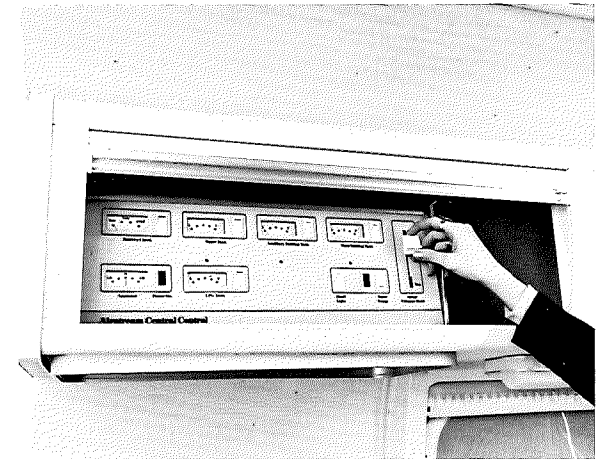

*Range Exhaust Hood*

The range exhaust hood provides venting of cooking heat and smoke from the trailer. To operate, pull lever (A), on right hand side of central control panel, down. This will open the shutter and turn on the switch for the power fan. Clean the filter regularly with warm water and detergent. To remove the filter, remove the two screws that secure it to the housing and let it drop out. Keep the vent housing clean from grease and dirt by frequent washing.

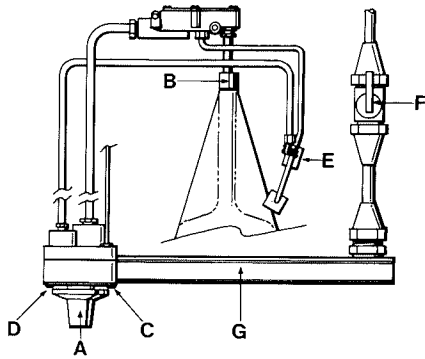

Combination Range and Oven Controls

**Note:**

The range gas line shut-off valve (F) located under the top of the range at the right end of manifold pipe (G) must be turned off when towing the trailer, when changing the gas tanks, or if the gas supply is turned off for any reason. Be sure oven pilot light has been relighted as soon as range shut-off valve is turned on.

The thermostat on your oven does not have a by-pass setting. It will cycle off and on at all temperature settings except broil. No by-pass adjustment is necessary.

**Oven Section:**

The Thermostat Control Knob (A) is combined with the constant pilot shut-off. For normal use: turn only between "OFF" and "BROIL." When traveling, turn to "PILOT OFF." Relight only when you want to use the oven, by turning from "PILOT OFF" to "OFF" and lighting with a match.

The air shutter (B) on the main burner is to be adjusted so that each cone of flame is separate and distinct, as illustrated.

**Constant Pilot Adjustment:**

1. Remove Control Knob and Bezel (A).
2. Using a screwdriver, turn slotted red-colored Constant Pilot Selector (C) to LP position. When the slot is in the vertical position, the Selector Cartridge is in the "OFF" position.

**Heater Pilot Adjustment:**

1. Replace Control Knob and turn to the 300 degree setting on the Control Knob Dial. This opens the thermostatic valve in the thermostat and allows gas to flow through the Heater Pilot Tube to the Heater Pilot.
2. Remove the Control Knob.
3. Using a screwdriver, turn the slotted green-colored Heater Pilot Adjusting Cartridge (D) in either direction until the pilot flame just envelopes the Temperature Responsive Element (E).
4. Replace Bezel and Control Knob.
5. Make any air shutter adjustments for oven burner flames.

**Important:** Your oven is equipped with a safety ignition that requires a minimum of 30 seconds to operate after turning the oven control knob on. The oven pilot may be slow in lighting due to air in the gas lines.

**Cleaning instructions:**

1. The main top has been hinged from the back so that it can be raised for cleaning around the top burners.
2. When cleaning the top burner heads, care should be taken that all ports are opened up with a toothpick afterwards.
3. Spill-over or spotting in the oven or broiler are more easily cleaned when removed promptly after they occur. Never wash porcelain when warm. Never use cleaning powder containing grit or acid. When oven bottom is replaced after cleaning and servicing, be sure that it is locked in place. The front return flange on the oven bottom must hook under the side support angles to prevent warping.

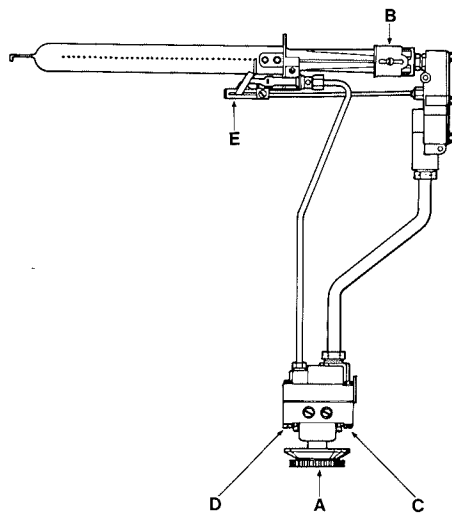

Wall Oven Controls



Separation of Flame into Distinct Cones

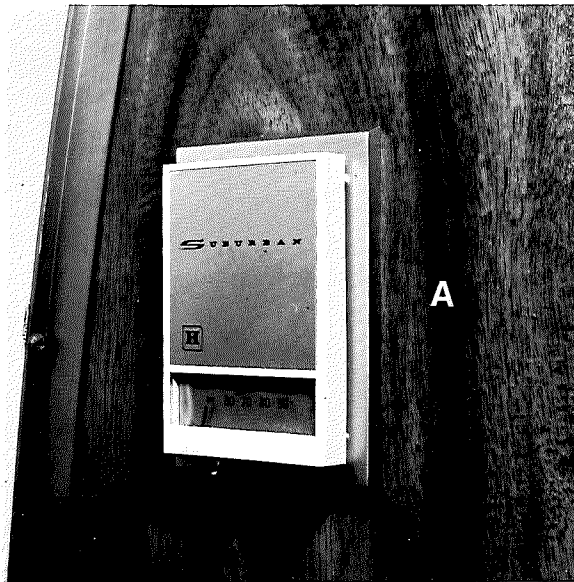

*Furnace Thermostat*



*Manual Gas Valve*

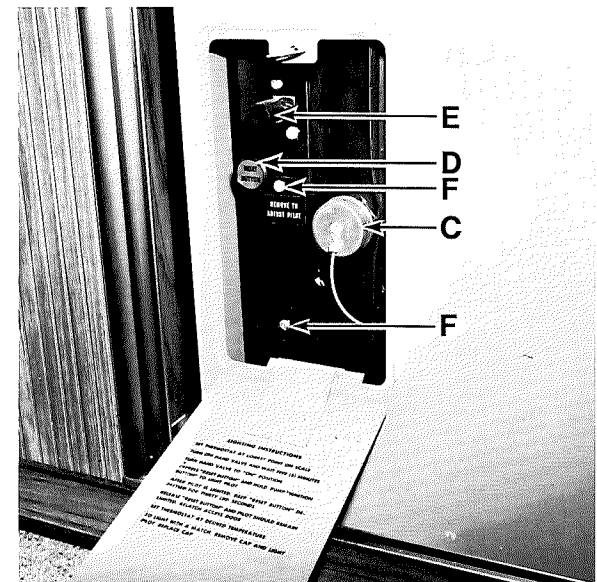

*Furnace Controls*

# Furnace

The Airstream furnace is an American Gas Association approved Suburban unit designed specifically for travel trailers. It has a sealed combustion system with a dual blower for maximum air circulation. One blower circulates room air while the other draws in air for combustion. The adjustable louvered heat registers control warm air flow while cold air returns through the galley cabinet toe kick opening.

The heat duct system also circulates warm air around the holding tank, water tank, and one-stop-service center, a vital feature when operating in below freezing weather.

The Suburban furnace is thermostatically controlled. When the thermostat calls for

heat, the blower starts and only after it has reached nearly full speed will the burner light. After the temperature set on the thermostat is reached the blower will continue to run for a short time removing most of the remaining heat from the furnace as well as forcing the combustion gases from the heat exchanger. To turn the furnace off for an extended period of time turn the thermostat (A) to its "OFF" setting and turn the manual gas valve (B) to its "OFF" position (perpendicular to the gas line). Operating instructions are printed inside the furnace door.

Trouble-free operation of the Suburban furnace will depend on your adherence to recommended operating procedures and precautions. Corrections of possible malfunctions

presented here will be helpful in an emergency situation, but servicing should be done by a dealer. One note of caution regarding flue gases: they are vented from the furnace to the outside of the trailer through a vent in the outside wall. Do not in any way obstruct this vent by placing clothing or other flammable material on the vent assembly. Check it often to make certain it does not become clogged.

The furnace may be lighted with the electromagnetic lighter or a match.

1. Set the thermostat (A) to the "OFF" position.
2. Unlatch the furnace door, and open it.
3. Turn on the manual gas valve (B).
4. Remove the lighter hole cover (C).

5. Depress the reset button (D) and hold it in.
6. Light the pilot by pressing quickly on the ignition button (E), or with a match.
7. After the pilot is lit, keep the reset button depressed for thirty seconds.
8. Release the reset button and the pilot should remain lit.

If the pilot goes out, repeat the above steps keeping the reset button depressed for a longer period of time. The pilot may not light immediately due to the presence of air in the gas line. It may be necessary to hold the reset button in for a minute or more before the pilot ignites. Replace the lighter hole cover (C) as soon as the pilot is lit and close the front access door and set the thermostat (A). If the furnace has just gone out, turn the manual gas valve (B) off and wait 5 minutes before attempting to relight the pilot.

Differences in pressure between the room air and the outside air may cause a strong draft to come through the furnace once the lighter hole cover is removed. Opening a window or the door on the same wall as the furnace while lighting the pilot will prevent this from happening. Differences in inside and outside temperature will have no effect on furnace operation once the lighter hole cover (C) has been replaced.

**Adjustment of Main Burner (Primary Air):**  
Set the furnace into operation by advancing the thermostat and allow to run until it reaches near-maximum operating temperature. Observe the main burners through the lighter hole cover (C). The flame should be without a trace of yellow and be "sitting" on

the burner. As the furnace was tested at the factory before shipment, it may be found that the primary air is already in proper adjustment. However, adjustments may vary from one location to another due to differences in elevation and in characteristics of the fuel gases.

If the flame burns yellow or "lifts" off the burner, it needs adjustment. Take out the screws retaining the rectangular cover plate (F) and lift the plate off. Inside the opening is a threaded rod with the visible end slotted to receive a screwdriver. By turning the rod you will adjust the position of the main burner air shutter. This air shutter should be adjusted to the point where a slight trace of yellow remains in the tip of the flame. Replace the cover and check that the yellow tips have now disappeared. **Caution: the lighter opening cover and the primary air adjustment cover plate must be in place for proper operation of the furnace.**

The most common cause of furnace failure is pilot outage, the inability of the pilot to stay lit unless the reset button is depressed. The trouble is usually in the thermocouple, which is located inside the cover plate near the pilot light. Check to see that the end of the thermocouple lead is screwed firmly into the safety pilot valve and that the joint is clean.

The furnace can be used to circulate air during hot weather by shutting off the gas valve (B) and turning the thermostat (A) up higher than the temperature in the trailer. **Return the thermostat to the "OFF" setting whenever the furnace is not in use.**

When the humidity is high inside your trailer and you wish to remove moisture, open a roof vent and turn on a vent fan or open a window slightly for cross ventilation.



# Water Heater

The Bowen Gas Water Heater is equipped with a Robertshaw 100% shut-off safety valve which shuts off the gas supply if the pilot flame is extinguished or the water temperature becomes excessively hot. It is lighted and serviced from the outside through an access panel at the roadside, rear, of the trailer.

## Procedure for lighting or relighting:

1. Be sure the water heater is filled with water. Open the hot water faucet at the sink and when the water flows, the heater is full.
2. Turn the gas cock knob (A) to the "OFF" position and the temperature indicator dial (B) to the lowest temperature position.
3. Wait sufficient length of time to allow gas, which may have accumulated in the burner compartment, to escape (approximately five minutes).
4. Turn gas cock knob (A) to "PILOT."
5. Depress and hold the red reset knob (E) and push the lighter (D) in and turn until the pilot flame ignites. This may take several turns of the knob. Or you may light it with a match.
6. Keep the reset knob depressed for one-half minute after the pilot flame ignites.
7. Turn the gas cock knob to "ON."
8. Set the temperature indicator dial to the desired water temperature.
9. To shut down the water heater, turn the gas cock knob to the "OFF" position.

## Pilot Flame Adjustment.

If the pilot flame does not have a small orange

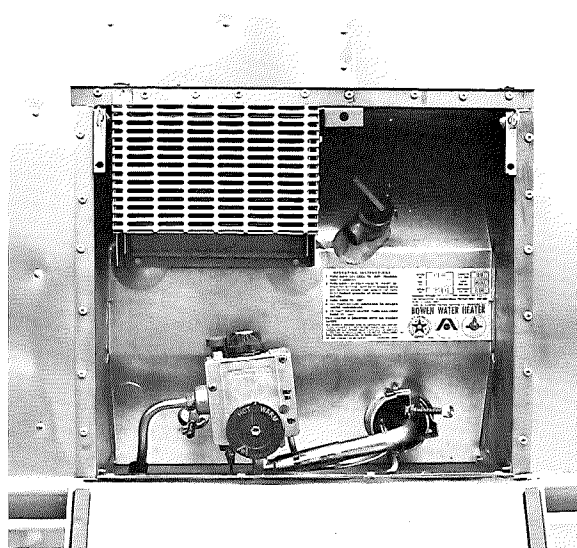

Water Heater Access Panel

tip, the pilot is not getting enough gas. The flame should be about 1/4 inch in vertical height when the water in the tank is cold and the burner is off, 1/4 to 3/8 inch in horizontal length when the tank is warm.

A large orange flame indicates excessive gas supply, which will result in short pilot life and early replacement. The pilot has been properly adjusted at the factory and should operate with a blue, orange tipped flame enveloping the pilot thermocouple. Removal of the pilot adjustment cap (C) in the lower right corner of the control will reveal the pilot adjustment screw. Turning this screw clockwise reduces the flow of gas to the pilot (blue flame) and counter-clockwise, the gas supply will increase (orange flame). Always replace the Pilot Adjustment Cap to prevent gas leakage.

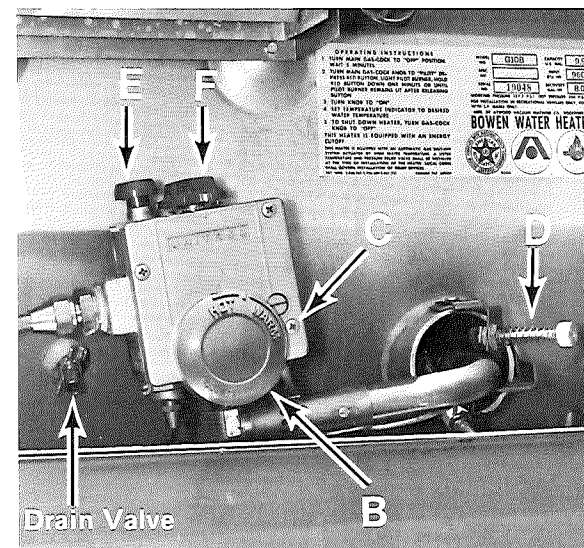

Water Heater Controls and Drain Valve

## Air Shutter Adjustment.

All fuels depend upon air (oxygen) to give them proper burning characteristics. A yellow, smoking flame indicates a lack of air and a noisy hard blue flame indicates too much air. The air shutter slides back and forth along the burner tube and is held in place by a small shutter adjustment screw (D). Loosen the screw for adjustment. A good method of adjusting the air shutter is to slide the shutter to the right until yellow tipping occurs on the main burner flame (not the pilot) and then slowly slide the shutter to the left until all signs of yellow tipping are gone. When proper adjustment has been obtained, tighten the screw holding the air shutter. The outside access door must be kept firmly locked for proper operation.



# Water System

The Airstream Water System provides full service both when the trailer is self-contained, or when city water is available. Water heater capacity is 10 U. S. gallons. The water tank stores 45 gallons of clean fresh water for all your needs.

When self-contained, the Water Pump should be turned on. The switch is located on the Central Control Panel in the galley roof locker of your Airstream. The Water Pump will run whenever a faucet is opened, and will shut off whenever a faucet is closed. It will deliver 3 gallons per minute under constant pressure.

**Note: The Water Pump must be turned off when hooked up to city water supply and when you leave your Airstream unattended.**

For city water supply, move the water hose reel lever, located inside the water hose storage compartment, to its right hand position and pull the water hose out far enough to connect with the city water source. Or you can connect a 5/8" high pressure hose to the water inlet fitting located under the rear roadside corner of the trailer, just forward of the bumper. Turn the hose on and slowly open an inside faucet until the water flows free of air. The system will now be ready for use. If you are staying for some time where city water is available, drain the water storage tank. The drain valve is accessible through a hole in the floor below the galley sink. Be sure to refill the tank with fresh water before departing. The system has check valves in the

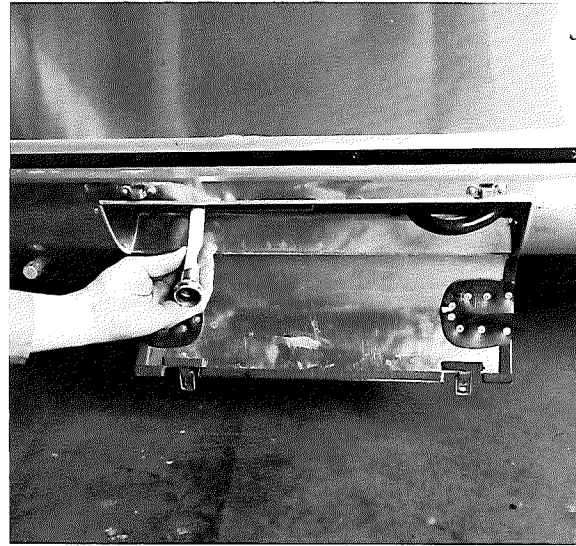

*Water Supply Inlet and Water Hose Storage*



*Water Tank Fill Spout*

water lines to protect the water tank while you are connected to the city water supply.

The water tank is located under the floor just forward of the axle. To fill the water storage tank, open the filler spout (see photo) on the exterior wall adjacent to the galley, and fill with a hose or a bucket, until the water supply pipe is overflowing. Close and lock the spout and the water system is ready to use.

To clean the tank, pour some bicarbonate of soda into the filler spout with several gallons of water and allow to stand for a minimum of four hours. Then flush the tank out by opening the drain valve and running fresh water through it.

If the water tank must be cleaned further, the following procedure is recommended.

1. Prepare a sodium hypochlorite solution using potable water and household bleach

- (5¼ or 6%) in the ratio of 1/4 cup of bleach to 1 gallon of water. (Common household bleaches are Purex and Clorox.)
2. Pour 1 gallon of hypochlorite solution for each 15 gallons of capacity into the empty water tank.
3. Add enough potable water to completely fill the water system.
4. Allow closed system to stand for three hours.
5. Drain the hypochlorite solution from the system and refill with potable water.
6. Excessive hypochlorite taste or odor remaining in the water system is removed by rinsing the system with a vinegar solution mixed in the ratio of 1 quart of vinegar to 5 gallons of water.
7. Drain the system and flush with potable water.
8. Drain the system and refill with potable water.

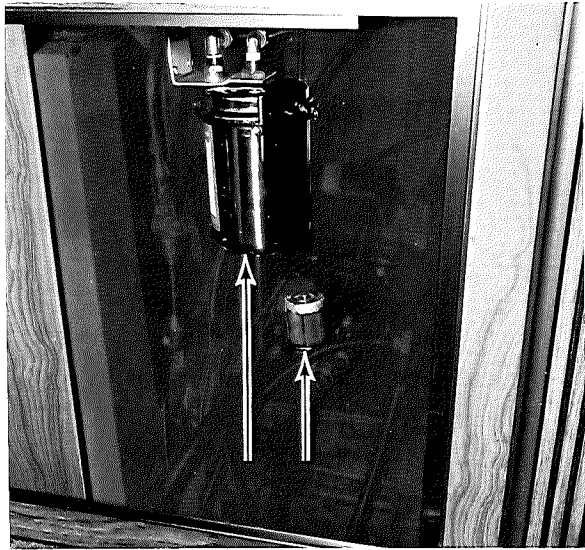

*Water Pump Filter and Water Purifier*

The water pump and filter are under the Galley Sink. The filter screen should be cleaned periodically to prevent accumulation of dirt and sand. To remove the screen, disconnect the rubber hoses from both ends, separate the screen housing, remove the screen, clean and replace.

The Everpure EN-1 Water Purifier is located under the galley sink. It will remove all dirt and colloidal matter, and eliminate most chlorine, phenol and similar odors and tastes while delivering sparkling taste-free water for drinking and cooking. The filter is connected to the cold water line only. The purifier is not guaranteed to remove the tastes and odors of iron and sulphur. To remove these tastes, chlorinate the water supply. Super chlorination will precipitate dissolved iron, and the purifier will then remove the formed chlorine salts. To purify any questionable water add 1 tsp. of chlorine (ordinary household bleach)

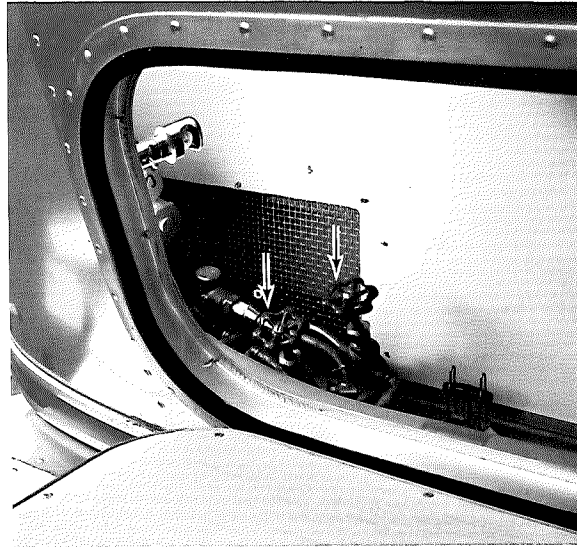

*Water Drain Valve (Rear Bath)*

per 10 gallons of water to the water tank. 4½ tsp. for a 45 gallon tank. We recommend the use of tablets available at Wally Byam Stores. The quality of the water never varies even at the end of the filter pack life, however as the minute pores slowly fill up with impurities, this will gradually reduce the rate of flow until it is necessary to change the filter.

The Water Pressure Regulator is on the roadside of the rear trunk in rear bath models, below the bed in center bath models. It protects the plumbing inside your trailer, regardless of the variation in city water pressures. The pressure at the faucet is kept constant.

The water system has built in drain valves to protect it from winter freezing. For complete details see Storage and Winterizing, page 25.

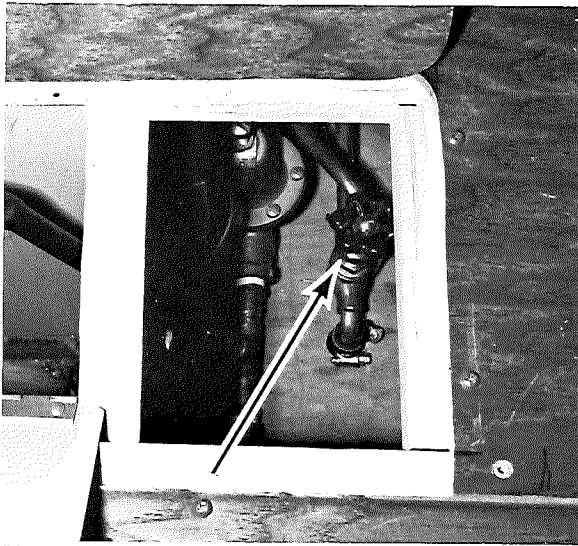

*Water Drain Valve (Center Bath)*

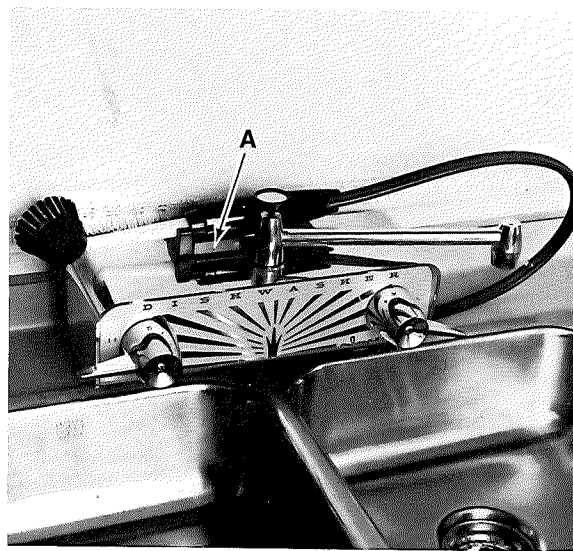

*Manville Dishmaster*

Your Manville Dishmaster is designed to use detergents only. Do not use soaps or soap powders. Always use a liquid detergent and use only one tablespoonful to a tank of water.

Your Dishmaster has a double hose which carries hot water and detergent to an all nylon brush with a push button control providing clean hot suds and clean hot rinse for every dish.

1. Remove the Tank Lid (A) and pour one tablespoonful of LIQUID DETERGENT into the Detergent Tank, then finish filling the Detergent Tank with warm water.
2. Turn on the hot and cold water valves to get the water flow and temperature desired from the spout.
3. Pick up the Dishwashing Handle and pull up on the Black Knob on the Spout to direct the Water through the Brush.

4. Direct the water spray onto your dishes and press the Red Button for suds; release the Red Button for clear hot rinse.
5. When finished washing dishes, turn off your faucet valves and replace the Dishwashing Handle into its holder in back of the spout. The Holder is spring loaded to hold the Brush Handle in place. The Taper Tube will snap in or out of the Holder with little effort. See photograph for correct position of Spray Handle and Brush. Note that the Black Knob on top of the Spout automatically drops down when the water is shut off, thus returning your DISHWASHER to a regular water faucet.
6. When traveling, be sure the detergent tank is empty.

# Drain/Waste/ Vent Systems

Your Airstream has a drain and waste system similar to the one in your home. The system includes waste holding tanks made from molded plastic, free from corrosion problems, with trouble free dump valves. The main holding tank enables you to use the toilet for several days away from disposal facilities. Waste water from the sink, shower, bath and lavatory drain into the auxiliary holding tank. Each tank has its own dump valve, however both tanks drain through a common outlet. Therefore you need to make only one connection when hooking up in a trailer park with sewer facilities.

When the toilet will no longer drain, the main holding tank is full and must be emptied. Watch this closely, because when the tank is full, sewage cannot be emptied from the toilet bowl. In models with a central control panel, check the main holding tank gauge. The auxiliary holding tank must be emptied when the gauge on the central control panel indicates full.

To empty one or both tanks attach the sewer hose by pressing the bayonet fitting onto the dump valve outlet and rotate clockwise until it feels solid and secure. Attach the outlet end of the hose to the sewage outlet, making sure that the hose is placed so that it will drain completely. The dump valves have two wire loops that lock the handle in the closed

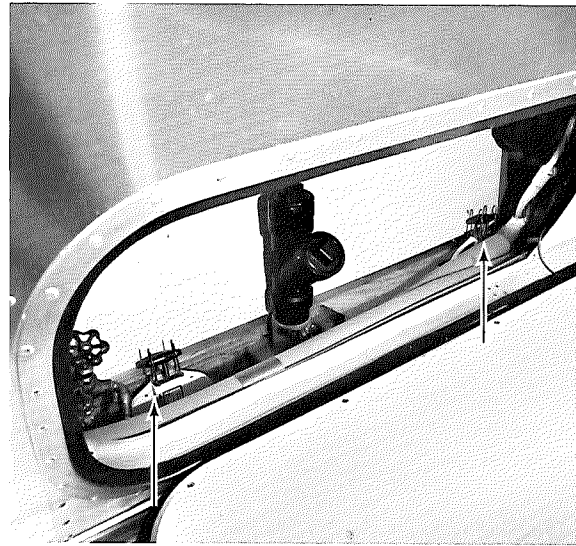

*Rear Bath Dump Valves*

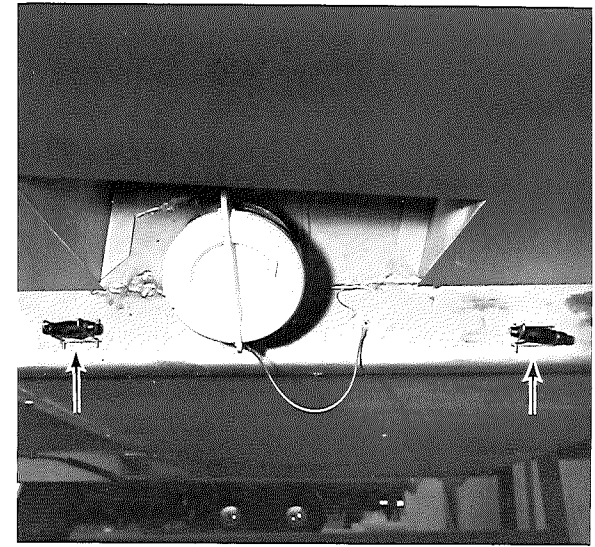

*Center Bath Dump Valves*



*Rear Bath Sewage Outlet*

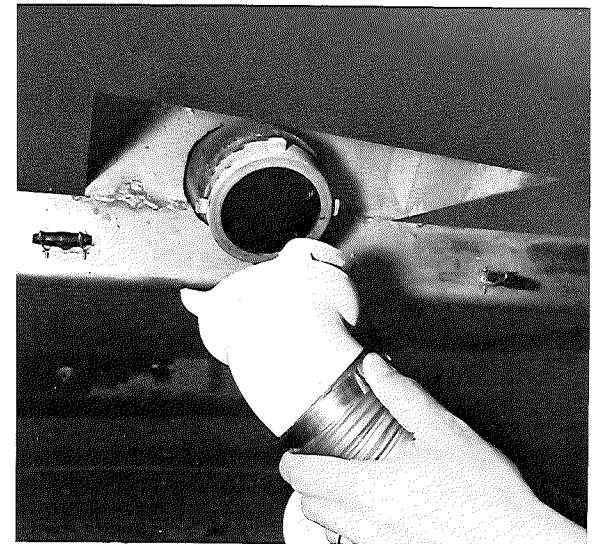

*Center Bath Sewage Outlet*



*Toilet Hand Spray*



*Toilet Pedal Operation*

position. To unlock push outward on the wire loops and they will snap loose, permitting you to open the valve. Pull up the dump valve handle as far as it will go and wait until the tank is drained.

On rear bath models the dump valves are located in the rear trunk compartment. The main holding tank dump valve is located on the roadside and the auxiliary holding tank dump valve is located on the curbside (see photo). On center bath models the dump valves are located on the roadside, just behind the rear wheels, on the main frame rail. The main holding tank dump valve is located to the rear of the sewage outlet and the auxiliary holding tank dump valve is located forward of the sewage outlet (see photo).

The main holding tank must be flushed out until all paper and waste material is removed. Close the dump valve and refill the tank with 10 gallons of clean water and repeat until clean.

On rear bath models, a fitting convenient for flushing the holding tank is in the center of the rear trunk compartment. Replace the plug after using the fitting. The sewer hose is stored in the rear bumper compartment. Rinse out the sewer line before storing.

When connected to a sewer outlet keep the main holding tank dump valve closed and empty the tank every few days or whenever it becomes almost full. Only by sending a large volume of liquid through the main holding tank at a time will toilet paper and other solids completely wash away. This practice

will avoid the accumulation of solids in the main holding tank which could lead to an unpleasant cleaning job. Should solids accumulate and close the dump valve, fill the tank about half full with water, then tow the trailer for a few miles. The turbulence and surging of the water will usually dissolve the solids into suspension so the tank can be drained. Keep the tank valve of the auxiliary holding tank open when connected to a sewer outlet.

**The Aqua Magic toilet** employs a sliding self-cleaning positive seal blade. Odors cannot escape from the holding tank into the trailer. The unit uses less than 2 quarts of water for automatic flush. A special feature is the second pedal attached to the main foot pedal which, when pressed by itself, allows fresh water through either the fill rim or hand spray without opening the slide valve.

When conserving water, use the hand spray in the following way:

1. Hold the hand spray in ready position over bowl.
2. Depress thumb button and step on the foot pedal, which sprays water and dumps the contents at the same time.
3. Spray bowl clean.
4. Release foot pedal, shutting off water flow.
5. If you wish to refill bowl with water for next use, depress small foot pedal till water reaches desired level.

When using automatic flush:

1. Step on main foot pedal, and this will automatically open the slide valve and drop the waste into holding tank.



2. Hold pedal down until water begins to swirl. This fills rim storage and rinses the bowl.
3. Release the foot pedal. This will close the valve blade and stop fresh water from flowing. The bowl will refill automatically.

If you are certain to empty your holding tank every few days, you can use the toilet on automatic flush. It uses very little water and the tank will provide for the requirements of two adults from 2 to 4 days.

Whenever water is scarce, the hand spray flush makes it possible to stay a week or longer in areas where you cannot empty the holding tank. In flushing for urine only, first, wet the bowl with fresh water, and again after use. Starting with a dry bowl takes more water for the final rinse. To flush for urine and solid matter: spray just enough water in the dry bowl to provide for floating the paper and solids. After use, rinse down the sides with the hand spray and empty the bowl. Hold the slide valve open and spray and rinse the lower surfaces. Even if it appears clean, quickly spray it one more time, then release the pedal and it is ready for the next use.

There are certain items that should never be put into the toilet or tank. Facial and other similar tissues: because they have wet strength and do not dissolve easily. Toilet paper, especially white, dissolves well after a period of traveling.

Use only trailer sewage tank deodorizers. Antifreeze, Ammonias, Alcohols and Acetones may cause damage to the tank, valve

parts, tank fittings, and drain hose. For protection against freezing, use recommended fluids (See Winterizing, page 25).

Some state and federal parks prohibit draining sink and bath waters into the ground, although this is done in the wilderness. Your auxiliary holding tank will hold this water until you are at a dump area.

# Electrical System

The exclusive Airstream Univolt System enables you to use the lights and appliances whether operating on self-contained battery power or hooked up to 120 volt city power. This combination unit is designed for protection from damage up to and including a dead short. The 12 volt light bulbs give off the same light as regular household bulbs, so that when operating on self-contained battery power, everything works normally except the 120 volt convenience outlets and electrical operation of the refrigerator.

Convenience Outlets for 120 volts and 12 volts are located throughout the interior of the trailer, see diagrams page 62.

Exterior outlets for 120 V are located on the curbside exterior wall, aft of the main door.

Each 120 volt circuit is protected with circuit breakers to prevent damage due to electrical shorts or overload.

A 30 amp main breaker is provided for additional protection, which will trip should you overload the overall 120 volt system.

Example: If you are operating the air conditioner, Micro Wave oven and vacuum cleaner at one time, the trailer's main breaker would trip. The operation of two of these appliances alone in any combination would not trip the breaker.

When operating with city power, make very certain that the service is 120 volt and not

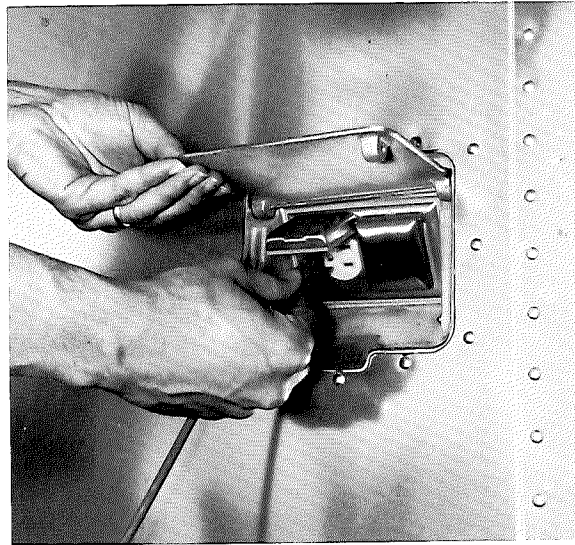

120 Volt Exterior Outlet

220 volt. Roll out the power cord from the automatic reel to the desired length and plug it into the city power source.

The univolt system has a new transformer designed to maintain constant output voltages regardless of the variances that occur in city power systems. The transformer design eliminates the need for complex electronic sensing systems to charge the battery, minimizing the possibility of failures and greatly increasing its overall reliability.

**When the three pronged plug can be used, there will be no problem with proper polarity or grounding. In some older parks and other locations where three pronged outlets are not available, certain precautions to insure proper grounding and polarity must be taken:**

1. Attach the three pronged plug to a two prong adapter. The third conductor line of

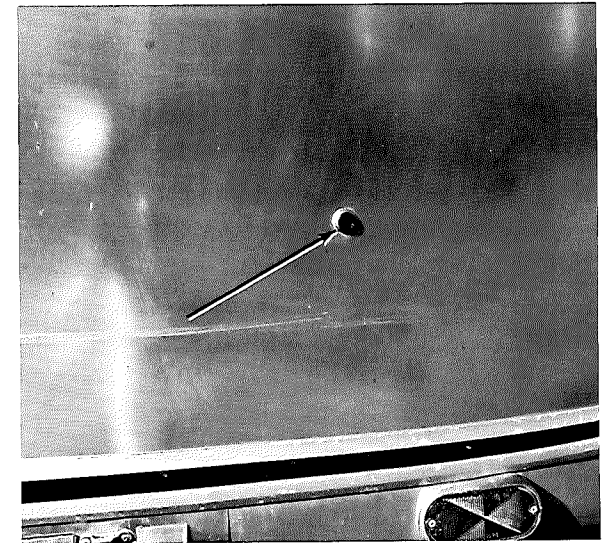

Polarity Warning Light

this adapter has a short wire lead which must be grounded.

2. For proper grounding connect the ground lead to a grounded outlet box or to a cold water pipe. When no water pipe is available, experienced trailering people will drive a metal rod two feet into the ground and attach the ground lug to it thus providing the unit with proper grounding.
3. Check the polarity light located above the water heater access panel.

The polarity warning light indicates improper polarity and it should be off when the power supply cable is used with a two pronged adapter. It may occasionally glow when the three wire system is in use, but your trailer is properly grounded, and in this case you may ignore the light.

To operate self-contained, simply disconnect the power supply cable from the city power

receptacle. Store the supply cable in the hose storage compartment.

When your Airstream is hooked up to 120 volt A.C. the Univolt System automatically charges the trailer battery and, if it is hooked up, your automobile battery as well. The speed and degree of charge depends on how much power is used for lights and appliances, as only the surplus goes to charging the battery. (Please refer to the specifications section for more information on power consumption.) If you are making an extended stay or storing your Airstream, then you should (if it is available) keep your trailer hooked up to 120 volt current.

Whenever possible, use the automatic built-in charger of the Univolt System for charging. The charging circuit automatically controls the current, reducing it as the battery increases in charge. At service stations, make certain they give your battery a slow charge because quick charges will drastically shorten the life of the battery as will allowing repeated complete discharges.

The Univolt is located at the rear curbside interior next to the bathtub in rear bath models, and is accessible through the rear wardrobe.

On center bath models the Univolt is located under the galley and is accessible through a door below the range.

On rear bath models the 120 volt circuit breaker panel is accessible in the rear bathroom cabinet.

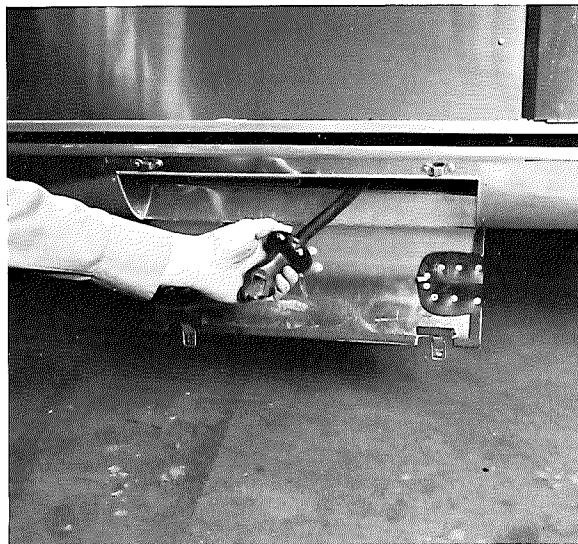

120 Volt Inlet

On center bath double bed models it is located in the rear night stand.

In the event of failure of a 120 volt circuit, check your circuit breaker first. While you are connected to the 120 volt receptacle, the wiring is protected by circuit breakers in the breaker panel providing the polarity and grounding is correct. If a breaker continues to trip after you have reset it several times, your circuit may be overloaded with appliances or there may be a short in the circuit. If lessening the load does not solve the problem consult an Airstream Service Center or the factory.

The Univolt System and the Central Control Panel are provided with a series of fuses (see illustrations page 65) for the safety of you and your unit. Trouble with the electrical system is extremely unlikely, but if it should occur we recommend that you contact your



Univolt

nearest Certified Service Center for repairs. We have included a trouble shooting chart to be used in emergencies only. Details of electric motor amperage, light bulb size, and fuse and circuit breaker locations are shown on the chart in the specifications section on pages 66-67 .

When being towed, the 12 volt battery in your Airstream is receiving a constant charge from the car's generator or alternator through the Seven Way Connector. The charge rate is controlled by your automobile's voltage regulator. It is important to keep the seven way connector clean: one method is to use "Spra-Kleen."



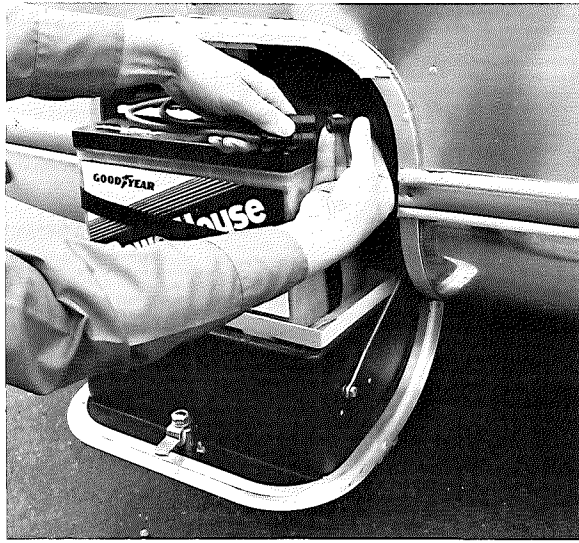

*Battery Cable Quick Disconnects*

## Battery

A normal battery will discharge by itself in 30 to 45 days, therefore, it is necessary to periodically check the battery and charge it as is necessary. We suggest checking the battery at least every two weeks in freezing weather. A fully charged battery will not freeze under any normal circumstances, therefore, it is imperative that you keep your battery charged during the winter. A safe level of charge is a specific gravity reading of 1.225. A fully charged battery has a specific gravity of 1.250 to 1.280. Always use a hydrometer which has a temperature correction scale.

Maintain a clean battery top and check terminals and cables for tightness and cleanliness. A dirty battery will dissipate its charge through surface contamination. Clean battery top with a damp cloth and dry thoroughly.

The terminals should be tight and free of corrosion. To clean terminals, neutralize with a solution of baking soda, rinse in clear water, and dry. Prior to reinstalling, coat terminals and battery posts with a light film of non-metallic grease. Petroleum jelly will do as an alternate, but will require more frequent application. **Important: reconnect the battery cables to the correct battery posts.** For example, if negative ground the black cable should be connected to the negative ( - ) post and the red cable to the ( + ) post. The polarity may be determined by inspecting the battery post which is grounded on the tow vehicle, since it must always match the trailer. For example, if negative pole of the tow vehicle is grounded, the polarity of the trailer battery is negative ground.

Add water to cells as necessary. Check the electrolyte level at least once a month. When you are traveling steadily and for an extended period of time, or you are in climates above 90°F check the electrolyte level every two weeks.

**Caution:** The gases generated within a storage battery cell may be ignited by an open flame or spark in the vicinity of the battery. **Do not use a match to provide light for checking the level of water.**

During the winter the battery should be removed from the Airstream and stored in a cool, dry place, kept full of water, cleaned and charged monthly. A battery which is allowed to completely lose its charge will never regain its original power, or a full charge.

On rear bath models the battery is located in a rear curbside compartment. On center bath models it is located in a front curbside compartment. The battery slides out onto the opened door for service and removal. For removal it is not necessary to remove cables from battery terminals, just pull quick disconnects apart (see photo).

For battery service or replacement, go to any service station or dealer who sells and services this battery. The battery is rated for 105 amp. hours at 80°F and has a 5 year prorated warranty.

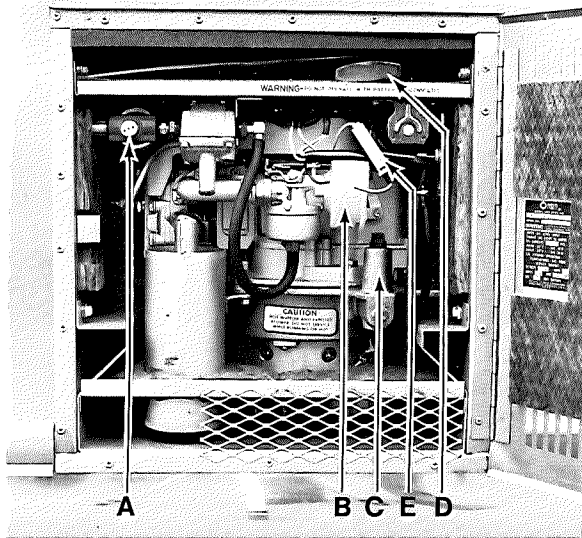

Battery Charger Controls and 3 Amp Fuse

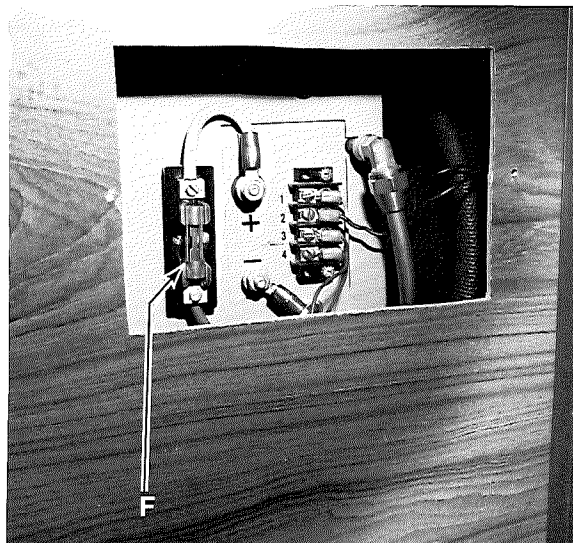

50 Amp Fuse (Interior Access)

## Battery Charger

To identify your particular model, refer to the model and specification letter given on the nameplate. Electrical characteristics of the unit are also given on the nameplate.

How to interpret MODEL and SPEC letter:

0.3	TL	212R	/	1	B
1	2	3		4	5

1. Indicates watt rating (0.3 = 300 watts).
2. Factory code for series identification.
3. Indicates voltage code: 212 indicates 12 to 15 volts DC, R indicates remote electric starting.
4. Factory code for optional equipment. Number 1 indicates basic unit.
5. Specification letter which advances when factory makes production modifications.

If necessary to contact a dealer or the factory regarding the unit, always mention the complete model, specification letter and serial number as shown on the Onan nameplate. Refer to the engine nameplate if requesting information from its manufacturer.

The Onan TL Battery Charger is a complete unit made up of a DC generator driven by a single-cylinder, 4-cycle Tecumseh engine. Gaseous-fueled (LPG), the unit can be electric started by the remote control or manually by the use of the recoil starter. The generator is mounted directly on the engine and is positioned in the lower portion of the battery charger compartment. Remote control for the unit, located on the curbside wall in the living room, contains the adjustable timer, start button and charge indicator lamp.

### Specifications:

Engine	Tecumseh - 1 cylinder
Fuel	Propane gas
Normal Fuel Consumption (at rated load)	0.9 lb/hr
Generator (combination starter & DC generator)**	
Rated Voltage (2000 rpm)	15
Amperes (2000 rpm)	20
Ground	Negative only
Remote Control	
Timer Operation Settings (hours)	0 to 3
Remote Start	Yes

\*\*Rated output to 8000 feet altitude.

### Operation:

Before initial starting of the TL Battery Charger, check all the fuel connections, oil level, battery water level, wire connections and fuses. Fuses that are to be checked are located on the battery charger and the Univolt. A 3 amp fuse (E) and 50 amp fuse (F) are located on the battery charger (see photos). Three are located on the Univolt; a 40 amp fuse Car Battery + (pos.), a 50 amp fuse Trailer Battery + (pos.) and a 50 amp fuse Trailer Battery - (neg.). See schematic on page 65. Check the air inlet and outlets for obstructions which could cause overheating. Be sure the crankcase has been filled with oil. Oil level is 1/8 inch below top of fill opening when the unit is level. Pour oil slowly to prevent trapping air. See Maintenance and Service Section for all types and complete lubricating oil recommendations.

Do not operate with the battery disconnected or if any fuse is blown at the Univolt as some components such as light bulbs can be damaged. If the battery charger is operated under these conditions, the 3 amp fuse (E) will blow, preventing the generator from charging. Although the motor will continue to run, the generator will not charge the battery. Periodically check 3 amp fuse to make sure generator is charging properly.

If the engine doesn't start initially after using the following instructions, remove the spark plug, clean, dry thoroughly and re-install. Smoky exhaust, due to oil in the cylinder, might appear on initial start and is normal.

#### Electric Starting

1. Turn the adjustable timer on the remote control to the desired duration of operation.
2. Push the START BUTTON on the remote control to crank the engine.

If the timer is set to zero, the unit won't start regardless how long cranking is continued.

Note: For easier starting in cooler temperatures, the choke can be manually closed while the engine cranks — helps draw fuel through the fuel regulator. The choke is located on engine carburetor.

#### Manual Starting

1. Turn the adjustable timer on the remote control to the desired duration of operation.
2. Push in the fuel solenoid button (A).
3. Pull the start rope (D) with a fast, steady pull to crank the engine.

4. As soon as the engine is running, release the fuel solenoid button. Generator current now holds the fuel solenoid open.

#### Battery Charging

The charge rate of the TL battery charger is factory set for battery charging. A small lamp marked "GENERATING" lights once the unit is running and charging properly. Operation time ranges to 3 hours and is set by the adjustable timer on the remote control.

Light loads, appliances or fixtures, can be operated from the battery while the unit is running. If the load should ever exceed generator capacity, the generator field will collapse and prevent any damage. As an indication the small "GENERATING" lamp on the remote control will fail to light when the generator field collapses. Remove some load for proper operation.

As a general guide, a 105 ampere-hour battery requires approximately 3 hours charging if the battery is in a low charge condition. For a more exact determination, use a hydrometer.

#### Stopping

Stopping occurs automatically when the adjustable timer on the remote control returns to zero. If you wish to shut down the unit before automatic shutdown, manually turn the pointer on the timer back to zero.

#### High Temperatures

1. See that nothing obstructs air flow to and from the unit.
2. Keep cooling fins clean.

### Critical Maintenance Schedule

Maintenance Items	Operational Hours	
	200	500
Inspect Magneto Breaker Points	x	
Clean Commutator	x1	
Check Brushes	x2	
Clean Generator	x	
Grind Valves		x

x1 Perform more often in extremely dusty conditions.

x2 Replace brushes when worn 7/16 inch or less.

### Owner Maintenance Schedule

Maintenance Items	Daily	Operational Hours			
		4	25	50	100
Inspect Unit	x				
Check Fuel	x				
Check Oil Level		x			
Clean Air Cleaner			x1		
Change Crankcase Oil			x1		
Clean Governor Linkage				x1	
Check Spark Plug					x
Clean Crankcase Breather					x

x1 Perform more often in extremely dusty conditions.

### Low Temperatures

1. Use correct SAE oil for temperature conditions. Change oil only when engine is warm.
2. Keep batteries in a well charged condition.
3. Partially restrict cool air flow if necessary, but use care to avoid overheating.

### Extremely Dusty or Dirty Conditions

1. Keep unit clean. Keep cooling system clean.
2. Service air cleaner as frequently as required.
3. Change crankcase oil more often than shown in Maintenance and Service.
4. Keep governor linkage clean.

### Out-of-Service Protection

Protect an engine to be out-of-service for more than 30 days as follows:

1. Run unit until thoroughly warm.
2. Turn off fuel supply.
3. Drain oil from oil base while still warm. Refill and attach a warning tag stating oil viscosity used.
4. Service air cleaner and cover with plastic.
5. Wipe entire unit. Coat rustable parts with a light film of grease or oil.
6. Cover air inlet and outlet openings.
7. Disconnect battery and follow standard storage procedures.

### Service and Maintenance:

Regularly scheduled maintenance is the key to lower operating costs and longer service life for the unit. However, actual operating conditions under which a unit is run should be the determining factor in establishing a maintenance schedule. When operating in very dusty or dirty conditions, some of the service periods may have to be reduced. The schedules are divided into two categories: **Owner Maintenance Schedule** — performed by the owner, and **Critical Maintenance Schedule** — performed by qualified service personnel.

For any abnormalities in operation, unusual noises from engine or generator, loss of power, overheating, etc., contact your dealer or factory.

### Crankcase Oil

Check the oil level every 4 hours of operating or before each time the unit is used. Change oil every 25 hours but more often if operated in extremely dusty or dirty conditions. For

the first fill of oil on a new unit, change oil after two hours operation.

The oil capacity of the engine is 21 ounces. Fill to the oil level which is 1/8 inch below the top of the oil fill opening (C). Pour slowly to prevent trapping air.

When adding oil between changes, always use the same brand that is in the crankcase. Various brands of oil may not be compatible when mixed. Ambient temperatures must be the guide for selection of the proper weight oil. Following are recommendations:

Above 32 F — use SAE 30

Below 32 F — use SAE 10W

Use a good quality, heavy duty oil with the API (American Petroleum Institute) designation SE or SE/CC. Don't use an oil with the designation CD unless it is also designated SE and the oil manufacturer certifies it will perform satisfactorily in gasoline engines.

Note: If oils with these designations are not yet available, use an oil with the API designation MS, MS/DG or MS/DM which has passed all the Automotive Manufacturer's Sequence Tests and the MIL-L-2104B Tests.

#### **Air Cleaner**

The polyurethane type air cleaner (B) must normally be cleaned every 25 hours, more often if the engine runs rich and emits black, smoky exhaust due to clogged air cleaner element. To service the air cleaner, remove the air cleaner cover. Then remove the polyurethane element and wash in a detergent and

water solution as you would a sponge. Squeeze out the cleaning solution and re-oil the element by applying generous amounts of oil to the sides and open ends. Squeeze to distribute the oil and remove excess oil. Reinstall the element and air cleaner cover.

#### **Crankcase Breather**

To remove the crankcase breather assembly (located behind cylinder intake pipe), take out the fastening screws and lift off the breather assembly. The breather has the filtering element held in the cover by a small barb. Depress the element with a blade between the element and cover. Once the element is loosened from the barb, the element can be removed from the cover.

Clean the element with a suitable solvent or household detergent. Blow out the solvent or cleanser used with low pressure air. When re-installing the breather assembly, the drain hole or rectangular opening is at the bottom. Note: The filtering element doesn't have to be lubricated before re-installing because it's lubricated by crankcase vapors during operation.

#### **Ignition**

Every 100 hours, remove, inspect, clean and regap the spark plug to .020". If the plug looks discolored or has fouled, replace it. Because the plug used is a special length plug for installation, use the same plug type as the original or equivalent.

# Electrical Outlet Locations

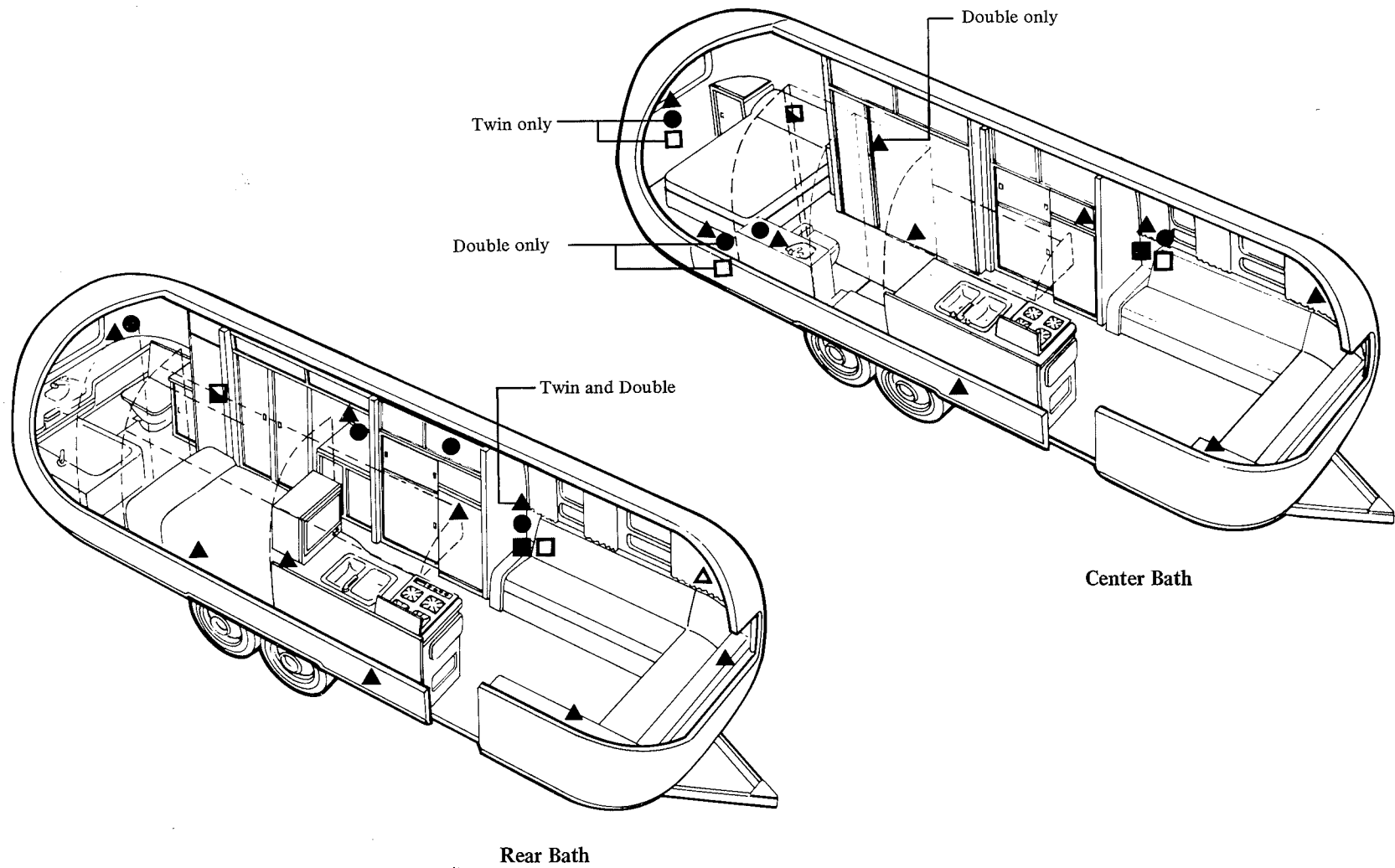

- ▲ 120V (standard)      ▲ 120V (optional)      ■ Telephone Jack      □ T.V. Jack
- 12V (standard)      ▽ Telephone Inlet

# Electrical Trouble Shooting

Symptom	Possible Cause	Remedy
No 12-volt power (Lights, appliances do not work)	<ol style="list-style-type: none"> <li>1. Input line and/or battery not connected</li> <li>2. Trailer battery on wrong polarity</li> </ol>	<ol style="list-style-type: none"> <li>1. Make necessary connections</li> <li>2. See items 3, 4, 5, and 6</li> </ol>
Blown fuse	<ol style="list-style-type: none"> <li>3. Overloaded circuit (over 50 amps)</li> <li>4. Electrical short</li> <li>5. Shorted battery</li> <li>6. Battery terminals not properly corrected to UNIVOLT + and - terminals</li> </ol>	<ol style="list-style-type: none"> <li>3. Turn off switches to reduce load. Replace blown fuse in Univolt or next to Univolt.</li> <li>4. Find blown fuse in Univolt and identify circuit. From wiring diagrams check the circuit for defective wiring, lamps or motors.</li> <li>5. Replace battery and fuse</li> <li>6. Make proper connections; replace fuse</li> </ol>
Dim lights or sluggish fan motor	<ol style="list-style-type: none"> <li>7. 25- or 50-cycle power (some foreign countries)</li> <li>8. Discharged battery (when operating without 120-volt line)</li> <li>9. Battery is low on water</li> </ol>	<ol style="list-style-type: none"> <li>7. Use 60-cycle power</li> <li>8. Charge battery</li> <li>9. Add distilled water to battery</li> </ol>
UNIVOLT will not charge battery	<ol style="list-style-type: none"> <li>10. Input line not connected</li> <li>11. Battery not connected (or polarity reversed)</li> <li>12. Bad battery</li> <li>13. Too many lights and appliances in use</li> <li>14. Fuse blown</li> </ol>	<ol style="list-style-type: none"> <li>10. Connect input line</li> <li>11. Connect battery to UNIVOLT</li> <li>12. Replace battery</li> <li>13. Reduce electrical load</li> <li>14. Replace fuse</li> </ol>



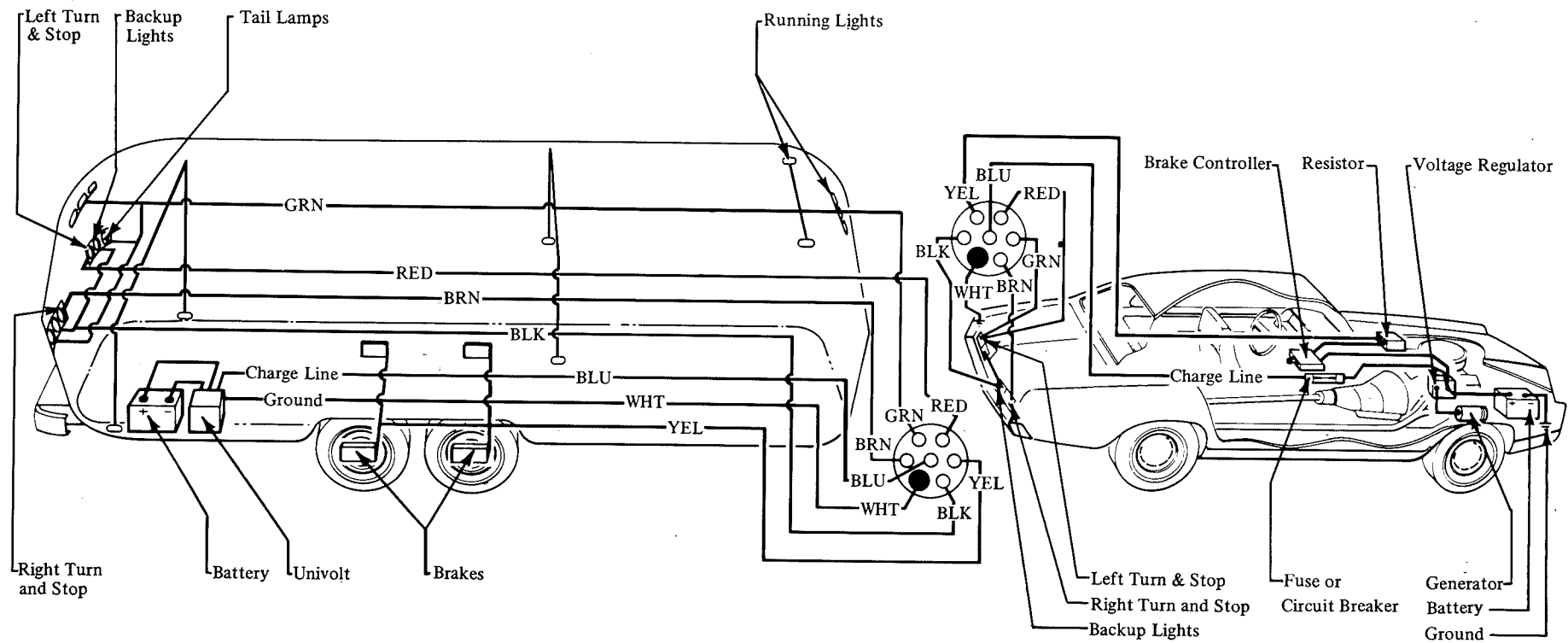

### Car-Trailer Electrical Connector

Polarity of trailer battery must match polarity of car battery. e.g. If negative pole of car battery is grounded, negative pole of trailer battery must be grounded.

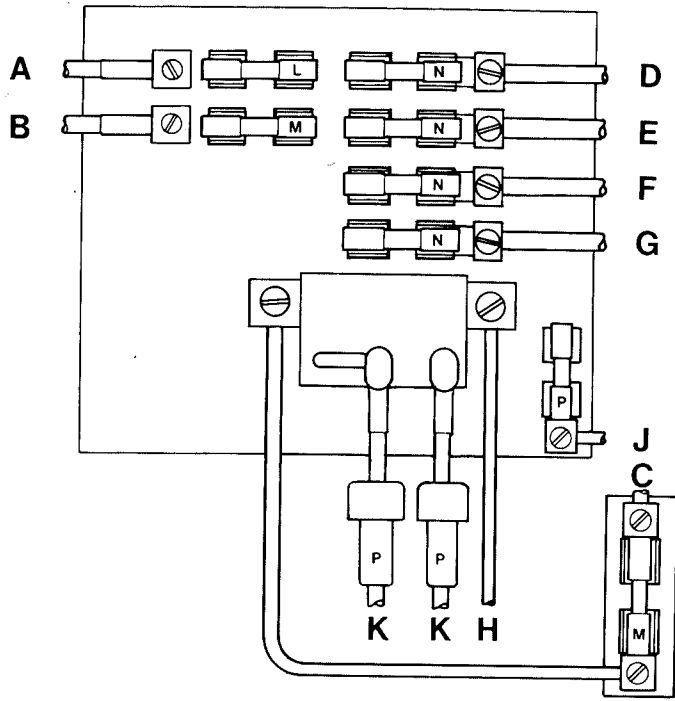

Low Voltage Distribution Panel

- A — Car Battery (pos) & Circuit #5
- B — Trailer Battery + (pos)
- C — Trailer Battery - (neg)
- D — Circuit #1
- E — Circuit #2
- F — Circuit #3
- G — Circuit #4
- H — Negative Load
- J — Power-On-Light
- K — Ammeter
- L — AGU 40 - amp - Fuse
- M — AGU 50 - amp - Fuse
- N — SFE 20 - amp - Fuse
- P — SFE 4 - amp - Fuse

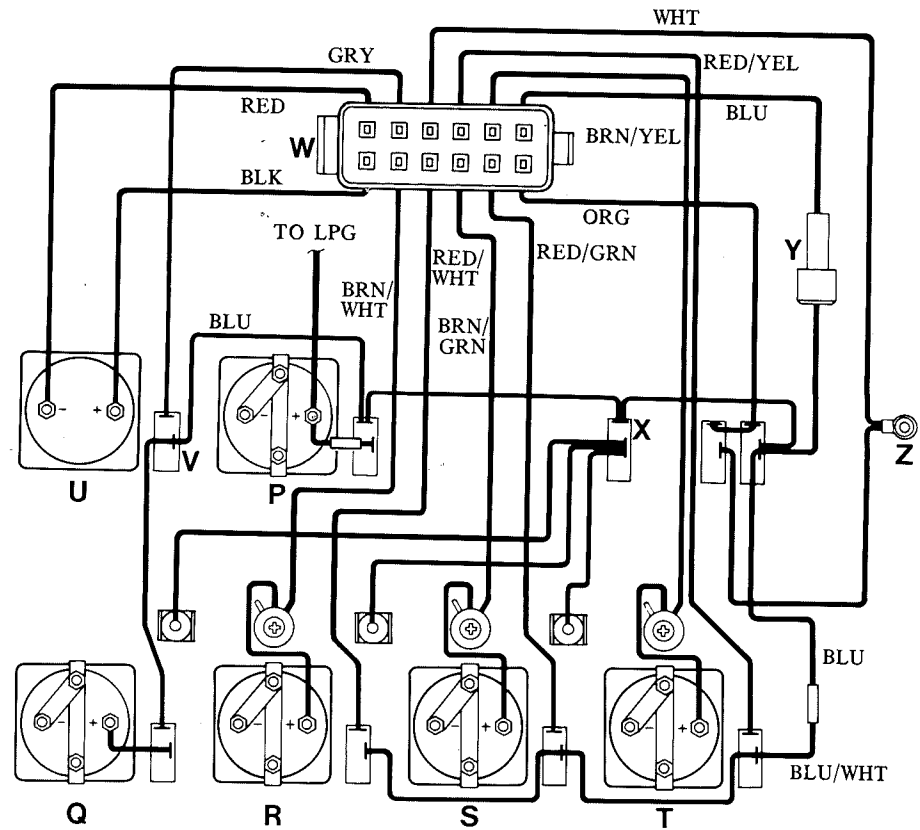

Central Control Panel

- P — LPG Tank
- Q — Battery
- R — Water Tank
- S — Auxiliary Holding Tank
- T — Main Holding Tank
- U — Ammeter
- V — Power On Light
- W — Connector
- X — Panel Light
- Y — Fuse
- Z — Ground to Panel

# Specifications

## Capacities

Appliance	Capacity
Main Holding Tank (Rear Bath)	20 gal.
Main Holding Tank (Center Bath)	17 gal.
Auxiliary Holding Tank (Rear Bath)	10 gal.
Auxiliary Holding Tank (Center Bath)	17 gal.
Water Tank	45 gal.
Water Heater	10 gal.

## Light and Appliance Amperages

Item	Lamp Number	Amperage
Control Panel Light	53X	.1
Water Pump	—	9.9 max.
Ceiling Fan	—	4.8
Bathroom Exhaust Fan	—	2.0
Range Exhaust Fan	—	2.0
Furnace Fan	—	5.0
Toilet Exhaust Fan	—	2.0
Reading Lights:		
Living Room	1383	1.6 each bulb
Bedroom	1141	1.6 each bulb
Main Door Light	1141	1.6
Exterior Light	1156	
Ceiling Light (6 Bulbs):		
Living Room, Galley	1141F	1.6 each bulb
Bedroom, Bathroom	1141F	1.6 each bulb
Galley and Vanity Lights under Roof Locker	1141	1.6 each bulb
Trunk Lights:		
Service Center, Trunk	67	.6 each bulb
Clearance & Cluster Lights	1895	
Stop & Turn Signal	1156	
Tail Light	1157	
License Plate Light	89	
Backup Lights	1156	
Battery		105 amp hrs.
Fluorescent Lights,	F15T8WW	

## Fuses and Circuit Breakers

Circuit	Location	Rating
Main Breaker	120 volt panel	30 amp
General Circuit	120 volt panel	15 amp
Appliance Circuit	120 volt panel	20 amp
Air Conditioner	120 volt panel	20 amp
Charge Line from Car	Univolt	AGU 40 amp fuse
Low Voltage Circuits	Univolt	SFE 20 amp fuse
Trailer Battery Fuse (+)	Univolt	AGU 50 amp fuse
Trailer Battery Fuse (-)	Nxt. to Univolt	AGU 50 amp fuse
Power On Circuit	Univolt	SFE 4 amp fuse
Ammeter	Nxt. to Univolt	SFE 4 amp fuse
Central Control Panel	Main Cen. Ctrl. Pnl.	AGC 15 amp fuse
Radio, Radio/Tape	Radio, Radio/Tape	IAG 5 amp fuse
Battery Charger	Battery Charger	AGA 3 amp fuse
Battery Charger	Battery Charger	AGU 50 amp fuse
<i>WATER PUMP</i>		<i>6" x 50-100</i>

# Pre-Travel Check List

---

## Interior

1. Turn off water pump switch.
2. Check battery water level.
3. Close windows and vents.
4. Turn off Gas to Range & Oven.
5. Lock all interior cabinet doors.
6. Lock refrigerator door (Seal containers first.)
7. Hold down or stack securely all loose, hard and sharp objects.
8. Fasten sliding & foldette doors.
9. Drain toilet bowl.
10. Turn off interior lights.
11. Secure and lock the Main door.
12. Pull up step.

## Exterior

1. Disconnect and stow:
  - a) electrical hook-up cord
  - b) sewer-hose hook-up hose. (flush out)
  - c) water hook-up hose.
2. Turn off gas line shut-off valve to appliances.
3. Remove and stow leveling jacks and wheel chocks.
4. Check hitch: it must be properly attached.
5. Check safety chains and breakaway switch cable.
6. Fully retract jack. Remove and stow dolly wheel.
7. Check clearance and stop lights.
8. Check lug bolts.
9. Check tires, for correct pressure see page 15.
10. Check that TV antenna is pointed forward and dipoles closed.
11. Adjust car mirrors.
12. Pull forward some 50 ft., test brakes, and check site for forgotten objects and cleanliness.

## Home

1. Leave key with your neighbor.
2. Store valuables and important papers in a safe place.
3. Discontinue newspaper, milk and other deliveries.
4. Ask the Post Office to hold your mail for you.
5. Arrange with the Telephone Company for discontinued or 'Vacation Service'.
6. Arrange care for your pets.
7. Have your lawn, garden and house plants cared for.
8. Lock all windows and doors securely. Keep shades open for a lived-in look.
9. Cover all food to keep out mice and insects.
10. Eliminate all fire hazards. Place matches in a tin box or glass jar.
11. Store oil, gasoline and other inflammables properly.
12. Destroy all newspapers, magazines and oily rags.
13. Notify police.

## Personal

14. Automobile insurance to cover you and your family fully.
15. Avoid cash. Use travelers checks and credit cards.
16. Confirm reservations.
17. Have sunglasses for everyone.
18. Pack cameras and films.
19. Make a check list of clothing for everyone, and toilet articles.

---

## Motoring Essentials

1. Display car and trailer registration properly.
2. Carry driver's license. In Canada you will need a non-resident liability insurance card.
3. In Mexico you must have special auto insurance.
4. Carry an extra set of ignition and trunk keys in a separate pocket, or in your wallet.
5. Keep an operating flashlight with fresh batteries in the glove compartment.
6. Pack the trunk so that you can reach the tools and spare tire without completely unpacking.
7. Keep sharp or hard articles securely packed wherever they may be.
8. Do not pack things in the passenger sitting area, you need maximum space for comfort.
9. Wear easy-wash, drip-dry traveling clothes.
10. Do not make your vacation trips a mileage marathon! Stop and relax frequently.
11. Carry a first aid kit.
12. Carry your pet's dish, food, leash and health and registration papers.

# Lubrication and Maintenance

Your Airstream is without a doubt the finest engineered travel trailer ever to be mass-produced. Every design feature and component has been chosen with the thought in mind of giving you thousands of miles of trouble-free operation. By adhering to the following

minimum maintenance schedule and the additional exterior and interior maintenance suggestions you will enjoy all of the pleasure you dream of from your trailer . . . and more.

Item	Every 1,000 miles or 30 days	Every 5,000 miles or 90 days	Every 10,000 miles or 6 months	Procedure
All Exterior Door Locks	X			Lubricate by shooting in dry graphite.
Battery	X			Check water level – fill with distilled water only.
Battery Charger				See page 58.
Brakes			X	Inspect and adjust.
Break Away Switch		X		Pull pin and lubricate with light household oil.
Entrance Door Hinges	X			Lubricate with light household oil.
Hitch Ball Latch	X			Lubricate with engine motor oil.
Hitch Jack	X			Lubricate with light household oil (put oil can spout up under handle and allow oil to run down post).
LPG Hold Down Knob	X			Lubricate with light household oil.
Main Door Step	X			Lubricate moving parts.
Range Exhaust Hood				Clean fan blades and wash filter.
Refrigerator Flue Cleaning		X		See page 42.
Roof Vent Elevator Screws	X			Lubricate with light household oil.
Strike Pocket on Main Door	X			Coat with paraffin.
Tires	X			Check for foreign objects. Air pressure – page 15.
Water Pump		X		Check belt for wear and proper tension.
Wheel Bearings			X	Clean, repack, and adjust.
Wheel Lug Bolts		X*		Check for tightness.
Window Seals/Door Seals		X		Clean with mild detergent and coat with "Slipicone."
7-Way Plugs and Receptacle		X		Clean contacts and coat with "SPRA-KLEEN."

\*Note: On new trailers check lug bolts every 200 miles for the first 1,000 miles.

Note: If and when new materials and production techniques are developed which can improve the quality of its product, Airstream reserves the right to make such changes.





# Index

Air Conditioner .....	36	Electric Jack (Hitch) .....	16	Oven .....	44	Tires .....	15
Aluminum Shell .....	28	Equipment List .....	10	Oven Cleaning .....	45	Tire Pressures .....	15
Ammeter .....	33	Extended Stay .....	22	Overheating .....	18	Toilet .....	53
Amperage Chart .....	66	Extension Step .....	29	Overnight Stop .....	21	Towing Tips .....	18
Automatic Gas Regulator .....	40	Exterior .....	28	Panel Switches .....	33	Trailer Storage .....	25
Axle .....	12	Exterior Check List .....	68	Panel Gauges .....	33	Trouble Shooting:	
Backing .....	20	Factory Service .....	4	Pilot Adjustment:		Electrical .....	63
B.A.L. Stabilizers .....	22	Fan Switch .....	36, 37	Furnace .....	46	Furnace .....	47
Ball (Hitch) .....	16	Filter (Air Conditioner) .....	36	Oven .....	45	Range and Oven .....	43
Battery .....	57	Filter (Water) .....	50	Range .....	45	Refrigerator .....	41
Battery Condition Tester .....	33	Flat Tires .....	15	Refrigerator .....	41	Water Systems .....	49
Battery Charger .....	58	Fluorescent Lights .....	38, 66	Water Heater .....	48	TV Antenna .....	29
Brake Controller .....	12	Foldaway Step .....	28	Personal Check List .....	68	TV Jacks .....	62
Brakes .....	12	Gas (LPG) System .....	40	Power On .....	34	Univolt .....	56
Bulbs (Replacement) .....	66	Gas Tank .....	40	Polarity Light .....	55	Utility Connection .....	23
Bunk Beds .....	32	Gauge Recalibration .....	33	Range .....	44	Vacuum Cleaner .....	39
Capacities .....	66	Grounding .....	55, 58	Refrigerator .....	41	Vents .....	37
Car Connector .....	17, 64	Hitch .....	16	Refrigerator Defrosting .....	41	Vista View Windows .....	29
Cargo Capacity .....	15	Hitch Ball Height .....	16	Registration .....	4	Warranty .....	5
Ceiling Fans .....	37	Hitching Up .....	16	Regulator (LPG) .....	40	Water Drainage Procedure .....	25, 50
Ceiling Vents .....	37	Holding Tanks .....	52	Repair Centers .....	6	Water Drain Valves .....	25, 50
Central Control Panel .....	33	Home Check List .....	68	Removing Moisture .....	47	Water Filter .....	50
Chassis .....	12	Interior Check List .....	68	Running Gear .....	11	Water Heater .....	48
Check Lists .....	68	Interior Maintenance .....	32	Self-Contained (Drainage) .....	52	Water Inlet .....	49
Circuit Breakers .....	56	Jacking Trailer .....	21	Self-Contained (Electrical) .....	55	Water Level Gauge .....	33
City Power .....	55	Lubrication Chart .....	70	Service Centers .....	6	Water Pressure Regulator .....	50
Clock .....	34	Lubrication and Maintenance .....	70	Sewer Connection .....	52	Water Pump .....	50
Defrosting .....	42	Leveling .....	22	Shower Head .....	38	Water Purifier (Filter) .....	50
Dishmaster .....	51	Leveling Bars .....	16	Sink Maintenance .....	36	Water System .....	49
Drainage System .....	52	Light Bulb Replacement .....	38, 66	Specifications .....	66	Weight: HP Ratio .....	11
Dump Valves .....	52	Lights .....	37	Stabilizing Jack Positions .....	22	Windows .....	29
Electrical Components .....	55	L.P.G. System .....	40	Switches: Lights .....	38	Winterizing .....	25
Electrical Connector .....	17	Load Chart .....	14	Tank (Sewage) .....	52		
Electrical Inlet .....	56	Loading .....	11	Tank (Water) .....	49		
Electrical Panels .....	33, 65	Micro Wave Oven .....	43	Telephone Jacks .....	63		
Electrical System .....	55	Motoring Check List .....	69	Telephone Shower Head .....	38		