



Exterior

Key - Remote control

Selective unlocking of the cab and load space.
Locking of the load space only.
Complete locking of the vehicle.



2a ▶ 15

Sliding side door

Pull the handle towards you then towards the rear and open the door guiding the rearward sliding until the point of resistance has been passed.



2b ▶ 19



Opening the bonnet

Take care when working under the bonnet.

Raise the bonnet slightly by reaching in a flat hand, palm down, to make access to the lever easier. Engage the base of the strut in the hole provided to hold the bonnet open.

Fix the strut in its location, identified by a sticker on the left-hand panel side of the vehicle.



7a ▶ 113

Professional equipment - Accessories

7b ▶ 110

Key

◻ : chapter identification

▶ : page identification

Hinged rear doors

Asymmetrical (2/3 - 1/3).



This lock makes it possible to keep the large door closed and drive with the small door open.



This control permits opening to approximately 180°.

2c ▶ 20

Rear roof flap

The rear roof flap is only compatible with the hinged doors.



2d ▶ 22

**Spare wheel**

The tools are located under the right-hand seat.

Raise the carrier with the wheel flush against the floor.

In the case of a vehicle fitted with a towbar, the vehicle must be raised in order to disengage the spare wheel from the carrier.



8a ▶ 122

Tailgate and rear screen

2e ▶ 23

Parking assistance

4 ▶ 76

Changing bulbs

8b ▶ 127

Useable dimensions

9 ▶ 138



INSTRUMENTS AND CONTROLS

1. Lights and direction indicators stalk.
2. Instrument panel with display.
3. Wipers, wash-wipe, trip computer controls.
4. Ignition.
5. Audio equipment, hands-free kit control.
6. Driver's air bag, horn.
7. Steering wheel height and depth adjustment.
8. Cruise control, speed limiter switch.
9. Control pad, parking assistance, headlamp beam adjustment, ESP.
10. Bonnet release.
11. Electric exterior mirror adjustment.



CENTRE CONSOLE

1. Gear lever.
2. Controls bar: electric window.
3. Controls bar: hazard warning lights, central locking (passenger compartment, load space).
4. Lighter.
5. Heating-ventilation controls.
6. Storage compartment.
7. Audio equipment, CD changer.
8. Display.

SIT COMFORTABLY

10



Driver's seat



1. Forwards-backwards adjustment.



2. Angle.



3. Height.



4. Head restraint height and angle.

3 ▶ 57



Steering wheel

Adjust the height and depth of the steering wheel.

2 ▶ 37



Storage compartments

These are placed under the front seats. For greater ease, reach behind the seat to access them.

The tool kit and the jack are stored under the right-hand seat and can be accessed from the rear.

3 ▶ 63



Seat belts

Height adjustment.
Fastening.

5 ▶ 97



Mirrors

Manual adjustments.
Electric adjustments.

3 ▶ 73

SEE CLEARLY



Lights stalk



Lights off.



Side lights.



Main beam headlamps

(blue).

Dipped headlamps (green).

AUTO**AUTO**, automatic switching on of the lights.

Motorway function: press up or down once, without passing the point of resistance; the corresponding direction indicators will flash three times.

3 ▶ 40

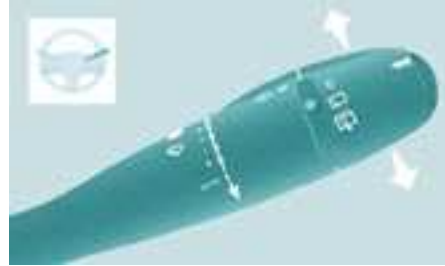

Wipers stalk

2 fast.

1 normal.

I intermittent.

0 off.

↓ single wipe.

AUTO, press the stalk down.

3 ▶ 43

DRIVE SAFELY



Cruise control, Speed limiter

In cruise control mode, the vehicle speed must be higher than 25 mph (40 km/h) with at least 4th gear engaged.

3 ▶ 45, 48



Hill start assistance

3 ▶ 39



Audio equipment, hands-free kit

This can play MP3 CDs and permits the matching of a Bluetooth telephone to the hands-free kit.

4 ▶ 78

CAB SPACE

12



Extenso cab

3 ▶ 59



Side seat

- retracted position, permits the transportation of long loads inside the vehicle, up to 3 m with the doors closed,

3 ▶ 60



Centre seat

A storage space under the seat cushion can be made secure by fitting a padlock (not supplied).

3 ▶ 59



- foldaway position: permits the transportation of high loads in the cab part.

3 ▶ 60

LOAD SPACE



Stowing rings

We recommend that the load is immobilised by securing it firmly using the stowing rings on the floor and that heavy objects are placed at the front (towards the cab).

3 ▶ 68

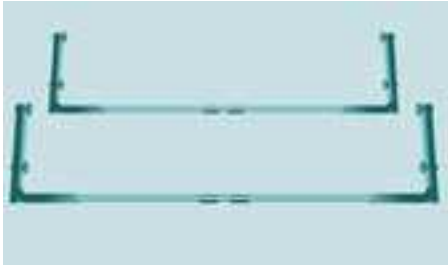

Interior rack

3 ▶ 70



Torch

Incorporated in the wall, this lights the boot and can be removed when changing a wheel, ...

3 ▶ 65



Partitions

5 ▶ 69



Removable flap

This can be removed to permit the loading of long objects.

3 ▶ 69

Maximum loads

Overhead storage compartment: 5kg.
 Retractable seat, in the seat back folded onto seat cushion position: 50 kg.
 Transverse roof bars: 75 kg.
 Interior rack: 10 kg per bar.
 Roof rack: 120 kg.

CHILD SAFETY

14



Air bag disarming

5 ▶ 102



Child seats

5 ▶ 103

VENTILATION



Heating



Air conditioning

3 ▶ 51



Automatic air conditioning

3 ▶ 53

Recommended settings for the Manual Air Conditioning

For optimum use of the system, we recommend:

If I require...	Air distribution	Temperature	Air flow	Air recirculation	AC
Heating					-
Cooling					A/C
De-icing Demisting					3 ▶ 55

With Automatic Air Conditioning, operation in AUTO mode is recommended irrespective of the requirement.



Remember to switch the system off when the ambient air suits your requirements.



ACCESSES

KEY

This locks and unlocks the locks on the vehicle and starts the engine.

REMOTE CONTROL

Unlocking



Press this button once to unlock the front doors.
Press this button again to unlock your vehicle completely.

The direction indicators flash twice.



Unlocking the load space



Press this button to unlock all of the rear doors.

Security of use

To unlock the load space only:



Press this control to lock the vehicle completely.



Press this control to unlock the load space, the front doors alone remain locked.

Central locking



Press this button to lock the vehicle completely.

The direction indicators flash once.

If one of the doors is open (transportation of long loads) or is not closed correctly, the central locking will not work.

Deadlocking

A second press on the closed padlock on the remote control within five seconds after locking changes the locking to deadlocking.

This is confirmed by fixed lighting of the direction indicators for approximately two seconds.

Deadlocking renders the exterior and interior door opening handles inoperative: do not leave anyone inside the vehicle when it is deadlocked.

If deadlocking is activated from inside the vehicle using the remote control, it will change to normal locking when the vehicle is started.

Accesses

Folding/unfolding the key



Press this button to release the key from its housing.

To fold the key, press this chromed button then fold the key into the housing.

If you do not press the button, the mechanism may be damaged.

Good practice

Take care not to allow the remote control to come into contact with grease, dust, rain or a damp environment.

A heavy object attached to the key (keyring, ...) weighing on the shaft of the key in the switch, may cause a malfunction.

REMOTE CONTROL

Changing the battery

Battery ref.: CR1620/3 volts.

The information "battery flat" is given by an audible signal, accompanied by a message on the display.

To replace the battery, unclip the casing using a coin at the ring.

If the remote control does not work after the battery has been changed, reprogramme the remote control.

There is a risk of damage if the replacement battery does not conform.



Use only identical batteries or batteries of an equivalent type to those recommended by CITROËN dealers.

Do not discard the remote control batteries, they contain metals which are harmful to the environment.

Deposit them at a CITROËN dealership, or at any other approved collection point.



Programming the remote control

Following changing of the remote control battery or disconnection of the vehicle battery, the remote control may have to be reprogrammed.

Wait at least one minute before using the remote control.

Insert the key in the ignition switch with the buttons (padlocks) of the remote control facing you.

Switch on the ignition.

Press the locking padlock for at least five seconds within the next ten seconds.

Switch off the ignition.

Wait at least one minute before using the remote control.

The remote control is now working again.

ELECTRONIC IMMOBILISER

All of the keys contain an electronic immobiliser device.

This device locks the engine supply system. It is activated automatically when the key is removed from the ignition.

After the ignition is switched on, a dialogue is established between the key and the electronic immobiliser system.

The metal part of the key must be unfolded correctly for correct dialogue to take place.

If you lose your keys

Visit a CITROËN dealer with the vehicle's V5 registration document and your identification document.

A CITROËN dealer will be able to retrieve the key code and the transponder code so that a replacement key can be ordered.

Good practice

Do not make any modifications to the electronic immobiliser system.

Operating the remote control, even when it is in your pocket, may result in involuntary unlocking of the doors.

The simultaneous use of other high frequency equipment (mobile telephones, domestic alarms...), may interfere with the operation of the remote control temporarily.

The remote control does not operate while the key is in the ignition, even if the ignition is off.

As a safety precaution (with children on board), remove the key from the ignition when leaving the vehicle, even for a short time.

When purchasing a second-hand vehicle:

- have the keys memorised by a CITROËN dealer to ensure that the keys in your possession are the only ones which can start the vehicle.



ALARM

If fitted on your vehicle, this provides two types of protection:

- exterior protection: it sounds if a front/rear door or the bonnet is opened.
- interior protection: it sounds if the volume inside the passenger compartment changes (breaking of a window or a movement inside the vehicle).

If your vehicle is fitted with a separation partition, the interior protection is not active in the load space.

Locking the vehicle with complete alarm

Setting the alarm

- Switch off the ignition and get out of the vehicle.
- Set the alarm within five minutes of getting out of the vehicle, by locking or deadlocking using the remote control. The red diode, located on the button, flashes once per second.

Disarming

- Unlock the vehicle with the remote control or switch on the ignition, the red diode goes out.

Locking the vehicle with exterior protection only

If, while you are away from the vehicle, you wish to leave a window partially open or a pet inside the vehicle, you should choose exterior protection only.

- Switch off the ignition.



- In the next ten seconds, press the button until the red diode is on continuously.
- Get out of the vehicle.
- Within the next five minutes, set the alarm by locking or deadlocking using the remote control (the red diode flashes once a second).

Triggering

The siren sounds, the direction indicators flash for approximately 30 seconds and the red diode flashes rapidly.

- To switch it off, insert the key and switch on the ignition.

When the alarm has been triggered ten times in succession (when triggered for the eleventh time) it is deactivated. Repeat the rules for setting the alarm.

Locking the vehicle without alarm

- Insert the key in the lock on the driver's door and lock it.

Do not set the alarm when washing your vehicle.

Failure of the remote control

When the alarm is set but the remote control does not operate:

- Unlock the doors with the key and open the door. The alarm is triggered.
- Switch on the ignition in the next ten seconds. The alarm is disarmed.

Incorrect operation

When the ignition is switched on, if the red diode remains on for ten seconds, there is a fault in the siren connection.

Contact a CITROËN dealer to have the system checked.

Automatic setting of the alarm

Depending on the country in which the vehicle is sold, the alarm is set automatically approximately 2 minutes after the last door is closed.

To prevent triggering of the alarm when a door is opened, it is imperative to press the remote control unlocking button again.



Do not make any modifications to the alarm system as this could cause faults.



FRONT DOORS From the outside

Use the remote control to lock/unlock the vehicle.

Insert the metal part of the key in the lock on the driver's side if the remote control does not work.



From the inside

Use the door opening control to unlock and open the door concerned.

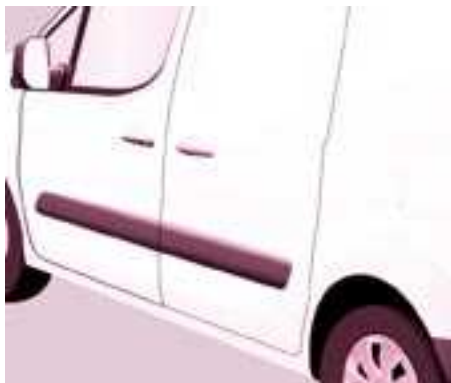

SLIDING SIDE DOOR

From the outside

Pull the handle towards you then towards the rear and open the side door, guiding the rearward sliding to beyond the point of resistance to hold it open.



From the inside

Unlock and open the side door using this handle, guiding the rearward sliding to the point of resistance. Pass this point to hold the door open.



Good practice

Take care not to block the guide space on the floor to allow the door to slide correctly.

If your vehicle is parked on a slope, guide the sliding of the side door. In fact, the door could open or close more rapidly due to the slope of the ground and could cause injury.

For safety and operation reasons, do not drive with the sliding side door open.



HINGED REAR DOORS

The hinged rear doors are asymmetrical (2/3 - 1/3), with the smaller door on the right. They are fitted with a central lock.

From outside

To open, pull the handle towards you.

Pull the lever to open the right-hand door.

To close, start with the right-hand door then close the left-hand door.

i With the roof rear flap, the rear bumper has been strengthened to serve as a footrest on accessing the vehicle.

Practice

It is possible to drive with the right-hand door open to make the transportation of long loads easier. The left-hand door is kept closed by the distinctive "yellow" lock, positioned at the base of the door. This closed door must not be used as a load retainer.

Driving with the right-hand door open is a special dispensation. Comply with the usual safety indications to attract the attention of other drivers.



Opening to approximately 180°

A check strap system permits extension of the opening from approximately 90° to approximately 180°.

Pull the yellow control when the door is open.

The check strap will re-attach automatically on closing.



From inside

Pull the handle towards you to open the left-hand door.



REAR ROOF FLAP

This rear roof flap is only compatible with the hinged doors.

To open the rear roof flap:

- raise the black paddle of the toggle,
- relieve the toggle by pressing the rear roof flap (downwards) then release the hook,
- lift the rear roof flap,
- pass the point of resistance to secure the rear roof flap using the support struts.

To close the rear roof flap:

- check that the support bar is secured correctly,
- lower the rear roof flap,
- while pressing the rear roof flap (downwards), take hold of the two loops of the spring then place the hook in its housing,



- lower the black paddle to secure the rear roof flap.

Securing the rear roof flap places it on the seal correctly and guarantees sealing without noise.

Support bar

A support bar is provided for transporting long loads, after opening the rear roof flap.

Fold back the support bar by lifting the lever.

Support it to the door pillar.

Support the long loads to be transported, lift them and reposition the support bar with one hand.

Ensure that it is secured correctly by pressing the handle downwards past the point of resistance and secure the loads firmly.

The side supports can be used as hooking points.

i The rear bumper has been strengthened to serve as a footrest on entering the vehicle.

e Never drive without the support bar in place.

The rear doors only lock when the support bar is installed.

When the rear roof flap is open, take care when driving where height is restricted.

Never rest loads directly on the rear doors.

Comply with the usual indications, to attract the attention of other drivers.



TAILGATE

From outside

Locking/unlocking is by means of the remote control.

To open, press the control below the trim then raise the tailgate.

A pull strap is available to close the tailgate in the high position.

Guide the closing of the tailgate to the balance point of its travel then apply a final press on the tailgate to close it fully.



From inside

Emergency control

In the event of a central unlocking operating fault, this permits unlocking of the tailgate from the inside.

Insert a small screwdriver in the opening, between the door and the floor. To unlock the lock, move the catch to the left then push the tailgate.



Tailgate screen

The opening rear screen allows you to access the rear of the vehicle directly, without having to open the tailgate.

Opening

After unlocking the vehicle using the remote control or the key, press the control and raise the rear screen to open it.

Closing

Close the rear screen by pressing the centre of the glass until it is fully closed.

The tailgate and tailgate screen cannot both be open at the same time, to prevent damage to the glass and the screen itself.



CENTRAL LOCKING

Cab and load space



An initial press permits central locking of the front and rear doors, when they are closed.

A second press permits central unlocking of the vehicle.

The control is inactive when the vehicle has been locked using the remote control or the key from the outside.

The control diode:

- flashes when the doors are locked with the vehicle stationary and the engine off,
- comes on when the doors are locked and from the time the ignition is switched on.

Load space



Press to lock/unlock the rear doors without changing the locking status of the cab. The doors can still be opened from the inside.

Protection against attack

Locking while driving

When the vehicle moves off, as soon as you reach approximately 6 mph (10 km/h), the system locks the doors. A noise characteristic of central locking is heard. The diode on the control on the fascia central control panel comes on.

During the journey, opening a door results in complete unlocking of the vehicle.

In the event of a serious impact, the doors are unlocked automatically to permit access by the emergency services.

Activating/deactivating the function



With the ignition on, press and hold this button to activate or deactivate the function.

Door open warning light



If this warning light comes on, check that all of your vehicle's doors are closed correctly.



INSTRUMENTS AND CONTROLS

INSTRUMENT PANEL

Dials

1. Distance recorder in kilometres/ miles.
2. Display.
3. Fuel level, coolant temperature.
4. Rev counter.
5. Trip distance recorder/service indicator zero reset.
6. Instrument panel lighting rheostat.



Displays

- Speed limiter/cruise control.
- Kilometres/Miles travelled.
- Service indicator, engine oil level indicator, total kilometres/miles.
- Presence of water in the diesel filter.
- Diesel pre-heating.

Screens

The information is presented on board the vehicle in different display formats according to the vehicle's equipment.



Instrument panel without display

ADJUSTING THE TIME

Centre console without display



To adjust the time of the clock, use the left-hand button on the instrument panel then carry out the operations in the following order:

- turn to the left: the minutes flash,
- turn to the right to increase the minutes (hold the button to the right for rapid scrolling),
- turn to the left: the hours flash,

- turn to the right to increase the hours (hold the button to the right for rapid scrolling),
- turn to the left: 24 H or 12 H is displayed,
- turn to the right to select 24 H or 12 H,
- turn to the left to complete the time adjustment.

After approximately 30 seconds without any action, the display returns to the normal display.

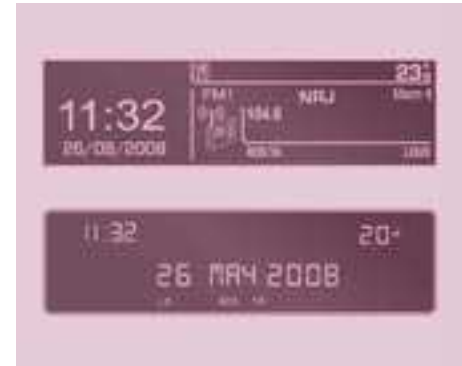

Centre console with display



The display - time sequence is linked according to model (version). The access to the "Date" adjustment is only active when the model version offers a date in words.





To adjust the time and date indicated on the display, refer to the "Adjusting the date and time" section of chapter 4.



WARNING LIGHTS





Each time the vehicle is started: a series of warning lights comes on applying a self-test check. They switch off almost immediately. When the engine is running: the warning light becomes a warning if it remains on continuously or flashes. This initial warning may be accompanied by an audible signal and a message which appears on the display.

Do not ignore these warnings.





Warning light		is	indicates	Solution - action
	STOP	lit, associated with another warning light and accompanied by a message on the display.	major faults linked with the "Brake fluid level", "Engine oil pressure and temperature", "Coolant temperature", "Electronic brake force distribution" and "Power steering" warning lights.	You must stop, park and switch off the ignition. Have the fault checked by a CITROËN dealer.
	Handbrake/ Brake fluid level/EBFD	lit.	that the handbrake is applied or has not been released fully.	Releasing the handbrake switches off the warning light.
		lit.	a low brake fluid level.	Top up using a fluid recommended by CITROËN.
		remaining on even though the level is correct and associated with the ABS warning light.	a failure of the electronic brake force distribution.	You must stop, park and switch off the ignition. Have the fault checked by a CITROËN dealer.
	Engine oil pressure and temperature	lit while driving.	insufficient pressure or a high temperature.	Park and switch off the ignition then allow to cool. Visually check the level. Chapter 7, "Levels" section.
		remaining on, even though the level is correct.	a major fault.	Have the fault checked by a CITROËN dealer.







Instruments and controls

Warning light		is	indicates	Solution - action
	Coolant temperature and level	lit with needle in the red zone.	an abnormal increase in temperature.	Park and switch off the ignition then allow to cool. Visually check the level.
		flashing.	a drop in the coolant level.	Chapter 7, "Levels" section. Consult a CITROËN dealer.
	Service	lit temporarily.	minor faults or warnings.	Consult the warnings log on the display or on the screen. If your vehicle is equipped with a trip computer or a screen: refer to the "Audio equipment - Trip computer" section of chapter 4. Consult a CITROËN dealer.
		remaining on.	major faults.	
	Driver's seat belt not fastened	lit then flashing.	the driver has not fastened his seat belt.	Pull the strap then insert the tongue in the buckle.
		accompanied by an audible signal then remains on.	the vehicle is moving with the driver's seat belt not fastened.	Check that the seat belt is fastened by pulling the strap. Chapter 5, "Seat belts" section.







Warning light		is	indicates	Solution - action
	Front/side air bag	flashing or remaining on.	a failure of an air bag.	Have the system checked by a CITROËN dealer without delay. Chapter 5, "Air bags" section.
	Front passenger air bag disarmed	lit.	the intentional disarming of this air bag in the presence of a rear-facing child seat.	Chapter 5, "Air bags-child safety" section.
	Low fuel level	lit with gauge needle in the red zone.	that the fuel reserve is being used.	Fill up with fuel without delay. The evaluation of the fuel reserve is a parameter which is sensitive to the style of driving, the profile of the road, the time elapsed and the distance travelled from the time the warning light comes on.
		flashing.	cutting off of the supply following a serious impact.	Restore the supply. Chapter 7, "Fuel" section.
	EOBD emission control system	flashing or remaining on.	a failure of the system.	There is a risk of damage to the catalytic converter. Have the system checked by a CITROËN dealer.
	Battery charge	lit.	a fault in the charging circuit.	Check the battery terminals, ... Chapter 8, "Battery" section.
		flashing.	placing of the active functions on standby (economy mode).	Chapter 8, "Battery" section.
		remaining on, in spite of the checks.	a faulty circuit, an ignition or injection malfunction.	Have the fault checked by a CITROËN dealer.

Instruments and controls

Warning light		is	indicates	Solution - action
	Power steering	lit.	a malfunction of the system.	The vehicle retains conventional steering without assistance. Have the system checked by a CITROËN dealer.
	Door open detection	lit and accompanied by a message on the display.	that a door is not closed correctly.	Check that all of the doors are closed.
	ABS	remaining on.	a failure of the anti-lock braking system.	The vehicle retains conventional braking. Consult a CITROËN dealer.
	ESP	flashing.	triggering of the ASR or ESP regulation.	The system optimises drive and permits improvement of the directional stability of the vehicle. Chapter 5, "Driving safety" section.
		remaining on.	a malfunction of the system. E.g.: under-inflation of the tyres.	E.g.: check the pressure of the tyres. Have the system checked by a CITROËN dealer. (Wheel speed sensor, hydraulic block, ...).
		remaining on with the diode on the button (on the fascia) lit.	deactivation of the system at the request of the driver.	Operation of the system is deactivated. Reactivation is automatic above 30 mph (50 km/h) or after pressing the button (on the fascia).

Warning light	is	indicates	Solution - action
 Particle emission filter	lit.	a malfunction of the particle emission filter (diesel additive level, risk of clogging, ...).	Have the filter checked by a CITROËN dealer. Chapter 7, "Levels" section.
 Dipped headlamps/Daytime lights	lit.	a manual selection or automatic lighting.	Turn the ring on the lights stalk to the second position.
		lighting of the dipped headlamps from the time the ignition is switched on: daytime lights (depending on the country in which the vehicle is sold).	Chapter 3, "Steering wheel controls" section.
 Main beam headlamps		pulling of the stalk towards you.	Pull the stalk to return to dipped headlamps.
 Direction indicators	flashing with buzzer.	a change of direction via the lights stalk, to the left of the steering wheel.	To the Right: control to be pushed upwards. To the Left: control to be pushed downwards.
 Front fog lamps	lit.	a manual selection.	The fog lamps only operate if the side lights or dipped headlamps are on.
 Rear fog lamps	lit.	a manual selection.	The fog lamps only operate if the side lights or dipped headlamps are on. In conditions of normal visibility, take care to switch them off on penalty of being booked. "This light is a dazzling red."

Instruments and controls

Warning light on the display		is	indicates	Solution - action
	Cruise control	lit.	cruise control selected.	Manual selection. Chapter 3, "Steering wheel controls" section.
	Speed limiter	lit.	speed limiter selected.	Manual selection. Chapter 3, "Steering wheel controls" section.
	Diesel pre-heating	lit.	climatic conditions requiring pre-heating.	Wait until the warning light is switched off before operating the starter.
	Presence of water in the diesel filter	lit and accompanied by a message on the display.	water in the diesel filter.	Have the filter bled by a CITROËN dealer without delay. Chapter 7, "Checks" section. According to country.
	Service spanner	lit.	that a service will be due shortly.	Refer to the list of checks in the servicing booklet. Have the service carried out by a CITROËN dealer.
	Time	flashing.	adjustment of the time.	Use the left-hand button on the instrument panel. Chapter 2, at the beginning of the "Instruments and controls" section.



FUEL GAUGE

The fuel level is tested each time the key is turned to the "running" position.

The gauge is positioned on:

- **1**: the fuel tank is full, approximately 60 litres.
- **0**: the reserve is now being used, the warning light comes on continuously. The reserve when the warning first comes on is approximately 8 litres.



Refer to the "Fuel" section of chapter 7.



COOLANT TEMPERATURE

The needle is positioned between the blue zone and the red zone: normal operation.

In arduous conditions of use or hot climatic conditions, the needle may move close to the red graduations.

What you should do if the needle enters the red zone:

Reduce your speed or let the engine run at idle.

What you should do if the warning light comes on:

- stop immediately, switch off the ignition. The fan may continue to operate for a certain time up to approximately 10 minutes.
- wait for the engine to cool down in order to check the coolant level and top it up if necessary.

As the cooling system is pressurised, follow this advice in order to avoid any risk of scalding:

- wait at least one hour after switching off the engine before carrying out any work,
- unscrew the cap by 1/4 turn to allow the pressure to drop,
- when the pressure has dropped, check the level on the expansion bottle,
- if necessary, remove the cap to top up.

If the needle remains in the red zone, have the system checked by a CITROËN dealer.



Refer to the "Levels" section of chapter 7.

EMISSION CONTROL



EOBD (European On Board Diagnosis) is a diagnostics system which complies with, among others, the standards concerning authorised emissions of:

- CO (carbon monoxide),
- HC (unburnt hydrocarbons),
- NOx (nitrogen oxides) or particles, detected by oxygen sensors placed upstream and downstream of the catalytic converters.

Therefore, the driver is warned of any malfunction of this emission control system by the lighting of this specific warning light on the instrument panel.

There is a risk of damage to the catalytic converter. Have it checked by a CITROËN dealer.

TYRE UNDER-INFLATION DETECTION

Sensors check the tyre pressure during driving (speed higher than 12 mph [20 km/h]) and trigger a warning in the event of a malfunction or puncture.



Any anomaly detected (flat or punctured tyre, malfunction of a sensor) is indicated by visual and audible information and is accompanied by a message on the display.

Flat tyre

Check the tyre pressure as soon as possible.

Puncture

Stop immediately, avoiding any sudden movement of the steering wheel and the brakes.

Change the damaged (punctured or very deflated) tyre, and have the tyre pressure checked as soon as possible.



Refer to the "Changing a wheel" section of chapter 8.

If the damaged tyre is temporarily stored inside the vehicle, it will again emit this message to remind you of the necessity of having it repaired. This will prevent another warning of the same type being displayed.

Sensor(s) not detected

Under-inflation detection is absent from one (or several) tyre(s). Contact a CITROËN dealer to replace the faulty sensor(s).

This message is also displayed when one of the tyres is away from the vehicle (being repaired) or when a wheel without a sensor is fitted.

All repairs and changing of tyres on a wheel fitted with this system must be carried out by a CITROËN dealer.

The tyre under-inflation detection system is a driving aid which does not take the place of vigilance or the responsibility of the driver.

This system does not remove the need to have the tyre pressure checked regularly (including the spare wheel), to ensure that the dynamic performance of the vehicle remains at its best and to avoid premature wear of the tyres, in particular in the case of arduous driving (heavy load, high speed).

The system may temporarily be disturbed by radio broadcasts on a frequency close to it.

SERVICE INDICATOR

This programme's service intervals according to the use of the vehicle.

Operation

A few moments after the ignition has been switched on, the spanner indicating a service operation lights up; the display for the total distance recorder tells you (in round figures) the distance remaining before the next service.

The points at which a service is due are calculated from the last indicator zero reset.

The point at which a service is due is determined by two parameters:

- the distance travelled,
- the time which has elapsed since the last service.

i The distance remaining before the next service may be weighted by the time factor, depending on the driver's driving habits.

More than 1 000 miles/km before the next service is due

Example: 4 800 miles/km remain before the next service is due. When the ignition is switched on and for a few seconds, the display shows:



A few seconds after the ignition is switched on, the oil level is displayed, then the total distance recorder resumes normal operation showing the total and trip distances.

Less than 1 000 miles/km before the next service is due

Each time the ignition is switched on and for a few seconds, the spanner flashes and the number of miles/kilometres remaining is displayed:

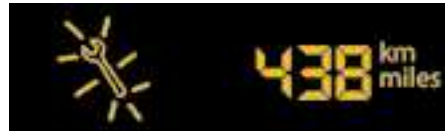

A few seconds after the ignition is switched on, the oil level is displayed, then the total distance recorder resumes normal operation and the spanner remains lit. This indicates that a service should be carried out shortly.

Service overdue



Each time the ignition is switched on and for a few seconds, the spanner flashes and the excess distance is displayed.

i With the engine running the spanner remains lit until the service has been carried out.

First of the two terms reached: the spanner also lights up if the two-year interval has elapsed.

Zero re-set

Your CITROËN dealer carries out this operation after each service.

However, if you carry out the service yourself, the re-set procedure is as follows:

- switch off the ignition,
- press and hold the trip recorder reset button,
- switch on the ignition.

The display begins a countdown.

When the display shows "**=0**", release the button; the spanner disappears.

 After this operation, if you wish to disconnect the battery, lock the vehicle and wait for at least five minutes, otherwise the zero re-set will not be registered.

Engine oil level indicator

When the ignition is switched on, the engine oil level is indicated for a few seconds, after the service information.



Oil level correct



Lack of oil

Flashing of "OIL", linked with the service warning light, accompanied by an

audible signal and a message on the display, indicates a lack of oil which could damage the engine.

If the lack of oil is confirmed by a check using the dipstick, it is essential that the level is topped up.



Oil level gauge fault

Flashing of "OIL--" indicates a malfunction of the engine oil level gauge.

Consult a CITROËN dealer.



The level read will only be correct if the vehicle is on level ground and the engine has been off for more than 15 minutes.



Dipstick

A = maximum, never exceed this level as a surplus of oil may damage the engine.

Contact a CITROËN dealer without delay.

B = minimum, top up the level via the oil filler cap, using the type of oil suited to your engine.

Trip recorder zero reset button



With the ignition on, press the button until the zeros appear.

Lighting rheostat



With the lights on, press the button to vary the intensity of the lighting of the instruments and controls. When the lighting reaches the minimum (or maximum) setting, release

the button then press it again to increase (or reduce) the brightness.

As soon as the lighting is of the required brightness, release the button.



5-speed - reverse gear gearbox

GEARBOX

To change gear easily, always press the clutch pedal fully.

To prevent the mat from becoming caught under the pedal:

- ensure that the mat and its fixings on the floor are positioned correctly,
- never fit one mat on top of another.

When driving, avoid leaving your hand on the gear knob as the force exerted, even if slight, may wear the internal components of the gearbox over time.

To engage reverse gear, wait until the vehicle is stationary then push the gear lever to the right then down.

The lever should be moved slowly to reduce the noise on engaging reverse gear.



STEERING WHEEL ADJUSTMENT

When the vehicle is stationary, unlock the steering wheel by pulling the lever.

Adjust the height and depth of the steering wheel, then lock by pushing the lever fully.

Starting and stopping



STARTING AND STOPPING

Running and accessories position.

To unlock the steering, turn the steering wheel gently while turning the key, without forcing. In this position, certain accessories can be used.

Starting position.

The starter is operated, the engine turns over, release the key.

STOP position: steering lock.

The ignition is off. Turn the steering wheel until the steering locks. Remove the key.

Good practice when starting



Door or bonnet open warning light

If this comes on, a door or the bonnet is not closed correctly, check!



Diesel pre-heating warning light

If the temperature is high enough, the warning light comes on for less than one second, you can start without waiting.

In cold weather, wait for this warning light to switch off then operate the starter (Starting position) until the engine starts.

Good practice when stopping

Minimise engine and gearbox wear

When switching off the ignition, let the engine run for a few seconds to allow the turbocharger (Diesel engine) to return to idle.

Do not press the accelerator when switching off the ignition.

There is no need to engage a gear after parking the vehicle.

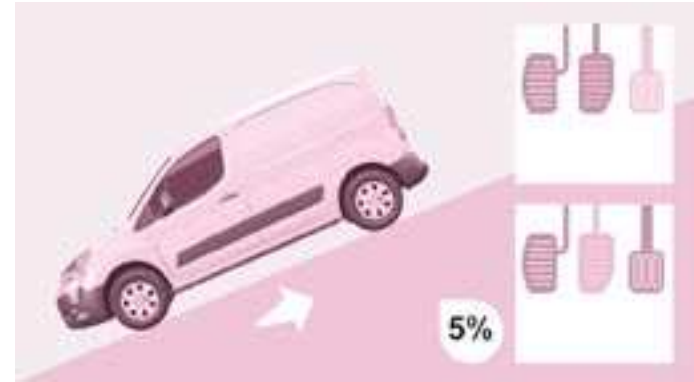
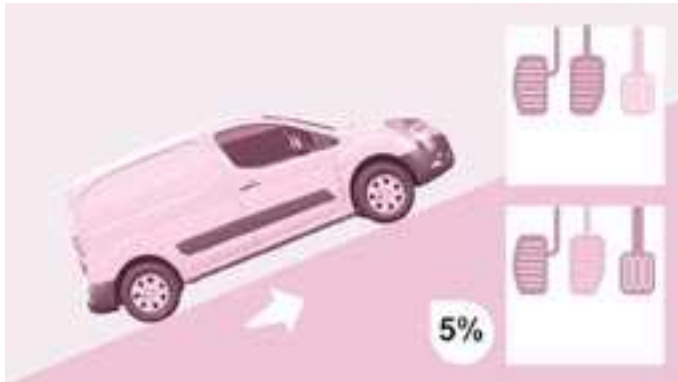

HILL START ASSISTANCE

This function, linked with the ESP, makes hill starts easier and is activated in the following conditions:

- the vehicle must be stationary, engine running, foot on the brake,
- the gradient of the road must be steeper than 5 %,
- uphill, the gearbox must be in neutral or in a gear other than reverse,
- downhill, reverse gear must be engaged.

Operation

With the brake pedal and clutch pedal pressed, from the time you release the brake pedal you have approximately 2 seconds before the vehicle starts to roll back and without using the handbrake within which to move off. During the moving off phase, the function is deactivated automatically, gradually releasing the braking pressure. During this phase, the typical noise of mechanical disengaging of the brakes can be heard, indicating the imminent movement of the vehicle.

The hill start assistance is deactivated in the following situations:

- when the clutch pedal is released,
- when the handbrake is applied,
- when the engine is switched off,
- when the engine stalls.

Anomaly



If a malfunction of the system occurs, this warning light comes on accompanied by an audible signal and confirmed by a message on the display. Contact a CITROËN dealer to have the system checked.

Steering wheel controls

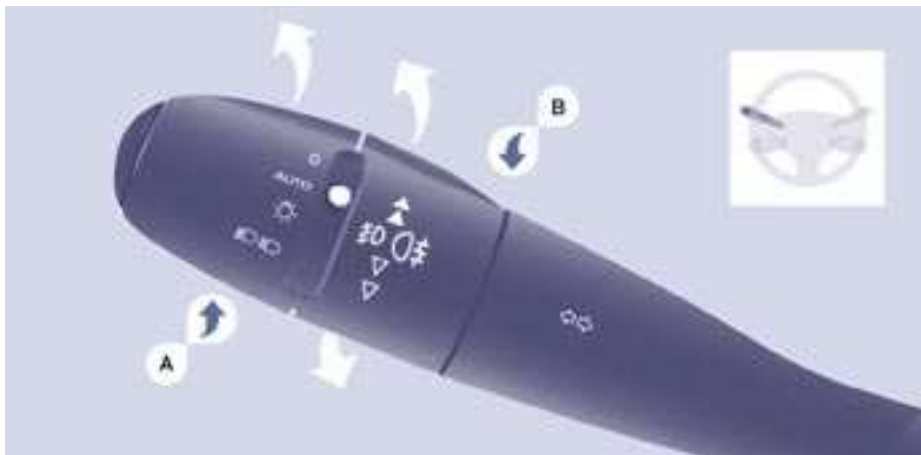

DIRECTION INDICATORS (green flashing)



Left: downwards passing the point of resistance.

Right: upwards passing the point of resistance.

"Motorway" function

Press the control up or down to flash the corresponding direction indicator three times.

LIGHTING CONTROL

Front and rear lights

Selection is by turning ring **A**.



Checking by means of the indicator lights on the instrument panel is described in the "Instruments and controls" section of chapter 2.



Lights off

AUTO

Automatic lights



Side lights



Dipped beam (green)
Main beam (blue)

Dipped beam/main beam change

Pull the stalk fully towards you.

Lights-on buzzer

When the ignition is switched off, when the driver's door is opened, a buzzer sounds if you have left your lights on.

Steering wheel controls

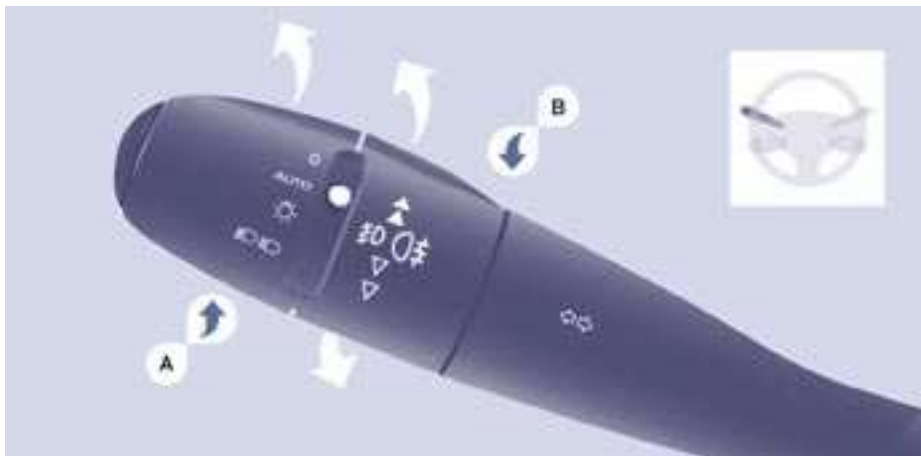

DIRECTION INDICATORS (green flashing)



Left: downwards passing the point of resistance.

Right: upwards passing the point of resistance.

"Motorway" function

Press the control up or down to flash the corresponding direction indicator three times.

LIGHTING CONTROL

Front and rear lights

Selection is by turning ring **A**.



Checking by means of the indicator lights on the instrument panel is described in the "Instruments and controls" section of chapter 2.



Lights off

AUTO

Automatic lights



Side lights



Dipped beam (green)
Main beam (blue)

Dipped beam/main beam change

Pull the stalk fully towards you.

Lights-on buzzer

When the ignition is switched off, when the driver's door is opened, a buzzer sounds if you have left your lights on.

Front and rear fog lamps

Rotate ring **B** forwards to switch on and rearwards to switch off. The status is confirmed by the light on the instrument panel.

These operate with the side lights and the dipped beam headlamps.



Front fog lamps (green, 1st rotation of the ring forwards).



Rear fog lamps (amber, 2nd rotation of the ring forwards).

To switch off the front and rear fog lamps, turn the ring rearwards twice in succession.

In clear weather or in rain, both day and night, rear fog lamps dazzle and are prohibited.

i Do not forget to switch them off when they are no longer needed. Automatic switching on of the lights switches off the rear fog lamps, but the front fog lamps remain on.

Daytime lights

Depending on the country in which the vehicle is sold, the vehicle may be equipped with daytime lights. The dipped headlamps come on when the vehicle is started.



This warning light comes on on the instrument panel.

i The instruments and controls (instrument panel, display, air conditioning control panel, ...) are only lit on switching to the automatic switching on of the lights mode or when the lights are switched on manually.

Automatic switching on of the lights



The side lights and dipped beam headlamps switch on automatically if the light is poor, or during operation of the windscreen wipers. They switch off as soon as the light becomes bright enough or the windscreen wipers stop.

This function is not compatible with the daytime lights.

i In foggy weather or in snow, the brightness sensor can detect sufficient light. As a consequence, the lights will not come on automatically. If necessary, you must switch on the dipped headlamps manually.

i Do not cover the brightness sensor located on the windscreen, behind the mirror. It is used for the automatic switching on of the lights and for the automatic wipers.

Activation

Turn the ring to the **AUTO** position. The activation of this function is accompanied by a message on the display.

Deactivation

Turn the ring forwards or rearwards. The deactivation of this function is accompanied by a message on the display.

The function is deactivated temporarily when you use the manual lights stalk.

Steering wheel controls



If the brightness sensor does not function correctly, the lights come on accompanied by the service warning light, an audible signal and a message on the display.

Consult a CITROËN dealer.

Follow-me-home lighting

The temporary maintaining of the dipped headlamps lighting, with the ignition off, makes the driver's exit easier when the light is poor.

Manual operation

- With the ignition off, "flash" the headlamps within one minute after switching off the ignition.

The follow-me-home lighting switches off automatically after a set time.

Automatic operation



Activate the function via the "Vehicle config" menu.

+ Refer to the "Display flow chart" section of chapter 4.



HEADLAMP BEAM

Depending on the load in your vehicle, the beam setting must be adjusted.

- 0** - No load.
- 1** - Partial load.
- 2** - Average load.
- 3** - Maximum authorised load.

Initial setting is position 0.

Steering wheel controls



If the brightness sensor does not function correctly, the lights come on accompanied by the service warning light, an audible signal and a message on the display.

Consult a CITROËN dealer.

Follow-me-home lighting

The temporary maintaining of the dipped headlamps lighting, with the ignition off, makes the driver's exit easier when the light is poor.

Manual operation

- With the ignition off, "flash" the headlamps within one minute after switching off the ignition.

The follow-me-home lighting switches off automatically after a set time.

Automatic operation



Activate the function via the "Vehicle config" menu.

+ Refer to the "Display flow chart" section of chapter 4.



HEADLAMP BEAM

Depending on the load in your vehicle, the beam setting must be adjusted.

- 0** - No load.
- 1** - Partial load.
- 2** - Average load.
- 3** - Maximum authorised load.

Initial setting is position 0.

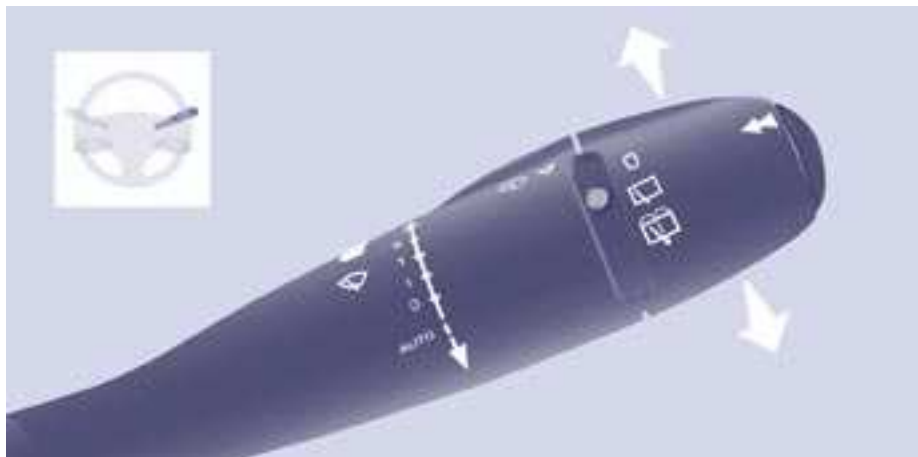

WINDSCREEN WIPER STALK

Manual windscreen wipers

- 2 Fast wipe (heavy rain).
- 1 Normal wipe (moderate rain).
- 1 Intermittent wipe.
- 0 Off.
- ↓ Single wipe (press downwards).

In the Intermittent position, the wiping speed is in proportion to the vehicle speed.

Whenever the ignition has been switched off for more than one minute, with the windscreen wiper stalk in position 2, 1 or 1, the stalk must be reactivated:

- move the stalk to any position,
- then move it back to the required position.

Automatic windscreen wipers



Do not cover the rain sensor, located in the centre of the windscreen, behind the mirror.

In the **AUTO** position, the windscreen wipers operate automatically and adapt their speed to the intensity of the rainfall. When not in **AUTO** mode, for the other positions, refer to the manual windscreen wipers section.

Activation

Press the control downwards. Activation of the function is accompanied by a message on the display.

The automatic windscreen wipers function must be reactivated if the ignition has been switched off for more than one minute, by pressing the stalk downwards.

Deactivation/Switching off

Place the windscreen wipers stalk in position 1, 1 or 2. Deactivation of the function is accompanied by a message on the display.

In the event of malfunction of the automatic windscreen wipers, the windscreen wipers will operate in intermittent mode.

Contact a CITROËN dealer to have the system checked.



When using an automatic car wash, switch off the ignition to avoid triggering of the automatic wiping.

In winter, it is advisable to wait for the windscreen to completely clear of ice before operating the automatic wipe.

Steering wheel controls

Wash-wipe and headlamp wash

Pull the stalk towards you, the wash-wipe is accompanied by a timed sweep of the wipers.

The headlamp wash is linked with the wash-wipe, it is triggered if the dipped headlamps are on.

 To top up the levels, refer to the "Levels" section of chapter 7.

Special position of the windscreen wipers

In the minute following switching off of the ignition, any action on the stalk positions the wipers against the windscreen uprights.

This action enables you to position the wiper blades for winter parking, cleaning or replacement.

 Refer to the "Changing a windscreen wiper blade" section of chapter 8.

To park the wipers in their normal position after this has been done, switch on the ignition and move the stalk.

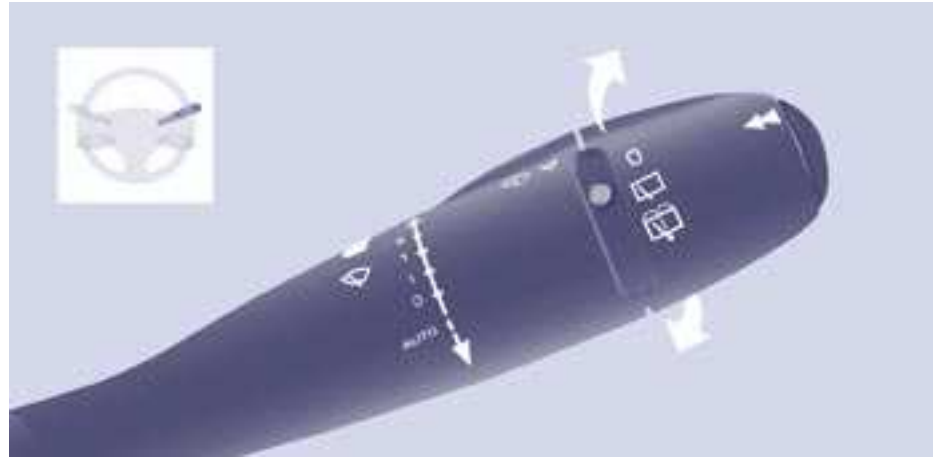

Rear windscreen wiper



Turn the ring to the first notch.

Rear windscreen wash



Turn the ring past the first notch: the windscreen wash then the windscreen wiper operate for a fixed time.

 In winter, in the event of a considerable amount of snow or ice, switch on the rear screen demister. Once de-icing is complete, remove the snow or ice which has accumulated on the rear wiper blade. You can then operate the rear windscreen wiper.



CRUISE CONTROL "CRUISE"

"This is the speed at which the driver wishes to drive".

This aid to driving in free-flowing traffic enables the vehicle to maintain the speed programmed by the driver, unless a steep gradient makes this impossible.

In order for it to be programmed or activated, the vehicle speed must be greater than 25 mph (40 km/h) with at least 4th gear engaged.

This cruise control shows the function selection status on the instrument panel and displays the programmed speed:



Function selected, displaying of the "Cruise Control" symbol.



Function deactivated, **OFF** (example at 107 km/h).



Function activated (example at 107 km/h).



Vehicle speed above (e.g. 118 km/h), the programmed speed is displayed flashing.



Operating fault detected, **OFF** - the dashes flash.

Steering wheel controls



Selecting the function

- Place the switch in the **CRUISE** position. The cruise control is selected but is not yet active and no speed has been programmed.



First activation/ programming a speed

- Reach the chosen speed by pressing the accelerator.
- Press the **SET -** or **SET +** button.



This programmes/activates the reference speed and the vehicle will maintain this speed.



Temporary exceeding of the speed

It is possible to **accelerate** and drive momentarily at a speed greater than the programmed speed. The value programmed flashes.

When the accelerator pedal is released, the vehicle will return to the programmed speed.



Deactivation (off)

- Press this button or the brake or clutch pedal.



Reactivation

- Following deactivation of the cruise control, press this button. Your vehicle will return to the last programmed speed. Alternatively, you can repeat the "first activation" procedure.



Changing the programmed speed

There are two methods of memorising a speed higher than the previous one:

Without using the accelerator:

- press the **Set +** button.

A brief press increases the speed by 1 mph (km/h).

A maintained press increases the speed in steps of 5 mph (km/h).

Using the accelerator:

- exceed the memorised speed until the speed required is reached,
- press the **Set +** or **Set -** button.

To memorise a speed lower than the previous one:

- press the **Set -** button.

A brief press decreases the speed by 1 mph (km/h).

A maintained press decreases the speed in steps of 5 mph (km/h).



Switching the function off

- Place the dial in position **0** or switch off the ignition to switch everything off.

Cancelling the programmed reference speed

When the vehicle becomes stationary, after switching off the ignition, the system no longer memorises a speed.



Operating fault

The programmed speed is cleared then replaced by three dashes. Contact a CITROËN dealer to have the system checked.

Good practice

When changing the programmed reference speed by means of a maintained press, pay attention as the speed can increase or decrease rapidly.

Do not use the cruise control on slippery roads or in heavy traffic.

In the event of a steep slope, the cruise control cannot prevent the vehicle from exceeding the programmed speed.

In any event, the cruise control cannot replace the need to observe the speed limits, nor can it replace the need for vigilance and responsibility on the part of the driver.

It is advisable to leave your feet near the pedals.

To avoid any jamming under the pedals:

- ensure that the mat and its fixings on the floor are positioned correctly,
- never place one mat on top of another.



SPEED LIMITER "LIMIT"

"This is the selected speed which the driver does not wish to exceed".

This selection is made with the engine running while stationary or with the vehicle moving. The minimum speed which can be programmed is 20 mph (30 km/h).

The speed of the vehicle responds to the pressure of the driver's foot as far as the accelerator pedal point of resistance which indicates that the programmed speed has been reached.

However, pressing the pedal beyond this point of resistance to the floor permits exceeding of the programmed speed. To resume use of the limiter, simply reduce the pressure on the accelerator pedal gradually and return to a speed below that programmed.

The operating actions may be carried out when stationary, with the engine running, or with the vehicle moving.

This speed limiter shows the function selection status on the instrument panel and displays the programmed speed:



Function selected, displaying of the "Speed Limiter" symbol.



Function deactivated, last programmed speed - OFF (example at 65 mph (107 km/h)).



Function activated (example at 65 mph (107 km/h)).



Vehicle speed above (example 70 mph (118 km/h)), the programmed speed is displayed flashing.



Operating fault detected, **OFF** - the dashes flash.



Selecting the function

- Place the dial in the **LIMIT** position. The limiter is selected but is not yet active. The display indicates the last programmed speed.

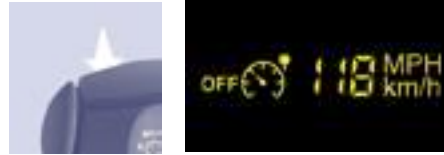

Programming a speed

A speed can be programmed without activating the limiter but with the engine running.

To memorise a speed higher than the previous one:

- press the **Set +** button.

A brief press increases the speed by 1 mph (km/h).

A maintained press increases the speed in steps of 5 mph (km/h).

To memorise a speed lower than the previous one:

- press the **Set -** button.

A brief press decreases the speed by 1 mph (km/h).

A maintained press decreases the speed in steps of 5 mph (km/h).

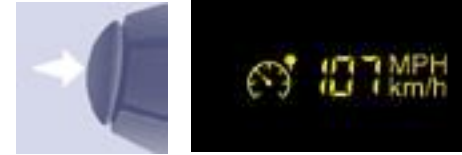

Activation/Deactivation (off)

Pressing this button once activates the limiter, pressing the button again deactivates it (OFF).





Exceeding the programmed speed

Pressing the accelerator pedal in order to exceed the programmed speed will have no effect unless you press the pedal **firmly** beyond the **point of resistance**.

The limiter is deactivated temporarily and the programmed speed flashes.

To return to the limiter function, reduce your speed to below the programmed speed.

Flashing of the speed

The speed flashes:

- following forcing of the accelerator point of resistance,
- when the limiter cannot prevent an increase in the vehicle speed due to the profile of the road or on a steep descent,
- in the event of sharp acceleration.

Switching the function off

- Place the dial in position **0** or switch off the ignition to switch the system off.

The last programmed speed remains in the memory.

Operating fault

The programmed speed is cleared then replaced by three dashes.

Contact a CITROËN dealer to have the system checked.

Good practice

In any event, the speed limiter cannot replace the need to observe speed limits, nor can it replace the need for vigilance and responsibility on the part of the driver.

Always pay attention to the profile of the road and sharp acceleration and stay in complete control of your vehicle.

To avoid any jamming under the pedals:

- ensure that the mat and its fixings on the floor are positioned correctly,
- never place one mat on top of another.



Heating control panel



Air conditioning control panel

VENTILATION

Manual adjustments:

Temperature



Control positioned: in the blue zone, triggers cool air,



in the red zone, triggers heating of the interior ambient air.

Air flow



The force of the blown air at the vents varies from 1 to the strongest 4. Position 0 switches it off.

Remember to adjust this control in order to reach the ambient air comfort level.

Air distribution

The air supply distribution is determined by the following symbols:



the side vents and the central vents,



the footwells,



the windscreen and the footwells,



the windscreen.



The air distribution can be modulated by placing the control in the intermediate positions, marked "•".

Ventilation

Intake of exterior air



The diode on the button is off. This is the preferred operating position.

Recirculation of interior air



The diode on the button is lit. Recirculation temporarily prevents exterior odours and smoke from entering the passenger compartment.

Used with the setting of the force of blown air (from 1 to 4), recirculation enables you to obtain the required ambient air comfort level more quickly with both hot or cold settings.

This position should only be temporary. When your ambient air comfort level has been reached, return to the intake of exterior air position to permit renewal of the air in the passenger compartment and avoid misting. This operating mode is preferable.

Air conditioning A/C

The air conditioning can only operate with the engine running.



Pressing the button triggers the operation of the air conditioning, the diode is lit. Pressing the button again switches the function off and the diode is switched off.

The air conditioning does not operate if the air flow is set to 0.



DE-ICING AND DEMISTING

Manual mode



Direct the control to this air distribution setting.



Direct the control to this temperature setting.



Increase the air flow setting.



Press the air conditioning.



Returning to exterior air intake open permits renewal of the air in the passenger compartment (diode off).

De-icing the rear screen and/or mirrors



Pressing this button, with the engine running, activates the rapid demisting - de-icing of the rear screen and/or electric mirrors.

This function switches off:

- when the button is pressed,
- when the engine is switched off,
- automatically to prevent excessive energy consumption.



AUTOMATIC AIR CONDITIONING WITH SEPARATE ADJUSTMENTS FOR THE DRIVER AND PASSENGER

Good practice

For maximum cooling or heating of the passenger compartment, it is possible to exceed the value 15 by turning until LO is displayed or the value 27 by turning until HI is displayed.

On entering the vehicle, the inside temperature may be much colder (or warmer) than is comfortable. There is no advantage in changing the value displayed in order to quickly reach the level of comfort required. The system will use its maximum performance to reach the comfort value set.

Automatic operation

AUTO comfort programme

This is the normal air conditioning system operating mode.

AUTO Press this button, the **AUTO** symbol is displayed. In accordance with the comfort value selected, the system controls the distribution, the flow and the intake of air to guarantee comfort and a sufficient circulation of air in the passenger compartment. No further action on your part is required.

When the engine is cold, to prevent an excessive diffusion of cold air, the air diffuser will reach its optimum level gradually.

For your comfort, the settings are stored when the ignition is switched off and are reinstated the next time the vehicle is started.

The automatic function will no longer be maintained if you change a setting manually (AUTO is cleared).

Driver or passenger side comfort value

The value indicated on the display corresponds to a level of comfort and not a temperature in degrees Celsius or Fahrenheit.



Turn this control to the left or to the right to decrease or increase the value. A setting around the value 21 provides optimum comfort. However, depending on your requirements, a setting between 18 and 24 is usual.



Do not cover the sunshine sensor located on the fascia.

Manual operation

You can, according to your requirements, make a different selection from that offered by the system by changing a setting. The other functions will still be controlled automatically. Pressing the **AUTO** button restores fully automatic operation.



Air distribution

Pressing this button several times in succession directs the air flow towards:

- the windscreen,
- the windscreen and footwells,
- the footwells,
- the side vents, central vents and footwells,
- the side vents and central vents.



Air flow

Press the **small fan** button to reduce the flow or the **large fan** button to increase the flow.

On the display, the blades of the fan fill when the flow is increased.



Deactivating the system

Press the air flow **small fan** button until the fan symbol disappears from the display.

This action deactivates all of the system's functions, with the exception of the air recirculation and rear screen demisting (if fitted on your vehicle). Your comfort setting is no longer maintained and is switched off.

For your comfort, do not deactivate the system for long periods.



Pressing the **large fan** button or the **AUTO** button reactivates the system with the values set before it was deactivated.



Intake of exterior air/ Recirculation of interior air

Press this button to recirculate the interior air. The recirculation symbol is displayed.

Recirculation prevents exterior odours and smoke from entering the passenger compartment. Avoid prolonged operation in interior air recirculation mode (risk of condensation, odour and humidity).

Pressing this button again activates the intake of exterior air.



Switching the air conditioning On/Off

Press this button, the **A/C** symbol is displayed and the air conditioning is activated.

Pressing this button again switches off the air cooling.



The ventilation outlet, located in the glove box, diffuses cool air (if the air conditioning is on) regardless of the reference temperature requested in the passenger compartment and regardless of the exterior temperature.



DE-ICING AND DEMISTING

Automatic mode: visibility programme

The comfort programme (AUTO) may not be sufficient to quickly demist or de-ice the windows (humidity, several passengers, ice).

In this case, select the visibility programme. The visibility programme indicator light comes on.

It activates the air conditioning, the air flow and provides optimum distribution of the ventilation to the windscreen and side windows.

It deactivates the air recirculation.

GOOD PRACTICE

Vents

"Leave them open"

For optimum distribution and diffusion of hot or cool air in the passenger compartment, there are adjustable central and side vents which can be directed sideways (right or left) or vertically (up or down). For your comfort while driving, do not close them and direct the flow of air towards the windows instead.

Air vents in the footwells and directed towards the windscreen complete the equipment.

Do not block the vents located at the windscreen or the air extractor located in the boot.

Dust filter, odour filter (activated carbon)

This filter traps certain dust and limits odours.

Ensure that this filter is in good condition and have all of the filter elements replaced regularly.



Refer to the "Checks" section of chapter 7.

Air conditioning

In all seasons, the air conditioning should only be used with the windows closed. However, if the interior temperature remains high after a prolonged period parked in the sun, do not hesitate to ventilate the passenger compartment for a few minutes.

Use the AUTO mode as much as possible as it permits optimised control of all of the functions: air flow, passenger compartment comfort temperature, air distribution, air intake mode or air recirculation in the passenger compartment.

Operate the air conditioning system for 5 to 10 minutes, once or twice a month, to keep it in perfect working order.

It is normal that the condensation created by the air conditioning system results in a flow of water which may form a puddle under the vehicle when parked.

If the system does not produce cold air, do not use it and contact a CITROËN dealer.



FRONT SEATS

Depending on the version and configuration of your vehicle, different front seats are fitted, either:

- a driver's seat and a passenger seat,
- an individual driver's seat and a modular bench.

Depending on the models, the following adjustments are available:



1 - Forwards/backwards adjustment

Lift the bar and slide the seat forwards or backwards.



2 - Seat back angle adjustment

With your back pressed against the seat back, move the lever forward and set the required angle.



3 - Driver's seat height adjustment

To raise the seat, pull the handle upwards then take your weight off the seat cushion.

To lower the seat, pull the handle upwards then push on the seat cushion.



Head restraint height adjustment

To raise the head restraint, slide it vertically upwards.

To lower the head restraint, press the button and slide the head restraint vertically downwards.

The adjustment is correct when the upper edge of the head restraint is level with the top of the head.

To remove the head restraint, press the button and pull the head restraint upwards.

To re-install, engage the head restraint rods in the holes, making sure they are aligned with the seat back.



Never drive with the head restraints removed; they must be in place and correctly adjusted.

Armrest

To access the vertical position, raise the armrest until it locks.

Lower the armrest to put it back in the position for use.

To remove the armrest, press the release button from the vertical position and move aside the armrest.

To put the armrest back in place, clip it in the vertical position.

If the vehicle is fitted with the additional console and an armrest, to fold the passenger seat to the table position remove the console or the armrest.

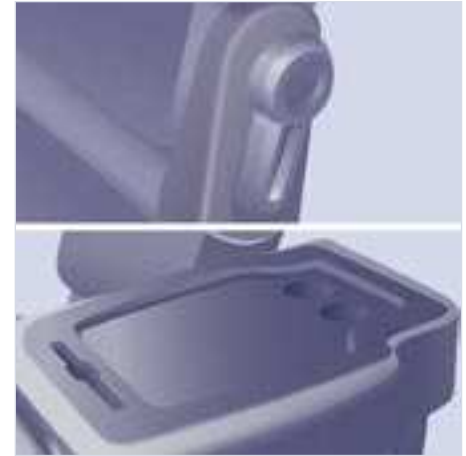

PASSENGER SEAT

The back of the individual passenger seat can be folded to form a writing table.

This position also permits the transportation of long loads.

Folding the seat back

Pull the lever forwards then tilt the seat back.

Returning the seat back to its original position

Pull the lever forwards then raise the seat back until it locks.



Head restraint height adjustment

To raise the head restraint, slide it vertically upwards.

To lower the head restraint, press the button and slide the head restraint vertically downwards.

The adjustment is correct when the upper edge of the head restraint is level with the top of the head.

To remove the head restraint, press the button and pull the head restraint upwards.

To re-install, engage the head restraint rods in the holes, making sure they are aligned with the seat back.



Never drive with the head restraints removed; they must be in place and correctly adjusted.

Armrest

To access the vertical position, raise the armrest until it locks.

Lower the armrest to put it back in the position for use.

To remove the armrest, press the release button from the vertical position and move aside the armrest.

To put the armrest back in place, clip it in the vertical position.

If the vehicle is fitted with the additional console and an armrest, to fold the passenger seat to the table position remove the console or the armrest.

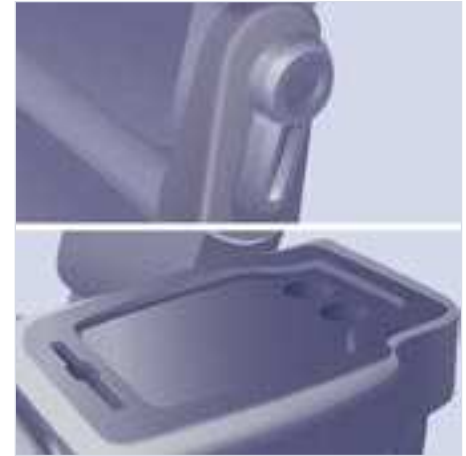

PASSENGER SEAT

The back of the individual passenger seat can be folded to form a writing table.

This position also permits the transportation of long loads.

Folding the seat back

Pull the lever forwards then tilt the seat back.

Returning the seat back to its original position

Pull the lever forwards then raise the seat back until it locks.



EXTENSO CAB

Centre seat

This is fitted with a 3-point seat belt with the seat belt return fixed on the load retaining ladder behind the driver.



Mobile office position

Pull the tab located on the lower edge of the seat to lower the seat back incorporating a writing table equipped with a strap.

To return the seat back to the upright position, pull the tab and guide the seat back until it locks.

During the operations, take care not to trap the tab under the seat cushion.



Storage compartment under the seat cushion

Raise the centre seat cushion to gain access to the storage compartment. This space can be made secure by fitting a padlock (not supplied).

 Before locking the seat in the sitting position, always take care to leave the seat belt buckles visible and the associated straps available for the passengers.



Side seat

The back of the side seat is fitted with a metal shell.

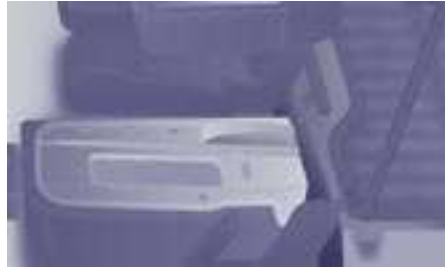

Retracted position

Pull the tab located on the upper edge of the seat by the head restraint to tilt and guide the entire seat.

It inserts itself into the floor in the front seat position and so forms a continuous flat floor with the load space.

This position permits the transportation of long loads inside the vehicle, up to 3 m (3.25 m in the case of the long versions) with the doors closed.

In the retracted position, the maximum weight on the seat back is 50 Kg.

To return the seat to the sitting position, raise the seat back until it locks on the floor in the seat position.



Foldaway position

Raise the yellow lever located at the base of the seat to release and raise the entire seat to the foldaway position (seat cushion raised against the seat back) until it locks.

This position permits the transportation of high loads in the cab part.

To return the seat to the sitting position, push the yellow lever located under the seat cushion and lower the entire seat until it is upright and locked on the floor in the seat position.

CONFIGURATIONS

Examples of various layouts combining comfort and practicality

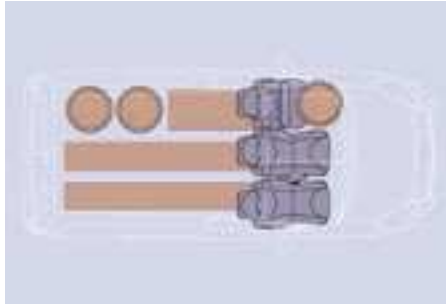
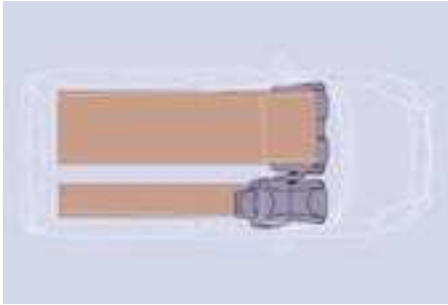
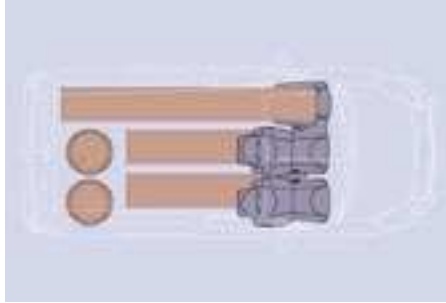
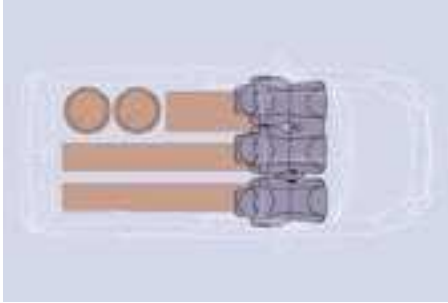

The various operations must be carried out while stationary.

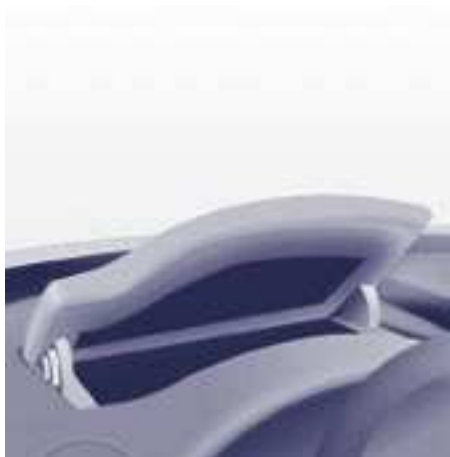

FRONT LAYOUT

Upper storage compartment

This is located on the fascia, behind the steering wheel.

A recess makes lifting of the lid easier when opening. Guide it to its rest position.

To close, guide the lid then press the centre gently.

Any liquid which could spill risks causing an electrical short circuit and therefore a potential fire.

1. Lower glove box

An auxiliary socket is located in the glove box (cable not supplied) for the connection of portable equipment (MP3 player, ...).

2. Storage tray and bottle holder (1.5 L)

3. Side storage compartment

4. Bag hook

Only hang flexible bags which are not too heavy on this hook.

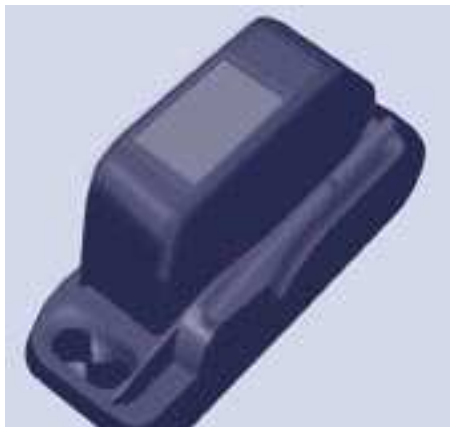

Central storage console

This console offers an appreciable additional storage area: it can be removed and clips onto a base which also incorporates two cup holders at the rear.

Ensure that the object (bottle, can...) placed in the cup holder is retained securely and does not risk being dislodged while driving.

Any liquid which could spill presents a risk of damage on contact with the instrument panel and centre console controls.

Take care.



Overhead storage unit

This is located above the sun visors and can accommodate various objects (a jumper, file, gloves...).

The openings concealed by the sun visors allow you to see and access the objects stored in the overhead storage unit.

The maximum weight permitted in the overhead storage unit is 5 Kg.

Do not place objects in this storage unit which could present a risk to the occupants.

Sun visor

To prevent dazzle from ahead, fold the sun visor down.

A pocket is provided in the driver's sun visor for storing toll cards, tickets, ...



Storage compartments under seats

Storage compartments may be provided in the floor under the front seats.

The tool kit and the jack are stored under the right-hand seat. Move the seat forward for easier access to the storage compartment.



Front courtesy light



Rear courtesy light



Front individual reading lights

COURTESY LIGHTS

Automatic switching on/off

The front courtesy light comes on when the key is removed from the ignition, when the vehicle is unlocked, when one of the front doors is opened and for location of the vehicle using the remote control.

It switches off gradually after the ignition is switched on and when the vehicle is locked.



Cab: comes on when one of the front doors is opened.



Load space: comes on when one of the rear doors is opened.

If the doors remain open for a few minutes, the courtesy lights are switched off.



These are switched on and off by means of a manual switch, with the ignition on.



Permanently on, ignition on.



Permanently off.



TORCH

A removable torch, incorporated in the wall of the boot, carries out two functions:

- boot light,
- torch.

The boot light operates automatically when the boot is opened.

The torch operates with NiMH type storage batteries.

Observe the polarities when fitting these storage batteries.

Using the torch

Remove it from its location by pulling from the top.

Press the switch, located on the back of the torch, to switch it on or off.

The retaining clip allows you to position the torch for precise use (for example, lighting while changing a wheel).

Storing the torch

Always put the torch back starting by positioning the lower part in its location. If it is not engaged correctly it may not charge and may not come on when the boot is opened.

Putting the torch back in place switches it off automatically if it has not been switched off already.

The torch has a maximum operating time of 45 minutes and charges within a few hours while driving.

Never replace the storage batteries with conventional batteries.



CREW CAB

Bench seat

The crew cab consists of a 3-seat bench, located in row 2, the one-piece back of which is solid with the "load retainer" grille.

Access to the rear seats is via the sliding side door.

Head restraints and seat belts

The three seats are equipped with inertia reel seat belts. The seat belts of the side seats are solid with the panels, whereas the seat belt of the centre seat is solid with the back of the bench seat.

Each seat has a head restraint bolted onto the load retaining grille and which can be removed.

Do not store a head restraint inside the vehicle unless it is stowed or fixed to a support.

Do not drive with rear passengers without first bolting the head restraints in place.



Placing the bench seat in the fully folded position

- If necessary, move the front seats forward and fasten the strap of the seat belt of the centre seat.
- Check that the seat belt straps and buckles are positioned correctly along the side panels, to ensure that the sliding of the seat back is not hindered.
- Release the seat back using the control **A**.



- Using the same hand, fold the seat back and the associated grille onto the seat cushion.



- Take hold of the red strap (like a handle) and lift the assembly vertically, guiding the movement to the fully folded position.

The raised seat rests against the backs of the seats of row 1.



Putting the bench seat back in the seat position

- In a single movement: take hold of the red strap and pull the assembly horizontally towards the rear. Guide the movement until the feet of the bench seat lock on the floor.
- Raise the seat back. The control **A** locks automatically.
- Check that the bench is locked on the floor correctly once it has been returned to the seat position.

Do not let the assembly fall sharply.

Good practice

There is no need to assist, guide or support using the arm which remains free during the tilting movement.

The rear seat belt casings are not designed for securing the load transported. Use the stowing rings on the floor only.

The bench seat of the crew cab is not suitable for the installation of a child seat.



LOAD SPACE LAYOUT

12 volt socket

Associated with the torch, it is advisable to limit its use to avoid discharging the battery. Maximum power: 120 W.



Stowing rings

Use the stowing rings on the rear floor to secure your loads.

As a safety precaution in case of sharp braking, you are advised to immobilise the load by securing it firmly using the stowing rings and place heavy objects as far forwards as possible (towards the cab).



Trims

The lower parts of the sides are fitted with load protection trims.



Ladder

Load retainers

Your vehicle can be equipped with a wide range of load retainers to effectively protect the driver and front passenger(s), while maintaining the loading adaptability.



Mid-height partition

Contact a CITROËN dealer for information about the different accessory load retainer models.



Partition with flap

Removable flap

The flap located on the panel section of the mid-height partition, behind the passenger seat(s), can be removed to permit the loading of long objects.

- Turn the control located at the top of the flap to release it.
- Lift the flap to remove it from its location.
- Pivot the flap by 90° to the right.
- Store it behind the driver's seat, clipping it into the securing lugs.



LOAD SPACE LAYOUT

12 volt socket

Associated with the torch, it is advisable to limit its use to avoid discharging the battery. Maximum power: 120 W.



Stowing rings

Use the stowing rings on the rear floor to secure your loads.

As a safety precaution in case of sharp braking, you are advised to immobilise the load by securing it firmly using the stowing rings and place heavy objects as far forwards as possible (towards the cab).



Trims

The lower parts of the sides are fitted with load protection trims.

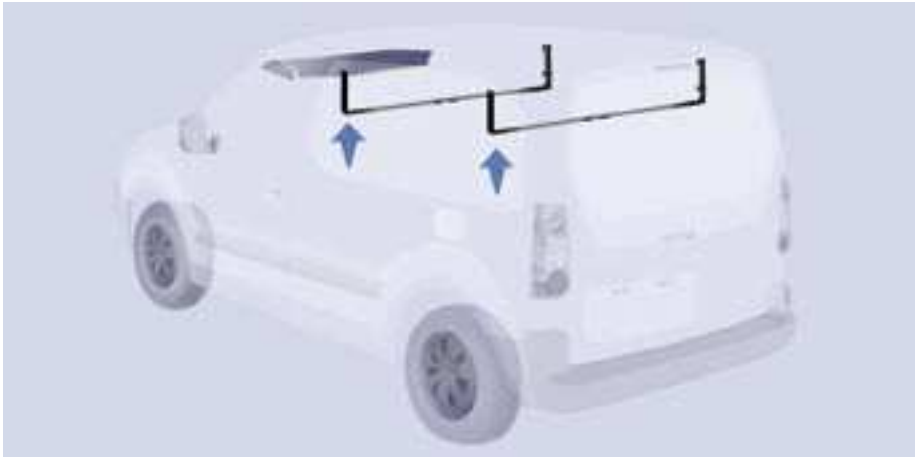

INTERIOR RACK

The interior rack consists of two bars to be installed at the top of the space leaving the lower area of the passenger compartment free.

It permits the transportation of long loads (2 metres maximum) with the doors or tailgate closed. The long load must rest on the overhead storage compartment and the two bars.

The two interior bars are covered with rubber and incorporate a strap passage to secure the loaded objects.

However, be sure to comply with the loads and weights permitted. Maximum load: 10 kilogrammes per bar.



Fitting the bars

- Unscrew the knurled wheels located at the ends of the bars fully.
- Take hold of the bar by the ends to slide them towards the inside to retract them.
- Extract the metal end piece **A** taking hold of the end of the bar like a syringe.
- Insert the end piece **A** on one side then lower it to fix it in the base of the notch **B**.
- Carry out the same operations on the other side.
- Ensure that they are engaged correctly at the base of the notch.
- Tighten the knurled wheels and check the tightening by pushing the bar sideways.

To remove, proceed in the reverse order.

Storing

When the bars are not in use:

- partially loosen the knurled wheels,
- lift the bar slightly,
- pivot it upwards by 180°,
- tighten the knurled wheels.

Good practice

In the event of a front impact, the rack is disengaged to avoid injury to the occupants of the vehicle. The slight clearance observed in the bar is linked with this safety disengagement.

Do not loosen or place the bars in a position other than those described above.

The load on the rack must rest on the overhead storage compartment and be strapped using the strap passages provided on the bars.

The bars are not grab handles for the passengers.

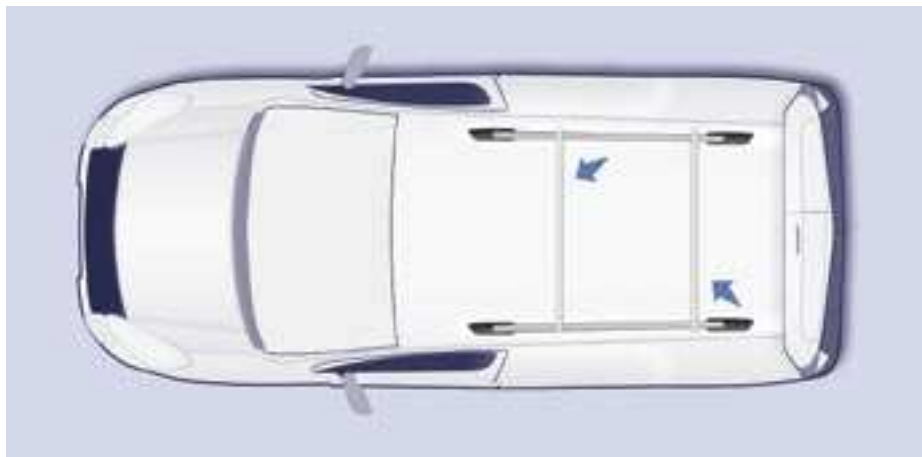

ROOF BARS

If you install transverse bars on these bars, refer to the weight values indicated by the manufacturer but do not exceed 75 Kg.



MIRRORS

Manual exterior mirrors

Move the lever in all four directions to adjust.

When the vehicle is parked, the exterior mirrors can be folded back manually.

The mirrors are not equipped with automatic de-icing.



Electric exterior mirrors

- Move the control to the right or to the left to select the corresponding mirror.
- Move the control in all four directions to adjust.
- Return the control to the central position.



Electric folding/unfolding

The mirrors can be folded or unfolded electrically from the inside, with the vehicle parked and the ignition on:

- Place the control in the central position.
- Turn the control downwards.

Heated mirrors



The electric mirrors can be heated. Press the rear screen de-icing button.



Forced folding

If the mirror casing has come out of its initial location, with the vehicle stationary reposition the mirror casing manually or use the electric folding control.



Areas for toll cards/car park tickets

The athermic windscreen has two non-reflective zones located either side of the base of the interior mirror.

They are intended for affixing toll cards and/or car park tickets.

Manual interior mirror

The interior mirror has two positions:

- day (normal),
- night (anti-dazzle).

To change from one to the other, push or pull the lever on the lower edge of the mirror.



ELECTRIC WINDOWS

1. Driver's electric window control
 2. Passenger electric window control
- There are two operating modes:

Manual mode

Press or pull the control, without passing the point of resistance. The window stops when you release the control.

Automatic mode

Press or pull the control, beyond the point of resistance. The window opens or closes fully when the control is released. Pressing the control again stops the movement of the window.

The electrical functions of the electric windows are deactivated:

- approximately 45 seconds after the ignition is switched off,
- after one of the front doors is opened, if the ignition is off.

Safety auto-reverse

When the window rises and meets an obstacle, it stops and partially lowers.

Reinitialisation

Following reconnection of the battery, or in the event of a malfunction, the safety auto-reverse function must be reinitialised.

Lower the window fully, then raise it, it will rise in steps of a few centimetres each time the control is pressed. Repeat the operation until the window is fully closed.

Continue to press the control for at least one second after the window closed position has been reached.

The safety auto-reverse does not operate during these operations.

Good practice

If the electric windows meet an obstacle during operation, you must reverse the movement of the window. To do this, press the control concerned.

When the driver operates the passenger electric window controls, he must ensure that no one is preventing correct closing of the windows.

The driver must ensure that the passengers use the electric windows correctly.

Be aware of children when operating the windows.

Following several consecutive closing/opening operations of the electric window control, a protection system is triggered which only authorises closing of the window. After closing, wait approximately 40 minutes. Once this time has elapsed, the control becomes operational again.

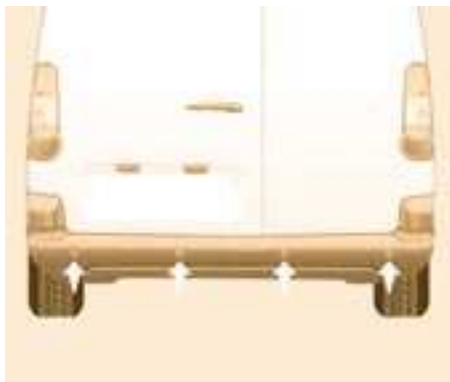

REAR PARKING ASSISTANCE

The audible and/or visual rear parking assistance consists of four proximity sensors, installed in the rear bumper. The sensors detect any obstacle which enters the field: person, vehicle, tree, fence, behind the vehicle during the manoeuvre.

Certain objects detected at the beginning of the manoeuvre will no longer be detected at the end of the manoeuvre due to the blind spots between and below the sensors. Examples: stake, roadworks cone or pavement post.

Engage reverse gear

An audible signal confirms the activation of the system by engaging reverse gear. The proximity information is indicated by an audible signal which becomes more rapid as the vehicle approaches the obstacle.

When the distance between the rear of the vehicle and the obstacle is less than approximately thirty centimetres, the audible signal becomes continuous.



Display on the screen

Stop the assistance

Change to neutral.



Activation/Deactivation



You can activate or deactivate the system by pressing this button.

The activation or deactivation of the system is stored when the vehicle stops.

Operating fault

In the event of an operating fault, when reverse gear is engaged the diode on the button comes on, accompanied by an audible signal and a message on the display. Consult a CITROËN dealer.

Good practice

In bad weather or in winter, ensure that the sensors are not covered with mud, ice or snow.

The system will be deactivated automatically if a trailer is being towed or if a bicycle carrier is fitted (vehicle fitted with a towbar or bicycle carrier recommended by CITROËN).

The parking assistance cannot, in any circumstances, take the place of the vigilance and responsibility of the driver.

i You are advised to deactivate the system if your vehicle is fitted with a rear ladder or if you are transporting a load which exceeds the length of the vehicle.

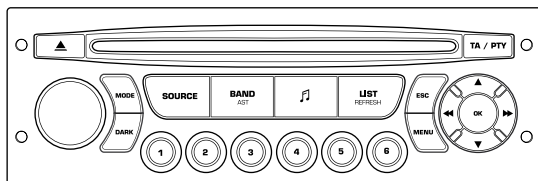

AUDIO EQUIPMENT

MP3/HANDS-FREE KIT



The audio equipment is coded in such a way that it will only operate in your vehicle. If it is to be installed in another vehicle, contact a CITROËN dealer for configuration of the system.

CONTENTS

- **01 First steps** pg. 79
- **02 Displays and menus** pg. 80
- **03 Audio** pg. 82
- **04 Hands-free kit** pg. 85
- **05 Trip computer** pg. 87
- **06 Control short-cuts** pg. 88
- **07 Configuration** pg. 89
- **08 Display flow charts** pg. 91



For safety reasons, the driver must carry out operations which require prolonged attention while the vehicle is stationary. When the engine is off, and in order to prevent discharging of the battery, the audio equipment may switch off after a few minutes.

FIRST STEPS 01

CD eject.

 On - Off.
Volume dial.

Mode: Selection of the screen display mode.
Dark: Hide the screen display, until completely black, by successive presses. Pressing again reactivates the display.

BAND - AST: Storing of the 6 strongest transmitters received on FM.





Source: Selection of the source; radio, CD and CD changer.

Band: Selection of the FM1, FM2, FMast and AM wavebands.

 : Setting the audio options:
Front/rear balance, left/right balance,
loudness, sound ambiances.

List: Displaying of the local stations, of the tracks on the CD or of the MP3 directories.

- Storing of a station.
 - Selection of a stored radio station.
 - Selection of a CD in the CD changer.
-  updating of the stations received.

 A long press is required.

 Navigator which selects the choices above or the step by step or rapid advances. Pressing the navigation dial confirms the choice, but does not store it.

ESC: Abandon current operation.
Menu: Displaying of the general menu.



For a detailed global view of the menus available, refer to the "Display flow chart" section of this chapter.

02 DISPLAY AND MENU A

> DISPLAY A



This displays the following information, via the audio equipment control pad:

- the time,
- the date,
- the exterior temperature (this flashes if there is a risk of ice),
- the audio source displays (radio, CD, ...),
- the accesses check (doors, boot, ...),
- the warning messages or information messages displayed temporarily, can be cleared by pressing the "ESC" button,
- the trip computer,

> GENERAL MENU

Press the MENU button then OK.



RADIO: RDS search, REG mode. CD: introscan, random play, repeat.

VEHICLE CONFIGURATION: activation/deactivation of the equipment.

OPTIONS: equipment status diagnostics.

DISPLAY ADJUST: year, month, day, hour, minute, 12 or 24 hour mode.

LANGUAGES.

UNITS: temperature (°C or °F), fuel consumption (l/100, mpg or km/l).

DISPLAY AND MENU C 02

> DISPLAY C



This displays the following information, via the audio equipment control pad:

- the time,
- the date,
- the exterior temperature (this flashes if there is a risk of ice),
- the audio source displays (radio, CD, ...),
- the accesses check (doors, boot, ...),
- the warning messages (e.g.: "Antipollution fault") or information messages (e.g.: "Auto lighting activated") displayed temporarily, can be cleared by pressing the "ESC" button,
- the trip computer,
- the location of a faulty wheel,
- the detection of a rear obstacle.

> GENERAL MENU

AUDIO FUNCTION:
radio, CD, options.

PERSONALISATION-
CONFIGURATION:
vehicle parameters,
display, languages.



TRIP COMPUTER: distance
entering, warnings, status of
functions.

TELEPHONE:
hands-free
kit, matching,
management of a
call.

03 AUDIO





The external environment (hills, buildings, tunnels, basement car parks) may block reception, including in RDS mode. This is a normal effect of the way in which radio waves are transmitted and does not indicate any failure of the audio equipment.

RADIO SELECTING A STATION

1  Press the SOURCE button several times in succession and select the radio.



2  Press the BAND AST button to select a waveband: FM1, FM2, FMast, AM.



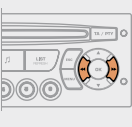

3  Briefly press one of the buttons to carry out an automatic search of the radio stations.

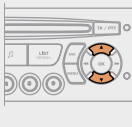

4  Press one of the buttons to carry out a manual search of the radio stations.



  Press the LIST REFRESH button to display the list of stations received locally (30 stations maximum). To update this list, press for more than two seconds.

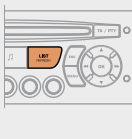



RDS

1  Press the MENU button.





2  Select AUDIO FUNCTIONS then press OK.

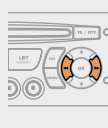

3  Select the FM WAVEBAND PREFERENCES function then press OK.

FM WAVEBAND PREFERENCES **OK**



4  Select ACTIVATE FREQUENCY FOLLOWING (RDS) then press OK. RDS appears on the display.

ACTIVATE FREQUENCY FOLLOWING (RDS) **OK**



! The RDS, if displayed, enables you to continue listening to the same station by means of frequency following. However, in certain conditions, this RDS station is not followed throughout the country as radio stations do not cover 100 % of the territory. This explains the loss of reception of the station during a journey.

CD PLAYING A CD



Insert circular compact discs only. Some anti-pirating systems, on original discs or CDs copied using a personal recorder, may cause faults which are no reflection on the quality of the original player. Without pressing the EJECT button, insert a CD in the player, play begins automatically.

1



To play a disc which has already been inserted, press the SOURCE button several times in succession and select CD.

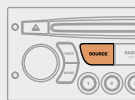

2



Press one of the buttons to select a track on the CD. Press the LIST REFRESH button to display the list of tracks on the CD.

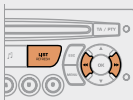

MP3 CD INFORMATION AND ADVICE



The MP3 format, an abbreviation of MPEG 1.2 & 2.5 Audio Layer 3, is an audio compression standard which permits the recording of several tens of music files on a single disc. The playing and displaying of an MP3 compilation may depend on the recording programme and/or the parameters used.



In order to be able to play a recorded CDR or CDRW, when recording select standards ISO 9660 level 1.2 or Joliet. If the disc is recorded in another format, it may not be played correctly. It is recommended that the same recording standard is always used for an individual disc, with as low a speed as possible for optimum sound quality. In the particular case of a multi-session CD, the Joliet standard is recommended.



The audio equipment will only play files with the extension ".mp3". No other type of file (.wma, .mp4...) can be played.



It is advisable to restrict file names to 20 characters without using special characters (e.g.: " " ? ; ù) to avoid any playing or displaying problems.

CD PLAYING AN MP3 COMPILATION*



Insert an MP3 compilation in the player. The audio equipment searches for all of the music tracks, which may take anything between a few seconds and several tens of seconds, before play begins.



On a single disc, the CD player can read up to 255 MP3 files spread over 8 directory levels. However, it is advisable to keep to a limit of two levels to reduce the access time before the CD is played.

1



To play a disc which has already been inserted, press the SOURCE button several times in succession and select CD.

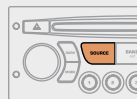

2



Press one of the buttons to select a track on the CD. Press the LIST REFRESH button to display the list of directories of the MP3 compilation.

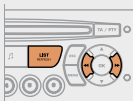

* According to level of finish.

CD CHANGER - not MP3 compatible Playing a CD

1



Insert the CDs in the changer one by one. Press the SOURCE button several times in succession and select CD CHANGER.

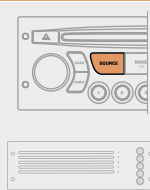

2



Press one of the buttons on the numeric keypad to select the corresponding CD. Press and hold one of the CD changer buttons to eject the corresponding CD.

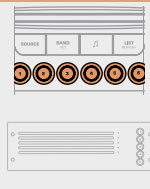

3



Press one of the buttons to select a track on the CD. Press and hold one of the buttons for fast forwards or backwards play.



04 HANDS-FREE KIT



MATCHING A TELEPHONE DISPLAY C



For safety reasons and because they require prolonged attention on the part of the driver, the operations for matching of the Bluetooth mobile telephone with the audio equipment hands-free kit must be carried out with the vehicle stationary and the ignition on.

- 1 Activate the telephone's Bluetooth function and carry out a search of the Bluetooth accessories present for the telephone.



- 2 Select the accessory which corresponds to the name of the vehicle, a superimposed configuration display appears on the multifunction display.



- 3 Enter the vehicle's authentication code (=1234). Depending on the telephone, you may be asked to enter this code before the superimposed configuration display appears.



- 5 Select the YES tab on the display using the buttons then confirm by pressing OK.



YES

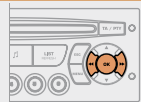

The services offered by the hands-free kit depend on the network, the SIM card and the compatibility of the Bluetooth equipment used.

Consult your telephone's manual and your operator to find out which services are available to you. A list of mobile telephones which offer the best range of services is available from the network. Consult a CITROËN dealer.

Refer to the end of the "Correct use of the hands-free kit telephone" section.

RECEIVING A CALL

- 1 An incoming call is announced by a ring and a superimposed display on the multifunction display.

2



Select the YES tab on the display using the buttons and confirm by pressing OK.

YES

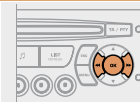

Press the end of the steering wheel stalk to accept the call.



MAKING A CALL



Press the end of the steering wheel stalk for more than two seconds to access your directory.

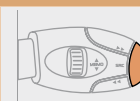

1

To dial a number, use the keypad on your telephone.



Correct use of the hands-free kit telephone

The matching of a new Bluetooth mobile telephone does not work while the vehicle is being driven.

For safety reasons and because they require prolonged attention on the part of the driver, the operations for matching the Bluetooth mobile telephone with the audio equipment hands-free kit must be carried out with the vehicle stationary and the ignition on.

How many mobile telephones can be stored in the audio equipment.

Up to 4 different mobile telephones can be stored. The mobile telephone stored as 1 will be connected first, then number 2, ...

Is it possible to scroll through the phone book contacts more quickly than line by line.

The controls << >> on the control panel or on the steering wheel control permit direct access to the first contact recorded starting with the next/previous letter of the alphabet.

Are all of the numbers associated with a contact displayed on the audio equipment display.

A maximum of 4 different numbers for one contact in Vcard format are displayed: "Home", "Work", "Mobile" and "Car".

05 TRIP COMPUTER

VEHICLE DIAGNOSTICS



Each press of the button, located at the end of the wipers stalk, permits displaying of the different trip computer data in succession, depending on the display.

DISPLAY A



Each press displays in succession:

- Range,
- Current consumption
- Distance travelled,
- Average consumption,
- Average speed.

DISPLAY C



- the "vehicle" tab with:
 - the range, the current consumption and the distance remaining to the destination,
- the "1" tab (route 1) with:
 - the average speed, the average consumption and the distance travelled calculated over route "1",
- the "2" tab (route 2) with the same characteristics for a second route.



Zero reset

When the required route is displayed, press the control for more than two seconds.

A few definitions

Range: Displays the distance which can be travelled with the remaining fuel detected in the tank, in relation to the average consumption over the last few miles (kilometres).

This displayed value may vary significantly following a change in the vehicle speed or the relief of the route.

When the range falls below 20 miles (30 km), dashes are displayed. After filling with at least 5 litres of fuel, the range is recalculated and is displayed when it exceeds 60 miles (100 km).

If, whilst driving, dashes are displayed continuously in place of digits, contact a CITROËN dealer.

Current consumption: only calculated and displayed above 20 mph (30 km/h).

Average consumption: this is the average quantity of fuel consumed since the last trip recorder zero reset.

Distance travelled: calculated since the last trip computer zero reset.

Distance remaining to the destination: calculated with reference to the final destination, entered by the user. If guidance is activated, the navigation system calculates it as a current value.

Average speed: this is the average speed calculated since the last trip computer zero reset (ignition on).

06 CONTROL SHORT-CUTS

STEERING WHEEL CONTROLS

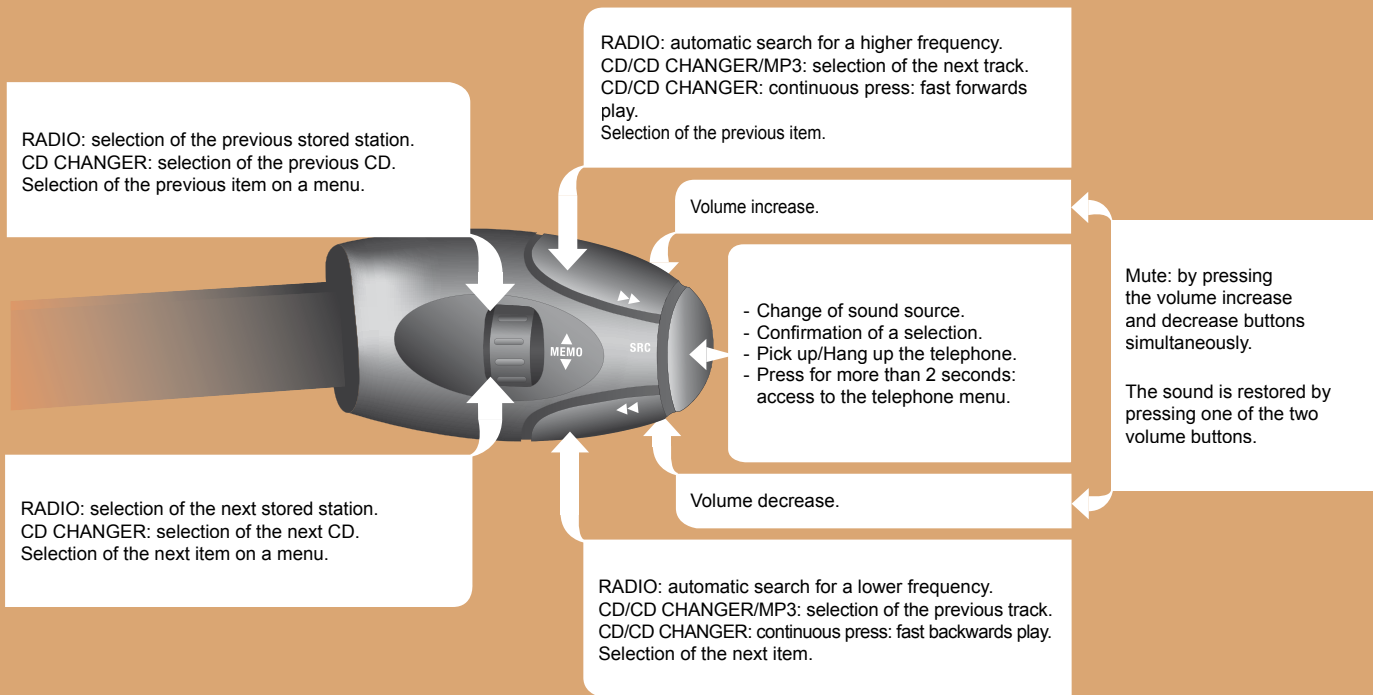

07 CONFIGURATION



ADJUSTING THE DATE AND TIME DISPLAY A



The time-display sequence is linked to the model (version). The access to the Date is only active when the model version offers a date in words.

1



Press the MENU button.

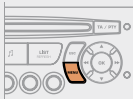

2



Using the arrows, select the DISPLAY SETTINGS function.

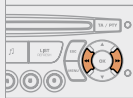

DISPLAY SETTINGS.

3



Press to confirm the selection.

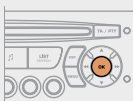

4



Using the arrows, select one of these functions: YEAR/MONTH/DAY/ HOURS/MINUTES/12 OR 24.

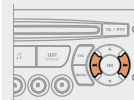

5



Press to confirm the selection.

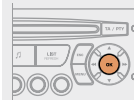

6



Adjust the parameters one by one confirming by pressing the OK button. Next select the OK tab on the display then confirm.

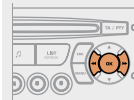

OK

07 CONFIGURATION



ADJUSTING THE DATE AND TIME DISPLAY C

1



Press the MENU button.

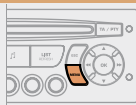

2



Using the arrows, select the PERSONALISATION CONFIGURATION function.



PERSONALISATION CONFIGURATION

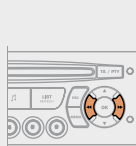

3



Press to confirm the selection.



4



Using the arrows, select the DISPLAY CONFIGURATION function.

DISPLAY CONFIGURATION

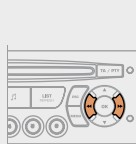

5



Press to confirm the selection.



6



Using the arrows, select the ADJUST DATE AND TIME function.

ADJUST DATE AND TIME



7



Press to confirm the selection.



8

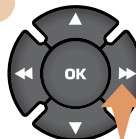

Adjust the parameters one by one confirming by pressing the OK button. Next select the OK tab on the display then confirm.

OK

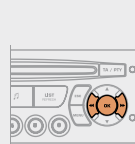

08 DISPLAY FLOW CHART monochrome A

A



- 1 MAIN FUNCTION
- 2 CHOICE A
- 3 Choice A1
- 3 Choice A2
- 2 CHOICE B...

1 RADIO-CD

2 RDS SEARCH

- 3 active
- 3 inactive

2 REG MODE

- 3 active
- 3 inactive

2 INTROSCAN

- 3 active
- 3 inactive

2 CD REPEAT

- 3 active
- 3 inactive

2 RANDOM PLAY

- 3 active
- 3 inactive

1 VEHICLE CONFIG*

2 REV WIPE ACT

- 3 active
- 3 inactive

2 AUTO LIGHTS

- 3 active
- 3 inactive

2 GUIDE LAMPS

- 3 active
- 3 inactive

2 PARKING ASSIST

- 3 active
- 3 inactive

1 OPTIONS

2 ABANDON/CONSULT LIST OF FAULTS

- 3 functions activated (or not)
- 3 warning messages

1 DISPLAY ADJUST

2 YEAR

2 MONTH

2 DAY

2 HOUR

2 MINUTES

2 12 H/24 H MODE

1 LANGUAGES

2 FRANCAIS

2 ITALIANO

2 NEDERLANDS

2 PORTUGUES

2 PORTUGUES-BRASIL

2 DEUTSCH

2 ENGLISH

2 ESPANOL

1 UNITS

2 TEMPERATURE: °CELSIUS/°FAHRENHEIT

2 FUEL CONSUMPTION: KML - L/100 - MPG

* The parameters vary according to vehicle.

08 DISPLAY C FLOW CHART



1 AUDIO FUNCTIONS

2 FM BAND PREFERENCES

3 alternative frequencies (RDS)

4 activate/deactivate

3 regional mode (REG)

4 activate/deactivate

3 radio-text information (RDTXT)

4 activate/deactivate

2 AUDIO CD PREFERENCES

3 CD changer repeat (RPT)

4 activate/deactivate

3 track random play (RDM)

4 activate/deactivate



1 TRIP COMPUTER

2 ENTER DISTANCE TO DESTINATION

3 distance: x km

2 WARNING LOG

3 diagnostics

2 STATUS OF FUNCTIONS*

3 functions activated or deactivated



1 PERSONALISATION-CONFIGURATION

2 DEFINE THE VEHICLE PARAMETERS*

2 DISPLAY CONFIGURATION

3 video brightness adjustment

4 normal video

4 inverse video

4 brightness (- +) adjustment

3 date and time adjustment

4 day/month/year adjustment

4 hour/minute adjustment

4 choice of 12 h/24 h mode

3 choice of units

4 l/100 km - mpg - km/l

4 °Celsius/°Fahrenheit

2 CHOICE OF LANGUAGE

* The parameters vary according to vehicle.

** According to compatibility of Bluetooth telephone and service contract.



1 TELEPHONE

2 CONSULTING DIRECTORIES**

3 telephone directory

3 call log

3 services directory

4 customer contact centre

4 breakdown call

4 emergency call

2 CONFIGURATION

3 deletion of a match

4 list of matches

3 consulting matches

4 list of matches

3 choice of a mobile to connect

4 list of mobiles

2 MANAGEMENT OF A COMMUNICATION

3 switch**

3 terminate the current call

3 secret mode

4 activate/deactivate



CD CHANGER - not MP3 compatible

Playing a CD

Insert the CDs in the changer one by one.

Press the SOURCE button several times in succession and select CD CHANGER.

Press one of the buttons on the numeric keypad to select the corresponding CD.

Press and hold one of the CD changer buttons to eject the corresponding CD.



Press one of the buttons to select a track on the CD.

Press and hold one of the buttons for fast forwards or backwards play.



Using the auxiliary input (AUX) Jack/RCA cable not supplied

The auxiliary input permits the connection of portable equipment (MP3 player, ...). It is activated by default.

Connect the portable equipment (MP3 player, ...) to the audio sockets (white and red RCA type) located in the glove box using a JACK/RCA audio cable.

Press the SOURCE button several times in succession and select AUX.

DRIVING SAFETY



HAZARD WARNING LIGHTS

Press this button, the direction indicators flash.

They can operate with the ignition off.

The hazard warning lights should only be used in dangerous situations, when stopping in an emergency or when driving in unusual conditions.

Automatic lighting of hazard warning lights

When braking in an emergency, depending on the force of deceleration, the hazard warning lights come on automatically. They switch off automatically the first time you accelerate.

It is also possible to switch them off by pressing the button on the fascia.

HORN

Press the centre of the steering wheel.



HANDBRAKE

Applying

Pull the handbrake to immobilise your vehicle.

Check that the handbrake is applied firmly before leaving the vehicle.



If the handbrake is still on or has not been released properly, this is indicated by this warning light which comes on on the instrument panel.

When parking on a slope, direct your wheels towards the pavement and pull the handbrake.

There is no advantage in engaging a gear after parking the vehicle, particularly if the vehicle is loaded.

Releasing

Pull the handle and press the button to lower the handbrake.

ANTI-LOCK BRAKING SYSTEM (ABS - EBFD)

The ABS and EBFD (electronic brake force distribution) systems improve the stability and manoeuvrability of your vehicle on braking, in particular on poor or slippery surfaces.

The ABS prevents locking of the wheels, the EBFD provides control of the braking pressure wheel by wheel.

Good practice

The anti-lock braking system comes into operation automatically when there is a risk of wheel lock. It does not reduce the braking distance.

On very slippery surfaces (ice, oil, etc...) the ABS may increase the braking distance. When braking in an emergency, do not hesitate to press the brake pedal firmly, without releasing the pressure, even on a slippery surface, you will then be able to continue to manoeuvre the vehicle to avoid an obstacle.

Normal operation of the ABS may be felt by slight vibration of the brake pedal.

When changing wheels (tyres and rims), ensure that these are recommended by CITROËN.



If this warning light comes on, accompanied by an audible signal and a message on the display, it indicates a malfunction of the ABS which could result in a loss of control of the vehicle on braking.



If this warning light comes on, together with the brake and STOP warning lights, accompanied by an audible signal and a message on the display, it indicates a malfunction of the electronic brake force distribution which could result in a loss of control of the vehicle on braking.

Stop immediately.

In both cases, contact a CITROËN dealer.

EMERGENCY BRAKING ASSISTANCE SYSTEM (EBA)

In an emergency, this system enables the optimum braking pressure to be reached more quickly, press the pedal firmly without releasing it.

It is triggered by the speed at which the brake pedal is activated.

This alters the resistance of the brake pedal under your foot.

To prolong the operation of the emergency braking assistance system: keep your foot on the brake pedal.



TRACTION CONTROL (ASR) AND DYNAMIC STABILITY CONTROL (ESP)

These systems are linked and complement the ABS.

The ASR system is very useful for maintaining optimum drive and avoiding losses of control of the vehicle on acceleration.

The system optimises drive to prevent the wheels skidding, by acting on the brakes of the drive wheels and on the engine. It also allows the directional stability of the vehicle to be improved on acceleration.

Use the ESP to hold your course without attempting to countersteer.

If there is a variation between the trajectory followed by the vehicle and that required by the driver, the ESP system automatically acts on the engine and the brake of one or more wheels, in order to put the vehicle back on course.

Operation of the ASR and ESP systems



The luminous diode flashes when the ASR or ESP is triggered.

Disarming the ASR/ESP systems

In certain exceptional conditions (starting the vehicle when stuck in mud or snow, or on loose ground...), it could prove useful to disarm the ASR and ESP systems to make the wheels spin and regain grip.

- Press the button, located on the centre console.
- The indicator light comes on: the ASR and ESP systems no longer act.

They engage again:

- automatically above 30 mph (50 km/h),
- manually by pressing the button again.

Operating check



When a malfunction of the systems occurs, the indicator light comes on, accompanied by an audible signal and a message on the display.

Contact a CITROËN dealer to have the system checked.

The warning light may also come on if the tyres are under-inflated. Check the pressure of each tyre.

Good practice

The ASR/ESP systems offer increased safety during normal driving, but should not incite the driver to take risks or to drive at high speed.

The operation of these systems is ensured if the recommendations of the manufacturer regarding the wheels (tyres and rims), the braking components, the electronic components and the fitting and repair procedures within the CITROËN network are observed.

After an impact, have these systems checked by a CITROËN dealer.



SEAT BELTS

Height adjustment

Squeeze the control with the return and slide the assembly on the driver's seat side and on the individual passenger seat side.

The height of the seat belt associated with the centre seat of the front bench cannot be adjusted.

Fastening

Pull the strap, then insert the tongue into the buckle.

Check that the seat belt is fastened correctly by pulling the strap.



Unfastening

Press the red button.

Driver's seat belt not fastened warning light



When the vehicle is started, this warning light comes on if the driver has not fastened his seat belt.

Good practice

Wherever you are seated in the vehicle, always fasten your seat belt, even for short journeys.

The seat belts are fitted with an inertia reel which automatically adjusts the length of the strap to your size. The seat belt is rolled up automatically when not in use.

Ensure that the seat belt is rolled up correctly after use.

Depending on the nature and seriousness of any impact, the pretensioning device may be triggered before and independently of inflation of the air bags. It instantly tightens the seat belts against the body of the occupants.

Triggering of the pretensioners is accompanied by a slight discharge of harmless smoke and a noise, due to the activation of the pyrotechnic cartridge incorporated in the system.

The force limiter reduces the pressure of the seat belt against the body of the occupants. The equipment fitted to these seat belts is operational when the ignition is switched on.

The inertia reels are fitted with a device which automatically locks the strap in the event of a collision or emergency braking. You can release the seat belt and allow the strap to roll up.

The air bag warning light comes on if the pretensioners are triggered. Consult a CITROËN dealer.

In order to be effective, a seat belt must:

- restrain one person only,
- must not be twisted, check by pulling in front of you with an even movement,
- be tightened as close to the body as possible.

The upper part of the seat belt should be positioned in the hollow of the shoulder.

The lap part should be placed as low as possible on the pelvis.

Do not invert the seat belt buckles as they will not fulfil their role completely. If the seats are fitted with armrests, the lap part of the seat belt should always pass under the armrest.

Check that the seat belt is fastened correctly by pulling the strap firmly.

Recommendations for children:

- use a suitable child seat if the passenger is less than 12 years old or shorter than one metre fifty,
- never allow a child to travel on your lap, even with the seat belt fastened.



For further information regarding child seats, refer to the "Children on board" section of chapter 5.

In accordance with current safety regulations, your CITROËN dealer guarantees all work or any checks, from testing to maintenance, on your seat belt equipment.

Have the seat belts checked regularly (even after a minor impact) by a CITROËN dealer: they must not show any signs of wear, cutting or fraying and they must not be transformed or modified.



Clean the seat belt straps with soapy water or a textile cleaning product, sold by CITROËN dealers.

Front seat belts

The front seats are fitted with pretensioners and force limiters. The seat belt associated with the centre seat of the front bench does not have a pretensioner.



AIR BAGS

The air bags have been designed to maximise the safety of the occupants in the event of a serious collision; they work in conjunction with the force limiting seat belts.

In the event of a serious collision, the electronic detectors record and analyse the front and side impacts suffered in the impact detection zones:

- in the event of a serious impact, the air bags inflate instantly and protect the occupants of the vehicle. Immediately after the impact, the air bags deflate rapidly, so that they do not hinder the visibility of the occupants nor their possible exit from the vehicle.

- in the event of a minor or rear impact and in certain roll-over conditions, the air bags will not be deployed; the seat belt alone is sufficient to provide maximum protection in these situations.

The seriousness of the collision depends on the nature of the obstacle and the speed of the vehicle at the moment of impact.

i Air bags only operate when the ignition is switched on.

This equipment only operates once. If a second impact occurs (during the same or a subsequent accident), the air bag will not operate.

The triggering of an air bag or air bags is accompanied by a slight discharge of harmless smoke and a noise, due to the activation of the pyrotechnic cartridge incorporated in the system.

This smoke is not harmful, but sensitive individuals may experience some irritation.

The noise of the detonation may result in a slight loss of hearing for a short time.



+ It is imperative that the passenger air bag is disarmed if a child seat is installed facing rearwards. Refer to the "Children on board" section of chapter 5.

Good practice

Sit in a normal upright position.

Wear a correctly adjusted seat belt.

Do not leave anything between the occupants and the air bags (a child, pet, object...). This could hamper the operation of the air bags or injure the occupants.

After an accident or if the vehicle has been stolen or broken into, have the air bag systems checked.

All work on the air bag system is strictly forbidden unless it is carried out by qualified personnel of the CITROËN network.

Even if all of the precautions mentioned are observed, a risk of injury or of minor burns to the head, chest or arms when an air bag is triggered cannot be ruled out. In fact, the bag inflates almost instantly (within a few milliseconds) then deflates within the same time discharging the hot gas via openings provided for this purpose.

Side air bags

Only put recommended covers on the seats. These will not hinder inflation of the side air bags. Consult a CITROËN dealer.

Do not fix or glue anything to the seat backs. This could cause injury to the chest or arms when the side air bag inflates.

Do not sit with the upper part of the body any nearer to the door than necessary.

Front air bags

Do not drive holding the steering wheel by its spokes or resting your hands on the centre part of the wheel.

Do not allow passengers to place their feet on the fascia, they risk serious injury if the air bag is triggered.

Smoke as little as possible as deployment of the air bags can cause burns or the risk of injury from a cigarette or pipe.

Never remove or pierce the steering wheel or hit it violently.

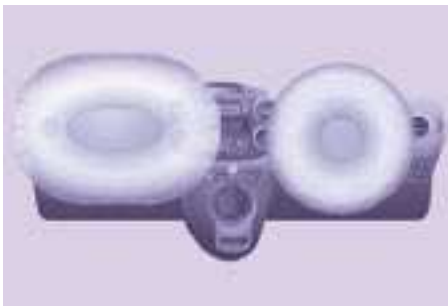

Front air bags

The front air bags are incorporated in the centre of the steering wheel for the driver and in the fascia for the front passenger(s).

Activation

They are deployed simultaneously, unless the passenger's front air bag has been disarmed, in the event of a serious front impact applied to all or part of the front impact zone **A** in the longitudinal centreline of the vehicle on a horizontal plane directed from the front towards the rear of the vehicle.

The front air bag inflates between the front occupant of the vehicle and the fascia to cushion his forward movement.



Disarming

The passenger's front air bag alone can be disarmed:

- **With the ignition switched off**, insert the key into the passenger air bag disarming switch
- turn it to the **"OFF"** position,
- then remove the key keeping the slot in this position.



The air bag warning light on the instrument panel is lit throughout the period of disarming.



To ensure the safety of your child, it is essential to disarm the passenger air bag when you install a rear-facing child seat on the front passenger seat. Otherwise, the child would risk being killed or seriously injured if the air bag were to inflate.

Reactivation

In the **"OFF"** position, the passenger air bag will not be triggered in the event of an impact.

As soon as the child seat is removed, turn the air bag slot to the **"ON"** position to re-activate the air bag and thus ensure the safety of your passenger in the event of an impact.

Front air bag fault



If this warning light comes on, accompanied by an audible signal and a message on the display, consult a CITROËN dealer to have the system checked.



If the two air bag warning lights are lit continuously, do not install a rear-facing child seat. Consult a CITROËN dealer.



AIR BAGS

The air bags have been designed to maximise the safety of the occupants in the event of a serious collision; they work in conjunction with the force limiting seat belts.

In the event of a serious collision, the electronic detectors record and analyse the front and side impacts suffered in the impact detection zones:

- in the event of a serious impact, the air bags inflate instantly and protect the occupants of the vehicle. Immediately after the impact, the air bags deflate rapidly, so that they do not hinder the visibility of the occupants nor their possible exit from the vehicle.

- in the event of a minor or rear impact and in certain roll-over conditions, the air bags will not be deployed; the seat belt alone is sufficient to provide maximum protection in these situations.

The seriousness of the collision depends on the nature of the obstacle and the speed of the vehicle at the moment of impact.

i Air bags only operate when the ignition is switched on.

This equipment only operates once. If a second impact occurs (during the same or a subsequent accident), the air bag will not operate.

The triggering of an air bag or air bags is accompanied by a slight discharge of harmless smoke and a noise, due to the activation of the pyrotechnic cartridge incorporated in the system.

This smoke is not harmful, but sensitive individuals may experience some irritation.

The noise of the detonation may result in a slight loss of hearing for a short time.



+ It is imperative that the passenger air bag is disarmed if a child seat is installed facing rearwards. Refer to the "Children on board" section of chapter 5.

Good practice

Sit in a normal upright position.

Wear a correctly adjusted seat belt.

Do not leave anything between the occupants and the air bags (a child, pet, object...). This could hamper the operation of the air bags or injure the occupants.

After an accident or if the vehicle has been stolen or broken into, have the air bag systems checked.

All work on the air bag system is strictly forbidden unless it is carried out by qualified personnel of the CITROËN network.

Even if all of the precautions mentioned are observed, a risk of injury or of minor burns to the head, chest or arms when an air bag is triggered cannot be ruled out. In fact, the bag inflates almost instantly (within a few milliseconds) then deflates within the same time discharging the hot gas via openings provided for this purpose.

Side air bags

Only put recommended covers on the seats. These will not hinder inflation of the side air bags. Consult a CITROËN dealer.

Do not fix or glue anything to the seat backs. This could cause injury to the chest or arms when the side air bag inflates.

Do not sit with the upper part of the body any nearer to the door than necessary.

Front air bags

Do not drive holding the steering wheel by its spokes or resting your hands on the centre part of the wheel.

Do not allow passengers to place their feet on the fascia, they risk serious injury if the air bag is triggered.

Smoke as little as possible as deployment of the air bags can cause burns or the risk of injury from a cigarette or pipe.

Never remove or pierce the steering wheel or hit it violently.



Side air bags

This is a system which protects the driver and front passenger in the event of a serious side impact in order to limit the risk of injury to the chest.

Each side air bag is incorporated in the front seat back frame, on the door side.

Activation

It is triggered unilaterally in the event of a serious side impact applied to all or part of the side impact zone **B**, perpendicular to the longitudinal centreline of the vehicle on a horizontal plane and directed from the outside towards the inside of the vehicle.

The side air bag inflates between the front occupant of the vehicle and the corresponding door trim pad.

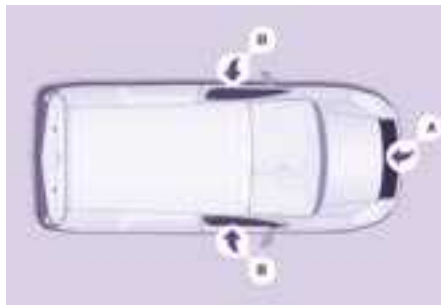

Impact detection zones

- A.** Front impact zone.
- B.** Side impact zone.

 In the event of a minor impact or bump on the side of the vehicle or if the vehicle rolls over, the air bag may not be triggered.

Operating fault



If this warning light comes on on the instrument panel, accompanied by an audible signal and a message on the display, contact a CITROËN dealer to have the system checked. The air bags may no longer be triggered in the event of a serious impact.

Curtain air bags

This is a system which protects the driver and passengers in the event of a serious side impact in order to limit the risk of head injuries.

Each curtain air bag is incorporated in the pillars and the upper part of the passenger compartment.

Activation

It is triggered at the same time as the corresponding side air bag in the event of a serious side impact applied to all or part of the side impact zone **B**, perpendicular to the longitudinal centreline of the vehicle on a horizontal plane and directed from the outside towards the inside of the vehicle.

The curtain air bag inflates between the occupant of the vehicle and the windows.

GENERAL POINTS RELATING TO CHILD SEATS

Although one of CITROËN's main criteria when designing your vehicle, the safety of your children also depends on you.

For maximum safety, please follow these precautions:

- all children under the age of 12 or less than one metre fifty tall must travel in approved child seats suited to their weight, on seats fitted with a seat belt or ISOFIX mountings.
- statistically, the safest seats in your vehicle for the transportation of children are the rear seats,
- a child weighing less than 9 kg must travel in the "rearwards-facing" position both in the front and in the rear,
- the passenger must not travel with a child on his lap.

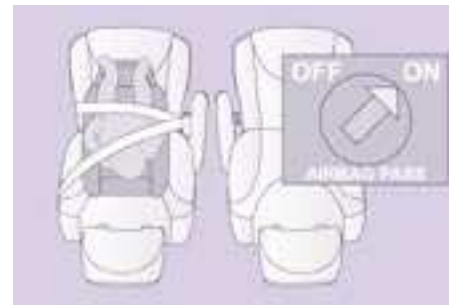
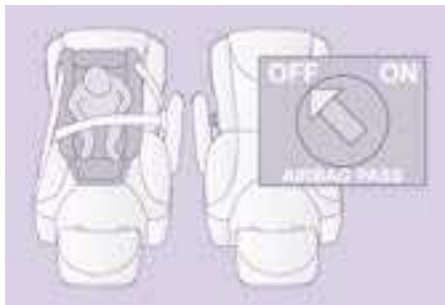

INSTALLING A CHILD SEAT USING A THREE POINT SEAT BELT

"Rearwards-facing"

Recommended on the rear seats up to the age of 2.

When a "rearwards-facing" child seat is installed on the front passenger seat, it is essential that the passenger air bag is disarmed. Otherwise, the child would risk being seriously injured or killed if the air bag were to inflate.

"Forwards-facing"

Recommended on the rear seats over the age of 2.

When a "forwards-facing" child seat is installed on the front passenger seat, leave the passenger air bag armed.

The rules for transporting children are specific to each country. Consult the current legislation in your country. Please consult the list of seats approved in your country. The isofix mountings, the rear seats, the passenger air bag and the disarming of this air bag depend on the version sold.

Child safety



+ Refer to chapter 5, "Air bags" section.

i The child seats function and the passenger air bag disarming function are common to the entire CITROËN range.

If the passenger air bag is not disarmed, the installation of a "rearwards-facing" child seat in the front is strictly prohibited.

UNIVERSAL CHILD SEATS RECOMMENDED BY CITROËN

CITROËN offers a complete range of recommended child seats which are secured using a three point seat belt:

Group 0: from birth to 10 kg

Group 0+: from birth to 13 kg



L1

"ROMER Baby-Safe Plus"

Installed in the rear-facing position

Groups 1, 2 and 3: from 9 to 36 kg



L2

"KIDDY Life"

For the safety of young children (from 9 to 18 kg), CITROËN recommends use of the restraining cushion.

Groups 2 and 3: from 15 to 36 kg



L3

"RECARO
Start"





L4

"KLIPPAN Optima"
From the age of
6 years
(approximately 22 kg),
the booster is used on
its own.

INSTALLING CHILD SEATS ATTACHED USING THE SEAT BELT

In accordance with European regulations, this table indicates the options for installing child seats secured using a seat belt and universally approved in accordance with the weight of the child and the seat in the vehicle.

Seat			Weight of the child and indicative age			
			Under 13 kg (groups 0 (a) and 0+) Up to approx 1 year	From 9 to 18 kg (group 1) 1 to 3 years approx	From 15 to 25 kg (group 2) 3 to 6 years approx	From 22 to 36 kg (group 3) 6 to 10 years approx
Row 1 (b)		Individual seat	U	U	U	U
		Bench, side seat	U	U	U	U
		Bench, centre seat (c)	U	U	U	U

a: Group 0: from birth to 10 kg.

b: consult the legislation in force in your country before installing your child on this seat.

c: the "RÖMER Baby-Safe Plus" child seat cannot be installed on this seat.

U: seat suitable for the installation of a child seat secured using a seat belt and universally approved, "rear facing" and/or "forward facing".

CITROËN advises against installing a child seat on the centre seat, with the exception of the "KLIPPAN Optima".

ADVICE ON CHILD SEATS

The incorrect installation of a child seat in a vehicle compromises the child's protection in the event of an accident.

Remember to fasten the seat belts or the child seat harnesses **keeping the slack** in relation to the child's body **to a minimum**, even for short journeys.

For optimum installation of the "forward facing" child seat, ensure that the back of the child seat is in contact with the back of the vehicle's seat and that the head restraint does not cause any discomfort.

If the head restraint has to be removed, ensure that it is stored or attached securely to prevent it from being thrown around the vehicle in the event of sharp braking.

Children under the age of 10 must not travel in the "forward facing" position on the front passenger seat, unless the rear seats are already occupied by other children, cannot be used or are absent.

Disarm the passenger air bag when a "rear facing" child seat is installed on the front seat.

Otherwise, the child would risk being seriously injured or killed if the air bag were to inflate.

As a safety precaution, do not leave:

- one or more children alone and unsupervised in a vehicle,
- a child or an animal in a vehicle which is exposed to the sun, with the windows closed,
- the keys within reach of children inside the vehicle.

To prevent accidental opening of the doors, use the "Child Lock".

Take care not to open the rear windows by more than one third.

To protect young children from the rays of the sun, fit side blinds to the rear windows.

Installing a booster seat

The chest part of the seat belt must be positioned on the child's shoulder without touching the neck.

Ensure that the lap part of the seat belt passes correctly over the child's thighs.

CITROËN recommends the use of a booster seat which has a back, fitted with a seat belt guide at shoulder level.

Child safety



+ Refer to chapter 5, "Air bags" section.

i The child seats function and the passenger air bag disarming function are common to the entire CITROËN range.

If the passenger air bag is not disarmed, the installation of a "rearwards-facing" child seat in the front is strictly prohibited.

UNIVERSAL CHILD SEATS RECOMMENDED BY CITROËN

CITROËN offers a complete range of recommended child seats which are secured using a three point seat belt:

Group 0: from birth to 10 kg

Group 0+: from birth to 13 kg



L1

"ROMER Baby-Safe Plus"

Installed in the rear-facing position

Groups 1, 2 and 3: from 9 to 36 kg



L2

"KIDDY Life"

For the safety of young children (from 9 to 18 kg), CITROËN recommends use of the restraining cushion.

Groups 2 and 3: from 15 to 36 kg



L3

"RECARO Start"



L4

"KLIPPAN Optima"
From the age of 6 years (approximately 22 kg), the booster is used on its own.

"ISOFIX" MOUNTINGS

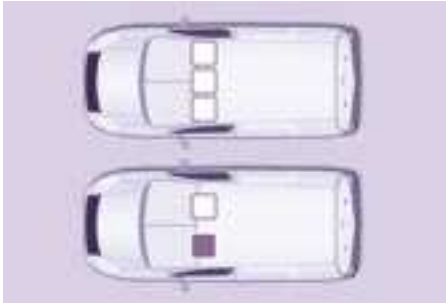

Your vehicle has been approved in accordance with the new ISOFIX regulation. The mountings comprise three rings for each seat:



- two front rings **A** and **B**, located between the vehicle seat back and cushion,



- a rear ring **C**, located on the back of the vehicle's seat back, for securing the upper strap referred to as the **TOP TETHER**.

This ISOFIX mounting system guarantees you fast, reliable and safe fitting of the child seat in your vehicle on the side seats.

The ISOFIX child seats are fitted with two locks which are secured easily on the two front rings.

Some also have an upper strap which is attached to the rear ring **C**.

- i** To attach this strap, raise the vehicle seat's head restraint then pass the hook between its rods. Then fix the hook on the rear ring and tighten the upper strap.

ISOFIX CHILD SEAT RECOMMENDED BY CITROËN AND APPROVED FOR YOUR VEHICLE

ISOFIX RÖMER Duo Plus
(size category **B1**)

Group 1: from 9 to 18 kg



Installed in the forward facing position.

Fitted with an upper strap to be secured on the ISOFIX upper ring, referred to as the **TOP TETHER**.

Three seat body angles: sitting, reclining, lying.

This child seat can also be used on seats which are not fitted with ISOFIX mountings.

In this case, it must be attached to the vehicle seat using the three point seat belt.

Follow the instructions for fitting the child seat given in the seat manufacturer's installation guide.

"ISOFIX" MOUNTINGS



Your vehicle has been approved in accordance with the new ISOFIX regulation. The mountings comprise three rings for each seat:



- two front rings **A** and **B**, located between the vehicle seat back and cushion,



- a rear ring **C**, located on the back of the vehicle's seat back, for securing the upper strap referred to as the TOP TETHER.

This ISOFIX mounting system guarantees you fast, reliable and safe fitting of the child seat in your vehicle on the side seats.

The ISOFIX child seats are fitted with two locks which are secured easily on the two front rings.

Some also have an upper strap which is attached to the rear ring **C**.

- i** To attach this strap, raise the vehicle seat's head restraint then pass the hook between its rods. Then fix the hook on the rear ring and tighten the upper strap.

ISOFIX CHILD SEAT RECOMMENDED BY CITROËN AND APPROVED FOR YOUR VEHICLE

ISOFIX RÖMER Duo Plus
(size category **B1**)

Group 1: from 9 to 18 kg



Installed in the forward facing position.

Fitted with an upper strap to be secured on the ISOFIX upper ring, referred to as the TOP TETHER.

Three seat body angles: sitting, reclining, lying.

This child seat can also be used on seats which are not fitted with ISOFIX mountings.

In this case, it must be attached to the vehicle seat using the three point seat belt.

Follow the instructions for fitting the child seat given in the seat manufacturer's installation guide.

SUMMARY TABLE FOR THE INSTALLATION OF ISOFIX CHILD SEATS

In accordance with European regulations, this table indicates the options for the installation of ISOFIX child seats on the vehicle seats fitted with ISOFIX mountings.

In the case of the universal and semi-universal ISOFIX child seats, the child seat's ISOFIX size category, determined by a letter from **A** to **G**, is indicated on the child seat next to the ISOFIX logo.

Weight of the child/indicative age										
Type of ISOFIX child seat	Less than 10 kg (group 0) Up to 6 months approx		Less than 10 kg (group 0) Less than 13 kg (group 0+) Up to 1 year approx			From 9 to 18 kg (group 1) From 1 to 3 years approx				
	Infant car seat		"rear facing"			"rear facing"		"forward facing"		
ISOFIX size category	F	G	C	D	E	C	D	A	B	B1
Row 1	X		IL-SU			IL-SU		IUF, IL-SU		

IUF: Seat suitable for the installation of an ISOFIX child seat of the universal category. "Forward facing" ISOFIX child seat fitted with an upper strap secured to the upper ring of the vehicle seats equipped with ISOFIX mountings.

IL-SU: Seat suitable for the installation of a semi-universal ISOFIX child seat. "Forward facing" ISOFIX child seat fitted with a stay. "Rear facing" ISOFIX child seat or infant car seat, fitted with an upper strap or a stay.

X: No restraining system for children.

"ISOFIX" MOUNTINGS



Your vehicle has been approved in accordance with the new ISOFIX regulation. The mountings comprise three rings for each seat:



- two front rings **A** and **B**, located between the vehicle seat back and cushion,



- a rear ring **C**, located on the back of the vehicle's seat back, for securing the upper strap referred to as the **TOP TETHER**.

This ISOFIX mounting system guarantees you fast, reliable and safe fitting of the child seat in your vehicle on the side seats.

The ISOFIX child seats are fitted with two locks which are secured easily on the two front rings.

Some also have an upper strap which is attached to the rear ring **C**.

- i** To attach this strap, raise the vehicle seat's head restraint then pass the hook between its rods. Then fix the hook on the rear ring and tighten the upper strap.

ISOFIX CHILD SEAT RECOMMENDED BY CITROËN AND APPROVED FOR YOUR VEHICLE

ISOFIX RÖMER Duo Plus
(size category **B1**)

Group 1: from 9 to 18 kg



Installed in the forward facing position.

Fitted with an upper strap to be secured on the ISOFIX upper ring, referred to as the **TOP TETHER**.

Three seat body angles: sitting, reclining, lying.

This child seat can also be used on seats which are not fitted with ISOFIX mountings.

In this case, it must be attached to the vehicle seat using the three point seat belt.

Follow the instructions for fitting the child seat given in the seat manufacturer's installation guide.



TOWING A TRAILER, CARAVAN, BOAT, ETC...

+ For more information about weights, refer to the administrative documents (V5 registration document, ...) or to the "Weights" section of chapter 9.

Driving advice

A towed vehicle must free wheel: gearbox in neutral.

Distribution of loads

Distribute the load in the trailer so that the heaviest objects are as close as possible to the axle and the nose weight is close to the maximum authorised without, however, exceeding it.

Cooling

Towing a trailer on a slope increases the coolant temperature.

As the fan is electrically controlled, its cooling capacity is not dependent on the engine speed.

On the contrary, use a high gear to lower the engine speed and reduce your speed.

In all cases, pay attention to the coolant temperature.

Towing a trailer

Good Practice

In certain cases of particularly arduous use (towing the maximum load up a steep slope in high temperatures), the engine automatically limits its power. In this case, the automatic cutting off of the air conditioning allows the engine power to be recovered.



If the coolant temperature warning light comes on, stop the vehicle and switch off the engine as soon as possible.



See the "Levels" section of chapter 7.



Tyres: check the tyre pressures of the towing vehicle (see the "Identification features" section of chapter 9) and of the trailer, observing the recommended pressure.

Brakes

Towing increases the braking distance. Drive at a moderate speed, change down early and brake gradually.

Side wind

Sensitivity to side wind is increased. Drive smoothly and at a moderate speed.

ABS/ESP

The ABS or ESP systems only control the vehicle, not the trailer or caravan.

Rear parking assistance

The assistance does not function while the vehicle is towing.

Towbar

We recommend the use of original CITROËN towbars and their harnesses, which have been tested and approved from the design stage of your vehicle, and that you entrust the fitting of this equipment to a CITROËN dealer.

If this equipment is not fitted by a CITROËN dealer, it is imperative that it is fitted using the electrical pre-equipment installed at the rear of the vehicle and in accordance with the manufacturer's instructions.

In accordance with the general instructions a reminder of which has been given above, we draw your attention to the risk linked with fitting a towbar or electrical accessory not recommended by CITROËN. Fitting such equipment could result in the failure of your vehicle's electronic system. Please contact a CITROËN dealer for information before fitting this type of equipment.

OTHER ACCESSORIES

These accessories and parts, having been tested and approved for reliability and safety, are all adapted to your vehicle. A wide range of recommended accessories and original parts is offered.

Range of professional equipment

The parts department publishes an accessories catalogue offering various equipment and fittings, such as:

Load retainers (all models).
Loading roller.

Towbar, towbar harness: trailer towbar which must be fitted by the CITROËN network.

Separation partitions and grilles, smooth, non-slip wooden protective floor.

Protective grilles.

Another range is also available, structured around comfort, leisure and maintenance:

Anti-theft alarm, window engraving, first aid kit, high visibility safety jacket, rear parking assistance, warning triangle, ...

Front seat covers compatible with air bags, bench, rubber mats, carpet mats, snow chains, blind, tailgate bicycle carrier, ...

Towing a trailer

Good Practice

In certain cases of particularly arduous use (towing the maximum load up a steep slope in high temperatures), the engine automatically limits its power. In this case, the automatic cutting off of the air conditioning allows the engine power to be recovered.



If the coolant temperature warning light comes on, stop the vehicle and switch off the engine as soon as possible.



See the "Levels" section of chapter 7.



Tyres: check the tyre pressures of the towing vehicle (see the "Identification features" section of chapter 9) and of the trailer, observing the recommended pressure.

Brakes

Towing increases the braking distance. Drive at a moderate speed, change down early and brake gradually.

Side wind

Sensitivity to side wind is increased. Drive smoothly and at a moderate speed.

ABS/ESP

The ABS or ESP systems only control the vehicle, not the trailer or caravan.

Rear parking assistance

The assistance does not function while the vehicle is towing.

Towbar

We recommend the use of original CITROËN towbars and their harnesses, which have been tested and approved from the design stage of your vehicle, and that you entrust the fitting of this equipment to a CITROËN dealer.

If this equipment is not fitted by a CITROËN dealer, it is imperative that it is fitted using the electrical pre-equipment installed at the rear of the vehicle and in accordance with the manufacturer's instructions.

In accordance with the general instructions a reminder of which has been given above, we draw your attention to the risk linked with fitting a towbar or electrical accessory not recommended by CITROËN. Fitting such equipment could result in the failure of your vehicle's electronic system. Please contact a CITROËN dealer for information before fitting this type of equipment.

OTHER ACCESSORIES

These accessories and parts, having been tested and approved for reliability and safety, are all adapted to your vehicle. A wide range of recommended accessories and original parts is offered.

Range of professional equipment

The parts department publishes an accessories catalogue offering various equipment and fittings, such as:

Load retainers (all models).
Loading roller.

Towbar, towbar harness: trailer towbar which must be fitted by the CITROËN network.

Separation partitions and grilles, smooth, non-slip wooden protective floor.

Protective grilles.

Another range is also available, structured around comfort, leisure and maintenance:

Anti-theft alarm, window engraving, first aid kit, high visibility safety jacket, rear parking assistance, warning triangle, ...

Front seat covers compatible with air bags, bench, rubber mats, carpet mats, snow chains, blind, tailgate bicycle carrier, ...



To prevent the mat from becoming caught under the pedals:

- ensure that the mat and its fixings are positioned correctly,
- never fit one mat on top of another.

Audio equipment, hands-free kit, speakers, CD changer, navigation, ...

Regardless of the audio and telematic equipment offered on the market, the technical constraints linked with the fitting of equipment of these families of products mean that the special features of the equipment and its compatibility with the capacities of the your vehicle's standard equipment must be taken into account. Please contact a CITROËN dealer for information before fitting such equipment.

Maximum weights on bars

- Roof rack: 120 Kg.
- Transverse bars on roof: 100 Kg.
- Transverse bars on longitudinal bars: 75 Kg.

Installation of radiocommunication transmitters

Before installing accessory radiocommunication transmitters with an external aerial on your vehicle, you are advised to contact a representative of the CITROËN marque.

The CITROËN Network will inform you of the specifications (frequency band, maximum output power, aerial position, specific installation conditions) of the transmitters which can be fitted, in accordance with the Motor Vehicle Electromagnetic Compatibility Directive (2004/104/CE).

Front mud flaps, rear mud flaps, 15/17 inch alloy wheels, wheelarch trim, leather steering wheel, ...

Screenwash, interior and exterior cleaning and maintenance products, replacement bulbs, ...

 The fitting of electrical equipment or accessories which are not recommended by Automobiles CITROËN may result in the failure of your vehicle's electronic system. Please note this specific warning. You are advised to contact a representative of the Marque to be shown the range of recommended equipment and accessories.

Depending on the country in which the vehicle is sold or operated, it is compulsory to have a high visibility safety jacket, warning triangle and replacement bulbs available in the vehicle.

"Active Fleet Data" Telematic unit

Connected directly to the heart of the vehicle (multiplexed network: "Full CAN"), the telematic unit, by means of a "ready to use" service, permits the sending in real time of information such as:

- distance travelled,
- distance remaining before the next service,
- warnings and faults (oil level, coolant level, oil temperature, coolant temperature, etc...).

This enables "Fleet" managers to optimise the monitoring and management of their professional vehicles.

According to country, contact a CITROËN dealer for further information.



OPENING THE BONNET

On the inside

Pull the lever under the fascia panel towards you. The bonnet is unlocked.



On the outside

Raise the bonnet slightly by reaching in a flat hand, palm down, to make access to the lever easier.

With this hand, push the lever to the left. Raise the bonnet.



Bonnet strut

Secure the strut in its location, identified by a sticker on the left-hand panel side of the vehicle, to hold the bonnet open.

Before closing the bonnet, put the strut back in its clip without using excessive force.

To close

Lower the bonnet and release it at the end of its travel. Check that the bonnet is locked.

Avoid manoeuvring the bonnet in strong winds.



PETROL ENGINE

Take care when working under the bonnet.

- 1. Windscreen wash reservoir.
- 2. Fuse box.
- 3. Engine coolant reservoir.

- 4. Brake and clutch fluid reservoir.
- 5. Air filter.
- 6. Dipstick.

- 7. Engine oil filler cap.
- 8. Power steering fluid reservoir.

i Battery connections:

- + Positive metal point.
- Negative metal point (earth).



DIESEL ENGINE

Take care when working under the bonnet.

- | | | |
|-------------------------------|--------------------------------------|------------------------------------|
| 1. Windscreen wash reservoir. | 4. Brake and clutch fluid reservoir. | 7. Engine oil filler cap. |
| 2. Fuse box. | 5. Air filter. | 8. Power steering fluid reservoir. |
| 3. Engine coolant reservoir. | 6. Dipstick. | 9. Priming pump. |

i Battery connections:

- + Positive metal point.
- Negative metal point (earth).

Levels

LEVELS

i These regular maintenance operations will keep your vehicle in good running order. Consult the instructions at a CITROËN dealer or in the servicing booklet enclosed in the handbook pack.

👁 If you have to remove/refit the engine style cover, handle it with care to avoid damaging the fixing clips.

Oil level

Check the level regularly and top up between changes. The maximum consumption is 0.5 litre per 600 miles (1 000 km).

Check the level with the vehicle level, engine cold, using the dipstick.

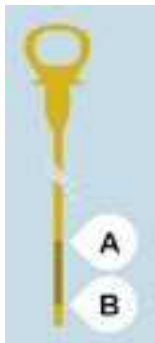

Dipstick

There are two marks on the dipstick:

A = maximum

If you fill past this mark, consult a CITROËN dealer.

B = minimum

Never allow the level to fall below this mark.

To maintain the reliability of engines and emission control systems, the use of additives in engine oil is prohibited.



Oil change

It is imperative that this is carried out at the intervals specified and the viscosity grade of the oil selected must fulfil the requirements in accordance with the manufacturer's servicing schedule. Consult the instructions at a CITROËN dealer.

Remove the dipstick before filling.

Check the level after filling (never exceed the max mark).

Screw the cap back onto the sump before closing the bonnet.

Viscosity selection

In all cases, the oil selected must meet the manufacturer's requirements.



Changing the brake fluid

The brake fluid must be changed at the intervals stated, according to the manufacturer's servicing schedule.

Use fluids recommended by the manufacturer, which fulfil DOT4 standards.

The level must be between the MIN and MAX marks on the reservoir.

If fluid has to be added frequently, this indicates a failure which must be checked by a CITROËN dealer as soon as possible.

Warning lights

+ Checking by means of the warning lights on the instrument panel is described in chapter 2, refer to the "Instruments and controls" section.

Cooling system

Only use the fluid recommended by the manufacturer.

Otherwise, you risk seriously damaging your engine.

When the engine is warm, the temperature of the coolant is controlled by the engine fan. As this fan can operate with the ignition key removed and because the cooling system is pressurised, wait for at least one hour after the engine has stopped before carrying out any work.

Slacken the cap by 1/4 of a turn to release the pressure to prevent any risk of scalding. When the pressure has dropped, remove the cap and top up the level with coolant.

If fluid has to be added frequently, this indicates a failure which must be checked by a CITROËN dealer as soon as possible.

Topping up

The level must be between the MIN and MAX marks on the expansion bottle. If more than 1 litre of fluid is required to top up the level, have the system checked by a CITROËN dealer.

Power steering fluid level

The vehicle must be parked on level ground with the engine cold. Unscrew the cap integrated with the gauge and check the level which must be between the MIN and MAX marks.

Windscreen wash and headlamp wash level

For best quality cleaning and for your safety, we would advise that you use products of the CITROËN range.

For optimum cleaning and to avoid freezing, this fluid must not be topped up or replaced with water.

Capacity of the screenwash reservoir: approximately 4.5 litres.

If your vehicle is fitted with headlamp washers, the capacity of the reservoir is 7.5 litres.



Diesel additive level (Diesel with particle emission filter)

The minimum level of this additive is indicated by lighting of the service warning light, accompanied by an audible signal and a message on the display.

When this occurs with the engine running it is due to the start of saturation of the particle emission filter (exceptionally prolonged urban type driving conditions: low speed, long traffic jams, ...).

In order to regenerate the filter, you are advised to drive at a speed higher than 40 mph (60 km/h) for at least five minutes as soon as possible, when traffic conditions permit (until the message disappears and the service warning light is switched off).

During regeneration of the particle emission filter, relay noise may be heard under the fascia.

If the message is still displayed and if the service warning light remains on, consult a CITROËN dealer.

Topping up

It is imperative that this additive is topped up by a CITROËN dealer without delay.

Used oil

Avoid prolonged contact of used oil with the skin.

Brake fluid is harmful to health and very corrosive.

Do not dispose of used oil, brake fluid or coolant into drains or into the ground but into the containers dedicated to this use at CITROËN dealer.

Checks

CHECKS

Battery

At the start of winter, have your battery checked by a CITROËN dealer.

Brake pads

Brake pad wear depends on the style of driving, in particular for vehicles which are used in town, over short distances. It may be necessary to check the thickness of the pads, even between services.

Unless there is a leak on the circuit, a drop in the brake fluid level indicates that the brake pads are worn.

Brake disc/drum wear status

For any information relating to checking the brake disc/drum wear status, consult a CITROËN dealer.

Handbrake

Where the handbrake travel is too great or there is a reduction in the performance of the system, the handbrake should be adjusted, even between services.

Have the system checked by a CITROËN dealer.



Carbon filter and passenger compartment filter

An access flap below the glove box permits replacement of the filters.

The carbon filter permits continuous and effective filtering of dust.

If the passenger compartment filter becomes clogged, this may reduce the performance of the air conditioning system and generate unpleasant odours.

We recommend the use of a combined passenger compartment filter. By means of its second special active filter, it contributes to the purification of the air breathed by the occupants and the cleanliness of the passenger compartment (reduction of allergic symptoms, unpleasant odours and greasy deposits).

Refer to the servicing booklet to find out the replacement interval for these components.

Depending on the environment (dusty atmosphere...) and the use of the vehicle (urban driving...), change them twice as often if necessary.

Oil filter

Change the filter regularly in accordance with the servicing schedule.

Particle emission filter (Diesel)

It is imperative that particle emission filter maintenance is carried out by a CITROËN dealer.

On acceleration after the vehicle has been running for a prolonged period at very low speed or at idle, you may, in exceptional circumstances, notice the emission of water vapour at the exhaust. This water vapour does not have any adverse effect on vehicle handling or the environment.

Bleeding the water contained in the diesel filter



If this warning light comes on, bleed the filter. Otherwise bleed regularly each time the engine is drained.

To evacuate the water, unscrew the bleed screw located on the filter.

Operate until all of the water in the transparent pipe has been drained out then tighten the bleed screw.

HDi engines use advanced technology. All work requires a special qualification which is guaranteed by a CITROËN dealer.

According to country.

Manual gearbox

Have the level checked in accordance with the manufacturer's servicing schedule.

i To check the main levels and certain components, in accordance with the manufacturer's servicing schedule, refer to the pages of the servicing booklet which correspond to your vehicle's engine.

i Only use products recommended by CITROËN or products of equivalent quality and characteristics.

In order to optimise the operation of units as important as the braking circuit, CITROËN selects and offers specific products.

In order to avoid damaging the electrical units, high pressure washing to clean the engine compartment is strictly prohibited.

Fuel



The fuel tank must be filled **with the engine off.**

- Open the fuel filler flap.
- Insert the key, then turn it a quarter turn.
- Remove the cap and hook it onto the clip located on the inside of the flap.

A label affixed to the inside of the flap reminds you of the type of fuel to be used.

When filling the fuel tank, do not continue after the 3rd cut-off of the nozzle. This could cause malfunctions.

The capacity of the fuel tank is approximately 60 litres.

- After filling the fuel tank, lock the cap and close the flap.

FILLING WITH FUEL

Low fuel level



When the minimum fuel tank level is reached, this warning light comes on.

You then have **approximately 8 litres** of fuel remaining. Fill up without delay to avoid running out of fuel.



When filling with fuel, with the fuel filler flap open, ensure that no one attempts to open the sliding side door.

FUEL CIRCUIT DISARMED

In a serious collision, a mechanism automatically prevents fuel from reaching the engine.



The flashing of this warning light is accompanied by a message on the display.

Check that there is no odour or leakage of fuel outside the vehicle and re-establish the fuel supply:

- switch off the ignition (STOP position).
- remove the key.
- put the key back in the ignition.
- switch on the ignition and start.

DIESEL REPRIMING PUMP

If you should run out of fuel, it is necessary to re-prime the circuit:

- fill the fuel tank with at least five litres of diesel,
- squeeze and release the manual re-priming pump, under the bonnet under the protective cover,
- operate the starter until the engine starts.



Refer to the "Under the bonnet" section of chapter 7.

BATTERY

To charge the battery using a battery charger

- Disconnect the battery,
- Follow the instructions for use given by the battery charger manufacturer,
- Reconnect starting with the negative (-) terminal,
- Check that the terminals and connectors are clean. If they are covered with sulphate (white or greenish deposit), disconnect them and clean them.

To start the vehicle from another battery

- Connect the red cable to the positive (+) terminals of the two batteries,
- Connect one end of the green or black cable to the negative (-) terminal of the slave battery,
- Connect the other end of the green or black cable to an earth point on the broken down vehicle as far as possible from the battery,
- Operate the starter, let the engine run,
- Wait for the engine to return to idle, then disconnect the cables.



i It is advisable to disconnect the battery if the vehicle is not to be used for a period of more than one month.

Before disconnecting the battery, you must wait for 2 minutes after switching off the ignition.

Never disconnect a terminal when the engine is running.

Never charge a battery without first disconnecting the terminals.

After every reconnection of the battery, switch on the ignition and wait 1 minute before starting to allow the electronic systems to be initialised. If slight difficulties are experienced after this, please contact a CITROËN dealer.

After changing bulbs, wait approximately 3 minutes before reconnecting the battery.

ECONOMY MODE

After the engine has stopped, with the key in the ignition position, certain functions (windscreen wiper, electric windows, courtesy lights, audio equipment, etc.) can only be used for a cumulative duration of thirty minutes, to prevent discharging of the battery.

Once the thirty minutes are over, the active functions are put on standby and the battery warning light flashes accompanied by a message on the display.

To resume the use of these functions immediately, start the engine and let it run for a few minutes.

The time available will then be double the time for which the engine was left running. However, this time will always be between five and thirty minutes.

A flat battery will prevent the engine from starting.



CHANGING A WHEEL

1. PARKING THE VEHICLE

- It is imperative that you ensure that the occupants get out of the vehicle and wait in a safe location.
- If possible, park the vehicle on level, stable and non-slippery ground.
- Apply the handbrake, switch off the ignition and engage first or reverse gear.

- If available, place a chock under the wheel diagonally opposite the one to be changed.

If the vehicle is fitted with a towbar; it is sometimes necessary to raise the vehicle slightly to make it easier to remove the spare wheel from its carrier.

On certain types of ground and/or if considerable loads are being transported, call a CITROËN dealer.

2. TOOLS

- Open the lid of the storage compartment located under the seat on the right-hand side. If necessary, move the seat forward to access the storage compartment from the rear.
- Unscrew the nut then take out the jack and the wheelbrace.

1. Wheelbrace.
2. Jack.
3. Alloy wheel embellisher remover.
4. Chock.

The jack and the tool kit are specific to your vehicle. Do not use them for other purposes.

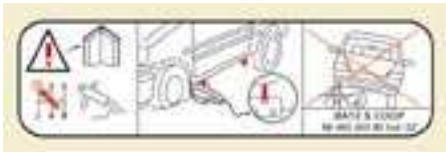



3. SPARE WHEEL

- Open the rear doors to gain access to the spare wheel.



- Unscrew the bolt using the wheelbrace until the carrier is lowered fully.



- Detach the carrier from the hook and place the spare wheel near the wheel to be changed.



4. OPERATING PROCEDURE

- Remove the trim pulling it using the embellisher remover.
- Loosen the wheel bolts and start unscrewing them.
- Place the jack in contact with the locating point provided, the one which is closest to the wheel to be changed. Ensure that the jack is straight and that the base of the jack is fully in contact with the ground.
- Extend the jack to lift the wheel clear of the ground.
- Resume and complete the unscrewing of the wheel bolts.
- Remove the bolts and remove the wheel.

Do not extend the jack until you have started unscrewing the bolts on the wheel to be changed and have placed the chock under the wheel diagonally opposite.

Anti-theft bolts

If your vehicle is fitted with wheels with alloy rims:

- Each wheel has an anti-theft bolt.
- These bolts can be loosened using your anti-theft socket (given to you in delivery of your vehicle) and the wheelbrace.



5. FITTING THE SPARE WHEEL

- Position the wheel on the hub and start tightening the bolts by hand.
- Carry out an initial tightening of the bolts using the wheelbrace.
- Lower the vehicle completely by folding the jack, then remove the jack.
- Tighten the bolts again using the wheelbrace, tighten them fully without forcing them.
- Place the wheel to be repaired in the carrier.
- Secure the carrier on the hook then raise the carrier using the bolt and the wheelbrace.



Never go underneath a vehicle that is supported only by a jack (use a ramp). Never use a screwdriver in place of the wheelbrace.



Snow screen

6. REFITTING THE REPAIRED WHEEL

The wheel is refitted as described in step 5, not forgetting to refit the wheel trim.

+ Refer to the "Identification features" section of chapter 9 to locate the tyre label.

+ Refer to the "Instruments and controls" section of chapter 2, "Tyre under-inflation detection" part, for recommendations after changing a wheel fitted with a tyre under-inflation detection sensor.

i The spare wheel is not designed to be used over long distances. Have the tightening of the bolts and the tyre pressure checked by a CITROËN dealer as soon as possible. Also, have the original wheel repaired and refitted by a CITROËN dealer as soon as possible.

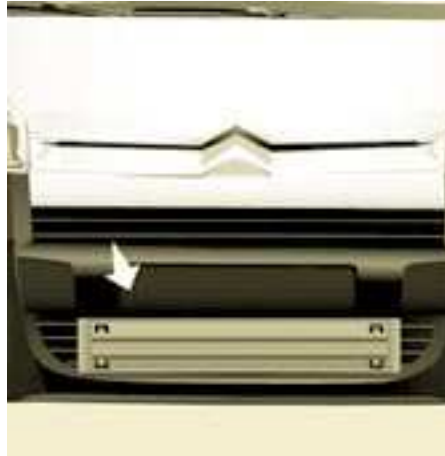

REMOVABLE SNOW SCREEN

According to country, the removable snow screen is installed on the lower part of the front bumper to prevent the accumulation of snow at the radiator cooling fan.

Do not forget to remove the snow screen when the exterior temperature is higher than 10 °C (no risk of snowfall) and when towing.

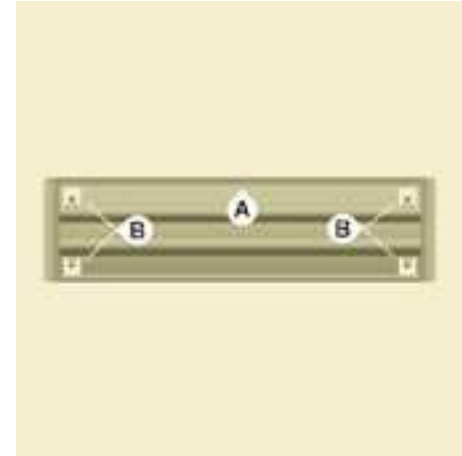

FITTING

- Offer up the snow screen facing its centring pin **A** on the front bumper.
- Put it in place by pressing at each clip **B** located in the four corners.

REMOVAL

- Pass a screwdriver into the hole located near each of the clips.
- Use the screwdriver as a lever to unclip the four clips **B** in turn.

Snow screen

6. REFITTING THE REPAIRED WHEEL

The wheel is refitted as described in step 5, not forgetting to refit the wheel trim.

+ Refer to the "Identification features" section of chapter 9 to locate the tyre label.

+ Refer to the "Instruments and controls" section of chapter 2, "Tyre under-inflation detection" part, for recommendations after changing a wheel fitted with a tyre under-inflation detection sensor.

i The spare wheel is not designed to be used over long distances. Have the tightening of the bolts and the tyre pressure checked by a CITROËN dealer as soon as possible. Also, have the original wheel repaired and refitted by a CITROËN dealer as soon as possible.

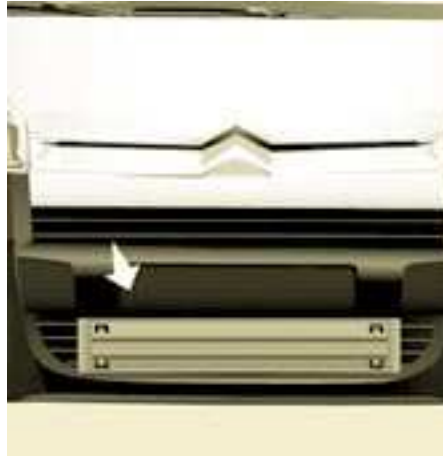

REMOVABLE SNOW SCREEN

According to country, the removable snow screen is installed on the lower part of the front bumper to prevent the accumulation of snow at the radiator cooling fan.

Do not forget to remove the snow screen when the exterior temperature is higher than 10 °C (no risk of snowfall) and when towing.

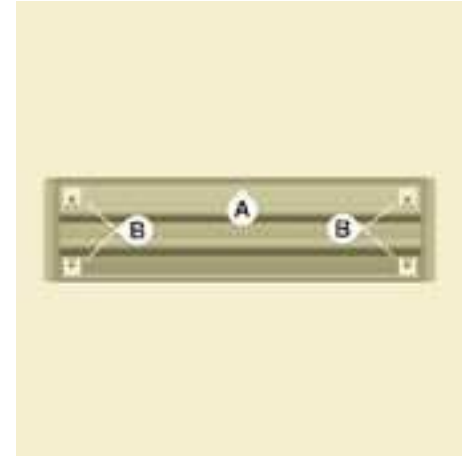

FITTING

- Offer up the snow screen facing its centring pin **A** on the front bumper.
- Put it in place by pressing at each clip **B** located in the four corners.

REMOVAL

- Pass a screwdriver into the hole located near each of the clips.
- Use the screwdriver as a lever to unclip the four clips **B** in turn.



CHANGING A BULB

Open the bonnet. To access the bulbs, reach behind the headlamp unit.

Carry out the operations in reverse order to refit each bulb and check that the bonnet is closed securely.

 Halogen bulbs must be changed with the headlamp off. Wait a few minutes (risk of serious burns).

Do not touch the bulb directly with your fingers, use lint-free cloths.

It is normal for condensation to form inside the headlamps. Regular use of the vehicle eliminates this misting.

The bulbs must be changed with the ignition off or with the battery disconnected. Wait approximately 3 minutes after changing the bulb before reconnecting the battery.

Check that the lights operate correctly after each operation.

High pressure washing

 When using this type of washing on stubborn dirt, do not persist on the headlamps, the lights and their surround to avoid damaging their coating and their seal.

Types of bulb

Various types of bulb are installed on your vehicle. To remove them:

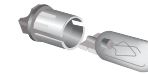

Type A

Entirely glass bulb: pull gently as it is fitted by pressure.

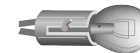

Type B

Bayonet bulb: press on the bulb then turn it anticlockwise.



Type C

Halogen bulb: release the retaining spring from its housing.





FRONT LIGHTS

1. Dipped headlamps/Main beam headlamps

Type C, H4 - 55 W

- Remove the centre cover by pulling the flexible rubber tab.
- Disconnect the electrical connector.
- Release the retaining tab.
- Change the bulb taking care to align the metal part with the grooves on the light.
- Reposition the retaining tab.
- Ensure that the cover is refitted correctly over its entire periphery to guarantee sealing.

2. Side lights

Type A, W 5 W - 5 W

- Remove the cover by pulling the flexible rubber tab.
- Remove the bulb holder fitted by pressure by pulling the connector.
- Change the bulb.
- Ensure that the cover is refitted correctly over its entire periphery to guarantee sealing.

3. Direction indicators

Type B, PY 21 W - 21 W (amber)

- Remove the cover by pulling the flexible rubber tab.
- Turn the bulb holder a quarter turn anticlockwise.
- Remove the bulb by pressing it lightly while turning it anticlockwise.
- Change the bulb.
- Ensure that the cover is refitted correctly over its entire periphery to guarantee sealing.

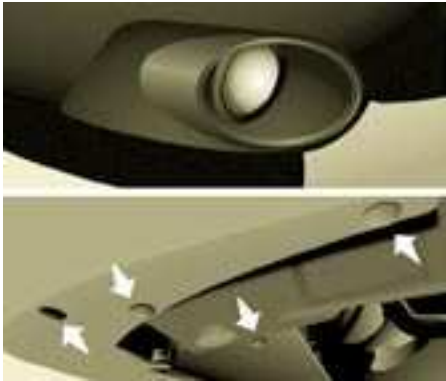

4. Fog lamps

Type C, H1 - 55 W

- Remove the fog lamp by removing the bolt, which can be accessed via the hole provided for this purpose in the bumper, using a Torx® 30 screwdriver.
- Remove the three mud guard fixing clips, located below the bumper.
- Move the mud guard upwards.
- Unclip the fog lamp by squeezing the clip to release it.
- Remove the fog lamp from the outside.
- Turn the yellow cover a 1/4 turn to open.
- Separate the clips which secure the base of bulb on each side to release the bulb.
- Remove the bulb by pulling, keeping it straight.
- Insert the new bulb, re-tighten the clips around the base of the bulb and carry out the operations in reverse order to put the light unit and the bumper back in position.



SIDE REPEATER

Type A, WY 5 W (amber)

- Push the repeater towards the rear and disengage it by pulling the front.
- Consult a CITROËN dealer to obtain a new repeater which is a fully moulded part.
- To refit, engage the repeater towards the rear and bring it towards the front.



Front/Rear

COURTESY LIGHTS

Type A, 12 V 5 W - 5 W

- Unclip the lens by sliding a screwdriver in the slots on each side of the courtesy light.
- Pull the bulb and change it.
- Clip the lens in its housing and ensure that it is secured correctly.

Changing a bulb

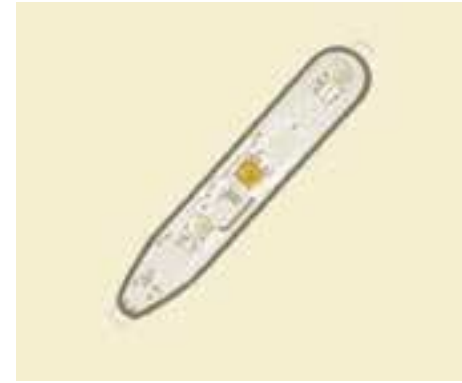

REAR LIGHTS

For further information concerning the bulbs, refer to the "Types of bulb".

1. Brake lights/side lights

Type B, P21/5 W - 21/5 W

2. Direction indicators

Type B, PY 21 W - 21 W (amber)

3. Reversing lights

Type B, P21 W - 21 W

4. Fog lamps

Type B, P21 W - 21 W

High pressure washing



When using this type of washing on stubborn dirt, do not persist on the headlamps, the lights and their surround to avoid damaging their coating and their seal.

- Identify the faulty bulb then open the rear doors to 180°. Refer to the "Accesses" section of chapter 2.
- Remove the two fixing bolts using the screwdriver stored in the tool kit under the right-hand seat.
- Pull the light unit from the outside.
- Holding the light, disconnect the electrical connector.

- Move aside the 4 tabs then extract the bulb holder.
- Remove the faulty bulb by pressing it lightly while turning it anticlockwise.
- Change the bulb.

When removing the light unit:

- with tailgate, pull the light unit towards the centre of the vehicle,
- with hinged doors, pull the light unit towards you.



When refitting, take care to reposition the tabs and the supply wire correctly to avoid trapping the wire.

After changing the rear direction indicator bulb, the reinitialisation time is more than approximately 2 minutes.



NUMBER PLATE LIGHTS

Type A, W 5 W - 5 W

With tailgate

- Move aside the plastic lens using a screwdriver.
- Change the bulb.
- Replace the plastic lens and press on it.

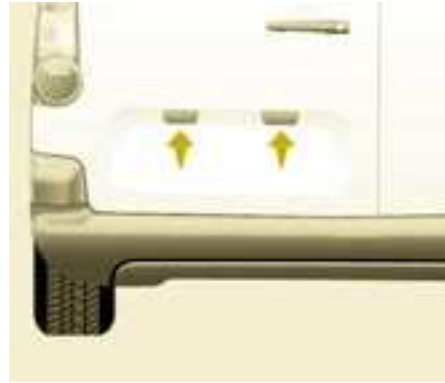

With hinged doors

- Unclip the interior trim.
- Disconnect the connector by moving aside its tab.
- Turn the bulb holder a quarter turn anticlockwise.
- Change the bulb.
- Put the bulb holder back in place and reconnect the connector.
- Put the trim back in place.



THIRD BRAKE LIGHT

Type A, W 16 W - 16 W

- Unscrew the two nuts.
- Push the pins.
- If necessary, disconnect the connector to remove the light.
- Change the bulb.

Changing a fuse

CHANGING A FUSE

The fuse boxes are placed:

- in the lower part of the fascia on the left-hand side (behind the cover),
- under the bonnet (near the battery).

If fitted on your vehicle, an additional fuse box is used for towing, the towbar and the connections for the coachbuilder and platform cab modifications. It is located on the right behind the load retaining partition.

The indications communicated are only those fuses which can be changed by the user using the pliers and the spare fuses, located behind the fascia storage compartment on the right-hand side. For any other work, visit a CITROËN dealer.

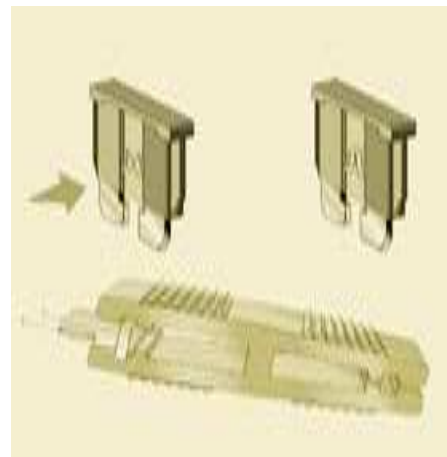

Removing and fitting a fuse

Before replacing a fuse, the cause of the incident must be found and rectified.

- Use the pliers.

i For professionals: for complete information concerning the fuses and relays, consult the "Methods" diagram via the Network.

Always replace a faulty fuse with a fuse of the same rating.

CITROËN will not accept responsibility for the cost incurred in repairing your vehicle or for rectifying the malfunctions resulting from the installation of accessories not supplied and not recommended by the CITROËN network and not installed in accordance with its instructions, in particular when the combined consumption of all of the additional equipment connected exceeds 10 milliamperes.

FASCIA FUSES

Tilt the cover to gain access to the fuses.

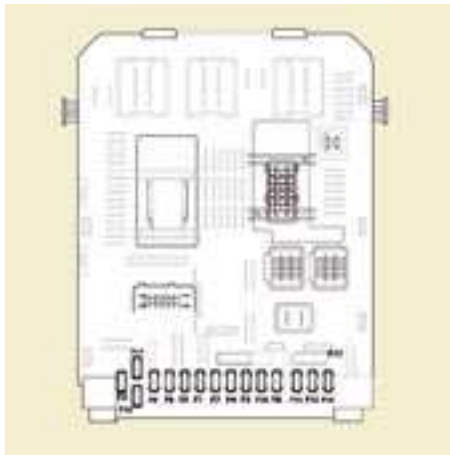

Fuses F	Amperes A	Allocation
1	15	Rear wiper
2	-	Spare
3	5	Air bag
4	10	Air conditioning, diagnostic socket, mirror control, headlamp beam
5	30	Electric windows
6	30	Locks
7	5	Rear courtesy light, front map reading light, roof console
8	20	Audio equipment, CD changer, display, tyre under-inflation detection, alarm and siren
9	30	Front and rear 12 V socket
10	15	Central column
11	15	Low current ignition switch
12	15	Rain and brightness sensor, air bag
13	5	Instrument panel
14	15	Parking assistance, automatic air conditioning controls, hands-free kit
15	30	Locks
16	-	Spare
17	40	Rear screen/mirrors de-icing

Changing a fuse

PASSENGER COMPARTMENT FUSES

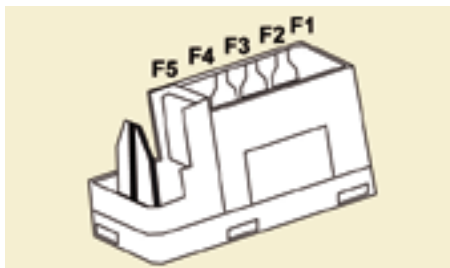

Fuses F	Amperes A	Allocation
1	-	Spare
2	20	Heated seats
3	-	Spare
4	15	Folding mirrors relay
5	15	Refrigeration equipment socket relay

TOWING/TOWBAR/ COACHBUILDERS/PLATFORM CAB FUSES

The designations communicated are an indication only as this additional box relates to other information which depends on the modifier-coachbuilder for which the handbook cannot be used as a technical support.

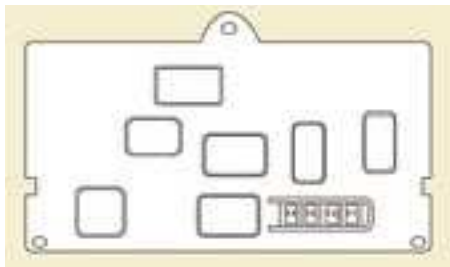

Fuses F	Amperes A	Allocation
1	15	Spare
2	15	Ignition, generator operating relay
3	15	Trailer 12 V supply
4	15	Permanent supply for the modifiers
5	40	Hazard warning lights

FUSES UNDER THE BONNET

After opening the bonnet, unclip and tilt the box to gain access to the fuses.

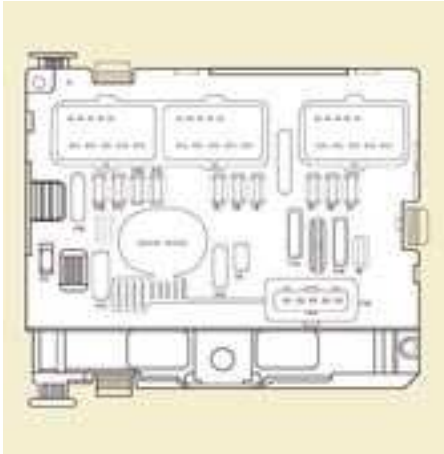

Fuses F	Amperes A	Allocation
1	20	Engine management
2	15	Horn
3	10	Front and rear wash-wipe pump
4	20	Headlamp wash pump
5	15	Engine components
6	10	Steering wheel angle sensor, ESP
7	10	Brake switch, clutch switch
8	25	Starter
9	10	Headlamp beam motor, parc management unit
10	30	Engine components
11	40	Spare
12	30	Wipers
13	40	Built-in systems interface
14	30	Pump
15	10	Right-hand main beam headlamp
16	10	Left-hand main beam headlamp
17	15	Right-hand dipped headlamp
18	15	Left-hand dipped headlamp



CHANGING A WINDSCREEN WIPER BLADE

Placing the wiper blades in the special position

- Less than a minute after switching off the ignition, press the wipers stalk downwards to position the wiper blades along the windscreen uprights (special position).

Changing a front wiper blade

- Lift the wiper arm.
- Unclip the blade and remove it.
- Fit the new blade.
- Push back the wiper arm.

To return the windscreen wipers to their normal position, switch on the ignition and operate the wipers stalk.

Changing the rear wiper blade

- Lift the wiper arm, then unclip the blade and remove it.
- Fit the new blade and push back the wiper arm.



BEING TOWED

The towing eye is stored in the tool kit, located under the right-hand seat.

Without lifting (4 wheels on the road)

You should always use a towbar.



From the front

- Unclip the cover by pressing the bottom part.
- Screw in the removable towing eye until it locks.

From the rear

- Unclip the cover using a coin or the flat part of the towing eye,
- Screw in the removable towing eye until it locks.

Lifting (2 wheels on the road only)

It is preferable to raise the vehicle using professional lifting equipment.

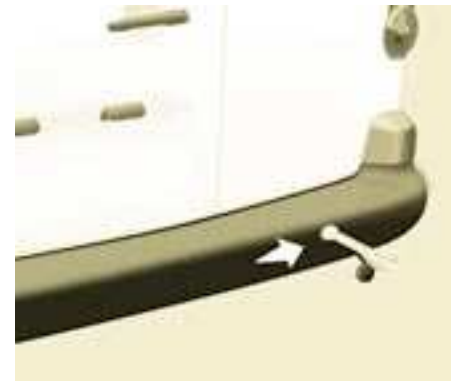



i When towing with the engine switched off, there is no braking or steering assistance.

In the case of vehicles fitted with a manual gearbox, the gear lever must be in neutral, failure to observe this special condition may result in damage to certain braking components and the absence of braking assistance when the engine is started again.

Vehicles fitted with a manual gearbox (diesel version)

In the case of vehicles fitted with a manual gearbox, the gear lever must be in the neutral position, failure to observe this special condition may result in damage to certain braking components and the absence of braking assistance when the engine is started again.

		mm
	L1	3.3
	L2	3.7



DIMENSIONS

The vehicle is available in 2 lengths (L1 and L2), refer to the tables:

		VAN (mm)		
		Short - L1		Long - L2
		625	850	750
L	Overall length	4 380		4 628
H	Overall height	1 805-1 834		
A	Wheelbase	2 728		
B	Front overhang	925		
C	Rear overhang	727	975	
D	Width over panels:	without mirrors	1 810	
		with mirrors	2 112	
E	Width of front tracks	1 505		
F	Width of rear tracks	1 554		
G	Useful length of rear floor	1 800	2 050	
I	Useful length with front passenger seat folded	3 000	3 250	

Dimensions

140

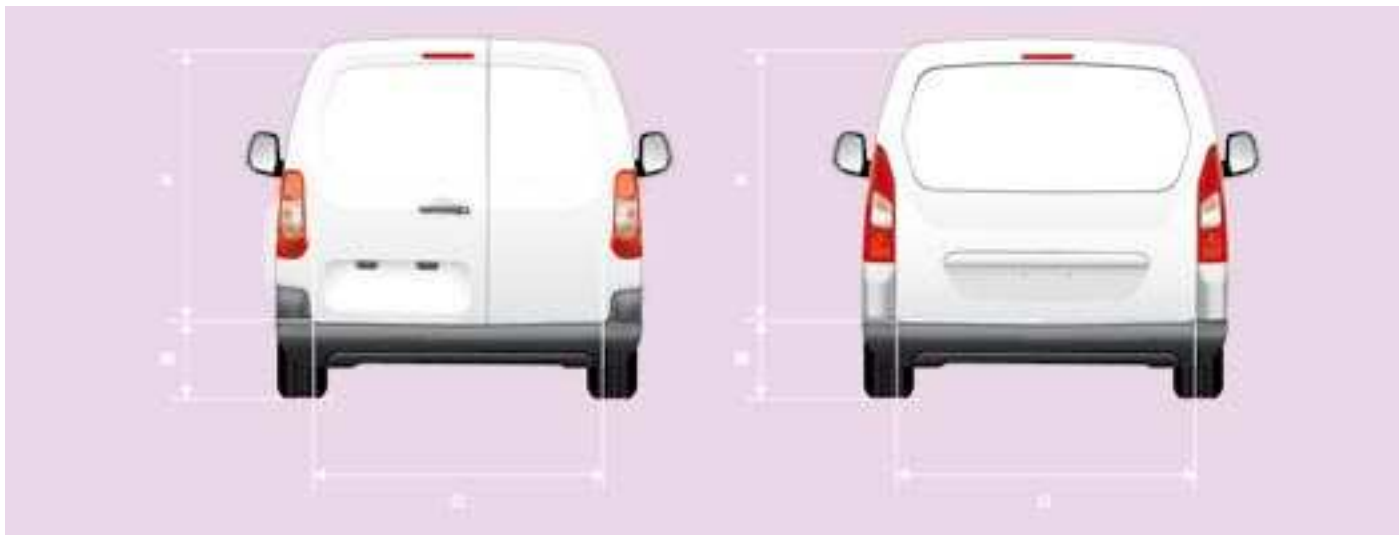

		REAR DOORS (mm)		
		L1 - 625	L1 - 850	L2
M	Maximum threshold with 195/65 R15 tyre	584	609	612
		Hinged doors		Tailgate
		Small	Large	
N	Useful opening height (under panel)	1 148		1 313
O	Width	495	543	1 582



		SLIDING SIDE DOOR (mm)	
		L1	L2
P	Useful height	1 100	
Q	Useful width	650	
-	Height under raised tailgate	1 892	

Dimensions

142



		PLATFORM CAB (mm)
L	Overall length	4 237
H	Overall height	1 821-1 822
A	Wheelbase	2 728
B	Front overhang	925
C	Rear overhang	584
D	Width over panels (without mirrors)	1 810
E	Width of front tracks	1 505
F	Width of rear tracks	1 554

WEIGHTS AND TOWED LOADS (KG)

General points

For further information, consult your registration certificate.

In each country, it is imperative that the towed loads authorised by local legislation are complied with. To find out your vehicle's towing capacities and its gross train weight, consult a CITROËN dealer.

The speed of a towing vehicle must not exceed 50 mph (80 km/h) (comply with the legislation in force in your country).

The braked towed weight with load transfer can be increased on condition that the equivalent of this load is removed from the vehicle so that the GTW is not exceeded. Warning: towing using a lightly loaded towing vehicle may have an adverse effect on its road holding.

The GTW and towed load values indicated are valid up to a maximum altitude of 1 000 metres; the towed load mentioned must be reduced by 10 % for each additional 1 000 metres.

High exterior temperatures may result in a reduction in the performance of the vehicle in order to protect the engine; when the exterior temperature is higher than 37 °C, limit the towed weight.

The kerb weight is equal to the weight without load + driver (75 kg) + fuel tank filled to 90 %.

GTW: gross train weight

GVW: gross vehicle weight

MOM: kerb weight

CVA: vertical load on the towbar

Weights

		Weights						Model codes		
		Number of seats	Engine	GTW	GVW	MOM	CVA	Body type	Engine code	Gearbox
Van	L1 - 625 kg	2	1.6 Petrol 90	2 935	1 960	1 413	40	7A	NFR	C
			1.6 HDi 75	2 935	1 960	1 411	40		9HT	
			1.6 HDi 90	3 135	1 960	1 411	50		9HX	
		3	1.6 Petrol 90	2 955	1 980	1 430	40	7B	NFR	C
			1.6 HDi 75	2 955	1 980	1 429	40		9HT	
			1.6 HDi 90	3 105	1 980	1 429	50		9HX	
	L1 - 850 kg	2	1.6 Petrol 90	2 935	2 185	1 413	30	7C	NFR	C
			1.6 HDi 75	2 935	2 185	1 411	30		9HT	
			1.6 HDi 90	3 135	2 185	1 411	40		9HX	
		3	1.6 Petrol 90	2 955	2 205	1 430	30	7D	NFR	C
			1.6 HDi 75	2 955	2 205	1 429	30		9HT	
			1.6 HDi 90	3 105	2 205	1 429	40		9HX	
L2 - 750 kg	2	1.6 HDi 90	3 130	2 130	1 459	40	7E	9HX	C	
	3	1.6 HDi 90	3 100	2 150	1 476	40	7F	9HX	C	
Platform cab	L1 - 1 000 kg	2	1.6 HDi 90	3 127	2 227	1 302	40	7G	9HX	C

	ENGINES AND GEARBOXES		
	Petrol	Diesel	
TVV	NFR	9HT	9HX
Name	1.6 PETROL	1.6 HDi	1.6 HDi
Power (bhp)	90	75	90
EU standard maximum power (kW/DIN)	66	55.2	66.2
Engine speed (rpm)	5 800	4 000	4 000
Cubic capacity (cm ³)	1 587	1 560	1 560
Gearbox - manual	5	5	5
Bore x stroke (mm)	78.5 x 82	75 x 88.3	75 x 88.3
EU standard max torque (Nm)	132	185	215
Max power engine speed (rpm)	2 500	1 750	1 750
Fuel	Unleaded	Diesel	
Catalytic converter	Yes	Yes	Yes

Diesel - Petrol engines

146

CONSUMPTION								
	Petrol		Diesel					
TVV	NFR		9HT		9HX			
Name	1.6 Petrol		1.6 HDi		1.6 HDi			
Body type	Short - L1		Short - L1		Short - L1		Long - L2	Platform cab
kg	625	850	625	850	625	850	750	1 000
Urban driving [mpg (l/100 km)]	26.2 (10.8)	26.2 (10.8)	40.4 (7.0)	40.4 (7.0)	40.4 (7.0)	40.4 (7.0)	40.4 (7.0)	37.7 (7.6)
Inter-urban driving [mpg (l/100 km)]	41.5 (6.8)	41.5 (6.8)	55.4 (5.1)	55.4 (5.1)	55.4 (5.1)	55.4 (5.1)	55.4 (5.1)	48.7 (5.8)
Mixed driving [mpg (l/100 km)]	34.4 (8.2)	34.4 (8.2)	48.7 (5.8)	48.7 (5.8)	48.7 (5.8)	48.7 (5.8)	48.7 (5.8)	43.5 (6.5)
Emission of CO ₂ by weight (g/km)	195	195	153	153	153	153	153	173

Consumption values correct at time of printing. These consumption values were established in accordance with Directive 80/1268/CEE. They may vary depending on the style of driving, traffic conditions, weather conditions, the load in the vehicle, the maintenance of the vehicle and the use of the accessories.



IDENTIFICATION FEATURES

A. Manufacturer's plate.

This is located on the engine mounting, on the right-hand side.

- 1 - VF Type serial number.
- 2 - Gross vehicle weight (GVW).
- 3 - Gross train weight (GTW).
- 4.1 - Maximum weight on front axle.
- 4.2 - Maximum weight on rear axle.

B. Serial number.

This is engraved on the front right wheelarch.

C. Tyres and paint colour reference.

The label **C**, on the front door gives:

- the wheel and tyre sizes,
- the brands of tyres approved by the manufacturer,
- the tyre pressures (the tyre pressure must be checked when the tyre is cold, at least once a month),
- the paint colour reference.