

EXTERIOR

Sunroof

This roof improves the ventilation and light in the passenger compartment.

» 81

Reversing camera

This equipment is activated automatically when reverse gear is engaged providing a visual return on the colour display.

» 117

**Audible rear parking assistance**

This equipment warns you if an obstacle is detected behind the vehicle when reversing.

» 116

Lower tailgate

This lower tailgate provides remarkable accessibility and makes the loading of bulky objects easier.

» 80

OPENING

Remote control key



- A. Unfolding/folding of the key.
- B. Unlocking of the vehicle.
- C. Locking of the vehicle.

Manual centralised control



1. Locking of the vehicle.
2. Unlocking of the vehicle.

Fuel tank

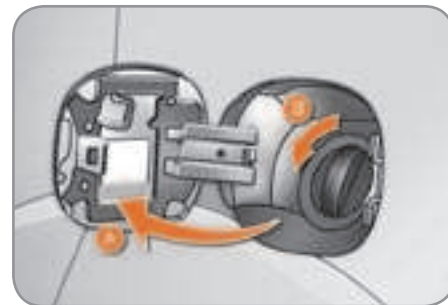

- A. Opening of the fuel filler flap.
- B. Opening of the fuel tank cap.

Capacity of the tank: approximately 60 litres.

When refitting the cap, insert the upper part first turning it to the right.

OPENING

Tailgate

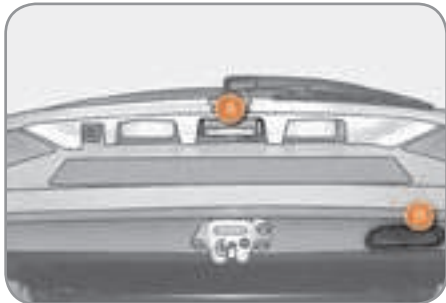

Opening

- ☞ After unlocking the vehicle using the remote control or the key, press the handle **A** and raise the tailgate.

Closing

- ☞ Pull the handle **B** downwards.

Lower tailgate

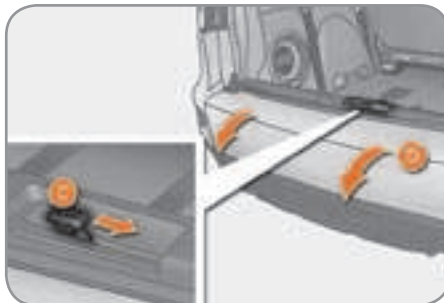

Opening

- ☞ Push the handle **C** to the right and tilt the tailgate **D** gently.

Closing

- ☞ Raise the tailgate **D**, push it to close it, then check that it is secured correctly.



The maximum authorised weight on the lower tailgate when open is **200 kg**.

Spare wheel and tools



Access to the spare wheel

- ☞ Remove the plastic cover **E** to gain access to the spare wheel fixing system.

Access to the tools

The tools are stored in the storage compartment **F** in the boot right-hand trim.

CONFIGURING

Rear seats (row 2)



Forwards-backwards adjustment



Head restraint height adjustment

» 50



Seat back angle adjustment

» 51



Access to the third row
(7-seat version)

» 52

Rear bench seat (row 3)



The rear bench seat can be folded. It retracts into a location in the floor of the vehicle.

» 56

INTERIOR

Automatic air conditioning

This automatic air conditioning system guarantees comfort and a sufficient circulation of air in the passenger compartment.

» 44

Audio and communication systems

This equipment benefits from the latest technology: MP3 compatible audio equipment, Bluetooth hands-free telephone, colour display, Rockford Fosgate audio system, auxiliary sockets.

» 154

Cruise control

This system automatically maintains the vehicle speed at the value programmed by the driver, without the accelerator pedal being pressed.

» 114

Four wheel drive system with electronic control

This system permits the selection of a transmission mode in relation to the driving conditions.

» 112

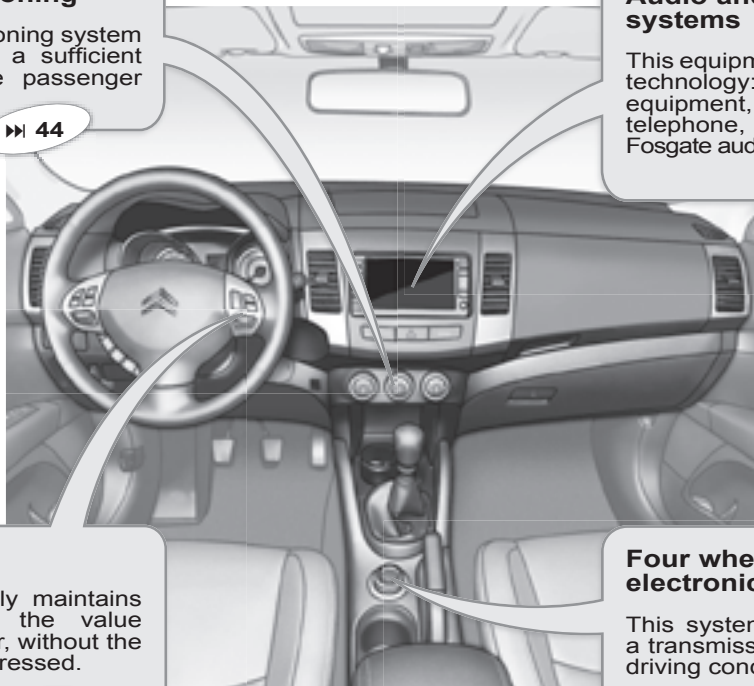

INSTRUMENTS AND CONTROLS

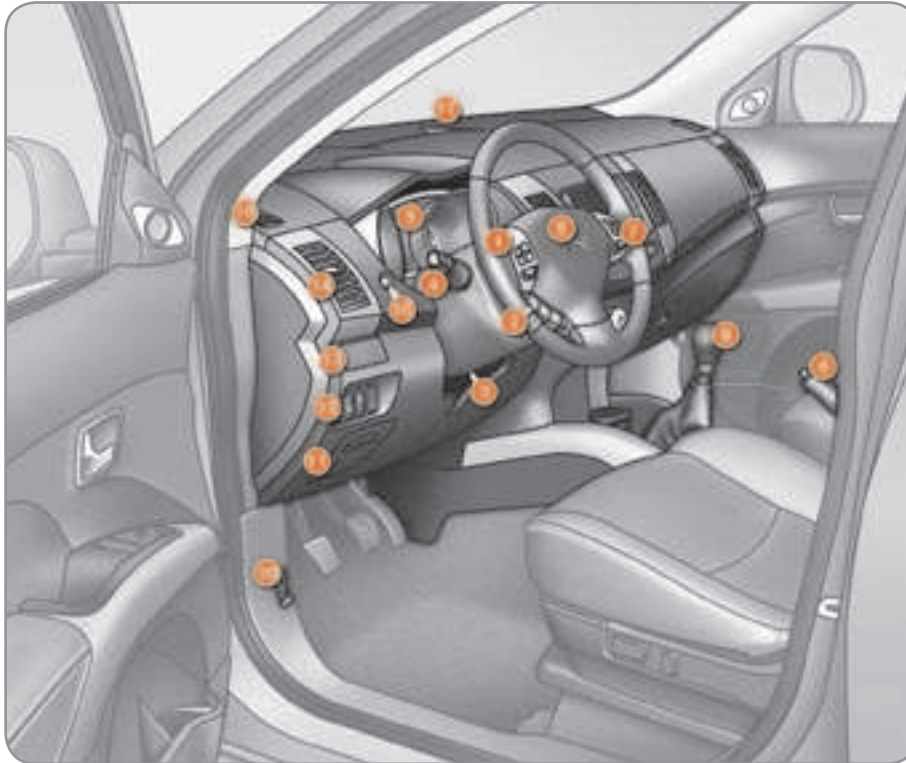

1. Audio equipment controls.
2. Telephone controls.
3. Steering wheel adjustment control.
4. Lights and direction indicators controls.
Headlamp wash control.
5. Instrument panel.
6. Driver's air bag.
Horn.
7. Cruise control switches.
8. Gear lever.
9. Handbrake.
10. Bonnet release.
11. Enclosed storage compartment.
Fuse box.
12. Headlamp height adjustment.
Deactivation of the ASC system.
Deactivation of the audible parking assistance.
13. Cup holder.
14. Side adjustable and closing vent.
15. Information button.
16. Window de-icing and demisting vent.
17. Windscreen de-icing vent.

INSTRUMENTS AND CONTROLS

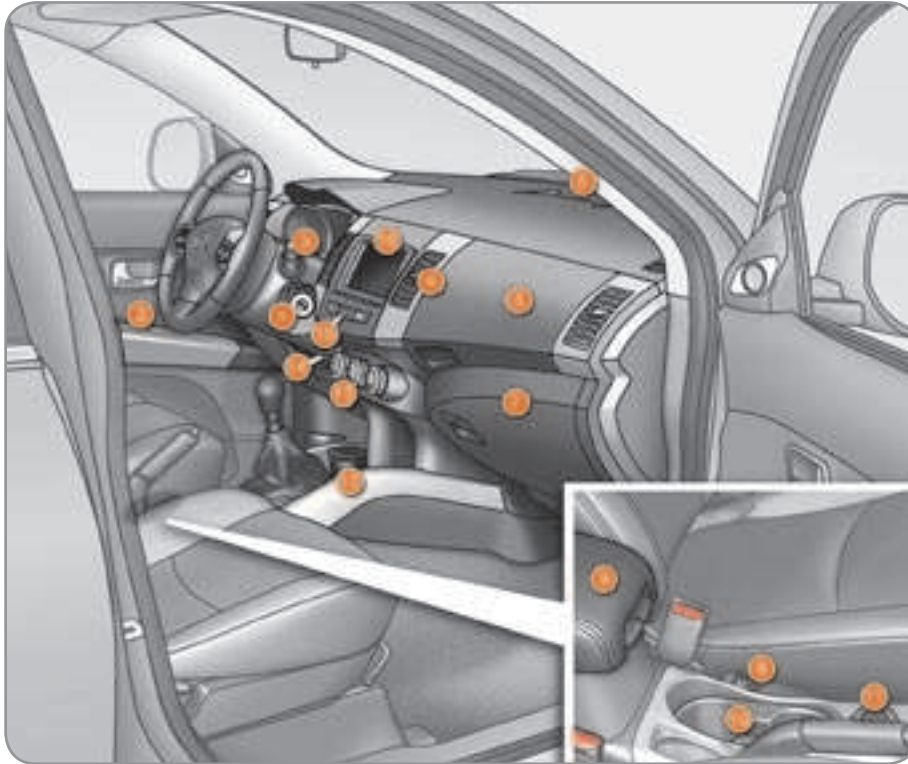

1. Steering lock and ignition.
2. Exterior mirror controls.
Electric window and rear electric window deactivation controls.
3. Front and rear wipers / wash-wipe control.
4. Central adjustable and closing vents.
5. Sunshine sensor.
6. Upper glove box with air conditioning.
7. Lower glove box with lock.
Passenger air bag disarming.
8. Heated seat controls.
9. Armrest with storage compartments.
12 volt socket (120 W max).
10. Cup holder.
11. Four wheel drive system position selector.
12. Removable ashtray / Lighter /
12 volt socket (120 W max).
13. Automatic air conditioning controls.
14. Temperature sensor.
15. Hazard warning lights switch.
16. Colour display / Audio equipment.

SITTING COMFORTABLY

Front seats

Manual adjustments



Forwards-backwards



Driver's seat cushion height and angle



Seat back angle

» 48

Electric adjustments (driver's seat only)



Forwards-backwards



Seat cushion height and angle



Seat back angle

» 49

SITTING COMFORTABLY

Manual steering wheel height adjustment



1. Unlocking of the lever.
2. Locking of the lever.
3. Adjustment of the height of the steering wheel.

» 60

Exterior mirror adjustment



- A. Selection of the mirror
- B. Adjustment of the position of the mirror.
- C. Folding / Unfolding.

» 59

Interior mirror adjustment



- D. Control for selection of the “day / night” position of the mirror.

» 60

Front seat belt



1. Fastening.
2. Height adjustment.



» 102

SITTING COMFORTABLY

Ignition switch



1. **LOCK** position.
2. **ACC** position.
3. **ON** position.
4. **START** position.

Electric window controls



1. Driver's electric window control.
2. Passenger's electric window control.
3. Rear right electric window control.
4. Rear left electric window control.

Also...

5. Deactivation of the front passenger and rear electric window controls.

Sunroof controls



1. Opening control.
2. Closing control.
3. Partial opening control.

Also...



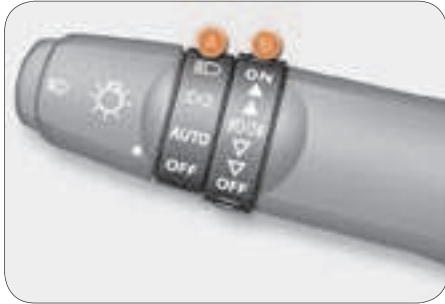

3. Also permits temporary stopping of sunroof opening / closing.

SEEING CLEARLY

Lighting



Ring A

-  Lights off.
-  Automatic switching on of the lights.
-  Side lights.
-  Dipped or main beam headlamps.





Ring B

-  Front fog lamps and rear fog lamps.

Wipers





Windscreen wipers

-  Single wipe.
-  Park.
-  Intermittent (speed which can be adjusted manually).
-  Slow.
-  Fast.



Rear wiper

-  Park.
-  Intermittent wipe.
-  Wiping with screen wash.

VENTILATING

Automatic air conditioning



Temperature adjustment.



Exterior air intake.
Interior air recirculation.



Air flow adjustment.



Automatic programme (comfort).



Deactivation of the air conditioning.



Air distribution adjustment.



Front visibility control.



Rear screen de-icing.

MONITORING

Instrument panel



- A. Speedometer.
- B. Instrument panel display.
- C. Rev counter.
- D. Fascia lighting rheostat.

» 19

Warning lights



When the ignition is on, the orange and red warning lights come on.

When the engine is running, these warning lights should switch off.

If warning lights remain on, refer to the page concerned.

» 20

Detection of fastening of the driver's seat belt



When the **ignition is switched on**, the **seat belt** warning light comes on accompanied by an audible signal if the driver has not fastened his seat belt.

The warning light switches off when the seat belt is fastened.

» 22

Controls bar



- A. Passenger air bag disarmed warning light.

» 106

- B. Hazard warning lights switch.

» 99

- C. Front passenger's seat belt not fastened or unfastened warning light.

» 103

KEEPING YOUR PASSENGERS SAFE

Front passenger air bag

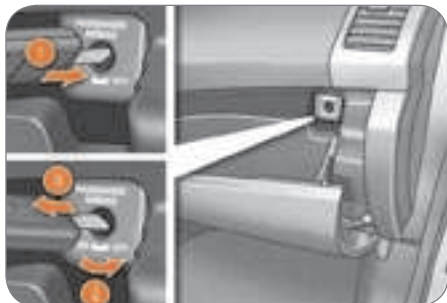

1. Insertion of the key.
2. Selection of the “OFF” position.
3. Removal of the key.

Child lock



This prevents opening of the door concerned from the inside.
Lower or raise the control **A** to lock or unlock.

Isofix mounting



Two rings **A**, located between the seat back and seat cushion of the vehicle's seat, permit the securing of a child seat.



A ring **B** permits securing of the upper strap referred to as the **TOP TETHER**.

DRIVING SAFELY

Four wheel drive system

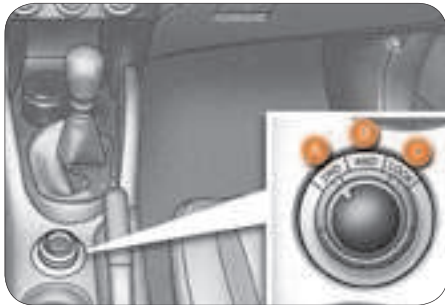

Three transmission modes are available and can be selected manually by the driver in accordance with his requirements:

- A. Two wheel drive (2WD),
- B. Four wheel drive (4WD AUTO),
- C. Four wheel drive (4WD LOCK),

Also...

You can change transmission mode when stationary or when driving at a speed below 60 mph (100 km/h).

Cruise control



This maintains a constant vehicle speed programmed by the driver.

1. **“ON/OFF”** button: activation / deactivation of the cruise control mode.
2. **“COAST SET”** button: storing of a driving speed then decreasing of the cruising speed.
3. **“ACC RES”** button: increasing of the cruising speed and recalling of the stored speed.
4. **“CANCEL”** button: switching off of the cruise control.

In order to be programmed or activated, the vehicle speed must be higher than 25 mph (40 km/h) with at least second gear engaged.

Audible rear parking assistance



This detects any obstacle (person, vehicle, tree, gate,...) located behind the vehicle.

The vehicle is fitted with four sensors:

- D. two side sensors.
- E. two central sensors.

INSTRUMENTS and CONTROLS

DIESEL MANUAL GEARBOX INSTRUMENT PANEL



Panel grouping together the dials and warning/indicator lights. These inform the driver of the activation of a system (operation or deactivation indicator lights) or of the occurrence of a fault (warning lights).







1. Speedometer.
2. Left-hand direction indicator and hazard warning lights indicator light.
3. Main beam headlamps indicator light.
4. Diesel pre-heating indicator light.
5. Side lights indicator light.
6. Front fog lamps indicator light.
7. Seat belt not fastened / unfastened warning light.
8. Rear fog lamps indicator light.
9. Anti-lock braking system (ABS) warning light.
10. Battery charge fault warning light.
11. Handbrake applied and brake fluid level warning light.
12. Cruise control mode indicator light.
13. Air bags warning light.
14. Engine management warning light.
15. Indicator light for right-hand direction indicator, Hazard warning lights indicator light.
16. Rev counter.
17. Fascia lighting rheostat.







18. Instrument panel display:
 - Warning and status displays.
 - Total and trip distance recorders.
 - Service indicator.
 - Coolant temperature.
 - Displaying of the trip computer information.
 - Cruise control reference value.
 - Fascia lighting and parameter settings.
 - Fuel level.
 - Exterior temperature.
 - Transmission mode.

INSTRUMENTS and CONTROLS

INSTRUMENT PANEL INDICATOR LIGHTS



Indicator lights	is on	Cause	Observations	
	Left-hand direction indicator	Flashing with buzzer	This flashes when you press the lights stalk down.	If this indicator light flashes abnormally quickly, this could indicate that the electric bulb of one of the direction indicators has blown. Change the bulb or contact a CITROËN dealer.
	Right-hand direction indicator	Flashing with buzzer	This flashes when you push the lights stalk up.	If this indicator light flashes abnormally quickly, this could indicate that the electric bulb of one of the direction indicators has blown. Change the bulb or contact a CITROËN dealer.
	Main beam headlamps	Fixed	This comes on when you pull the lights stalk towards you.	Pull the stalk to return to dipped headlamps.
	Side lights	Fixed	This comes on when the lights stalk is in the "Side lights" or "Dipped headlamps" position.	Turn the stalk to the position required.
	Front fog lamps	Fixed	This comes on when you use the front fog lamps.	Turn the ring on the stalk forwards to switch on the fog lamps.
	Rear fog lamps	Fixed	This comes on when you use the rear fog lamps.	Turn the ring on the stalk forwards to switch on the fog lamps.
	Cruise control	Fixed	This comes on when the mode is active.	Press the "ON/OFF" button to activate/deactivate the mode.

INSTRUMENTS and CONTROLS

Indicator lights		is on	Cause	Observations
	Diesel pre-heating	Fixed	This comes on when the ignition switch is at ON.	Wait until this light has switched off before starting. The duration for which this is displayed is determined by the exterior climatic conditions.
Warning lights		is on	Cause	Observations
	Handbrake / Brake fluid level	Fixed	This comes on for a few seconds when the ignition is turned to "ON" then switches off.	It is accompanied by a message on the instrument panel display.
			The handbrake is applied or has not been released fully.	It is accompanied by a message on the instrument panel display. Release the handbrake to switch off the warning light.
			The brake fluid level is too low.	It is accompanied by a message on the instrument panel display. Top up with brake fluid and contact a CITROËN dealer.
	Emission control system	Fixed or flashing	This comes on or flashes if the system fails.	Consult a CITROËN dealer. It should switch off a few seconds after starting the engine.
	Battery charge	Fixed	This comes on if a charging circuit fault occurs.	It should switch off when the engine is started. It is accompanied by a message on the instrument panel display. Check the battery terminals (refer to the "Battery" section).

INSTRUMENTS and CONTROLS

I

Warning lights		is on	Cause	Solution - action
	Driver's seat belt not fastened	Fixed	The driver has not fastened or has unfastened his seat belt.	This is accompanied by a message on the instrument panel display. Fasten the driver's seat belt.
	ABS	Fixed	This comes on if an anti-lock braking system failure occurs.	It is accompanied by a message on the instrument panel display. The vehicle retains conventional braking without assistance but you are advised to stop. Have it checked by a CITROËN dealer.
	Air bags and pretensioners	Fixed	This comes on for a few seconds when the ignition is turned to "ON" then switches off.	It should switch off when the engine is started. If it does not switch off, contact a CITROËN dealer.
			This comes on if an air bag or pretensioner failure occurs.	It is accompanied by a message on the instrument panel display. Have the system checked by a CITROËN dealer without delay.

INSTRUMENT PANEL DISPLAYS

Each time the engine is started: a series of warning lights and/or messages come on applying a checking self test. They switch off after a few seconds. Engine running: the warning light or the message becomes a warning if it remains on continuously or flashes. This initial warning may be accompanied by an audible signal and a message on the display. Do not ignore these warnings.

When the cause of the appearance of the warning light or warning message has been rectified, the warning disappears from the display automatically. If the cause of the warning is not rectified, you can return to the previous screen at any time by pressing the **INFO** button on the fascia.

The symbol “!” is displayed.

To return to the previous screen (with the “!” symbol), you must press the **INFO** button several times.

Symbols which appear in the top right corner of the display.

You can shut down the warning messages which show these symbols in order to move on to the next screen.

To do this, press the **INFO** button according to the symbol displayed.





Press **briefly**.













Press **and hold**.

Warning messages (ignition at “OFF”)









Message	is on	Associated warning light	Cause	Solution - action	Observations
	Fixed	-	The driver's door is open and you have forgotten to remove the key from the ignition.	Turn the ignition switch to the LOCK position and remove the key.	Only if the engine has been started. An intermittent audible signal is heard.
	Fixed	-	You have forgotten to switch off your lights.	Switch off your lights by placing the stalk at OFF.	An intermittent audible signal is heard.

INSTRUMENTS and CONTROLS

Warning messages (ignition at “ON”)







Message	is on	Associated warning light	Cause	Solution - action	Observations
	ABS	Fixed	 Anti-lock braking system (ABS) fault.	Consult a CITROËN dealer.	The vehicle retains conventional braking without assistance but you are advised to stop.
	Braking system	Fixed	 The level of brake fluid in the reservoir is too low.	Stop and top up, otherwise contact a CITROËN dealer.	If the message remains on after topping up, contact a CITROËN dealer.
			 Braking system fault.	Consult a CITROËN dealer.	It is essential to stop.
	Handbrake on	Fixed	 You have moved off with the handbrake still applied.	Release the handbrake.	
	Coolant temperature	Flashing	-	If the message flashes , wait for the engine to cool before topping up the level, if necessary.	It is essential to stop your vehicle in a safe place.
		Flashing	 High engine temperature.	If the message flashes and the service warning light comes on , contact a CITROËN dealer without delay.	
	Seat belt	Fixed	 The driver has not fastened or has unfastened his seat belt.	Fasten your seat belt.	An intermittent audible signal is heard above 5 mph (8 km/h).

INSTRUMENTS and CONTROLS



Message	is on		Cause	Solution - action	Observations
 SERVICE REQUIRED	Air bags	Fixed	 Fault in the air bags or pretensioners.	Consult a CITROËN dealer.	
 CHECK	Service	Fixed	- Problem in one of the systems which does not have a specific message.	Stop the vehicle and contact a CITROËN dealer.	To identify the problem, contact a CITROËN dealer.
 CHECK	Engine oil pressure	Fixed	- Engine oil pressure too low or fault in the oil circuit.	Stop the vehicle and contact a CITROËN dealer.	
 OIL LEVEL CHECK	Engine oil level	Fixed	- Engine oil level too low.	Stop the vehicle and check the level using the dipstick.	If there is a lack of oil, top up the level.
 REFUEL	Fuel level warning	Fixed	- The fuel tank level is low.	Fill your fuel tank as soon as possible.	
 SERVICE REQUIRED	Fuel circuit	Fixed	- Fuel circuit fault.	Consult a CITROËN dealer.	
	Accessories not closed correctly	Fixed	- One of the doors or the tailgate is not closed correctly.	Close the door or the tailgate.	The access concerned is indicated on the display.

INSTRUMENTS and CONTROLS

I

Message		is on	Associated warning light	Cause	Solution - action	Observations
	Dynamic stability control system (ASC)	Fixed	-	Dynamic stability control system (ASC) fault.	Consult a CITROËN dealer.	
	Four wheel drive system	Fixed	-	Four wheel drive transmission system fault.	Consult a CITROËN dealer.	
	Four wheel drive system temperature	Fixed	-	The temperature of the four wheel drive transmission system is too high.	Stop the vehicle and contact a CITROËN dealer.	The vehicle switches to front wheel drive (2 WD) mode automatically.
	Automatic headlamp adjustment system	Fixed	-	The automatic headlamp adjustment is faulty.	Consult a CITROËN dealer.	Only on vehicle fitted with xenon bulbs.
	Battery charge	Fixed		Battery charge fault.	Stop the vehicle and contact a CITROËN dealer.	
	Exterior temperature	Fixed	-	The exterior temperature 3 °C (37 °F) or below.	Road icy. Pay attention and drive slowly.	Caution: The road may be icy even when this screen is not displayed.





INSTRUMENTS and CONTROLS

Message		is on	Associated warning light	Cause	Solution - action	Observations
	Saturation of the particle emission filter	Fixed	-	Start of saturation of the particle emission filter.	As soon as traffic conditions permit, regenerate the filter by driving at a speed of at least 35 mph (60 km/h) until the message is cleared.	If the message is still displayed, contact a CITROËN dealer.
	Diesel additive level	Fixed	-	Low diesel additive level.	Have the level topped up by a CITROËN dealer without delay.	
	Water in the diesel filter (according to country)	Fixed	-	The presence of water in the diesel filter is indicated. Risk of damage to the injection system on Diesel engines.	Contact a CITROËN dealer without delay.	



I

INSTRUMENTS and CONTROLS

Information messages (ignition at “ON”)

Message	is on	Status of the system
 2WD two wheel drive system	Flashing	When the “2WD” (2 wheel drive) mode is selected using the transmission mode selector.
 4WD four wheel drive system	Flashing	When the “4WD” (4 wheel drive) mode is selected using the transmission mode selector. This mode is the default mode.
 4WD LOCK four wheel drive system	Flashing	When the “LOCK” (4 wheel drive) mode is selected using the transmission mode selector.
 Dynamic stability control system (ASC)	Fixed	When the dynamic stability control system (ASC) is active.
 Exterior temperature	Fixed	This indicates the exterior temperature. When the vehicle is stationary or if the speed is below 12 mph (20 km/h) the temperature displayed may not correspond to the exterior temperature.

Prevention messages

Display	is on	Cause	Solution - action	Observations
 Service indicator	Fixed	Informs the driver of the time remaining before the vehicle’s scheduled service.	Consult a CITROËN dealer.	This is displayed for a few seconds when the ignition is switched on.
 Break advised	Fixed	Informs the driver that he should stop to take a break.	You are advised to take a break.	This is displayed when the driving time that you set previously is reached. An audible signal is heard 3 times and is then heard every 5 minutes until the vehicle stops.

INFORMATION ON THE INSTRUMENT PANEL DISPLAY

Data displays



With the ignition on, press the **INFO** button, located on the fascia to the left of the instrument panel, to display the various information displays in succession:

- the distance recorder A,
- the distance recorder B,
- the service indicator,
- the coolant temperature,
- the range,
- the trip computer,
- the setting menu.

Distance recorder (A and B)



The total distance is displayed in zone 1 of the display and the trip distance in zone 2 (refer to the "Distance recorders" section).

Service indicator



This displays the distance and the number of months remaining before the next service to be carried out in accordance with the manufacturer's servicing schedule (refer to the "Service indicator" section).

Coolant temperature



When the engine is running, this indicates the temperature of the coolant (refer to the "Coolant temperature indicator" section).

Range



When the engine is running, this indicates the number of miles (kilometres) which can still be travelled with the fuel remaining in the tank in relation to the average consumption over the last few miles (kilometres) travelled (refer to the "Range" section).

Trip computer

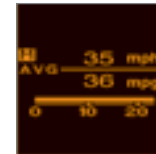

This indicates the average consumption, the average speed and the current consumption (refer to the "Trip computer" section).

Setting menu



When the vehicle is stationary, this allows the user to change the following parameters (refer to the "Function parameters" section):

- the display language,
- the temperature display unit,
- the fuel consumption unit,
- the option to reinitialise the average consumption and the average speed,
- the break (rest) reminder display interval.

DISTANCE RECORDERS (A / B)

System for measuring the total distance travelled by the vehicle during its service life and the distance travelled in a day or other period until it is reset to zero by the driver.



The total distance is displayed in zone 1 of the display and the trip distance in zone 2.

Zero reset

With the ignition on, press the **INFO** button for more than 2 seconds until zeros appear.

COOLANT TEMPERATURE



When the engine is running, this indicates the temperature of the coolant.

If the bar is close to the **critical** position located on the right, the temperature is too high.

The symbol flashes when your engine is overheating.

It is imperative that you stop your vehicle safely.

Wait a few minutes before switching off the engine.



Wait for the engine to cool before topping up the level. The cooling system is pressurised.

As the cooling system is pressurised, to avoid any risk of scalding, unscrew the cap by two turns to allow the pressure to drop.

When the pressure has dropped, remove the cap and top up the level, if necessary.

Consult a CITROËN dealer.

RANGE



When the engine is running, this indicates the distance which can still be travelled with the fuel remaining in the tank in relation to the average consumption over the last few miles/kilometres travelled.

When the range is less than **30 miles** (50 km), dashes are displayed.

Fill the fuel tank as soon as possible. The display of the range is updated.

This figure may increase following a change in the style of driving or the relief, resulting in a reduction in the current consumption.

If you only add a few litres, the value displayed will be incorrect. Therefore, you must fill the tank whenever possible.



When you disconnect the battery, the previous consumption data is lost and the value displayed will be different from that displayed before the battery was disconnected. The distance displayed must be considered an approximate indication.

SERVICE INDICATOR

System which informs the driver when the next service is due in accordance with the manufacturer's servicing schedule.

The point at which the next service is due is calculated from the last service indicator zero reset.

It is determined by two parameters:

- the distance travelled (in miles (km)),
- the time elapsed since the last service (in months).

The distance remaining to be travelled may be weighted by the time factor, depending on the user's driving habits.

Operation

When the ignition is switched on, you must press the **INFO** button several times in succession until the service indicator is displayed. The distance recorder display line indicates the number of miles (kilometres) remaining and the time elapsed line indicates the number of months remaining before the next service is due.

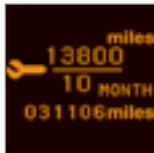

Example: the display indicates that 7300 miles (kilometres) remain before the next service is due.



The symbol “---” remains displayed until the first service of a new vehicle has been carried out.

Service overdue

Each time the ignition is switched on, the display “**SCHEDULED SERVICE**” is displayed for a few seconds to indicate that the service must be carried out without delay.



Example: the display indicates that the service is overdue. This service must be carried out by a CITROËN dealer.



Resetting the service indicator to zero

Your CITROËN dealer carries out this operation after each service.

If you have carried out your vehicle's service yourself, the zero reset procedure is the following:

- ☞ switch off the ignition,
- ☞ press the **INFO** button several times in succession until the service indicator is displayed.
- ☞ press and hold the **INFO** button for a few seconds until the **spanner flashes**.
- ☞ press the **INFO** button while the spanner is flashing to change the display “---” to “**CLEAR**” then the time remaining before the next service is due is displayed.



After a certain distance and a certain time, the displaying of “---” is reinitialised and the display indicates the time remaining before the next service is due.

TRIP COMPUTER

System which provides current information about the route travelled.

Data displays



With the ignition on, press the **INFO** button on the fascia, to the left of the instrument panel, several times in succession to display the different information:

- the average consumption,
- the average speed,
- the current consumption.

If dashes “---” are displayed for long periods in place of the digits while driving, contact a CITROËN dealer.



Average consumption (l/100km or km/l or mpg)

This is the average quantity of fuel consumed since the last zero reset.

This figure may increase following a change in the style of driving or the relief resulting in a reduction in the current consumption.



Average speed (km/h or mph)

This is the average speed calculated since the last zero reset.



Current consumption (l/100km or km/l or mpg)

This is the average quantity of fuel consumed during the last few seconds of driving.

Resetting the information to zero



When the required information is displayed, press the **INFO** button for more than two seconds.

When the ignition is switched on, the zero reset switches automatically from manual mode to automatic mode.

Automatic

If the ignition remains in the “**ACC**” (Accessories) position for at least 4 hours, the average consumption value is reset to zero automatically.

FUNCTION PARAMETERS

System which provides access to certain function parameters.

With the ignition on, press the **INFO** button on the fascia, to the left of the instrument panel, several times in succession until the "SETTING MENU" screen is displayed.



When the vehicle is stationary, it allows the user to change the following parameters:

- the choice of the reinitialisation of the average consumption and average speed,
- the fuel consumption unit,
- the temperature display unit,
- the display language,
- activation/deactivation of the **INFO** button sound,
- the break (rest) reminder display interval,
- restore the manufacturer's parameters.



In order to change the settings, it is essential that you stop the vehicle and switch on the ignition.

Apply the handbrake and place the gear lever in neutral.

When the vehicle is moving, the functions setting display is not displayed when you press the **INFO** button.

Operation

- ☞ press and hold the **INFO** button for a few seconds to display the menus screen.



- ☞ on the menus screen, press the **INFO** button to select a function from the list:

MENU 1/2:

- **1 - 2** (choice of the reinitialisation of the average consumption and average speed),
- **UNIT** (choice of the fuel consumption units),
- choice of the **temperature display unit**,
- **LANGUAGE** (choice of the display language),

MENU 2/2:

- **a/b** (choice of displaying a different language on the instrument panel display and the navigation display),
- **activation / deactivation** of the **INFO** button sound,
- **ALERT** (changing of the "BREAK ADVISED" break reminder display interval),
- **REINITIALISE** (restore the manufacturer's parameters).

Press and hold the **INFO** button for a few seconds to return to the previous screen.

When the menus screen is displayed, if no operation is carried out within 15 seconds, the function parameters screen is displayed.

Choice of the reinitialisation of the average consumption and average speed

You can choose between two average consumption and average speed reinitialisation modes:

- automatic reinitialisation (**choice 1**),
- manual reinitialisation (**choice 2**).

On the menus screen:

- ☞ press the **INFO** button to select:



- ☞ press and hold the **INFO** button for a few seconds to switch in succession from reinitialisation **mode 1 (automatic)** to reinitialisation **mode 2 (manual)**.

The mode selected is confirmed.

Choice of the fuel consumption units

You can choose between different units for displaying the fuel consumption.

In this case, the distance, speed and quantity of fuel units will also be changed in accordance with your choice of fuel consumption unit.

On the menu screen:

- ☞ press the **INFO** button to select “UNIT”.

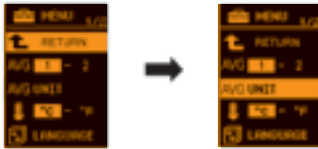

- ☞ press and hold the **INFO** button for a few seconds to display the “UNIT” screen.



- ☞ press the **INFO** button to scroll the units (km/L, L/100km, mpg(US), mpg(UK) and PREVIOUS) in succession.
- ☞ press and hold the **INFO** button for a few seconds to confirm your selection.

If the battery is disconnected, the parameter memory is cleared and the default unit (km/L) is restored automatically.

Choice of the temperature display unit

You can choose between different units for displaying the temperature.

On the menu screen:



- ☞ press the **INFO** button to select the temperature unit parameters symbol (thermometer).

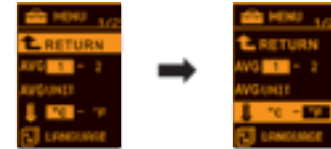

- ☞ press and hold the **INFO** button for a few seconds to scroll the units (°C and °F) in succession.

The mode selected is confirmed.

If the battery is disconnected, the parameter memory is cleared and the default unit (°C) is restored automatically.

Choice of the display language (LANGUAGE)

You can choose between different languages for the display.

On the menu screen:

- ☞ press the **INFO** button to select “LANGUAGE”.

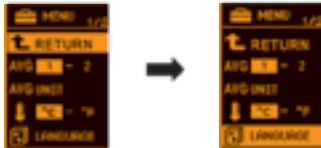

- ☞ press and hold the **INFO** button for a few seconds to display the “LANGUAGE” screen.



- ☞ press the **INFO** button to scroll the languages (Japonais, English, Deutsch, Français, Espanol, Italiano, “---” and PREVIOUS) in succession.

- ☞ press and hold the **INFO** button for a few seconds to confirm your selection.

If you select the parameter “---”, no message will be displayed in message display situations.

If the battery is disconnected, the parameter memory is cleared and the default language (ENGLISH) is restored automatically.

Activation / deactivation of the “INFO” button sound

You can activate or deactivate the **INFO** button sound.

On the menu screen:



- ☞ press the **INFO** button to select the **INFO** button sound activation / deactivation symbol (located on menu 2/2).



- ☞ press and hold the **INFO** button for a few seconds to scroll the choices (ON, OFF) in succession.

The mode selected is confirmed.

If the battery is disconnected, the parameter memory is cleared and the default choice (ON) is restored automatically.

Changing the display interval of the “BREAK ADVISED” message

You can change the display interval of the “BREAK ADVISED” message.

On the menu screen:

- ☞ press the **INFO** button to select “ALERT” (located on menu 2/2).



- ☞ press and hold the **INFO** button for a few seconds to display the “ALERT” screen.



- ☞ press the **INFO** button to select the display interval of the “BREAK ADVISED” message.

- ☞ press and hold the **INFO** button for a few seconds to confirm.

If the battery is disconnected, the parameter memory is cleared and the default value (OFF) is restored automatically.

Restoring the manufacturer's parameters (REINITIALISE)

You can restore all of the manufacturer's settings for all of the functions.

On the menu screen:

- press the **INFO** button to select "**REINITIALISE**" (located on menu 2/2).



- press and hold the **INFO** button for **at least 5 seconds**.

An audible signal is heard and all of the manufacturer's settings are restored for all of the functions.

The manufacturer's settings are:

Functions	Manufacturer's setting
Reinitialisation of the average consumption and average speed	1 (automatic)
Fuel consumption units	L/100 km
Temperature display unit	°C
Display language	ENGLISH
INFO button sound	ON (activated)
Displaying of the "BREAK ADVISED" message	OFF (deactivated)

LIGHTING RHEOSTAT

System for manual adjustment of the brightness of the instruments and controls in relation to the exterior brightness.



With the lights on or off, press the button to change the intensity of the lighting of the instruments and controls in "day" or "night" mode.

An audible signal is heard and the intensity of the lighting increases each time the button is pressed.

When the lighting reaches the maximum setting, press again to change to the minimum setting.

When the lighting reaches the required intensity, release the button.

The setting is saved when the ignition switch is turned to OFF.

MONOCHROME DISPLAY



This provides the following information:

- the time,
- the audio equipment displays (refer to the “Audio and Telematics” section).

Setting the time



The digital clock can be set in **automatic mode** or in **manual mode**.

Automatic mode

This mode permits automatic setting of the local time using the signal from the RDS stations.

The symbol “CT” appears on the display.

Manual mode

This mode permits manual setting of the time using the audio equipment buttons.

It can also be used when the “Automatic mode” displays an inaccurate time, when the local RDS stations are broadcasting from a different time zone.

Selecting the Setting

Select the **automatic mode** or the **manual mode** as follows:

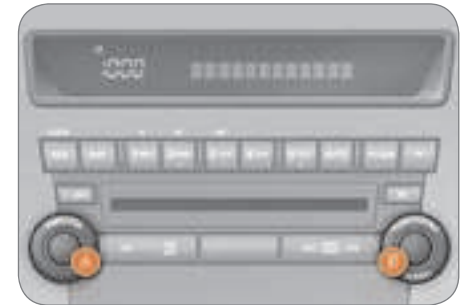

- ☞ Press button **A** “PWR” to switch on the audio system.
- ☞ Access the setting mode by pressing button **B** “TUNE” for approximately 2 seconds.
- ☞ Press button **B** “TUNE” several times to scroll through the various menus and select the **CT menu** (clock time).

The order of the menus is the following: AF / CT / REG / TP-S / PTY display language / SCV / PHONE / Functions setting mode OFF.



- ☞ Turn button **B** “TUNE” to the left or to the right to select “**CT ON**” (automatic mode) or “**CT OFF**” (manual mode).
- ☞ After selecting the mode, you can exit the “Functions setting mode” menu by pressing button **B** “TUNE” for approximately 2 seconds.

If no action is carried out within 10 seconds, the system will exit the “functions setting mode” menu automatically.

Automatic mode

In this mode, setting is automatic using the signal from the RDS radio stations.

Manual mode



Set the time using the buttons as indicated below:

- ☞ with the ignition on or in the ACC (Accessories) position, press and hold the **CLOCK** button until the time display flashes.
- ☞ Press the appropriate button to set the time:

Button H: setting of the hour

The hours digits scroll when you press this button.

Button M: setting of the minutes

The minutes digits scroll when you press this button.

Button :00: resetting of the minutes to zero.

- from **1 to 29 min:** rounded down to the previous hour,
- from **30 to 59 min:** rounded up to the next hour.

- ☞ After setting the time, press the **DISP** button; the time display stops flashing.

The digital clock does not display seconds.

When the “minutes” display is set or reset to zero, the clock starts at the zero second of the minute selected.

The time setting is lost if the battery is disconnected.

INSTRUMENTS and CONTROLS

COLOUR DISPLAY



This permits displaying of the following main menus:

“Audio-video” menu

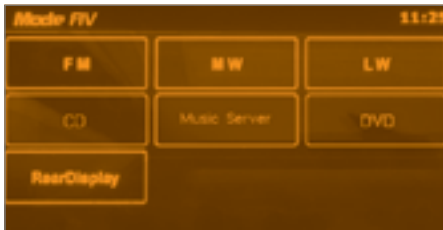

On the control panel, press button **A (MODE)** to access the “**AV mode**” screen and select:

- the radio (FM, MW, LW),
- the CD (audio, MP3 or WMA),
- the Music Server,
- the DVD,
- the Auxiliary (Rear Display).

The “CD” and “DVD” buttons are active if you insert a CD or DVD in the player.

“Settings” menu

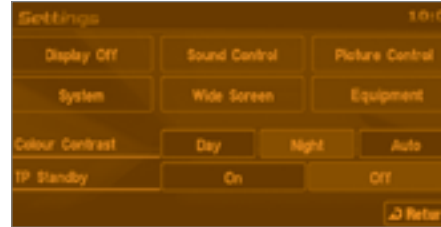

On the control panel, press button **B (SET)** to access the “**Settings**” screen and select:

- “**Display Deactivated**” to switch off the display,
- “**Sound control**” for the sound distribution or volume, the type of music and the sound field (surround),
- “**Picture control**” to set the colour, the intensity, the brightness, the contrast and the level of black,
- “**System**” to change the time zone, the language, the units and other settings,
- “**Wide Screen**” to change the size of the DVD picture to 4/3 format, wide screen mode, centred wide screen mode or enlargement,
- “**Equipment**” to set certain equipment offered in the vehicle,
- “**Col Contrast**” to select the contrast of the display in relation to the exterior light (Day, Night or Auto),
- “**TP standby**” to activate or deactivate the traffic information.

“Navigation-guidance” menu



On the control panel, press button **C (MENU)** to access the “**Menu**” screen and select:

- “**Address/Junction**” to search for a location using the address or the name of the street,
- “**POI name**” to search for a location using the name of a point of interest (POI),
- “**Advanced search**” to search for a location using an advanced search based on a POI,
- “**20 Previous**” to search for a location using one of the 20 previous destinations,
- “**Address book**” to search for a location using a stored address,
- “**Return to the initial screen**” to enter a return home,
- “**Navigation settings**” to set functions linked with the navigation,
- “**Navigation tools**” to access the basic information or a pre-set demonstration.

INSTRUMENTS and CONTROLS

“Information” menu

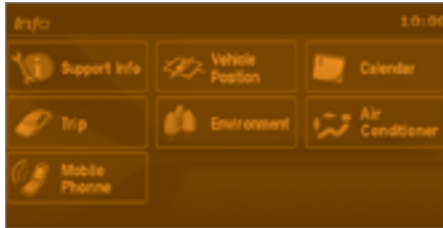

On the control panel, press button **D (INFO)** to access the “Info” screen and consult:

- “**Support info**” to display the software and data versions,
- “**Vehicle position**” to display the GPS location of the vehicle,
- “**Calendar**” to make a note of events, birthdays, etc.,
- “**Journey**” to display the average speed, the consumption, the distances and the duration of driving,
- “**Environment**” to display the altitude, the atmospheric pressure, the exterior temperature (the ice symbol is displayed if there is a risk of ice),
- “**Air conditioning**” to display the information relating to the air conditioning,
- “**Mobile telephone**” to enter a number, delete a character, make or receive a call.

“Map” menu

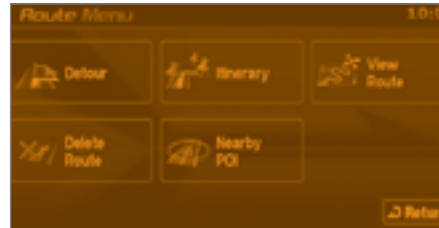

On the control panel, press button **E (NAVI)** to access the “Routes Menu” screen and select:

- “**Detour**” to make a detour through a specified region,
- “**Route**” to change the route,
- “**Display a route**” to display a route in different ways,
- “**Delete a route**” to delete a route,
- “**Local POI**” to search for the POIs in the surrounding area.

Setting the time



The digital clock is set **automatically**.

This mode enables the system to set the local time automatically using the signal from the RDS stations.

☞ On the control panel, press button **A (SET)** to access the “Settings” menu.

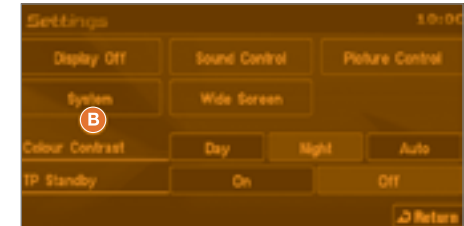

☞ On the touch screen, press button **B** to access the “System” menu.

The system settings screen is displayed.

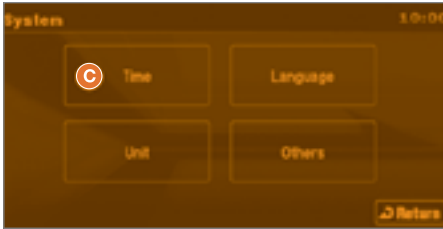

☞ Press button **C** to access the “**Time**” menu.

Once this menu has been selected, you can access the following functions:

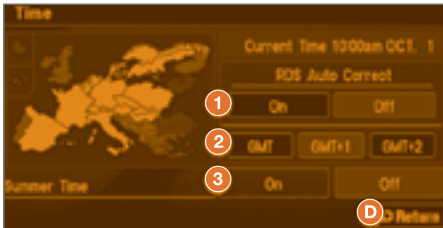

1. RDS Auto Correction:

Activate / deactivate the automatic adjustment.

2. GMT / GMT+1 / GMT+2

Select the time zone.

3. Summer Time:

Activate / deactivate summer time.

☞ Press button **D** to confirm and return to the previous menu.

It is essential to deactivate the automatic adjustment (RDS Auto Correction) in order to be able to change the time zone and summer time.

On each screen, you can return to the previous screen by pressing button **D** “**Return**”.

VIDEO MENU



You can connect video equipment (camcorder, digital camera,...) to the three video sockets located on the back of the front central armrest.

Video sources can only be displayed when stationary.

Select the “**AV Mode**” menu by pressing the “**MODE**” button on the control panel.

From the “**AV MODE**” menu on the touch screen, press:

- the “**RearDisplay**” button to access the Auxiliary menu,
- the “**Video parameters**” button to set the display format, the brightness, the contrast and the colours.

Press the “**Back**” button to exit video mode.

AUTOMATIC REGULATION OF THE AIR CONDITIONING

II

Use of the automatic regulation of the air conditioning is recommended. It permits automatic and optimised control of all of the following functions: air flow, passenger compartment temperature and air distribution, by means of various sensors (exterior temperature, interior temperature, sunshine), so preventing the need for you to change your reference settings other than the value displayed.

Do not cover the temperature and humidity sensor **2** and the sunshine sensor **7**.

They are required for regulation of the air conditioning.

Advice on operation

In hot weather, in order to obtain intense ventilation, it is advisable to use vents **1** and **4** only.

If, when the vehicle has been parked in the sun for a long time, the interior temperature remains very high, do not hesitate to ventilate the passenger compartment for a few minutes.

For even air distribution, take care not to obstruct the exterior air intake grille located at the bottom of the windscreen, the vents, the air outlets under the front seats and the air extractor located behind the flaps in the boot.

In certain cases of particularly arduous use (towing the maximum load on a steep gradient in hot weather), cutting off the air conditioning permits recovery of the engine power and therefore improvement of the towing capacity.

Close the windows to benefit from the full effectiveness of the air conditioning.

Ensure that the passenger compartment filter is in good condition. Have the filter elements replaced periodically. If you drive in a dusty environment, replace it twice as often.

The air conditioning system does not contain chlorine and is not harmful to the ozone layer.

Operate the air conditioning system for 5 to 10 minutes, once or twice a month, to keep it in perfect working order.

The water formed by the air conditioning condensation is discharged via an opening provided for this purpose. Therefore, a puddle of water may form underneath the vehicle when stationary.

If the system does not produce cold air, do not use it and have it checked by a CITROËN dealer.

1. Centre panel vents.
2. Temperature sensor.
3. Air outlet to passenger footwells.
4. Side vents.
5. Front windows de-icing or demisting vents.
6. Windscreen de-icing or demisting vents.
7. Sunshine sensor.

Switch off the air conditioning when the climatic conditions permit.

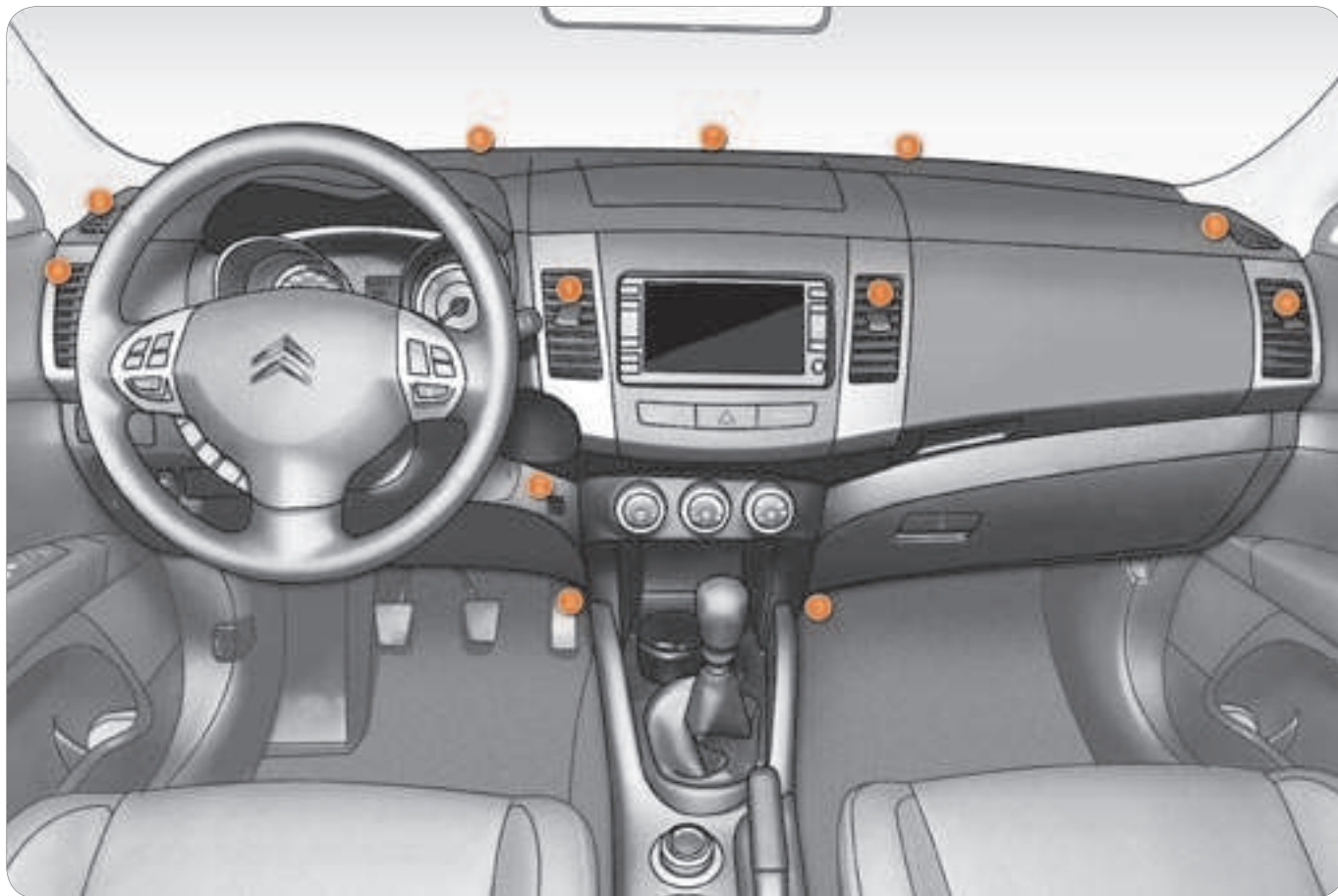

AUTOMATIC AIR CONDITIONING

II

1. Temperature adjustment
2. Air flow adjustment
3. Air distribution adjustment
4. Intake of exterior air / Recirculation of interior air
5. Air conditioning On / Off
6. Rear screen de-icing



Automatic operation

- ☞ Set the temperature control dial **1** to the temperature required.
- ☞ Place the air flow control dial **2** in the “**AUTO**” position.
- ☞ Place the air distribution adjustment dial **3** in the “**AUTO**” position.

In accordance with the level of comfort selected, the system controls the air distribution, the flow, the temperature and the air intake to guarantee comfort and a sufficient circulation of air in the passenger compartment. No further action on your part is required.

In automatic mode:

- ☞ when the temperature is set to maximum (Rapid heating), the intake of exterior air is activated and the air conditioning stops.
- ☞ when the temperature is set to minimum (Rapid cooling), the air recirculation is activated and the air conditioning operates.

When the engine is cold, to avoid an excessive distribution of cold air, the ventilation will reach its optimum level gradually.

On entering the vehicle, the interior temperature may be much colder (or warmer) than the comfort temperature. There is no need to change the temperature displayed in order to reach the comfort required rapidly.

The automatic regulation of the air conditioning will operate at maximum performance to eliminate the temperature difference as quickly as possible.

Manual operation

It is possible to set one or more functions manually while leaving the other functions in automatic mode.

Switching to manual mode may result in discomfort (temperature, humidity, odour, condensation) and does not offer optimum comfort.

Temperature adjustment (1)



☞ Turn the temperature control dial to the right to increase the temperature and to the left to decrease it.

Air flow adjustment (2)



☞ Turn the dial to the right to increase the air flow or to the left to decrease it.

To avoid condensation and deterioration of the quality of the air in the passenger compartment, ensure that a sufficient flow of air is maintained.

Air distribution adjustment (3)



☞ Place the dial in the position required to direct the air towards:



the central and side vents,



the central and side vents and the footwells,



the footwells,



the windscreen, the side windows and the footwells,



the windscreen and the side windows.

The air distribution can be adapted by placing the adjustment dial in the intermediate positions.





Intake of exterior air / Recirculation of interior air (4)

This function insulates the passenger compartment from exterior odours and smoke.

☞ Press button **4** to select the air intake mode.

When the indicator light on button **4** is off, the exterior air intake function is activated.

When the indicator light on button **4** is on, the intake of exterior air is deactivated and the system is in air recirculation mode.

Do not drive for long periods in interior air recirculation mode, except in truly exceptional atmospheric conditions.

Personalisation of the Exterior air intake / Interior air recirculation function

This function is controlled automatically. However, you can deactivate its automatic control if you wish to change the air intake mode at any time.

Changing the status

Press the Air intake / Interior air recirculation button for at least 10 seconds.

When the status changes from active to inactive, three beeps are heard and the indicator light flashes three times.

When the status changes from inactive to active, two beeps are heard and the indicator light flashes three times.

Automatic control active

If the air distribution adjustment dial and the air flow adjustment dial are placed in the "AUTO" position, the Air intake / Interior air recirculation function is also controlled automatically.

Automatic control inactive

Even if the air distribution adjustment dial and the air flow adjustment dial are placed in the "AUTO" position, the Air intake / Interior air recirculation function is no longer controlled automatically.

The settings are retained, even after switching off the ignition.



Air conditioning On / Off (5)

☞ Press button **5** to activate the air conditioning.

The indicator light comes on.

Personalisation of the Air Conditioning On / Off function

This function is controlled automatically. However, you can deactivate its automatic control if you wish to activate or deactivate the air conditioning at any time.

Changing the status

Press the Air Conditioning On / Off button for at least 10 seconds.

When the status changes from active to inactive, three beeps are heard and the indicator light flashes three times.

When the status changes from inactive to active, two beeps are heard and the indicator light flashes three times.

Automatic control active

If the air distribution adjustment dial and the air flow adjustment dial are placed in the "AUTO" position, or if the temperature control dial is set to the minimum temperature, the air conditioning system is controlled automatically.

Automatic control inactive

The air conditioning system is no longer controlled automatically.



Rear screen de-icing (6)

With the engine running, press button **6** to activate the de-icing of the rear screen and exterior mirrors.

The indicator light on the button comes on while the de-icing is in operation.

The de-icing switches off automatically to prevent an excessive consumption of current.

The operation of the de-icing can be stopped before it is switched off automatically by pressing the button again.

It is advisable to switch off the rear screen de-icing as soon as possible as lower current consumption reduces the fuel consumption.

Windows and windscreen de-icing



De-icing

1. Press button **A** to select "exterior air intake". The indicator light on this button is switched off.
2. Place the air distribution dial in the "windscreen, side windows and footwells" position.
3. Select the air flow required.
4. Select the temperature required.
5. Press the "air conditioning on / off" button **B** to activate the air conditioning. The indicator light on this button comes on.



Rapid de-icing

1. Place the air distribution dial in the "windscreen and side windows" position.
2. Select the maximum air flow.
3. Select the maximum temperature.

FRONT SEATS

Seat consisting of a seat cushion, seat back and head restraint which can all be adjusted to your optimum driving and comfort position.

Manual mode



Forwards-backwards adjustment

Raise the control bar and slide the seat forwards or backwards.

When your seat is at the correct distance, move it forwards and backwards slightly without using the control bar to check that it is secured correctly.



Driver's seat cushion height and angle adjustment

Pull and/or push the control several times to adjust the height of the seat.



Seat back angle adjustment

Pull the control upwards to adjust the seat back.

When the seat back is at the correct angle, release the control.



To prevent the seat back from moving forward sharply and knocking you, press on it with your back or push it with your hand while operating the lever.

FRONT SEATS

Seat consisting of a seat cushion, seat back and head restraint which can all be adjusted to your optimum driving and comfort position.

Electric mode (driver's seat only)



Forwards-backwards adjustment

Push the control forwards or rearwards to move the seat to the position required.



Driver's seat cushion height and angle adjustment

Pull or push the front of the control to raise or lower the front of the seat cushion.

Pull or push the rear of the control to raise or lower the rear of the seat cushion.

Pull or push the entire control to raise or lower the entire seat cushion.



Seat back angle adjustment

Tilt the control forwards or rearwards to straighten or tilt the seat back.

To avoid discharging the battery, use the electric mode with the engine running.

Heated seats adjustment



With the **engine running**, tilt the button to the position required.

The temperature of the seat is regulated automatically.

There are two setting positions:

- “HI”: High heating
- “LO”: Low heating

When the button is in the intermediate position, the heating is switched off.

The indicator lights **A** comes on when the system is activated.

Head restraint height adjustment



To raise the head restraint, pull it upwards.

To lower the head restraint, push it downwards pressing the height adjustment button at the same time.

To remove the head restraint, bring it to the uppermost position then remove it pressing the height adjustment button at the same time.

To refit the head restraint, engage the stems of the head restraint in the holes pressing the height adjustment button at the same time.

! Never drive with the removed head restraints in the vehicle as they could be thrown around the vehicle on sharp braking. They must be in place and adjusted correctly.

After installing the head restraint, check that the height adjustment button is locked correctly.

The adjustment is correct when the top of the head restraint is aligned with the top of the head of the seated person.

Front armrest



You can move the console housing cover in order to use it as an armrest.

REAR SEATS (ROW 2)

The rear seats can be folded in two parts (1/3 - 2/3).



Forwards-backwards adjustment

Pull the control towards the outside and adjust.

When your seat is at the correct distance, release the control.

To ensure that the seat is secured correctly, move it forwards and backwards slightly without using the control.



Seat back angle adjustment

Pull the control and adjust.

When the seat back is at the correct angle, release the control.

Sit in the centre of the rear bench seat to check that the two seats are at the same level and that the angle of their seat backs is the same.



When manoeuvring the seats, ensure that no person or object is in the vicinity of the moving parts to avoid any risk of injury or damage.

To prevent the seat back from moving forwards sharply and knocking you, press on it with your back or push it with your hand while operating the lever.

Rear armrest

Access to the third row

II



Lower the armrest to use it.
To return to the initial configuration,
push the armrest until it locks in its vertical
position.



The passenger gains access to the
third row of seats by tilting a second
row seat.

To put this seat back in place, refer to
the following pages.

Folding the second row

Before folding the seats, lower the head restraints fully.

Before folding the seat backs forwards, insert the seat belt buckles in the slots provided for this purpose in the rear seat cushion.

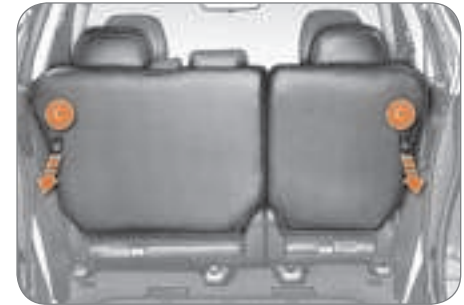

1. Raise the rear seat lever **A**, or Pull the button in the boot **B** for at least one second, or Pull the rear seat releasing strap **C** towards you.
2. The seat backs fold forwards then the cushion rises and folds forwards.
3. After carrying out these operations, press on the seat lightly to check that it is secured correctly.



Before folding the seats, ensure that no object or person is hindering the execution of the operations.
Do not place luggage on the folded seats.

Returning the second row to the normal position

II



1. Lower the seat pulling simultaneously on the releasing strap **A** located at the rear of the cushion and supporting the seat with your hand.



2. Press on the cushion to put it in place until it engages.



3. Pull the seat back upright pulling simultaneously on the releasing strap located at the rear of the seat back.
4. After putting the seat back back in place, push the seat and the seat back lightly to ensure that they are secured correctly.

Force may be necessary to carry out these operations.

On vehicles fitted with a third row, the rear of the cushion of the second row is fitted with a low light **B**.

When the releasing strap is pulled, the light comes on for approximately 10 seconds to light the floor at the base of the third row.

“Lowered seats” configuration

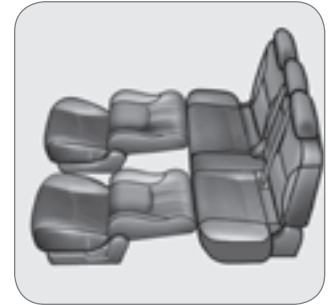

1. Remove the head restraints from the front seats.
2. Raise the rear armrest and remove the load space cover.
3. Move the rear seats as far back as possible.
4. Move the front seats as far forward as possible and tilt their seat backs fully.
5. Tilt the seat back of the rear seats.

To return the seats to their normal position, carry out these operations in reverse order.

REAR BENCH SEAT (ROW 3)

II



The rear bench seat can be folded. It retracts into a location in the floor of the vehicle.

For comfort, it is advisable to fold the bench seat when it is not in use.



The label on the bench seat back illustrates the various steps to be followed when unfolding and folding the rear bench seat.

Unfolding the bench seat



1. Open the tailgate and the lower tailgate (refer to the "Access section").
2. Pull the cover **A** from the rear and fix it to the seat back using the press stud of the band **B**.

COMFORT

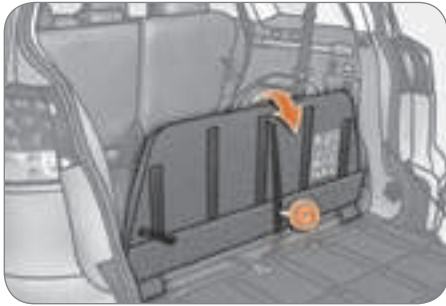

3. Pull the black strap **C** located at the centre of the seat back to raise the seat back.



4. Pull the black strap **D** to release the bench seat cushion.



5. Tilt the bench seat rearwards.



6. Raise the head restraints.



7. Lift and push the bench seat assembly forwards until it locks.

Undo the press stud of band **B** to release the cover.

Folding the bench seat

II



1. Open the tailgate and the lower tailgate (refer to the "Access" section).
2. Lift the cover **A** and fix it to the seat back using the press stud of the band **B**.



3. Unlock the head restraints by sliding the controls **C** and fold them onto the seat back.



4. Pull the grey strap **D** and bring the bench seat towards you. Press on the bench seat to lock it.



5. Tilt and push the bench seat forwards.



6. Pull the black strap **E** located at the centre of the seat back to fold the seat back.

Undo the press stud of the band **B** to put the cover back in place.

EXTERIOR MIRRORS

**Adjustment**

The mirrors can be adjusted when the ignition switch is in the “ON” or “ACC” position.

- ☞ Move control **A** to the right or to the left to select the corresponding mirror.
- ☞ Direct control **B** in all four directions to adjust the mirror.

When adjustment is complete, return control **A** to the central position.

**Electric folding / unfolding**

- from inside, with the ignition switch in the “ON” or “ACC” position
 - ☞ by pressing the control **C**.
- from inside, with the ignition switch in the “LOCK” position:
 - ☞ by pressing the control **C**, **within 30 seconds**.
- from outside using the remote control:
 - ☞ by pressing the “closed padlock” button briefly 3 times to fold them,
 - ☞ by pressing the “open padlock” button briefly 3 times to unfold them.

The folding and unfolding of the exterior mirrors can be configured via the colour display “Equipment” menu or deactivated by a CITROËN dealer.

The mirrors can also be folded manually.

 If you have folded the mirrors using the control **C**, you must use this control to unfold them, otherwise the mirrors will not be locked correctly.

If you switch the engine off then restart it with the mirrors folded, they will unfold automatically when the vehicle reaches 20 mph (30 km/h).

If the mirrors have been folded manually or electrically after starting the engine, they are not unfolded automatically.

In this case:

- ☞ Press the control **C** to unfold them.

INTERIOR MIRROR



Adjust the mirror by moving it up or down and/or to the left or right.

The interior mirror has two positions:

- day (normal),
- night (anti-dazzle).

To change from one to the other, push or pull the lever on the lower edge of the mirror.

MANUAL STEERING WHEEL HEIGHT ADJUSTMENT

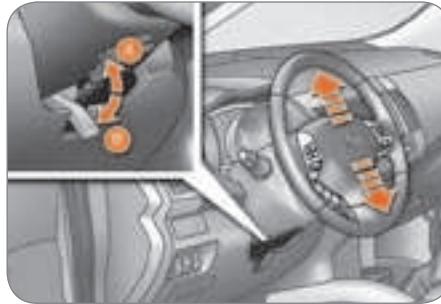

- ☞ Pull the locking lever downwards (position **B**) while supporting the steering wheel.
- ☞ Adjust the steering wheel to the required height.
- ☞ Lock the steering wheel by pushing the lever upwards (position **A**).

SUN VISOR

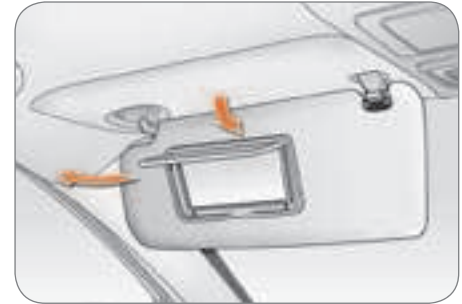

The sun visors fold forwards, and to the side when they are unhooked.

They are fitted with a courtesy mirror and a ticket holder.



As a safety precaution, it is imperative that these operations are carried out while the vehicle is stationary.



FRONT INTERIOR LAYOUT

1. Spectacles storage.
2. Storage compartment.
3. Upper glove box with air conditioning.
4. Lower glove box with lock.
5. Lighter
12 volt socket (120 W max).
6. Armrest with storage compartments
12 volt socket (120 W max).
7. Cup holder.
8. Removable ashtray.
9. Bottle holder.
10. Enclosed storage compartment.
11. Cup holder.

Spectacles storage



Press the cover to open it.
To close it, push the cover until it locks.

Storage box

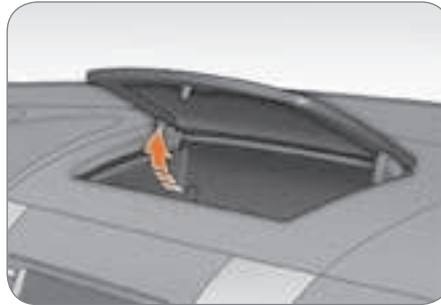

Press the front part of the lid to open.
To close, fold down the lid until it locks.

Upper glove box with air conditioning

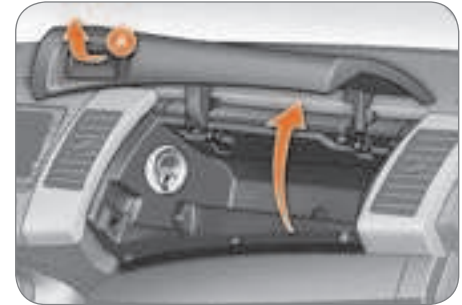

Press button **A** on the lid to open it.
To close it, push the lid up.
It is fitted with a ventilation nozzle which can be closed by means of a dial, distributing conditioned air at the same temperature as the vents in the passenger compartment.
In cold weather, it is advisable to close this vent to conserve the ambient air inside the passenger compartment.

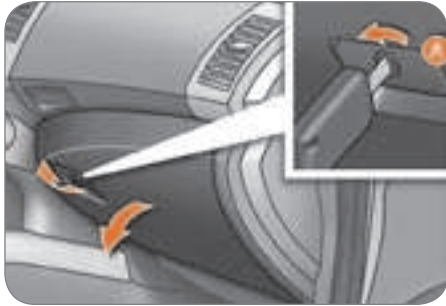
Lower glove box

This is fitted with a lock.
 To unlock it, turn the key to the left.
 To open it, pull the handle **A**.
 To close it, push the lid up.
 To lock it, turn the key to the right.
 It is fitted with a pen holder and a card holder.
 It is lit on opening when the lights stalk is activated.

**Lighter
12 volt socket (120 W max)**

When the ignition switch is in the "ON" or "ACC" position, press the lighter.
 After a moment you hear a click when the lighter pops out.
 When the lighter socket is used to connect electrical equipment, ensure that this equipment operates correctly with a voltage of 12 volts and has an electrical power of 120 W maximum.

**Armrest with storage compartments
12 volt socket (120 W max)****Upper storage compartment**

Pull the right-hand lever to open the storage compartment lid, which serves as an armrest.
 To close, fold down the lid until it locks.



The prolonged use of electrical equipment without running the engine may discharge the battery.

Lower storage compartment



Pull the left-hand lever to open the lid.
To close, fold down the lid until it locks.

12 volt socket (120 W max)



This operates when the ignition switch is in the "LOCK", "ACC" or "ON" position.
Open the cover to gain access to the socket.

Removable ashtray



Pull the cover to open the ashtray.
To empty, remove the ashtray by pulling it upwards.



Check that the electrical equipment operates with 12 volts and that its maximum electrical power is 120 W.

When you use the two sockets at the same time, ensure that the two items of equipment together operate with 12V and that their combined electrical power is 120W maximum.

The prolonged use of electrical equipment without running the engine may discharge the battery.

Enclosed storage compartment



Pull the storage compartment lid to open it.

Cup holder



There is a cup holder incorporated in the fascia on the driver's side.
Press on the centre of the cover to extract the plate.
Pull it fully to use it.
Push it fully to store it.



Two further cup holders are available in front of the front armrest.

REAR INTERIOR LAYOUT

Rear armrest



Pull the armrest forwards to lower it.

Bottle holder



There is a bottle holder in each rear door.

Coat hook



The rear left grab handle is fitted with a coat hook.

Cup holder



Open the cover **A** located at the end of the armrest holding the side with your hand.

Grab handle



Pull the handle downwards to lower it.



DVD player

This video assembly will allow the rear passengers to pass the time agreeably while watching their favourite film or playing their favourite game, in particular by means of the connection of a DVD player or games console.

This video assembly consists of:

- a 9 inch colour screen,
- two wireless HF stereo headphones,
- a remote control.



The screen is incorporated in a central console on the roof.



The three video sockets are located under the cover at the rear of the central armrest.





BOOT LAYOUT

1. 12 volt socket (120 W max).
2. Open storage compartment.
3. Right-hand side enclosed storage compartment.
4. Storage compartment in the floor*.
5. Stowing rings.
6. Left-hand side storage compartment or audio equipment.
7. Load space cover.

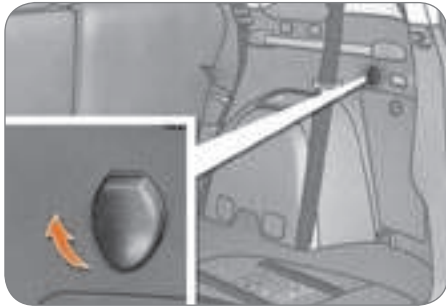

* 5-seat version only.

12 volt socket (120 W max)

This operates when the ignition switch is in the "ON" or "ACC" position.
Lift the cover to gain access to the socket.



Check that the electrical equipment operates with 12 volts and that its maximum electrical power is 120 W.

The prolonged use of electrical equipment without running the engine may discharge the battery.

Stowing rings

There are four stowing rings in the boot for securing luggage:

- two rings are located on the boot floor,
- two rings are located on the rear side pillars.

Storage compartment in the floor*

Raise the boot floor to gain access to this compartment.

Right-hand side enclosed storage compartment

This storage compartment contains the tools for changing a wheel.

*On 5-seat version only.

Load space cover

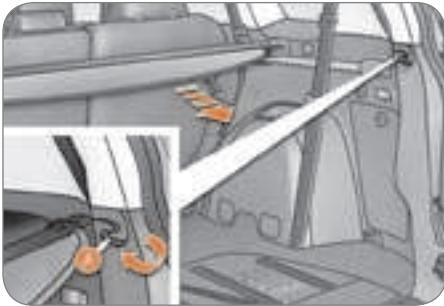

Unroll the load space cover and install it in the securing groove **A**.

To store the load space cover, release it from the securing groove, it rolls up to its initial position.

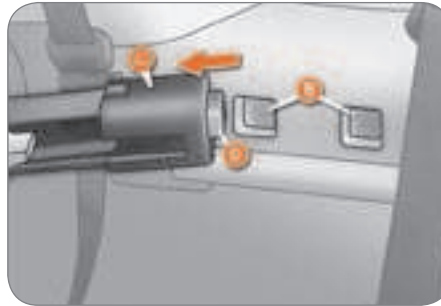
**Second installation position.**

The load space cover can be secured in two different positions **B**, so that the row 2 seat backs can be tilted.

1. Roll up the load space cover.
2. Move one of the slides **C** towards the inside of the vehicle and insert the tab **D** in the installation hole to be used.
Move the opposite slide in the same way.
3. After changing the position, check that the load space cover is secured correctly.

**Removing the load space cover.**

1. Roll up the load space cover.
2. Move one of the slides **C** towards the inside of the vehicle and raise it.
Release the opposite slide in the same way.

To put the load space cover in place, carry out the operations in reverse order.



Take care not to place heavy objects on the load space cover when it is unfolded.

The load space cover can be stored along the lower tailgate, unless audio equipment is present.

REMOTE CONTROL KEY

System which permits central unlocking or locking of the vehicle using the lock or from a distance. It also folds and unfolds the mirrors, closes the electric windows and starts the vehicle, as well as providing protection against theft.

III



Unlocking the vehicle

Unfolding the key

☞ First press button **A** to unfold the key.

Unlocking using the remote control



☞ Press the open padlock to unlock the vehicle.

Unlocking is confirmed by the interior lighting which comes on for approximately 15 seconds and the direction indicators which flash **twice**.

If you press the open padlock **twice in succession** within 30 seconds after unlocking the vehicle, the exterior mirrors unfold.

Unlocking using the key

☞ Turn the key to the right in the **driver's door** lock to unlock the vehicle.

Locking the vehicle

Normal locking using the remote control



☞ Press the closed padlock to lock the vehicle.

Locking is confirmed by the direction indicators which come on **once**.

If you press the closed padlock **twice in succession** within 30 seconds after locking the vehicle, the exterior mirrors fold.

An extended press on the closed padlock within 30 seconds after locking the vehicle permits automatic closing of the windows.

Normal locking using the key

☞ Turn the key to the left in the **driver's door** lock to lock the vehicle.

If one of the doors or the tailgate is still open, the central locking will not take place.



Folding the key

☞ First press button **A** to fold the key.

The vehicle will relock automatically after thirty seconds unless a door or the tailgate is opened. This function prevents inadvertent unlocking.

The duration which precedes the automatic relocking of the vehicle can be configured via the colour display "Equipment" menu.

Anti-theft protection

Electronic engine immobiliser

The key contains an electronic chip which has a special code. When the ignition is switched on, this code must be recognised to permit starting.

This electronic engine immobiliser locks the engine management system a few moments after the ignition is switched off and prevents starting of the engine by anyone who does not have the key.

In the event of a malfunction and if your vehicle does not start; contact a CITROËN dealer as soon as possible.

Starting the vehicle



III

- ☞ Insert the key in the ignition switch.
- ☞ Operate the starter by turning the key to position **4 (START)**.
- ☞ When the engine turns over, release the key. The ignition switch is placed in position **3 (ON)** automatically.

Switching the vehicle off

- ☞ Park the vehicle.
- ☞ While pressing the key, turn it towards you to position **1 (LOCK)**.
- ☞ Remove the key from the ignition switch.

Key in ignition

A buzzer sounds on opening the driver's door, if the key has been left in the ignition.

Changing the battery



Battery reference: CR1616 / 3 volts.

- ☞ Unclip the casing using a coin at the notch.
- ☞ Slide the flat battery out of its housing.
- ☞ Slide the new battery into its housing observing the original direction.
- ☞ Clip the casing.



Keys

Make a careful note of the number of each key. This number is coded on the label attached to the key. If the keys are lost, a CITROËN dealer can supply you with new keys.

Remote control

The high frequency remote control is a sensitive system; do not operate it while it is in your pocket as there is a possibility that it may unlock the vehicle, without you being aware of it.

Do not repeatedly press the buttons of your remote control out of range and out of sight of your vehicle.

You run the risk of stopping it from working. The remote control does not operate when the key is in the ignition, even when the ignition is switched off.

Locking the vehicle

Driving with the doors locked may make access to the passenger compartment by the emergency services more difficult in an emergency.

As a safety precaution (with children on board), remove the key from the ignition when you leave the vehicle, even for a short time.

Anti-theft protection

Do not make any modifications to the electronic engine immobiliser system, this could cause malfunctions.

When purchasing a second-hand vehicle

Have the key codes memorised by a CITROËN dealer, to ensure that the keys in your possession are the only ones which can start the vehicle.

Do not throw the remote control batteries away, they contain metals which are harmful to the environment. Take them to an approved collection point.





Folding the key

☞ First press button **A** to fold the key.

The vehicle will relock automatically after thirty seconds unless a door or the tailgate is opened. This function prevents inadvertent unlocking.

The duration which precedes the automatic relocking of the vehicle can be configured via the colour display "Equipment" menu.

Anti-theft protection

Electronic engine immobiliser

The key contains an electronic chip which has a special code. When the ignition is switched on, this code must be recognised to permit starting.

This electronic engine immobiliser locks the engine management system a few moments after the ignition is switched off and prevents starting of the engine by anyone who does not have the key.

In the event of a malfunction and if your vehicle does not start; contact a CITROËN dealer as soon as possible.

ELECTRIC WINDOWS

System which opens or closes a window manually or automatically. It is fitted with a system which provides protection if an obstacle is detected on one-touch models and a deactivation system to prevent misuse of the rear controls.

III

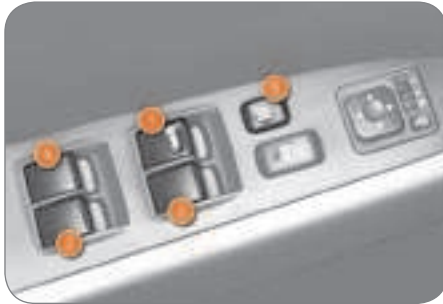

1. Driver's electric window switch.
2. Passenger's electric window switch.
3. Rear right electric window switch.
4. Rear left electric window switch.
5. Disarming of the passenger and rear electric window switches.

Operation

With the ignition on, you have two options:

- **manual mode**
 - ☞ Press the switch gently to open or pull it gently to close. The window stops as soon as the switch is released.
- **automatic mode**
 - ☞ Press the switch fully to open or pull it fully to close. The window opens or closes completely when the switch is released.
 - ☞ Pressing the switch again stops the movement of the window.

Safety auto-reverse

In automatic mode, when the window rises and meets an obstacle, it stops and lowers again.

In the event of unwanted opening of the window on closing (for example in the presence of frost), reinitialise the electric windows (refer to the corresponding paragraph).

The electric window switches can be configured via the colour display "Equipment" menu.

The electric window switches remain operational for approximately 30 seconds after the ignition is switched off and the switch on the driver's door remains operational for a further 30 seconds when the door is opened.

The windows can no longer be opened or closed after the driver's door is closed.

The rear windows do not lower fully.

Disarming the passenger and rear electric window switches



- ☞ For the safety of your children, press switch **5** to prevent operation of the passenger and rear electric windows irrespective of their position.

When the button is pressed down, disarming is active.

When the button is raised, disarming is deactivated.

When the button is pressed down, you can open or close all of the windows using the switches on the driver's door.

Reinitialising the electric windows

Following reconnection of the battery or after the safety auto-reverse has been triggered three times in succession, you must reinitialise the safety auto-reverse function:

- ☞ with the door closed, lower the window completely then raise it again, it will rise in steps of a few centimetres each time the switch is pressed, repeat the operation until the window is fully closed,
- ☞ continue to press the switch for at least one second after reaching the window closed position.

The safety auto-reverse function is not active during these operations.



Always remove the key from the ignition when leaving the vehicle, even for a short time.

In the event of contact during operation of the windows, you must reverse the movement of the window. To do this, press the switch concerned.

When the driver operates the passenger electric window switches, he must ensure that no one is preventing correct closing of the windows.

The driver must ensure that the passengers use the electric windows correctly.

Be aware of children when operating the windows.

DOORS

Opening

III



From outside

- ☞ After unlocking the vehicle using the remote control or the key, pull the door handle.

From inside



- ☞ Pull the front or rear door control to open the door.

If the doors are locked, opening the driver's door unlocks all of the doors. The front passenger door or the rear doors must first be unlocked manually using the locking control before being opened.

Closing



If a door is not closed correctly, this warning light comes on on the instrument panel display until the door concerned is closed.

Manual centralised control

System which provides full manual locking or unlocking of the doors and tailgate from the inside.



Locking

- ☞ Press the front of button **A** to lock the vehicle.

If the driver's door is open when you operate the central locking from inside, all of the doors lock with the exception of the driver's door.

Unlocking

- ☞ Press the rear of button **A** to unlock the vehicle.

Emergency control

System which locks or unlocks the doors mechanically in the event of a malfunction of the central locking.

Using the key



Locking the driver's door

☞ Insert the key in the lock, then turn it to the left.

Unlocking the driver's door

☞ Insert the key in the lock, then turn it to the right.

Locking the front passenger door and the rear doors (from inside)

☞ Tilt the interior control **B** forwards.



Unlocking the front and rear doors (from inside)

☞ Tilt the interior control **B** rearwards.

TAILGATE

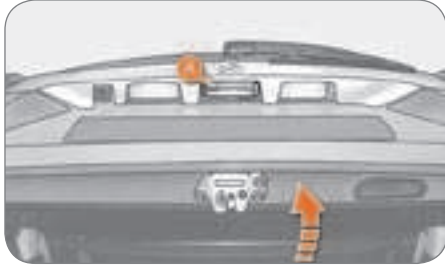

Opening

- ☞ After unlocking the vehicle using the remote control or the key, press the handle **A** and raise the tailgate.



Closing

- ☞ Pull the handle **B** downwards to guide the tailgate,
- ☞ release the handle and press the exterior surface of the tailgate gently to close it.

LOWER TAILGATE

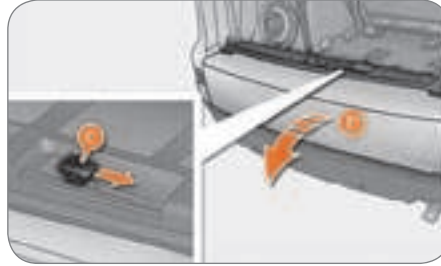

Opening

- ☞ Push the handle **C** to the right and tilt the tailgate **D** gently.



Closing

- ☞ Raise the tailgate **D**, push it to close it, then check that it is secured correctly.

“Tailgate open” warning



This warning light comes on the instrument panel display when the tailgate is not closed correctly.

Before opening the tailgate, ensure that no one is within the radius of opening.

For reasons of safety and correct operation, do not drive with the tailgate open.

If the battery is disconnected, the tailgate cannot be opened.

Do not climb onto the lower tailgate and do not subject it to heavy knocks, it may be damaged.

Always close the lower tailgate and check that it is secured correctly before closing the main tailgate.

When closing the lower tailgate, ensure that no person or object is in the proximity of the moving parts to avoid any risk of injury or damage.

Do not open the lower tailgate when a towbar is fitted.

Maximum authorised weight on the lower tailgate when open: **200 kg**.

Tailgate release

This enables the tailgate to be unlocked in the event of a central locking fault.



- Fold back the rear seats to gain access to the tailgate release from inside the boot.
- Remove the plastic cap from the opening **A** in the tailgate interior pillar.



- Move the control **B** to the right to unlock and open the tailgate.

SUNROOF

System which improves the ventilation and light in the passenger compartment. It is fitted with a protection system to prevent pinching and a shutter to help maintain a comfortable temperature.

Operation



Complete opening

☞ With the ignition on, push the control rearwards (in the direction 1).

A deflector is deployed gradually on opening to prevent unwanted gusts of air.

The sunroof stops automatically just before complete opening. Push the control again for complete opening.

Complete closing

☞ With the ignition on, push the control forwards (in the direction 2).

The deflector folds down gradually on closing.

Temporary stop

☞ To stop opening or closing, press part **3** of the control or push the control in the opposite direction.



Partial opening

☞ **To open**, with the ignition on, press part **3** of the control.

The rear part of the sunroof opens.

☞ **To close**, with the ignition on, press part **3** of the control.

The rear part of the sunroof closes.

Tailgate release

This enables the tailgate to be unlocked in the event of a central locking fault.



- Fold back the rear seats to gain access to the tailgate release from inside the boot.
- Remove the plastic cap from the opening **A** in the tailgate interior pillar.



- Move the control **B** to the right to unlock and open the tailgate.

SUNROOF

System which improves the ventilation and light in the passenger compartment. It is fitted with a protection system to prevent pinching and a shutter to help maintain a comfortable temperature.

Operation



Complete opening

☞ With the ignition on, push the control rearwards (in the direction 1).

A deflector is deployed gradually on opening to prevent unwanted gusts of air.

The sunroof stops automatically just before complete opening. Push the control again for complete opening.

Complete closing

☞ With the ignition on, push the control forwards (in the direction 2).

The deflector folds down gradually on closing.

Temporary stop

☞ To stop opening or closing, press part **3** of the control or push the control in the opposite direction.



Partial opening

☞ **To open**, with the ignition on, press part **3** of the control.

The rear part of the sunroof opens.

☞ **To close**, with the ignition on, press part **3** of the control.

The rear part of the sunroof closes.

Safety auto-reverse and reinitialisation

If the roof meets an obstacle while it is closing, it stops and opens again.

III

In the event of unwanted opening of the roof on closing (for example, in the presence of ice) and immediately after the roof has stopped, or after the safety auto-reverse has been triggered five times in succession:

- ☞ press part **3** of the control several times to partially open the roof,
- ☞ when the roof partially opens, continue to press for **more than 3 seconds**.
- ☞ open and close the sunroof completely.

The safety auto-reverse function is not operational during these operations.



Always remove the key from the ignition when leaving the vehicle, even for a short time.

If the roof meets an obstacle during operation, you must reverse the movement of the roof. To do this, press the control concerned.

When the driver operates the roof control, he must ensure that no one is preventing the roof from closing correctly.

The driver must ensure that passengers use the sunroof correctly.

Be aware of children when operating the roof.

SHUTTER



The shutter is manual, slide it.

It is stored automatically when the roof is opened.



Check that the sunroof is not open **in tilt mode** before closing the shutter.

The shutter cannot be closed when the sunroof is open in **sliding mode**.

FUEL TANK

System for filling with fuel, after taking into account the detection of the associated low level.

Capacity of the tank: approximately 60 litres.

Low fuel level



When the tank's minimum level is reached (approximately 10 litres), this indication appears on the instrument panel display.

The symbol **flashes slowly** (approximately once per second).

You have enough fuel remaining to drive approximately 30 miles (50 km).



When the symbol begins to **flash rapidly** (approximately twice per second), there is not much fuel remaining in your tank (approximately 5 litres).

Filling

A label, affixed on the inside of the flap, reminds you of the type of fuel to be used in relation to your engine.

Location of the cap



This symbol indicates that the fuel tank cap is located on the left-hand side of the vehicle.

To fill the tank safely:

- ☞ **it is imperative that the engine is switched off,**
- ☞ pull the control **A** located at the bottom left of the driver's seat to release the fuel filler flap,
- ☞ open the fuel filler flap **B**,
- ☞ turn the cap **C** to the left,
- ☞ remove the cap **C**,
- ☞ fill the tank, but **do not continue after the 3rd cut-off of the nozzle**; this could cause malfunctions.

When you have filled the tank:

- ☞ refit the cap, inserting the upper part first,
- ☞ screw in the cap to the right,
- ☞ close the flap.

Ensure that the fuel filler flap is closed correctly.

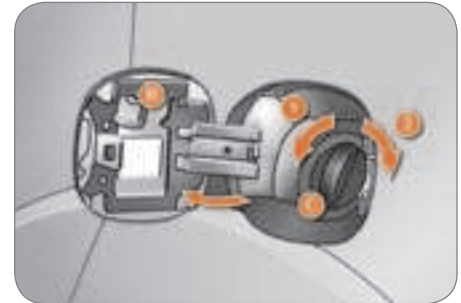

1. Opening.
2. Closing.

LIGHTS STALK

System for selection and control of the various front and rear lights providing the vehicle's lighting.

Main lighting

The various front and rear lights of the vehicle are designed to adapt the driver's visibility progressively in relation to the climatic conditions:

- side lights, to be seen,
- dipped headlamps to see without dazzling other drivers,
- main beam headlamps to see clearly when the road is clear.

Additional lighting

Other lights are installed to fulfil the requirements of particular driving conditions:

- rear fog lamps to be seen from a distance,
- front fog lamps for even better visibility,
- daytime lights to be seen during the day.

Certain functions of the lights stalk (automatic lighting, sensitivity) can be configured via the colour display "Equipment" menu.



Manual controls

The lighting commands are issued directly by the driver by means of the ring **A** and the lever **B**.

A. main lighting mode selection ring, with:

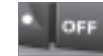

lights off,



automatic switching on of the lights,



side lights only,



dipped headlamps or main beam headlamps.

B. lever for inversion of the lights by pulling: dipped headlamps / main beam headlamps.

In the lights off and side lights modes, the driver can switch on the main beam headlamps directly ("headlamp flash") for as long as he pulls the lever.

Displays

Lighting of the corresponding indicator light on the instrument panel confirms the selective switching on of the lighting selected.

Front and rear fog lamps



C. fog lamps selection ring.

The fog lamps operate with the dipped and main beam headlamps.

If condensation is present, it is advisable to switch the headlamps on for a few minutes in order to clear it.



front and rear fog lamps

- ☞ To switch on the front fog lamps, turn the push ring **C** forwards one notch.
- ☞ To switch on the rear fog lamps, turn the push ring **C** forwards two notches.
- ☞ To switch off the front fog lamps, turn the push ring **C** rearwards one notch.
- ☞ To switch off the rear fog lamps, turn the push ring **C** rearwards two notches.

The ring **C** returns to its initial position automatically.

The front fog lamps are switched on automatically when you switch on the rear fog lamps.

The rear fog lamps are switched off automatically when you switch off the dipped/main beam headlamps or the front fog lamps.

On vehicles fitted with daytime lights, the rear fog lamps can be switched on even if the lights stalk is in the "OFF" position.



In good or rainy weather, both day and night, the front fog lamps and the rear fog lamps are prohibited. In these situations, the power of their beams may dazzle other drivers.

Do not forget to switch off the front fog lamps and the rear fog lamps when they are no longer necessary.

Lights on buzzer

The triggering of an audible signal when the driver's door is opened warns the driver that he has forgotten to switch off his vehicle's lights, with the ignition off.

In this case, switching off the lights stops the audible signal.

Daytime lights*

On vehicles which are equipped with daytime lights, the dipped headlamps come on when the vehicle is started.



This warning light comes on on the instrument panel.

The instruments and controls (instrument panel, multifunction display, air conditioning control panel, ...) are lit.

IV

Automatic lighting

The side lights and the dipped headlamps come on automatically, without any action on the part of the driver, if a low level of exterior light is detected or if the wipers are switched on.

When the light returns to a sufficient level or the wipers are switched off, the lights are switched off automatically.

The sensor is located at the base of the windscreen.

Contact a CITROËN dealer to adjust the sensitivity of the sensor.

Automatic switching off

When the lights stalk is at “dipped headlamps or main beam headlamps”, if the ignition switch is at “LOCK” or “ACC” or if the key has been removed from the ignition switch, the lights switch off automatically **when the driver’s door is opened**.



In foggy weather or in snow, the brightness sensor can detect sufficient light. The lights will not come on automatically.

Do not cover the brightness sensor, the associated functions will no longer be controlled.

The sensitivity of the automatic lighting can be configured via the colour display “Equipment” menu.

*According to country.

MANUAL ADJUSTMENT OF THE HEADLAMPS



To avoid dazzling other road users, the height of the headlamps must be adjusted in relation to the load in the vehicle.

5-seat version

0. Driver only or Driver + 1 passenger in the front.
- 1 or 2. 5 occupants (including the driver).
3. 5 occupants (including the driver) + maximum authorised load.
4. Driver + maximum authorised load.

7-seat version

0. Driver only or Driver + 1 passenger in the front.
- 1 or 2. Driver + 1 passenger in the front + 2 passengers on the third bench seat.
3. 7 occupants (including the driver with or without maximum authorised load).
4. Driver + maximum authorised load.

AUTOMATIC HEADLAMP ADJUSTMENT



On vehicles with xenon bulbs: **when stationary**, the system automatically corrects the height of the beam, whatever the load of the vehicle. The driver is then assured of having optimum lighting and not causing a nuisance to other road users.



In cases of malfunction, this message appears on the multifunction display.

Do not touch the xenon bulbs. Consult a CITROËN dealer.

WIPER CONTROLS

System for selection and control of the various front and rear wiping modes for the elimination of rain and cleaning.

The vehicle's various front and rear wipers are designed to improve the driver's visibility progressively in relation to the climatic conditions.

IV



Manual controls

The wiper commands are issued directly by the driver by means of the lever **A** and the ring **B**.

Windscreen wipers

A. wiping speed selection lever:

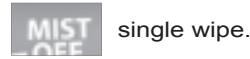

single wipe.



park.

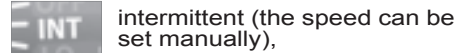

intermittent (the speed can be set manually),



slow.



fast.

B. intermittence adjustment ring.

You can increase or decrease the wiping frequency when the intermittent mode is active.

Certain windscreen wiper functions (intermittence, ...) can be configured via the colour display "Equipment" menu.

Windscreen wash

Pull the wipers stalk towards you. The windscreen wash then the wipers operate for a set time.

The headlamp wash is also activated if **the dipped headlamps are on.**

Headlamp wash



Press the end of the lights stalk to activate the headlamp wash, when the dipped headlamps are on.

Rear wiper



A. rear wiper selection ring:

OFF • park

INT • intermittent wiper

WASH • wipe with screen wash

The wiper wipes twice then switches to intermittent mode with an interval of a few seconds.

Keep the ring in this position to operate the screen wash with several wipes of the wiper.

The intermittence of the rear wiper can be configured via the colour display “Equipment” menu.

COURTESY LIGHTS

System for selection and control of the various passenger compartment lights.

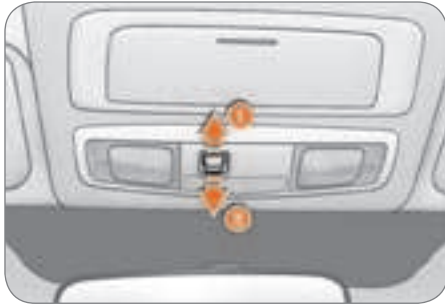

IV

Front courtesy light

Position 1

The courtesy light comes on when a door or the tailgate is opened.

When the door or the tailgate is closed again, the lighting gradually dims for a few seconds before switching off.

However, the courtesy light is switched off automatically in the following cases:

- When the doors and the tailgate are closed and the ignition switch is placed in the “ON” position.
- When the doors and the tailgate are closed and you lock the vehicle from inside or using the remote control.

Position 2

The courtesy light is off, regardless of whether the doors or tailgate are open or closed.

The durations of lighting of the front courtesy lights can be configured via the colour display “Equipment” menu.



Map reading lights

There are two map reading lights, one on each side of the courtesy light. Press the corresponding transparent block **A**.

Rear courtesy light

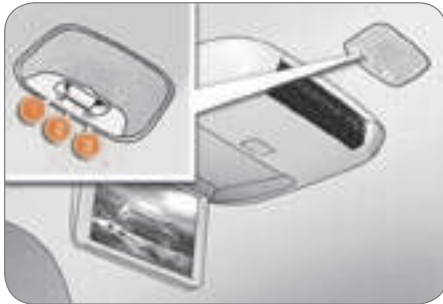

Position 1 "ON"

The courtesy light is permanently on.

Position 2 "●"

The courtesy light comes on when a door or the tailgate is opened. When the door or the tailgate is closed again, the lighting gradually dims for a few seconds before switching off.

However, the courtesy light is switched off immediately in the following cases:

- When the doors and the tailgate are closed and the ignition switch is placed in the "ON" position.

- When the doors and the tailgate are closed and you lock the vehicle from inside or using the remote control.

Position 3 "OFF"

The courtesy light is permanently off.

Boot courtesy light



Position 1 "ON"

The courtesy light is on, regardless of whether the tailgate is open or closed.

Position 2 "●"

The courtesy light comes on if the tailgate is opened and switches off when the tailgate is closed.

Position 3 "OFF"

The courtesy light is off, regardless of whether the tailgate is open or closed.

Automatic switching off of the courtesy lights

To prevent discharging of the battery, the courtesy lights and map reading lights switch off automatically after 30 minutes.

The courtesy lights are switched on again if the ignition switch is placed in the "ON" or "ACC" position, if you open then close a door or the tailgate or if you use the remote control.

The durations of lighting of the rear courtesy lights can be configured via the colour display "Equipment" menu.

GENERAL POINTS RELATING TO CHILD SEATS

Although one of CITROËN's main criteria when designing your vehicle, the safety of your children also depends on you.

For maximum safety, please follow these precautions:

- in accordance with Directive 2003/20, all children under the age of 12 or less than one metre fifty* tall must travel in approved child seats suited to their weight, on seats fitted with a seat belt or ISOFIX mountings *
- statistically, the safest seats in your vehicle for the transportation of children are the rear seats,
- a child weighing less than 9 kg must travel in the "rearwards-facing" position both in the front and in the rear.

INSTALLING A CHILD SEAT USING A THREE POINT SEAT BELT

"Rearwards-facing"



"Forwards-facing"



When a "rearwards-facing" child seat is installed on the **front passenger seat**, it is essential that the passenger air bag is disarmed. **Otherwise, the child would risk being seriously injured or killed if the air bag were to inflate.**

When a "forwards-facing" child seat is installed on the **front passenger seat**, adjust the vehicle's seat to the intermediate longitudinal position with the seat back upright and leave the passenger air bag armed.



Intermediate longitudinal position

CITROËN recommends that children should travel in **the rear seats** of your vehicle:

- "rearwards-facing" up to the age of 2,
- "forwards-facing" over the age of 2.

*The rules for transporting children are specific to each country. Consult the current legislation in your country.



ADVICE ON CHILD SEATS

The incorrect installation of a child seat in a vehicle compromises the child's protection in the event of an accident.

Remember to fasten the seat belts or the child seat harnesses keeping the slack in relation to the child's body **to a minimum**, even for short journeys.

For optimum installation of the "forward facing" child seat, ensure that the back of the child seat is in contact with the back of the vehicle's seat and that the head restraint does not cause any discomfort.

If the head restraint has to be removed, ensure that it is stored or attached securely to prevent it from being thrown around the vehicle in the event of sharp braking.

Children under the age of 10 must not travel in the "forward facing" position on the front passenger seat, unless the rear seats are already occupied by other children, cannot be used or are absent.

Disarm the passenger air bag when a "rear facing" child seat is installed on the front seat. Otherwise, the child would risk being seriously injured or killed if the air bag were to inflate.

Installing a booster seat

The chest part of the seat belt must be positioned on the child's shoulder without touching the neck.

Ensure that the lap part of the seat belt passes correctly over the child's thighs.

CITROËN recommends the use of a booster seat which has a back, fitted with a seat belt guide at shoulder level.

As a safety precaution, do not leave:

- one or more children alone and unsupervised in a vehicle,
- a child or an animal in a vehicle which is exposed to the sun, with the windows closed,
- the keys within reach of children inside the vehicle.

To prevent accidental opening of the doors, use the "Child lock".

Take care not to open the rear windows by more than one third.

To protect young children from the rays of the sun, fit side blinds on the rear windows.

CHILD LOCK

Mechanical system to prevent opening of the rear door using its interior control.

The control is located on the edge of each rear door.

Locking



☞ Lower the control **A** to position **1**.

Unlocking

☞ Raise the control **A** to position **2**.

GENERAL POINTS RELATING TO CHILD SEATS

Although one of CITROËN's main criteria when designing your vehicle, the safety of your children also depends on you.

For maximum safety, please follow these precautions:

- in accordance with Directive 2003/20, **all children under the age of 12 or less than one metre fifty* tall must travel in approved child seats suited to their weight**, on seats fitted with a seat belt or ISOFIX mountings *;
- **statistically, the safest seats in your vehicle for the transportation of children are the rear seats**;
- **a child weighing less than 9 kg must travel in the "rearwards-facing" position both in the front and in the rear.**

CITROËN **recommends** that children should travel in **the rear seats** of your vehicle:

- **"rearwards-facing"** up to the age of 2,
- **"forwards-facing"** over the age of 2.

INSTALLING A CHILD SEAT USING A THREE POINT SEAT BELT

"Rearwards-facing"



When a "rearwards-facing" child seat is installed on the **front passenger seat**, it is essential that the passenger air bag is disarmed. **Otherwise, the child would risk being seriously injured or killed if the air bag were to inflate.**

"Forwards-facing"



When a "forwards-facing" child seat is installed on the **front passenger seat**, adjust the vehicle's seat to the intermediate longitudinal position with the seat back upright and leave the passenger air bag armed.



Intermediate longitudinal position

*The rules for transporting children are specific to each country. Consult the current legislation in your country.

CHILD SAFETY

CHILD SEATS RECOMMENDED BY CITROËN

CITROËN offers a complete range of recommended child seats which are secured using a three point seat belt:

Group 0: from birth to 10 kg
Group 0+: from birth to 13 kg



L1
"ROMER Baby-Safe Plus"
Installed in the rear-facing position

Groups 1, 2 and 3: from 9 to 36 kg



L2
"KIDDY Life"
For the safety of young children (from 9 to 18 kg), CITROËN recommends use of the restraining cushion.

Groups 2 and 3: from 15 to 36 kg



L3
"RECARO Start"



L4
"KLIPPAN Optima"
From the age of 6 years (approximately 22 kg), the booster is used on its own.







Passenger air bag OFF

V

CHILD SAFETY

LOCATION OF CHILD SEATS SECURED USING THE SEAT BELT

In accordance with European regulations (Directive 2005/40), this table indicates the options for installing child seats secured using a seat belt and universally approved (a) in relation to the weight of the child and the seat in the vehicle.

Seat	Weight of the child and indicative age			
	Less than 13 kg (groups 0 (b) and 0+) Up to ≈ 1 year	From 9 to 18 kg (group 1) From 1 to ≈ 3 years	From 15 to 25 kg (group 2) From 3 to ≈ 6 years	From 22 to 36 kg (group 3) From 6 to ≈ 10 years
Front passenger seat (c) with passenger air bag activated 	X	L2	L3, L4	L3, L4
Front passenger seat (c) with passenger air bag disarmed 	L1	L2	L3, L4	L3, L4
Rear side seats (row 2) 	U	U	U	U
Rear centre seat (row 2) 	L1	L2	L3, L4	L3, L4
Rear side seats (row 3) 	L1	L2	L3, L4	L3, L4

(a) Universal child seat: child seat which can be installed in all vehicles using the seat belt.

(b) Group 0: from birth to 10 kg.

(c) Consult the legislation in force in your country before installing your child on this seat.

U: seat suitable for the installation of a child seat secured using the seat belt and universally approved, “rear facing” and/or “forward facing”.

X: seat not suitable for the installation of a child seat of the weight group indicated.

L-: only the child seats indicated can be installed on the seat concerned (according to country).

“ISOFIX” MOUNTINGS

Your vehicle has been approved in accordance with the **new ISOFIX regulation**.

The seats, represented below, are fitted with regulation ISOFIX mountings:



These are three rings for each seat:



- two rings **A**, located between the vehicle seat back and cushion, indicated by a label,



- a ring **B**, used to fix the upper strap, referred to as the **TOP TETHER**, indicated by a label.

This ISOFIX mounting system guarantees you fast, reliable and safe fitting of the child seat in your vehicle.

The **ISOFIX child seats** are fitted with two locks which are secured easily on the two rings **A**.

Some also have an **upper strap** which is attached to the ring **B**.

To attach this strap, remove the vehicle seat's head restraint. Then fix the hook on the ring **B** and tighten the upper strap.



The incorrect installation of a child seat in a vehicle compromises the child's protection in the event of an accident.

For information regarding the ISOFIX child seats which can be installed in your vehicle, consult the summary table for the location of the ISOFIX child seats.

ISOFIX CHILD SEAT RECOMMENDED BY CITROËN AND APPROVED FOR YOUR VEHICLE

ISOFIX RÖMER Duo Plus (size category B1)

Group 1: from 9 to 18 kg



Installed in the forward facing position.
Fitted with an upper strap to be secured on the ISOFIX upper ring,
referred to as the TOP TETHER.
Three seat body angles: sitting, reclining, lying.

V

This child seat can also be used on seats which are not fitted with ISOFIX mountings.
In this case, it must be attached to the vehicle seat using the three point seat belt.

Follow the instructions for fitting the child seat given in the seat manufacturer's installation guide.

SUMMARY TABLE FOR THE LOCATION OF ISOFIX CHILD SEATS

In accordance with European Regulations (ECE 16), this table indicates the options for installing ISOFIX child seats on seats in the vehicle fitted with ISOFIX mountings.

In the case of universal and semi-universal ISOFIX child seats, the ISOFIX size category, determined by a letter from **A** to **G**, is indicated on the child seat next to the ISOFIX logo.

	Weight of the child / indicative age									
	Less than 10 kg (group 0) Up to approx. 6 months		Less than 10 kg (group 0) Less than 13 kg (group 0+) Up to approx. 1 year			From 9 to 18 kg (group 1) From approx. 1 to 3 years				
Type of ISOFIX child seat	infant car seat		“rear facing”			“rear facing”		“forward facing”		
ISOFIX size category	F	G	C	D	E	C	D	A	B	B1
Universal and semi-universal ISOFIX child seats which can be installed on the rear seats	X		IL-SU			IL-SU		IUF IL-SU		

V

IUF: seat suitable for the installation of an Isofix Universal seat, “Forward facing” secured using the “Top Tether” upper strap.

IL-SU: seat suitable for the installation of an Isofix Semi-Universal seat either:

- “rear facing” fitted with a “Top Tether” upper strap or a support,
- “forward facing” fitted with a support.

For advice on securing of the “Top Tether” upper strap, refer to the “Isofix mountings section”.

X: seat not suitable for the installation of an ISOFIX seat of the size category indicated.

The head restraint of the vehicle’s ISOFIX seat must be removed and stored.

DIRECTION INDICATORS

Selection of the left or right direction indicators to signal a change of direction of the vehicle.



- ☞ Lower the lights stalk when moving to the left (position 1).
- ☞ Raise the lights stalk when moving to the right (position 1).

The indicator light on the instrument panel flashes.

Certain direction indicator functions can be configured via the colour display "Equipment" menu.

The "motorway" function

System for indicating a change of lane on a motorway.

Press up or down once (positions 2), without passing the point of resistance; the corresponding direction indicators will flash three times.

HAZARD WARNING LIGHTS

A visual warning by means of the direction indicators to alert other road users to a vehicle breakdown, towing or accident.



- ☞ Press button **A**, the direction indicators flash.

They can operate with the ignition off.



As a safety precaution in a traffic jam, switch on the hazard warning lights when you are the last in the queue.

HORN

Audible warning to alert other road users to an imminent danger.



- ☞ Press one of the spokes of the steering wheel.

BRAKING ASSISTANCE SYSTEMS

Group of supplementary systems which help you to obtain optimum braking in complete safety in emergency situations:

- the anti-lock braking system (ABS),
- the electronic brake force distribution (EBFD).

Anti-lock braking system and electronic brake force distribution

Linked systems which improve the stability and manoeuvrability of your vehicle when braking, in particular on poor or slippery surfaces.

Activation

The anti-lock braking system is active if the vehicle speed is higher than 6 mph (10 km/h). It is deactivated when the vehicle speed falls below 3 mph (5 km/h). The anti-lock braking system comes into operation automatically when there is a risk of wheel lock.

Normal operation of the ABS may make itself felt by slight vibration of the brake pedal.



When braking in an emergency, press very firmly without releasing the pressure.

Operating fault

When the vehicle is stationary



If this warning light comes on, accompanied by the indication on the instrument panel display, it indicates a malfunction of the anti-lock braking system which could result in a loss of control of the vehicle when braking.

Consult a CITROËN dealer.

The warning light comes on for a few seconds when the ignition is switched on (ON position). If it does not switch off or does not come on, contact a CITROËN dealer.

When the vehicle is moving



If this warning light comes on continuously it indicates a malfunction of the anti-lock braking system which could result in a loss of control of the vehicle on braking.

You MUST stop as soon as it is safe to do so.

Consult a CITROËN dealer.



If these two warning lights come on, linked with the warnings on the instrument panel display, they indicate a malfunction of the electronic brake force distribution which could result in a loss of control of the vehicle on braking.

You MUST stop as soon as it is safe to do so.

Consult a CITROËN dealer.

The two warning lights comes on at the same time and the two warnings are displayed alternately on the instrument panel display.

When replacing wheels (tyres and rims), ensure that they conform to the manufacturer's recommendations.

TRAJECTORY CONTROL SYSTEMS

Associated systems which guarantee the directional stability of the vehicle within the limits of the laws of physics:

- the anti-skid regulation (TCL),
- the electronic stability programme (ASC).

Anti-skid regulation and electronic stability programme

The anti-skid regulation optimises traction to prevent skidding of the wheels, by acting on the brakes of the driving wheels and on the engine.

The electronic stability programme acts on the brake of one or more wheels and on the engine to keep the vehicle on the trajectory required by the driver.

Activation

These systems are activated automatically each time the vehicle is started. They operate when the vehicle speed is higher than 10 mph (15 km/h).



They come into operation in the event of a grip or trajectory problem.

This is indicated by flashing of this symbol on the instrument panel display.

Disarming

In exceptional conditions (starting a vehicle which is bogged down, stuck in snow, on soft ground, ...), it may be advisable to disarm the ASC system, so that the wheels can move freely and regain grip.



- ➔ Press the “ASC OFF” button, located to the left of the steering wheel, until the ASC OFF symbol appears on the instrument panel display.



The displaying of this symbol in the top right corner of the instrument panel display indicates that the ASC and TCL systems are disarmed.

Reactivation

These systems are not reactivated automatically above 30 mph (50 km/h).

- ➔ Press the “ASC OFF” button again to reactivate them manually.

The switching off of the symbol in the top right corner of the instrument panel display indicates the reactivation of the ASC and TCL systems.

Operating fault



The displaying of this message on the instrument panel display indicates a malfunction of these systems.

Contact a CITROËN dealer to have the ASC/TCL systems checked.



The ASC/TCL systems offer exceptional safety in normal driving, but this should not encourage the driver to take extra risks or drive at high speed.

The correct functioning of these systems depends on observation of the manufacturer's recommendations regarding the wheels (tyres and rims), the braking components, the electronic components and the CITROËN assembly and operation procedures.

After an impact, have these systems checked by a CITROËN dealer.

SEAT BELTS

Front seat belts

The front seat belts are fitted with a pretensioning and force limiting system.

This system improves safety in the front seats in the event of a front impact. Depending on the severity of the impact, the pretensioning system instantly tightens the seat belts against the body of the occupants.

The pretensioning seat belts are active when the ignition is on.

The force limiter reduces the pressure of the seat belt on the chest of the occupant, so increasing his protection.

Fastening



- ☞ Pull the strap, then insert the tongue in the buckle **A**.
- ☞ Check that the seat belt is fastened correctly by pulling the strap.

Unfastening

- ☞ Press the red button on the buckle **A**.

Height adjustment



- ☞ to lower the attachment point, press the control **B** and slide the fixing **C** down,
- ☞ to raise the attachment point, press the control **B** and slide the fixing **C** up.

Front seat belt not fastened / unfastened warning light

Driver's seat belt



When the ignition is switched on, this warning light comes on accompanied by an audible signal for a few seconds if the driver has not fastened his seat belt.



If the driver does not fasten his seat belt within one minute after switching on the ignition, the warning light flashes accompanied by an intermittent audible signal and a display on the instrument panel display.

The warning light, the audible signal and the display stop after approximately 90 seconds and return until the driver fastens his seat belt.

If the seat belt is unfastened **while the vehicle is moving**, you are alerted by the same warnings.

Front passenger's seat belt



When the ignition is switched on, this warning light comes on on the centre console panel.

It is accompanied by an audible signal for a few seconds if the passenger has not fastened his seat belt.

If the seat belt is unfastened **while the vehicle is moving**, you are alerted by the same warnings.

Rear seat belts

Each rear seat is fitted with a three-point inertia reel seat belt with force limiter.

Fastening

- ☞ Pull the strap, then insert the tongue in the buckle.
- ☞ Check that the seat belt is fastened correctly by pulling the strap.

Unfastening

- ☞ Press the red button on the buckle.

Storing after use

Rear side seat belts

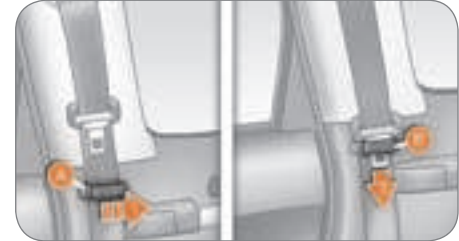

1. Pass the seat belt under the support **A** located on each rear side pillar,
2. Insert the tongue in the slot **B** of the support.

Rear buckles



- ☞ Store the buckles in the locations **A** and **B** provided for this purpose in the rear seat cushion.



Wherever you are seated in the vehicle, always fasten your seat belt, even for short journeys.

Do not invert the seat belt buckles as they will not fulfil their role fully.

The seat belts are fitted with an inertia reel permitting automatic adjustment of the length of the strap to your size. The seat belt is stored automatically when not in use.

Before and after use, ensure that the seat belt is rolled up correctly.

The lower part of the strap must be positioned as low as possible on the pelvis.

The upper part must be positioned in the hollow of the shoulder.

The inertia reels are fitted with an automatic locking device which comes into operation in the event of a collision, emergency braking or if the vehicle rolls over. You can release the device by pulling rapidly on the strap and releasing it.

In order to be effective, a seat belt:

- must be tightened as close to the body as possible,
- must restrain one person of adult size only,
- must not bear any trace of cuts or fraying,
- must be pulled in front of you with a smooth movement, checking that it does not twist,
- must not be transformed or modified to avoid altering its performance.

In accordance with current safety regulations, all repairs and checks must be carried out by a CITROËN dealer who guarantees that the work is carried out correctly.

Have your seat belts checked regularly by a CITROËN dealer and particularly if the straps show signs of damage.

Clean the seat belt straps with soapy water or a textile cleaning product, sold by CITROËN dealers.

After folding or moving a seat or rear bench seat, ensure that the seat belt is positioned and rolled up correctly.

Recommendations for children

Use a suitable child seat if the passenger is less than 12 years old or shorter than one metre fifty.

Never use the same seat belt to secure more than one person.

Never allow a child to travel on your lap.

Depending on the nature and seriousness of the impacts,

the pre-tensioning device may be triggered before and independently of the air bags. Triggering of the pre-tensioners is accompanied by a slight discharge of harmless smoke and a noise, due to the activation of the pyrotechnic cartridge incorporated in the system.

In all cases, the air bag warning light comes on.

Following an impact, have the seat belts system checked, and if necessary replaced, by a CITROËN dealer.

AIR BAGS

System designed to maximise the safety of the occupants (with the exception of the rear centre passenger) in the event of violent collisions. It supplements the action of the force-limiting seat belts.

If a collision occurs, the electronic detectors record and analyse the front and side impacts sustained in the impact detection zones:

- in the case of a serious impact, the air bags are triggered instantly and protect the occupants of the vehicle (with the exception of the rear centre passenger); immediately after the impact, the air bags deflate rapidly so that they do not hinder visibility or the exit of the occupants,
- in the case of a minor or rear impact or in certain roll-over conditions, the air bags will not be triggered; the seat belt alone is sufficient to provide optimum protection in these situations.



The air bags do not operate when the ignition is switched off.

This equipment will only operate once. If a second impact occurs (during the same or a subsequent accident), the air bag will not operate.

Impact detection zones



- A.** Front impact zone.
- B.** Side impact zone.

Triggering of the air bag(s) is accompanied by a slight emission of harmless smoke and a noise, due to the activation of the pyrotechnic cartridge incorporated in the system.

This smoke is not harmful, but sensitive individuals may experience slight irritation.

The noise of the detonation may result in a slight loss of hearing for a short time.

Front air bags

System which protects the head and chest of the driver and front passenger in the event of a front impact.

The driver's air bag is incorporated in the centre of the steering wheel; the front passenger's air bag is incorporated in the fascia above the glove box.

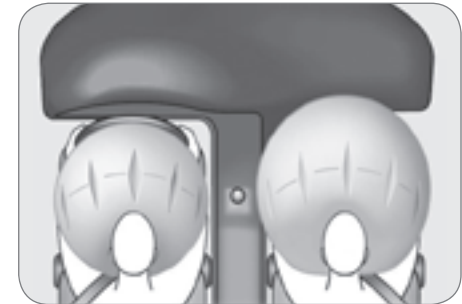

Activation

The air bags are triggered simultaneously, unless the passenger's front air bag is disarmed, in the event of a serious front impact applied to all or part of the front impact zone **A**, in the longitudinal centreline of the vehicle on a horizontal plane and directed from the front to the rear of the vehicle.

The front air bag inflates between the front occupant of the vehicle and the fascia to cushion his forward movement.

Deactivation

Only the front passenger's air bag can be disarmed:

- ☞ **with the ignition off**, insert the key in the passenger air bag disarming switch **A**,
- ☞ turn it to the **"OFF"** position,
- ☞ remove the key.



VI



This warning light comes on on the centre console front panel when the ignition is on and until the air bag is re-armed.



To guarantee the safety of your child, it is imperative that the passenger air bag is disarmed when you install a "rear facing" child seat on the front passenger seat. Otherwise, the child would risk being seriously injured or killed if the air bag were triggered.

Reactivation

When you remove the child seat, turn switch **A** to the **"ON"** position to re-arm the air bag and so guarantee the safety of your front passenger in the event of an impact.

The associated warning light switches off.

Operating fault



If this warning light comes on on the instrument panel and this display appears on the instrument panel display, contact a CITROËN dealer to have the system checked. The air bags may no longer be triggered in the event of a serious impact.



If the air bag warning light and the display come on continuously, do not install a "rear facing" child seat on the front passenger seat. Consult a CITROËN dealer.

Side air bags

System which protects the driver and passenger in the event of a serious side impact in order to limit the risk of injury to the chest.

Each side air bag is incorporated in the front seat back frame, on the door side.



Activation

The side air bag is triggered unilaterally in the event of a serious side impact applied to all or part of the side impact zone **B**, perpendicular to the longitudinal centreline of the vehicle on a horizontal plane and directed from the outside towards the inside of the vehicle.

The side air bag inflates between the front occupant of the vehicle and the corresponding door trim pad.

Impact detection zones



- A. Front impact zone.
- B. Side impact zone.

Curtain air bags

System which protects the driver and passengers (with the exception of the rear centre passenger and the passengers of row 3) in the event of a serious side impact in order to limit the risk of injury to the head.

Each curtain air bag is incorporated in the pillars and the upper section of the passenger compartment.



Activation

The curtain air bag is triggered at the same time as the corresponding side air bag in the event of a serious side impact applied to all or part of the side impact zone **B**, perpendicular to the longitudinal centreline of the vehicle on a horizontal plane and directed from the outside towards the inside of the vehicle.

The curtain air bag inflates between the front or rear occupant of the vehicle and the windows.



In the event of a minor impact or bump on the side of the vehicle or if the vehicle rolls over, the air bag may not be triggered.

In the event of a rear or front collision, the air bag is not triggered.

Operating fault



If this warning light comes on in the instrument panel and this display appears on the instrument panel display, contact a CITROËN dealer to have the system checked. The air bags may no longer be triggered in the event of a serious impact.



For the air bags to be fully effective, observe the following safety rules:

Sit in a normal upright position.

Wear a correctly adjusted seat belt.

Do not leave anything between the occupants and the air bags (a child, pet, object...). This could hamper the operation of the air bags or injure the occupants.

After an accident or if the vehicle has been stolen or broken into, have the air bag systems checked.

All work on the air bag system is strictly forbidden unless it is carried out by qualified personnel of the CITROËN network.

Even if all of the precautions mentioned are observed, a risk of injury or of minor burns to the head, chest or arms when an air bag is triggered cannot be ruled out. In fact, the bag inflates almost instantly (within a few milliseconds) then deflates within the same time discharging the hot gas via openings provided for this purpose.

Front air bags

Do not drive holding the steering wheel by its spokes or resting your hands on the centre part of the wheel.

Passengers must not place their feet on the fascia.

Smoke as little as possible as deployment of the air bags can cause burns or the risk of injury from a cigarette or pipe.

Never remove or pierce the steering wheel or hit it violently.

Side air bags

Put approved covers only on the seats. These will not hinder inflation of the side air bags. Consult a CITROËN dealer.

Do not fix or glue anything to the seat backs. This could cause injury to the chest or arms if the side air bag is triggered.

Do not sit with the upper part of the body any nearer to the door than necessary.

Curtain air bags

Do not fix or glue anything to the roof. This could cause injury to the head if the curtain air bag is triggered.

Do not remove the grab handles installed on the roof, they play a part in securing the curtain air bags.

HANDBRAKE

Mechanical brake to hold the vehicle when stationary.

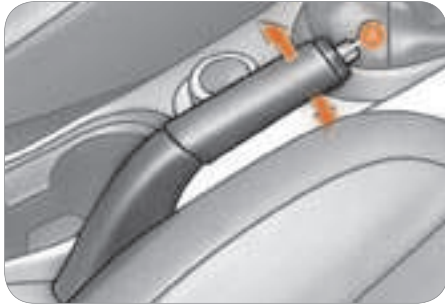

Applying

☞ Pull the handbrake to immobilise your vehicle.

When parking on a slope, direct your wheels towards the pavement and apply the handbrake.

Releasing

☞ Pull on the handle and press the button **A** to release the handbrake.



When the vehicle is being driven, the displaying of this screen indicates that the handbrake is still on or has not been properly released.

6-SPEED MANUAL GEARBOX

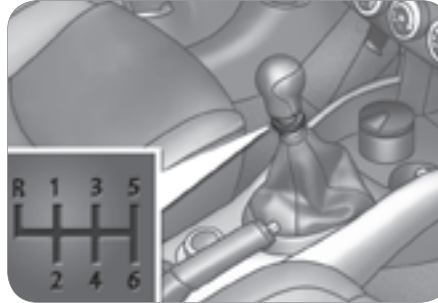

Reverse

To change to reverse gear, lift the ring under the gear lever knob and push the gear lever to the left then to the front.

Reverse gear can only be engaged when the vehicle is stationary with the engine idling.

“CVT” GEARBOX

The six-speed automatic gearbox offers a choice between the comfort of automatic regulation or the pleasure of manual gear changing.

This gearbox enables you to access two driving modes:

- an automated mode for automatic control of the gears by the gearbox and therefore without any action on the part of the driver,
- a sequential mode for manual changing of the gears by the driver using the steering wheel controls or the gear lever.



It consists of the following controls:

- a gear lever **1** on the centre console for selecting the driving mode, reverse gear and neutral or for changing gear in sequential mode,

HANDBRAKE

Mechanical brake to hold the vehicle when stationary.

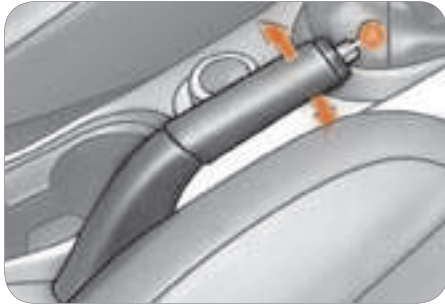

Applying

☞ Pull the handbrake to immobilise your vehicle.

When parking on a slope, direct your wheels towards the pavement and apply the handbrake.

Releasing

☞ Pull on the handle and press the button **A** to release the handbrake.



When the vehicle is being driven, the displaying of this screen indicates that the handbrake is still on or has not been properly released.

6-SPEED MANUAL GEARBOX

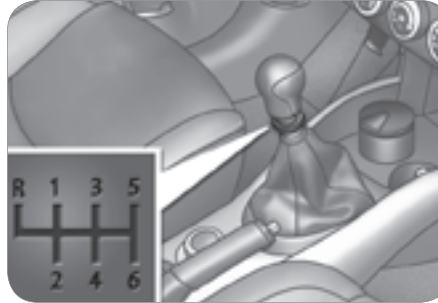

Reverse

To change to reverse gear, lift the ring under the gear lever knob and push the gear lever to the left then to the front.

Reverse gear can only be engaged when the vehicle is stationary with the engine idling.

“CVT” GEARBOX

The six-speed automatic gearbox offers a choice between the comfort of automatic regulation or the pleasure of manual gear changing.

This gearbox enables you to access two driving modes:

- an automated mode for automatic control of the gears by the gearbox and therefore without any action on the part of the driver,
- a sequential mode for manual changing of the gears by the driver using the steering wheel controls or the gear lever.



It consists of the following controls:

- a gear lever **1** on the centre console for selecting the driving mode, reverse gear and neutral or for changing gear in sequential mode,



- a “-” steering wheel control **2** for sequential downward gear changes,
- a “+” steering wheel control **3** for sequential upward gear changes.

Gear lever positions

N: neutral.

With your foot on the brake, select this position to start.

R: reverse gear.

With the vehicle stationary, keep your foot on the brake pedal and push the gear lever upwards.

D: automated mode.

Move the lever downwards to select this mode.

+/-: sequential mode with manual gear changing.

Move the lever downwards, then to the left to select this mode, then:

- push forward to change up,
- push rearward to change down.

Functions of the steering wheel controls

+: manual gear changing in sequential mode.

Press behind the “+” steering wheel control to change up.

-: manual gear changing in sequential mode.

Press behind the “-” steering wheel control to change down.

Moving off

Select position **N**.



 **Press the brake pedal firmly while starting the engine.**

Start the engine. “**N**” appears on the instrument panel display.

Select first gear (position **D** or **+/-**) or reverse (position **R**).

Release the handbrake.

Release the brake pedal then accelerate.

“**D**” or “**1**” or “**R**” appear on the instrument panel display.

Stopping - Starting on a slope

Do not use the accelerator pedal to immobilise the vehicle on a slope, apply the handbrake instead.

When starting on a slope, accelerate gradually while releasing the handbrake.

Switching to sequential mode

Once you have moved off, you can switch to sequential mode by selecting position **+/-**.

“**D**” disappears and the gears engaged appear in succession on the instrument panel display.

The gear change requests are only carried out if the engine speed permits it.

Take your foot off the accelerator pedal gently to engage the gear.

At low speeds, when approaching a stop or traffic lights for example, the gearbox changes down to first gear automatically.

Switching to automated mode

Automated mode

After using the sequential mode, you can return to the automated mode by selecting position **D**.

“**D**” appears on the instrument panel display.

The gearbox then operates in auto-active mode, without any action on the part of the driver.

It continuously selects the gear most suited to the following parameters:

- driving style,
- road characteristics,
- vehicle load.

To optimise driving comfort and obtain the most suitable gear, avoid sharp variations in the pressure on the accelerator pedal.

“Auto sequential” mode

In the automated mode, you can resume control temporarily at any time using the steering wheel controls.

The use of these controls permits manual selection of the gears in situations which require a faster changedown than that offered in automated mode (arrival at a roundabout, exit from a car park with a steep gradient, overtaking...).

The gearbox engages the gear requested if the engine speed permits it. The gear engaged appears.

To return to the automated mode, press the back of the “**+ / OFF**” control for approximately 2 seconds.

Stopping the vehicle

Before switching off the engine, you can:

- move to position **N** to leave the gearbox in neutral.
- leave a gear engaged, such as first or reverse.

In both cases, it is imperative that you apply the handbrake to immobilise the vehicle.

Operating anomaly

With the ignition on, if the message “**Slow down**” or “**Maintenance required**” appears on the multifunction display, this indicates a gearbox malfunction.

When a message is displayed, carry out the following operations:

- slow down and stop your vehicle in a safe place,
- place the lever in position **N** and let the engine run,
- open the bonnet to allow the engine to cool.

If the message disappears for a long period, you can set off again.

If the message remains displayed or appears frequently, contact a CITROËN dealer without delay.

FOUR WHEEL DRIVE SYSTEM WITH ELECTRONIC CONTROL

System which permits the selection of a transmission mode in relation to the driving conditions.

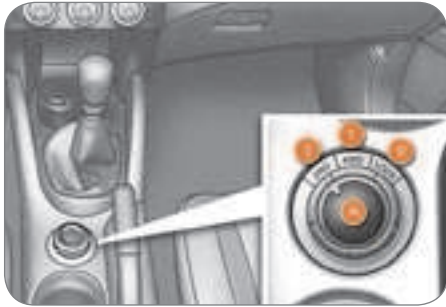

VII

Three transmission modes are available and can be selected manually by the driver in accordance with his requirements.

You can change transmission mode when stationary or while driving at a speed **below 60 mph (100 km/h)**.

The transmission mode can be selected by turning the control **A**.

Selecting the transmission mode

4WD AUTO (position 1)

The vehicle operates with four wheel drive and provides optimum traction regardless of the level of grip.

This is the vehicle's normal and regular operating mode, the distribution of the torque between the front and rear axles is controlled automatically.

The distribution favours the front wheels, the transfer of torque to the rear wheels is managed electronically by the control unit in relation to the level of grip, so guaranteeing optimum road holding.

4WD LOCK (position 2)

The vehicle operates with four wheel drive in this mode also.

It is recommended when grip is particularly poor or difficult (sand, mud, slopes, ...).

2WD (position 3)

The vehicle operates with front two wheel drive.

This mode corresponds to use on a tarmacked road on which the driver considers that there is no risk of loss of grip (dry road).

The selection of this mode is recommended when the level of grip permits.

Display on the instrument panel



The transmission mode is displayed in the form of an intermittent display on the instrument panel display when the transmission mode is selected.

Operating faults



If the selected transmission mode display flashes, the vehicle switches automatically to front “2WD” transmission mode.

It is then no longer possible to select the transmission mode using the control **A**.

If the message “SLOW DOWN” is displayed on the instrument panel, let the transmission cool down then wait for the display to clear before setting off again.

If “4WD” and “LOCK” are displayed alternately and if “MAINTENANCE REQUIRED” is displayed on the instrument panel, the system has failed and the safety system has been activated.

Contact a CITROËN dealer without delay.



Do not subject the vehicle to excessive conditions while driving.

As the engine torque is applied to all four wheels, the condition of the tyres has a considerable impact on the performance of the vehicle.

Ensure that all four tyres are in good condition.

Avoid driving the vehicle in sandy or muddy areas or in other areas in which the wheels could spin.

Spinning the wheels places the transmission components under pressure and could cause a serious malfunction.

Do not drive the vehicle through deep water.

Avoid driving over excessively uneven terrain (risk of scraping under the body or of grounding on crossing a bridge).



Have your vehicle towed on a flatbed.

The vehicle must not be towed with the front or rear wheels on the ground even if it is in front “2WD” (2 wheel drive) mode.

CRUISE CONTROL

System which permits automatic maintaining of the vehicle speed at the value programmed by the driver, without any action on the accelerator pedal.

The **cruise control** is switched on manually: the vehicle speed must be 25 mph (40 km/h) minimum and second gear must be engaged in the case of a manual gearbox.

The **cruise control** is switched off manually, by an action on the brake or clutch pedal or if the ASC system is triggered.

The programmed speed can be exceeded temporarily by pressing the accelerator pedal.

To return to the programmed speed, simply release the accelerator pedal.

Switching off the ignition cancels any programmed speed value.

The cruise control cannot, in any circumstances, take the place of the need to comply with speed limits or of the vigilance and responsibility of the driver.

Steering wheel controls



The controls of this system are grouped together on the steering wheel.

1. **“ON/OFF”** button: activation / deactivation of the cruise control mode.
2. **“COAST SET”** button: storing of a driving speed and decreasing of the cruising speed.
3. **“ACC RES”** button: increasing of the cruising speed and recalling of the stored speed.
4. **“CANCEL”** button: switching off of the cruise control.

Display on the instrument panel



When you press button 1, **“CRUISE”** indicator light comes on on the instrument panel.

Programming

- ☞ Press button 1.
- ☞ Set the programmed speed by accelerating to the required speed, then press button 2 **“COAST SET”**.

Increasing the programmed speed

- ☞ Using button **3** “**ACC RES**”:
 - successive presses increase the speed in steps of approximately 1 mph (1.6 km/h).
 - a maintained press of this button increases the programmed speed progressively.

Once the speed required has been reached, release the button, the new speed is stored.

- ☞ Using the accelerator pedal:
 - accelerate to reach the speed required, then press button **2** “**COAST SET**”. Release the button to store the new speed.

Decreasing the programmed speed

- ☞ Using button **2** “**COAST SET**”:
 - successive presses decrease the speed in steps of approximately 1 mph (1.6 km/h).
 - a maintained press of this button decreases the speed progressively.

Once the speed required has been reached, release the button, the new speed is stored.

- ☞ Using the brake pedal:
 - brake to deactivate the cruise control, then press button **2** “**COAST SET**”. Release to store the new speed.

Temporary acceleration/ deceleration

Temporary acceleration

Press the accelerator pedal as normal. When the pedal is released, you return to the stored speed.

Temporary deceleration

Press the brake pedal to reduce the speed. To return to the stored speed, press button **3** “**ACC RES**”.

Deactivating the function

To deactivate the cruise control:

- ☞ Press the **brake** or **clutch** pedal, or
- ☞ Press button **1** “**ON OFF**”, or
- ☞ Press button **4** “**CANCEL**”.

The cruise control may be deactivated automatically:

- ☞ When the vehicle reaches a speed below 20 mph (35 km/h).
- ☞ When the active stability control system (ASC) comes into operation.

Reactivating the function

When the cruise control has been deactivated, you can return to the stored speed by pressing button **3** “**ACC RES**” when you reach a minimum speed of 25 mph (40 km/h).



When the cruise control is in operation, pay attention if you press and hold one of the programmed speed adjustment buttons: this can result in a very rapid change in the speed of your vehicle. Do not use the cruise control on slippery roads or in heavy traffic.

On a steep descent, the cruise control will not be able to prevent the vehicle from exceeding the programmed speed.

To prevent the mat from becoming caught under the pedals:

- ensure that the mat is positioned correctly,
- never fit one mat on top of another.

AUDIBLE REAR PARKING ASSISTANCE

System consisting of proximity sensors, installed in the rear bumper.



It detects any obstacle (person, vehicle, tree, gate,...) located behind the vehicle, but it cannot detect obstacles located immediately below the bumper.

Location of the sensors

The vehicle is fitted with four sensors:

- two side sensors **A**
- two central sensors **B**.

An object such as a stake, a road works cone or any other similar object may be detected at the beginning of the manoeuvre but may no longer be detected when the vehicle moves closer to it.

Detection zones

The detection zones differ according to the vehicle's equipment, with or without towbar.

Therefore, you can select the towbar mode, the fitting zone **C** is excluded from the detection zones.

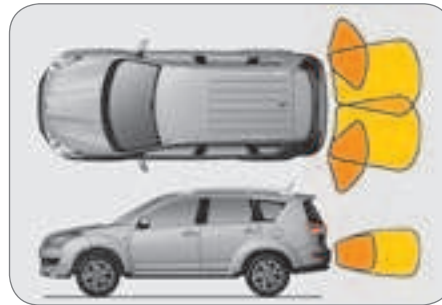

Vehicle only

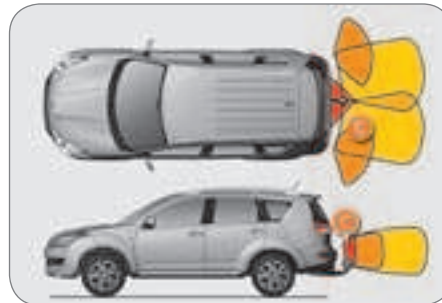

Vehicle fitted with a towbar

Activation

The parking assistance is activated by engaging reverse gear.

The proximity information is indicated by an audible signal which becomes more frequent as the vehicle approaches the obstacle.

When a certain distance between the rear of the vehicle and the obstacle is reached, the audible signal becomes continuous:

Sensors	Distance between vehicle and obstacle less than:
Side A	Approximately 25 cm
Central B without towbar	Approximately 40 cm
Central B with towbar	Approximately 60 cm

The parking assistance system cannot, in any circumstances, take the place of the need for vigilance and responsibility on the part of the driver.

Modification of the detection zones

- ☞ Press button **A** to deactivate the system.
- ☞ Press button **A** again for a few seconds and release it.

The detection zone modification information is indicated by an audible signal which:

- is heard **twice** on vehicles fitted with a towbar,
- is heard **once** on vehicles which are not fitted with a towbar.

Deactivation



- ☞ With reverse gear engaged, press button **A**, the indicator light switches off, the system is fully deactivated.

Reactivation

- ☞ With reverse gear engaged, press button **A** again, the indicator light comes on, the system is reactivated.

Operating fault

If an operating fault occurs, the indicator light on button **A** flashes when reverse gear is engaged.

Consult a CITROËN dealer.

In bad weather or in winter, check that the sensors are not covered with mud, ice or snow.

REVERSING CAMERA



Linked with the navigation option, a reversing camera is activated automatically when reverse gear is engaged.

The colour visual return is provided on the navigation display with indication of the limit of the rear bumper and of the general direction of the vehicle.

The red line indicates the distance required to open the lower tailgate.

Modification of the detection zones

- ☞ Press button **A** to deactivate the system.
- ☞ Press button **A** again for a few seconds and release it.

The detection zone modification information is indicated by an audible signal which:

- is heard **twice** on vehicles fitted with a towbar,
- is heard **once** on vehicles which are not fitted with a towbar.

Deactivation



- ☞ With reverse gear engaged, press button **A**, the indicator light switches off, the system is fully deactivated.

Reactivation

- ☞ With reverse gear engaged, press button **A** again, the indicator light comes on, the system is reactivated.

Operating fault

If an operating fault occurs, the indicator light on button **A** flashes when reverse gear is engaged.

Consult a CITROËN dealer.

In bad weather or in winter, check that the sensors are not covered with mud, ice or snow.

REVERSING CAMERA



Linked with the navigation option, a reversing camera is activated automatically when reverse gear is engaged.

The colour visual return is provided on the navigation display with indication of the limit of the rear bumper and of the general direction of the vehicle.

The red line indicates the distance required to open the lower tailgate.

OPENING THE BONNET

Protection system which also provides access for checking the various levels of the engine components.

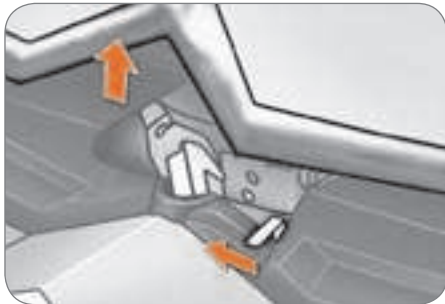

From inside: pull the handle A, on the left-hand side below the door, towards you.

From outside: move the catch to the left then raise the bonnet.

Bonnet strut



Secure the strut in its housing to hold the bonnet open.

Before closing the bonnet, replace the strut in its clip.

To close

Lower the bonnet and release it at the end of its travel. Check that the bonnet is properly locked.

RUNNING OUT OF FUEL

If you run out of fuel, fill the tank and operate the starter until the engine starts. Several attempts must be made before the engine re-starts.

CHECKS

PETROL ENGINE

This allows you access to check the level of the various fluids and replace certain components.

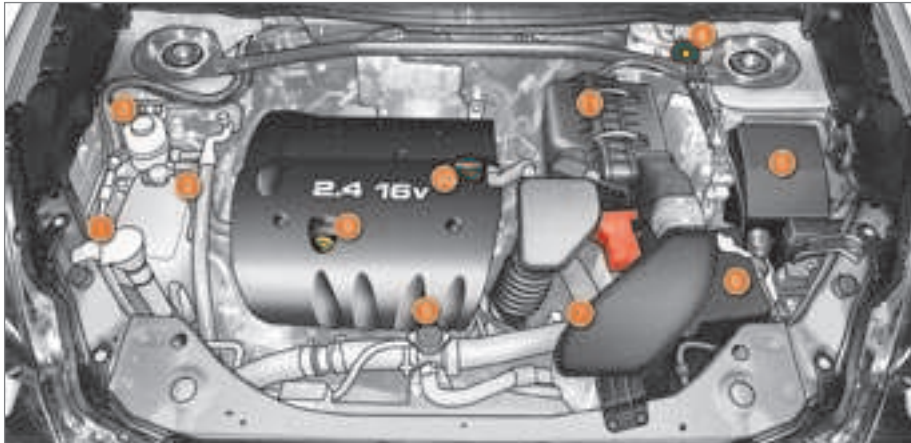

1. Wash-wipe and headlamp wash reservoir.
2. Coolant reservoir.
3. Power steering fluid reservoir.
4. Brake fluid reservoir.
5. Fuse box.
6. Battery.
7. "CVT" gearbox gauge.
8. Radiator cap.
9. Dipstick.
10. Engine oil filler cap.
11. Air filter.

DIESEL ENGINE

This allows you access to check the level of the various fluids and replace certain components.

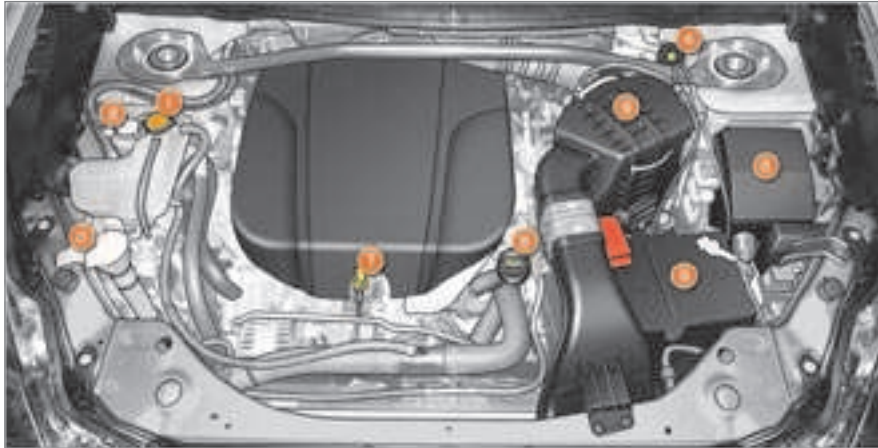

1. Coolant reservoir.
2. Power steering fluid reservoir.
3. Wash-wipe and headlamp wash reservoir.
4. Brake fluid reservoir.
5. Fuse box.
6. Battery.
7. Dipstick.
8. Engine oil filler cap.
9. Air filter.

CHECKING LEVELS

Check all of these levels regularly and top them up if necessary, unless otherwise indicated.

If a level drops significantly, have the corresponding circuit checked by a CITROËN dealer.

Oil level



The reading will only be correct if the vehicle is on level ground and the engine has been off for more than 15 minutes.

The check is carried out either when the ignition is switched on using the oil level indicator on the instrument panel, or using the dipstick.

Between two oil changes, the consumption should not exceed 0.5 litre per 600 miles (1,000 km).

Draining the engine

Refer to the servicing booklet for details of the interval for this operation.

In order to maintain the reliability of the engine and emission control system, the use of additives in the engine oil is prohibited.

Oil specification

The oil must correspond to your engine and conform to the manufacturer's recommendations.

Brake fluid level



The brake fluid level should be between the "MAX" and "MIN" marks.

If it is not, check the brake pad wear.

Draining the circuit

Refer to the servicing booklet for details of the interval for this operation.

Fluid specification

The brake fluid must conform to the manufacturer's recommendations and fulfil the DOT4 standards.

Coolant level



The coolant level must be measured when the engine is cold and should be between the "LOW" and "FULL" marks.

When the engine is warm, the temperature of the coolant is regulated by the fan. This can operate with the ignition off.

On vehicles which are fitted with a particle emission filter, the fan may operate after the vehicle has been switched off, even if the engine is cold.

In addition, as the cooling system is pressurised, wait at least one hour after switching off the engine before carrying out any work.

To avoid any risk of scalding, unscrew the cap by two turns to allow the pressure to drop. When the pressure has dropped, remove the cap and top up the level.

Draining the circuit

Refer to the servicing booklet for details of the interval for this operation.

Fluid specification

The coolant must conform to the manufacturer's recommendations.

Wash-wipe and headlamp wash* fluid



Check the fluid level regularly, using the gauge.

Fluid specification

This fluid must conform to the manufacturer's recommendations for optimum cleaning.

Power steering fluid level

Check the fluid level with the engine at idle.

Check that the power steering fluid level is always between the "MAX" and "MIN" marks and top up if necessary.

Fluid specification

This fluid must conform to the manufacturer's recommendations.

*According to country.

Diesel additive level (Diesel with particle emission filter)

The minimum level of this additive is indicated by lighting of the service warning light, accompanied by an audible signal and a message on the multifunction display.

Topping up

It is imperative that this additive is topped up by a CITROËN dealer without delay.

Used products



Avoid any prolonged contact of used oil or fluids with the skin. Most of these fluids are harmful to health or indeed very corrosive.

VIII

Do not discard used oil or fluids into sewers or onto the ground.

Empty used oil into the containers provided for this purpose in the CITROËN network.

CHECKS

Unless otherwise indicated, check these components in accordance with the servicing booklet and in relation to your engine.

Otherwise, have them checked by a CITROËN dealer.

Battery



Check the electrolyte level regularly. If necessary, top up the level with distilled water.

Check that the terminals are clean and correctly tightened, particularly in summer and winter.

When carrying out work on the battery, refer to the "Practical information" section for details of the precautions to be taken before disconnecting the battery and following its reconnection.

Air filter and passenger compartment filter



Refer to the servicing booklet for details of the replacement intervals for these components.

Depending on the environment (dusty atmosphere...) and the use of the vehicle (city driving...), replace them twice as often if necessary (refer to the "Engines" paragraph).

A clogged passenger compartment filter may have an adverse effect on the performance of the air conditioning system and generate undesirable odours.

Particle emission filter (Diesel)

It is imperative that the maintenance of the particle emission filter is carried out by a CITROËN dealer.

Following prolonged operation of the vehicle at very low speed or at idle, you may, exceptionally, notice the emission of water vapour at the exhaust on acceleration. This does not have any adverse effect on the performance of the vehicle or on the environment.

Oil filter



Replace the oil filter each time the engine oil is changed.

Refer to the servicing booklet for details of the replacement interval for this component.

Do not discard the oil filter through public channels, deposit it in the containers dedicated to this use in the CITROËN network.

Diesel additive level (Diesel with particle emission filter)

The minimum level of this additive is indicated by lighting of the service warning light, accompanied by an audible signal and a message on the multifunction display.

Topping up

It is imperative that this additive is topped up by a CITROËN dealer without delay.

Used products



Avoid any prolonged contact of used oil or fluids with the skin. Most of these fluids are harmful to health or indeed very corrosive.

VIII

Do not discard used oil or fluids into sewers or onto the ground.

Empty used oil into the containers provided for this purpose in the CITROËN network.

CHECKS

Unless otherwise indicated, check these components in accordance with the servicing booklet and in relation to your engine.

Otherwise, have them checked by a CITROËN dealer.

Battery



Check the electrolyte level regularly. If necessary, top up the level with distilled water.

Check that the terminals are clean and correctly tightened, particularly in summer and winter.

When carrying out work on the battery, refer to the "Practical information" section for details of the precautions to be taken before disconnecting the battery and following its reconnection.

Air filter and passenger compartment filter



Refer to the servicing booklet for details of the replacement intervals for these components.

Depending on the environment (dusty atmosphere...) and the use of the vehicle (city driving...), replace them twice as often if necessary (refer to the "Engines" paragraph).

A clogged passenger compartment filter may have an adverse effect on the performance of the air conditioning system and generate undesirable odours.

Particle emission filter (Diesel)

It is imperative that the maintenance of the particle emission filter is carried out by a CITROËN dealer.

Following prolonged operation of the vehicle at very low speed or at idle, you may, exceptionally, notice the emission of water vapour at the exhaust on acceleration. This does not have any adverse effect on the performance of the vehicle or on the environment.

Oil filter



Replace the oil filter each time the engine oil is changed.

Refer to the servicing booklet for details of the replacement interval for this component.

Do not discard the oil filter through public channels, deposit it in the containers dedicated to this use in the CITROËN network.

Manual gearbox



Refer to the servicing booklet for details of gearbox maintenance.

Transfer box and rear differential



Refer to the servicing booklet for details of the service interval for these components.

Brake pads



Brake wear depends on the style of driving, particularly in the case of vehicles used in town, over short distances. It may be necessary to have the condition of the brakes checked, even between vehicle services.

Unless there is a leak on the circuit, a drop in the brake fluid level indicates that the brake pads are worn.

Brake disc wear status



For any information relating to checking of the brake disc wear status, contact a CITROËN dealer.

Handbrake



If the handbrake travel is too long or if you notice a loss of effectiveness of this system, the handbrake must be adjusted, even between two services.

This system must be checked by a CITROËN dealer.

Only use products recommended by CITROËN or products of equivalent quality and specifications.



In order to optimise the operation of units as important as the braking system, CITROËN selects and offers very specific products.

To avoid damaging the electrical units, the use of a high pressure washer in the engine compartment is strictly prohibited.

CHANGING A WHEEL

Operating procedure for replacing a faulty wheel with the spare wheel using the tools provided with the vehicle.

Access to the tools



The tools are stored in the storage compartment in the boot right-hand trim.

To gain access to them:

- ☞ open the boot,
- ☞ turn button **A** to the left,
- ☞ remove the cover **B**,
- ☞ remove the fixing band **C** and take out the tool bag **D** containing the tools,
- ☞ grip the jack **E** in your hand and remove it from its fixing position.

When storing, take care to secure the tool bag **D** firmly using the fixing band **C**.

List of tools



1. Wheelbrace.
Used to remove the wheel trim and the wheel fixing bolts.
2. Jack.
Used to raise the vehicle.
3. Handle.
Used to extend the jack.



When changing a wheel, ensure that the four wheels are of identical specification and brand.

Other accessories



4. Removable towing eye.
Refer to the "Towing" paragraph.

Wheel with trim

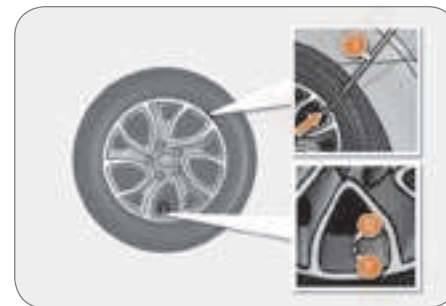

When removing the wheel, remove the trim first using the handle **3**, pulling at the notch.

When refitting the wheel, refit the trim starting by placing its notch **F** (indicated on the back of the trim) opposite the valve **G** and press on its periphery with the palm of your hand.

Access to the spare wheel in the 7 seat configuration



The “space-saving” spare wheel is installed on the outside, under the boot, supported by a metal carrier.

To gain access to the tools, refer to the “Access to the tools” paragraph.

Fixing the “space-saving” spare wheel

If your vehicle is fitted with alloy wheels, it is normal to notice that the washers do not come into contact with the “space-saving” spare wheel when tightening the bolts on fitting. The wheel is retained by the conical contact of each bolt.

Removing the wheel

- ☞ Open the tailgate and the lower tailgate (refer to the “Access” section).
- ☞ Take out the handle **3** (refer to the “Access to the tools” paragraph).



- ☞ Remove the plastic cover **A** using the handle **3**.

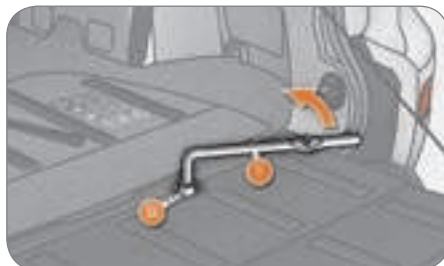

- ☞ Unscrew the spare wheel carrier retaining bolt **B** using the wheel brace **1**.
- ☞ Close the lower tailgate (refer to the “Access” section).
- ☞ Lift the carrier **C** to detach the hook **D** then allow it to lower.



Putting the wheel back in place

- ☞ Put the wheel back in place in the carrier.
- ☞ Lift the carrier **C** and reposition the hook **D**.
- ☞ Open the lower tailgate (refer to the “Access” section).

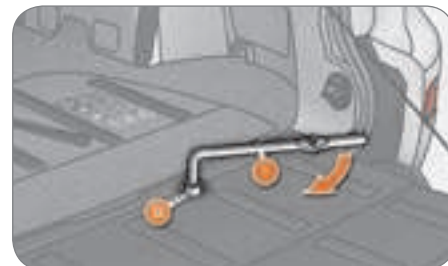

- ☞ Tighten the spare wheel carrier retaining bolt **B** fully using the wheel brace **1**.
- ☞ Refit the plastic cover **A**, close the lower tailgate and store the tools.

Access to the spare wheel in the 5 seat configuration



The “steel” spare wheel is installed on the outside, under the boot, supported by a winch and a plastic carrier.

To gain access to the tools, refer to the “Access to the tools” paragraph.

Fixing the “steel” spare wheel

If your vehicle is fitted with alloy wheels, it is normal to notice that the washers do not come into contact with the “space-saving” spare wheel when tightening the bolts on fitting. The wheel is retained by the conical contact of each bolt.

Removing the wheel

- ☞ Open the tailgate and the lower tailgate (refer to the “Access” section).
- ☞ Take out the handle **3** (refer to the “Access to the tools” paragraph).



- ☞ Remove the plastic cover **A** using the handle **3**.



- ☞ Unscrew the retaining bolt **B** fully using the wheelbrace **1**, to unwind the winch cable.
- ☞ Close the lower tailgate (refer to the “Access” section).
- ☞ Detach the hook **C** from the chain.

Unwind the winch cable fully to make unhooking of the chain easier.



Putting the wheel back in place

- ☞ Put the wheel back in place in the carrier.
- ☞ Pass the hook **C** into the chain.
- ☞ Open the lower tailgate (refer to the “Access” section).



- ☞ Tighten the winch retaining bolt **B** fully using the wheelbrace **1**.
- ☞ Refit the plastic cover **A**, close the lower tailgate and store the tools.

Removing the wheel



Parking the vehicle

Immobilise the vehicle where it does not block traffic: if possible, park the vehicle on level, stable and non-slippery ground.

Apply the handbrake, switch off the ignition and engage first gear to lock the wheels.

If necessary, place a chock under the wheel diagonally opposite the wheel to be changed.

Never go underneath a vehicle raised using a jack; use a stand.

List of operations

- ☞ Fit the anti-theft socket **5** on the wheelbrace **1** to unlock the anti-theft bolt.
- ☞ Unlock the other bolts using the wheelbrace **1** only.

- ☞ Place the jack **2** in contact with one of the two front **A** or rear **B** locations provided on the underframe, whichever is closest to the wheel to be changed.
- ☞ Extend the jack **2** until its base plate is in contact with the ground. Ensure that the centreline of the jack base plate is directly below the location **A** or **B** used.

- ☞ Raise the vehicle until there is sufficient space between the wheel and the ground to admit the spare (not punctured) wheel easily.
- ☞ Remove the bolts and store them in a clean place.
- ☞ Remove the wheel.



Fitting the wheel



List of operations



- ☞ Put the wheel in place on the hub.
- ☞ Screw in the bolts by hand to the stop.
- ☞ Pre-tighten the anti-theft bolt using the wheelbrace 1 fitted with the anti-theft socket 5.
- ☞ Pre-tighten the other bolts using the wheelbrace 1 only.



- ☞ Lock the anti-theft bolt using the wheelbrace 1 fitted with the anti-theft socket 5.
- ☞ Lock the other bolts using the wheelbrace 1 only.
- ☞ Store the tools (refer to the paragraph "Access to the tools").

After changing a wheel

When using the "space-saving" spare wheel, do not exceed a speed of 50 mph (80 km/h).

Have the tightening of the bolts and the pressure of the spare wheel checked by a CITROËN dealer without delay.

Have the punctured wheel repaired and replace it on the vehicle as soon as possible.



- ☞ Lower the vehicle fully.
- ☞ Fold the jack 2 and detach it.

Fitting snow tyres

If you equip your vehicle with snow tyres fitted on steel wheel rims, it is **imperative** that special bolts available from your CITROËN dealer are used.

CHANGING A BULB

Operating procedure for replacing a faulty bulb with a new bulb.

Front lights



1. Direction indicators (PY21W - 21 W).
2. Dipped headlamps (H11 - 55 W) or xenon bulb (D2S - 35 W).
3. Side lights (W5W - 5 W).
4. Main beam headlamps (H7 - 55 W).
5. Front fog lamps (H11 - 55 W).

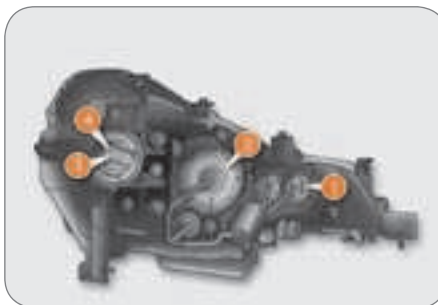

Handle the bulbs using a dry cloth.

Do not clean the headlamps using a dry or abrasive cloth, or using detergent or solvent products, use a sponge and soapy water.



WARNING: RISK OF ELECTROCUTION

Xenon bulbs must be replaced by a CITROËN dealer.

In certain climatic conditions (low temperature, humidity), **the presence of condensation on the inside of the headlamp glass is normal**; it disappears a few minutes after the lights are switched on.

Blown bulb

Refer to the appropriate procedure to change the corresponding bulb.

Changing the direction indicators (1)



- ☞ Turn the bulb holder **A** to the left and remove it.
 - ☞ Pull the bulb and change it.
- To refit, carry out these operations in reverse order.

Access to the bulbs on the left-hand side

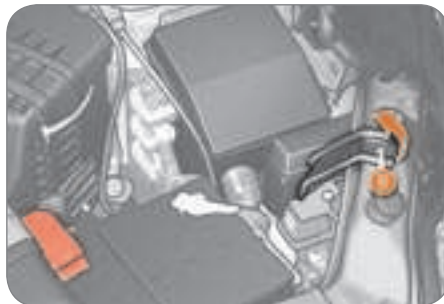

When you change a bulb on the left-hand side, remove the relay box fixing nut **B** and move the relay box towards the rear.

Access to the bulbs on the right-hand side

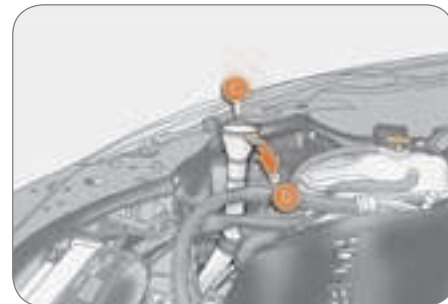

When you change a bulb on the right-hand side:

- ☞ Remove the screenwash reservoir fixing **C** and move the reservoir towards the rear.
- ☞ Remove the coolant reservoir fixing nut **D**.

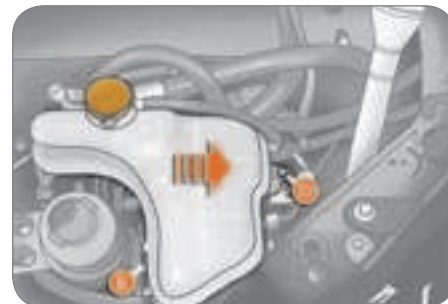

- ☞ Remove the clip **E** and raise the reservoir moving it towards the front.

Coloured bulbs must be replaced with bulbs of identical specification and colour.

Changing the dipped headlamps (2)

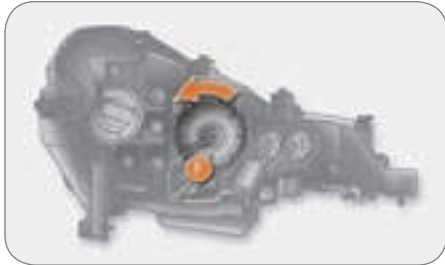

- ☞ Unscrew the cover **F**.
- ☞ Disconnect the connector.



- ☞ Turn the bulb **G** to the left and remove it.
- To refit, carry out these operations in reverse order.

Changing the side lights (3)

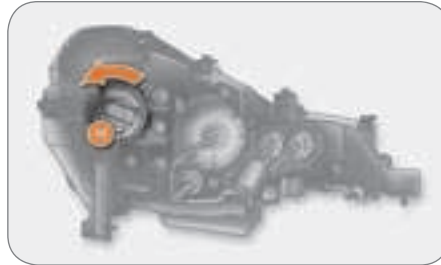

- ☞ Unscrew the cover **H**.
- ☞ Disconnect the connector.



- ☞ Turn the bulb holder **I** a quarter of a turn and remove it.
 - ☞ Pull the bulb and change it.
- To refit, carry out these operations in reverse order.

Changing the main beam headlamps (4)

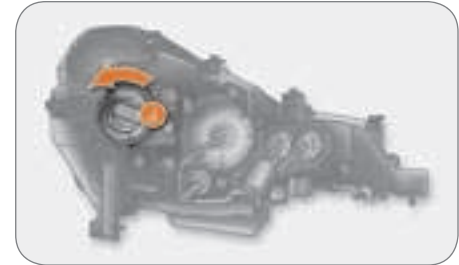

- ☞ Unscrew the cover **J**.
- ☞ Disconnect the connector.



- ☞ Move aside the spring **K** to release the bulb and remove it.
- To refit, carry out these operations in reverse order.

Changing the integrated direction indicator side repeaters



- ☞ Push the repeater **A** towards the rear and detach it.
- ☞ Unclip the repeater.
- ☞ Disconnect the repeater connector and change the repeater.

To refit, carry out these operations in reverse order.

To obtain repeaters, contact a CITROËN dealer.

Changing the fog lamps (5)



- ☞ Turn the wheel fully towards the outside for easy access to the flap **A** located in the wheelarch.



- ☞ Using a screwdriver, remove the four clips **B** located in the wheelarch.



☞ Using a screwdriver, remove the three clips **C** located below the bumper.



☞ Lift the access flap **D** located in the wheel arch and slide it downwards.



☞ Disconnect the connector **E**.
☞ Turn the bulb **F** to the left and remove it.

To refit, carry out these operations in reverse order.

Rear lights



1. Third brake light (diodes).
2. Brake lights / Side lights (21/5 - W21W - 5 W).
3. Direction indicators (WY21W - 21 W).
4. Reversing lights (W21W - 21 W).
5. Number plate lights (W5W - 5W).
6. Fog lamps (W21W - 21 W).

IX

Amber coloured bulbs, such as the direction indicators, must be replaced with bulbs of identical specification and colour.

Changing the third brake light (diodes)

All work on the diode lights must be carried out by a CITROËN dealer.

Changing the brake lights / side lights and direction indicators

These two bulbs are changed from outside with the tailgate open:

- ☞ Open the tailgate (refer to the "Access" section),



- ☞ Remove the two light fixing bolts **A**,
- ☞ Extract the light from outside,

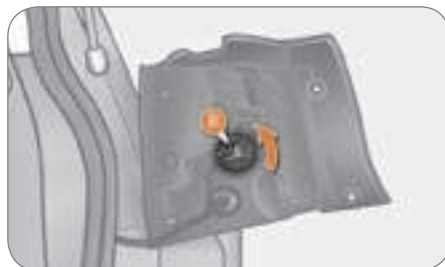

- ☞ Turn the pin **B** to the left and remove it.
- ☞ Pull the bulb and change it.

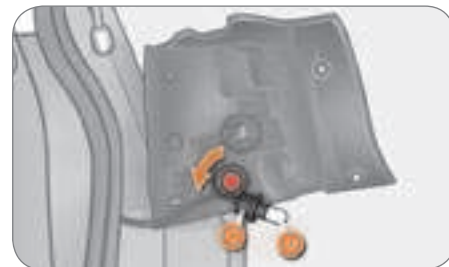

- ☞ Turn the pin **C** to the left and remove it.
- ☞ Pull the bulb **D** and change it.

To refit, carry out these operations in reverse order.

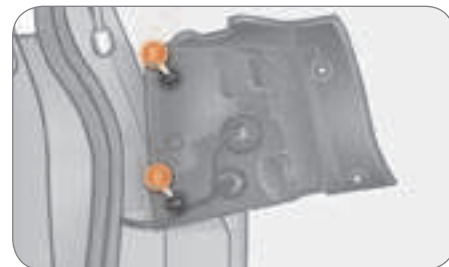

When refitting the light, align the two pins **E** with the openings on the vehicle.

Changing the reversing lights

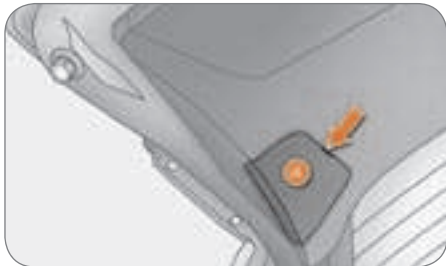

- ☞ Open the tailgate (refer to the “Access” section),
- ☞ From the inside of the tailgate, insert a screwdriver in the opening on the cover **A** to use it as a lever to open the cover.

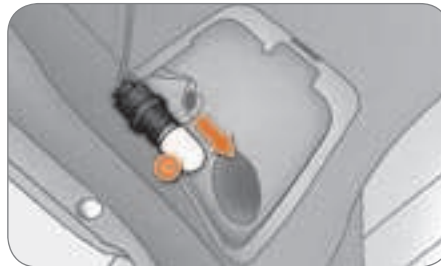

- ☞ Pull the bulb **C** and change it. To refit, carry out these operations in reverse order.



- ☞ Insert a thin screwdriver in the opening on the lens to press the tab **E**.
- ☞ Remove the lens.
- ☞ Pull the bulb and change it. To refit, carry out these operations in reverse order.

Changing the number plate lights



- ☞ Turn the pin **B** to the left and remove it.



- ☞ Open the tailgate (refer to the “Access” section) to gain access to the number plate lights **D**,
- ☞ Remove the light unit **D** while pressing it to the left.



- ☞ To refit the light unit, insert the end of the tab **F** first, then align the tab **G**.

Changing the fog lamps

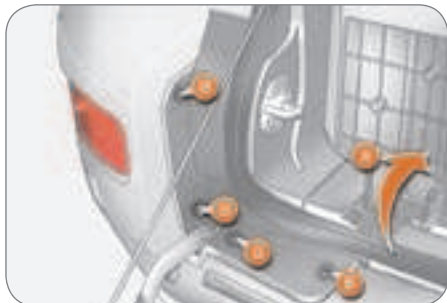

- ☞ Open the tailgate and the lower tailgate (refer to the “Access” section) and fold down the cover **A**.
- ☞ Remove the 4 clips **B** using a screwdriver to detach the light cover.



- ☞ Turn the pin and bulb assembly **D** to the left.
 - ☞ Remove the bulb.
- To refit, carry out these operations in reverse order.



- ☞ Remove the bolts **C** and remove the light unit.



- ☞ When refitting the light unit, align the clips **E** with the openings on the bodywork.

INTERIOR BULBS

Front and rear courtesy lights

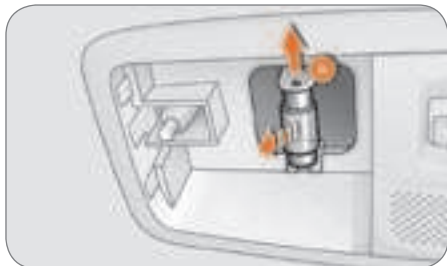

- ☞ Insert a screwdriver to remove the courtesy light cover.
 - ☞ Remove the bulb while pressing the tab **A**.
- To refit the cover, align the hooks on the holes located in the body of the vehicle.

Glove box light



- ☞ Turn the pin **B** anticlockwise and remove it.
- ☞ Remove the bulb.



Low level light

- ☞ Insert a screwdriver to remove the light cover.
- ☞ Remove the bulb.

CHANGING A FUSE

Operating procedure for replacing a faulty fuse with a new fuse to rectify a failure in the corresponding function.



Access to the tools

The extraction pliers are installed in the engine compartment fuse box.

To gain access to them:

- ☞ Open the bonnet (refer to the "Access" section),
- ☞ Press on the hook **A** and release the catch,
- ☞ Remove the cover completely,
- ☞ Remove the pliers **B**.

Changing a fuse

Before changing a fuse, the cause of the failure must be identified and rectified.

- ☞ Identify the faulty fuse by checking the condition of its filament.



Correct



Incorrect

- ☞ Use the special pliers to extract the fuse from its location.
- ☞ Always replace the faulty fuse with a fuse of the same rating.
- ☞ Check the correspondence between the number etched on the box, the rating etched on the top and the tables below.

Your vehicle's electrical system is designed to operate with standard or optional equipment.

Before installing other electrical equipment or accessories in your vehicle, contact a CITROËN dealer.



CITROËN will not accept responsibility for the cost incurred in repairing your vehicle or for rectifying the malfunctions resulting from the installation of accessories not supplied and not recommended by CITROËN and not installed in accordance with its instructions, in particular when the consumption of all of the additional equipment connected exceeds 10 milliamperes.

The spare fuses are located on the engine compartment fuse box cover.

Fascia fuses

The fuse boxes are placed in the lower part of the fascia behind the enclosed storage compartment (left-hand side).



Access to the fuses

- ☞ Open the cover **A**,
- ☞ Pull it towards you to extract it,
- ☞ Change the fuse (refer to the corresponding paragraph).



Fuse N°	Rating	Functions
1*	30 A	Heating.
2	15 A	Brake lights, third brake light, built-in systems interface.
3	10 A	Rear fog lamps.
4	30 A	Windscreen wipers and wash-wipe.
5	10 A	Diagnostic socket.
6	20 A	Central locking, exterior mirrors.
7	15 A	Audio equipment, telematics, multifunction display, hands-free kit, rear DVD player.
8	7.5 A	Remote control key, air conditioning control unit, instrument panel, controls bar, steering wheel controls.
9	15 A	Multifunction display, instrument panel.
10	15 A	Built-in systems interface.
11	15 A	Rear wiper.
12	7.5 A	Instrument panel, 4 wheel drive control unit, air conditioning control panel, ABS control unit, multifunction display, automatic headlamp adjustment, heated seats, air bags control unit, steering wheel angle sensor, sunroof, rear screen demisting, remote control.
13	-	Not used.
14	10 A	Ignition switch.
15	20 A	Sunroof.
16	10 A	Exterior mirrors, audio equipment, telematics, rear DVD player.

PRACTICAL INFORMATION

Access to the fuses

- ☞ Open the cover **A**,
- ☞ Pull it towards you to extract it,
- ☞ Change the fuse (refer to the corresponding paragraph).



Fuse N°	Rating	Functions
17	10 A	4 wheel drive control unit.
18	7.5 A	Reversing lights, parking assistance control unit, reversing camera, air bags control unit.
19	15 A	Accessories socket.
20*	30 A	Electric window controls.
21*	30 A	Rear screen demisting.
22	7.5 A	Heated exterior mirrors.
23	-	Not used.
24	25 A	Driver's electric seat, footwell lighting, releasing of the rear bench seat.
25	30 A	Heated seats.

IX



* The maxi-fuses provide additional protection for the electrical systems. All work on the maxi-fuses must be carried out by a CITROËN dealer.

Engine compartment fuses

The fuse box is placed in the engine compartment near the battery (left-hand side).



Access to the fuses

- ☞ Open the bonnet (refer to the “Access” section),
- ☞ Press on the hook **A** to release the catch,
- ☞ Remove the cover completely,
- ☞ Change the fuse (refer to the corresponding paragraph).
- ☞ When you have finished, close the cover carefully to guarantee the sealing of the fuse box.

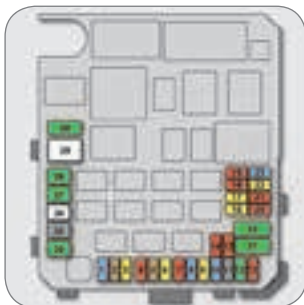

Fuse N°	Rating	Functions
1	15 A	Front fog lamps.
2	7 A	Engine ECU 2.4 litre 16 V
3	20 A	CVT automatic gearbox ECU, relay CVT automatic gearbox ECU
4	10 A	Horn.
5	7.5A	Alternator 2.4 litre 16V
6	20 A	Headlamp wash.
7	10 A	Air conditioning.
8	15 A	Engine ECU 2.4 litre 16 V
9	-	Not used.
10	15 A	Demisting, wipers.
11	-	Not used.
12	-	Not used.
13	-	Not used.
14	10 A	Left-hand main beam headlamp.
15	10 A	Right-hand main beam headlamp.
16	20 A	Left-hand dipped headlamp (xenon).
17	20 A	Right-hand dipped headlamp (xenon).
18	10 A	Left-hand dipped headlamp, manual and automatic headlamp adjustment.
19	10 A	Right-hand dipped headlamp.
20	-	Not used.
21	10 A	Ignition coils

PRACTICAL INFORMATION

Fuse N°	Rating	Functions
22	20 A	Engine control unit, water in diesel detector, injection pump (Diesel), air flow sensor.
23	15 A	Petrol pump, fuel gauge.
24*	30 A	Starter.
25	-	Not used.
26*	40 A	ABS control unit, ASC control unit.
27*	30 A	ABS control unit, ASC control unit.
28*	30 A	Condenser fan.
29*	40 A	Radiator fan.
30	30 A	Passenger compartment fuse box.
31	30 A	Audio amplifier.
32	30 A	Engine control unit



* The maxi-fuses provide additional protection for the electrical systems. All work on the maxi-fuses must be carried out by a CITROËN dealer.

Spare fuses

IX The spare fuses are located under the engine compartment fuse box cover.



Fuse N°	Rating
33	10 A
34	15 A
35	20 A

The cover does not contain spare fuses with an amperage of 7.5 A, 25 A or 30 A. If one of the fuses with these amperages develops a fault, replace it with the following fuse:

A **7.5 A fuse** must be replaced with the **10 A spare fuse**, a **25 A fuse** with a **20 A spare fuse** and a **30 A fuse** with the **audio system fuse (N° 31)**.

BATTERY

Procedure for charging your battery when it is flat or for starting the engine using another battery.

Access to the battery



The battery **A** is located under the bonnet on the left.

To gain access to it:

- ☞ open the bonnet using the interior lever, then the exterior lever,
- ☞ secure the bonnet strut.

Starting using another battery

Looking for an earth point at the right-hand engine mounting

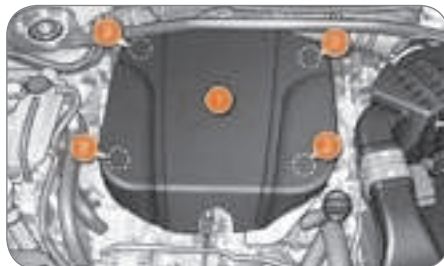

- ☞ Raise the front of the cover **1** to release the three clips **2**.
- ☞ Then pull the cover **1** towards you to release the clip **3** and remove the cover.

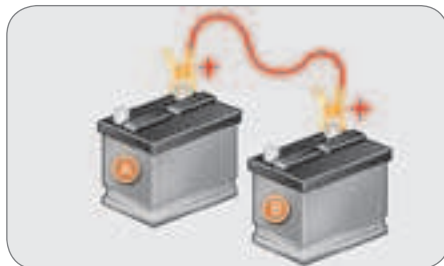

- ☞ Connect the red cable to the positive terminal (+) of the flat battery **A**, then to the positive terminal (+) of the slave battery **B**.

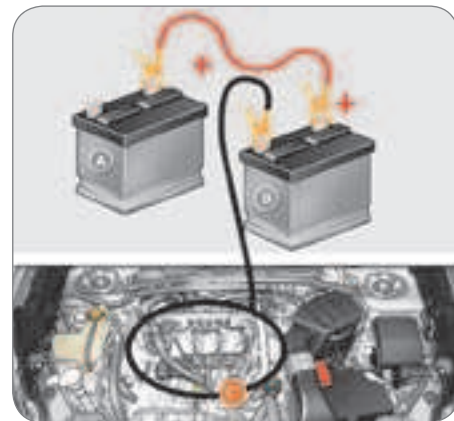

- ☞ Connect one end of the green or black cable to the negative terminal (-) of the slave battery **B**.
- ☞ Connect the other end of the green or black cable to an earth point **C** on the broken down vehicle, as far as possible from the battery (for example, right-hand engine mounting).
- ☞ Start the engine of the assisting vehicle.
- ☞ Operate the starter, let the engine run.
- ☞ Wait until the engine returns to idle and disconnect the cables.

Check the electrolyte level regularly. If necessary, top up the level with distilled water.

Charging the battery using a battery charger

- ☞ Disconnect the battery from the vehicle.
- ☞ Remove the battery and place it in a ventilated area.
- ☞ Remove the top-up caps and top up the level with distilled water if necessary.
- ☞ Connect the battery to the charger observing the instructions for use provided by the manufacturer and start charging.
- ☞ Disconnect the battery from the charger and let it cool.
- ☞ If necessary, top up the level with distilled water.
- ☞ Clean the top of the battery carefully.
- ☞ Put the top-up caps back in place.
- ☞ Check that the terminals and connectors are clean. If they are covered with sulphate (whitish or greenish deposit), remove them and clean them.
- ☞ Reconnect the battery starting with the positive terminal (+).

When charging the battery, it is normal to observe an increase in temperature and bubbling of the electrolyte.

The batteries contain harmful substances such as sulphuric acid and lead. They must be disposed of in accordance with regulations and must not, in any circumstances, be discarded with household waste.

Take used remote control batteries and vehicle batteries to a special collection point.

It is advisable to disconnect the battery if the vehicle is to be left unused for more than one month.



Do not disconnect the terminals while the engine is running.

Do not charge the batteries without disconnecting the terminals first.

Before disconnecting the battery

Wait 2 minutes after switching off the ignition before disconnecting the battery.

Close the windows, the sunroof, the doors and the tailgate before disconnecting the battery.

Following reconnection of the battery

Following reconnection of the battery, switch on the ignition and wait 1 minute before starting to permit initialisation of the electronic systems. However, if slight difficulties are encountered following this operation, contact a CITROËN dealer.

Referring to the corresponding section, you must yourself reinitialise:

- the one-touch electric windows,
- the sunroof,
- the satellite navigation system.



Avoid prolonged contact of the electrolyte with the skin.

Most of these fluids are harmful to health and very corrosive.

CHANGING A WIPER BLADE

Procedure for replacing a worn wiper blade with a new one without the use of tools.

Removing a front or rear wiper blade

- ☞ Raise the corresponding wiper arm.
- ☞ Remove the wiper blade, sliding it towards the outside.

Fitting a front or rear wiper blade

- ☞ At the front, check the size of the wiper blade as the shorter blade is fitted on the right-hand side of the vehicle.
- ☞ Put the corresponding new wiper blade in place and fix it.
- ☞ Fold down the wiper arm carefully.

TOWING

Operating procedure for having your vehicle towed on a flatbed or for towing another vehicle using a removable mechanical device.

Access to the tools



The towing eye and the tools are stored in the storage compartment in the right-hand boot trim.

To access them:

- ☞ open the boot,
- ☞ turn button **A** to the left,
- ☞ remove the cover **B**,
- ☞ remove the fixing band **C** and take out the tool bag **D** containing the tools,
- ☞ take the towing eye and the tools required out of the tool bag.

Having your vehicle towed on a flatbed



- ☞ Below the front bumper, install the towing system on the towing eye **1**.

Place the gear lever in neutral.

! Always have the vehicle towed on a flatbed.

Never have the vehicle towed with the four wheels on the ground, this could damage the transmission.

The vehicle must not be towed with the front or rear wheels on the ground even if it is in front "2WD" (2 wheel drive) mode.

Towing another vehicle

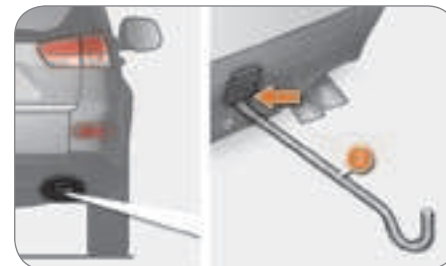

- ☞ On the rear bumper, remove the cover by pulling at the bottom using the jack handle **2**.



- ☞ Screw in the towing eye fully using the wheelbrace **3**.
- ☞ Install the towbar.
- ☞ Switch on the hazard warning lights on the towed vehicle.

! When being towed with the engine off, there is no longer any braking or steering assistance.

TOWING A TRAILER, CARAVAN, ETC.

Towbar suited to the attachment of a trailer or caravan with additional signalling and lighting.



Your vehicle is primarily designed for transporting people and luggage, but it may also be used for towing a trailer.



We recommend the use of original CITROËN towbars and their harnesses that have been tested and approved from the design stage of your vehicle and that the fitting of the towbar is entrusted to a CITROËN dealer.

If the towbar is not fitted by a CITROËN dealer, it is imperative that it is fitted using the electrical pre-equipment located at the rear of the vehicle and in accordance with the manufacturer's instructions.

Driving with a trailer subjects the towing vehicle to more significant stress and its driver must be particularly careful.

Driving advice

Distribution of loads

☞ Distribute the load in the trailer so that the heaviest items are as close as possible to the axle and the nose weight approaches the maximum permitted without exceeding it.

Air density decreases with altitude, thus reducing engine performance. Above 1 000 metres, the maximum towing load must be reduced by 10 % of the GTW and so on for every 1 000 metres of altitude.

Refer to the "Technical Data" section for details of the weights and towing loads which apply to your vehicle.

Side wind

☞ Take into account the increased sensitivity to side wind.

Cooling

Towing a trailer on a slope increases the temperature of the coolant.

As the fan is electrically controlled, its cooling capacity is not dependent on the engine speed.

☞ To lower the engine speed, reduce your speed.

The maximum towing load on a long slope depends on the gradient and the outside temperature.

In all cases, pay attention to the coolant temperature.



☞ If this message is displayed, **stop your vehicle as soon as it is safe to do so.**

If the message flashes slowly, wait for the engine to cool before topping up the level, if necessary.

If the message flashes rapidly, contact a CITROËN dealer without delay.

Braking

Towing a trailer increases the braking distance.

Tyres

☞ Check the tyre pressures of the towing vehicle and of the trailer, observing the recommended pressures.

Lights

☞ Check the electrical signalling on the trailer.



Opening of the lower tailgate is prohibited if a towbar is being used.



FITTING ROOF BARS

Consult a CITROËN dealer for the installation of longitudinal roof bars.

When fitting transverse roof bars, ensure that they are positioned correctly as shown by marks on the longitudinal roof bars.

Use accessories recommended by CITROËN and follow the accessory manufacturer's fitting instructions.

In order to place a load on the roof, your vehicle must be fitted with longitudinal roof bars with transverse roof bars fitted on top of these.

The longitudinal roof bars cannot be removed.

Maximum authorised weight on the roof bars, for a loading height not exceeding 40 cm (except bicycle carriers): 80 kg.

If the height exceeds 40 cm, adapt the speed of the vehicle to the condition of the road, to avoid damaging the roof bars and the fixings on the roof.

Please refer to national legislation to comply with the regulations regarding the transportation of objects which are longer than the vehicle.

TECHNICAL DATA

ENGINE AND GEARBOX

Model code	VUSFZC - VVSFZC	VUSFZF - VVSFZF	U4HNNH - V4HNNH
Engine	2.4 litre 16V		2.2 litre HDI PEF 16V
Cubic capacity (cm ³)	2360		2179
Bore x stroke (mm)	88 x 97		85 x 96
EU standard maximum power (kW)	125		115
Max power engine speed (rpm)	6000		4000
EU standard max torque (Nm)	232		380
Max torque engine speed (rpm)	4100		2000
Fuel	Unleaded		Diesel
Catalytic converter	yes		yes
Particle emission filter (PEF)	no		yes
Gearbox	Manual (5-speed)	CVT (5-speed)	Manual (6-speed)
Oil capacity (in litres) Engine	-		5.25

X

TECHNICAL DATA

CONSUMPTION

In accordance with directive 80/1268/CEE							
Engine	Gearboxes	Model codes	Wheels	Urban driving mpg (litres/100 km)	Inter-urban driving mpg (litres/100 km)	Mixed driving mpg (litres/100 km)	Emission of CO ₂ by weight (g/km) mixed
2.4 litre 16V	Manual (5-speed)	VUSFZC - VVSFZC	-	22.4 (12.6)	37.7 (7.6)	30.1 (9.4)	225
	CVT (6-speed)	VUSFZF - VVSFZF	-	22.4 (12.6)	37.6 (7.5)	30.4 (9.3)	222
2.2 litre HDI PEF 16V	Manual (6-speed)	U4HNNH V4HNNH	16"	29.7 (9.5)	47.9 (5.9)	39.3 (7.2)	191
2.2 litre HDI PEF 16V	Manual (6-speed)	U4HNNH V4HNNH	18"	29.4 (9.6)	47.1 (6.0)	38.7 (7.3)	194

The consumption values presented here correspond to the values communicated at the time of printing.

The consumption values were established in accordance with Directive 80/1268/CEE. They may vary depending on the style of driving, traffic conditions, weather conditions, the load in the vehicle, the maintenance of the vehicle and the use of the accessories.

X

TECHNICAL DATA

WEIGHTS AND TOWED LOADS (IN KG)

Engines	2.4 litre 16V				2.2 litre HDI PEF 16V	
Gearbox	Manual (5-speed)		CVT (5-speed)		Manual (6-speed)	
Model codes	VUSFZC	VVSFZC	VUSFZF	VVSFZF	U4HNH	V4HNH
Version	5 seats	7 seats	5 seats	7 seats	5 seats	7 seats
• Kerb weight*	1650	1685	1680	1715	1790	1825
• Gross vehicle weight (GVW)	2290		2290		2410	
• Gross train weight (GTW)**	3870		3870		4510	
• Unbraked trailer	750		750		750	
• Braked trailer***	1500		1500		2000	
• Recommended nose weight	75		75		100	

*The kerb weight is equal to the weight without load + driver (75 kg).

**The speed of a towing vehicle must not exceed 60 mph (100 km/h) (comply with the legislation in force in your country).

*** The braked trailer value corresponds to the towing capacities of the vehicle on a 12% gradient.

High exterior temperatures may result in a reduction in the performance of the vehicle in order to protect the engine; reduce the towed weight by 450 kg when your altitude increases by 1000 m.

TECHNICAL DATA

DIMENSIONS (IN MM)

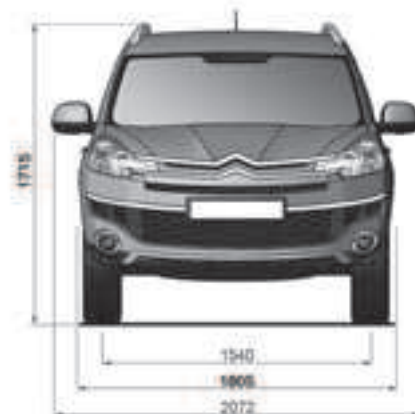

IDENTIFICATION FEATURES



A. Manufacturer's plate.

This number is indicated on a plate riveted on the centre pillar, on the passenger's side.

B. Serial number under the bonnet.

This number is engraved on the bodywork near the windscreen.

C. After Sales plate.

This plate is riveted on the inside of the bonnet.

D. Front number plate.

E. Tyres / paint label.

This label is affixed to the driver's door centre pillar.

It indicates the following information:

- the tyres pressures without load and with load,
- the rim and tyre sizes,
- the pressure of the spare wheel,
- the paint colour reference.

The tyre pressures must be checked when cold at least once a month.

Low tyre pressures increase fuel consumption.

X

YOUR AUDIO-CD SYSTEM



This consists of the following components:

- a control panel,
- a multifunction display,
- steering wheel audio controls,
- 4 or 6 speakers (according to version),
- a CD changer (according to version),
- auxiliary sockets, located at the rear of the centre console (according to version),
- a radio aerial, located on the roof at the rear of the vehicle.

It allows you to:

- listen to the radio in FM/MW/LW,
- listen to audio CDs (CD-DA, CD-Text, CD-R/RW) or CDs with MP3 files.

Steering wheel audio controls



1. **On / Off and selection of the radio or CD mode**
2. **Decreasing of the volume**
3. **Increasing of the volume**
4. **Search for a higher radio frequency / Next track / Fast forwards play**
5. **Search for a lower radio frequency / Previous track / Rewind play**

They can be used when the ignition switch is in the "ON" or "ACC" position.

Switching on

Press button **1** for more than two seconds.

The last source selected before switching off comes back into operation.

Switching off

Press button **1** for more than two seconds.

Selecting the source

Press button **1**.

The source changes in the following order: FM1 / FM2 / FM3 / MW / LW / CD / FM1...

Adjusting the volume

Press and hold button **2** or **3** to decrease or increase the volume respectively.

Searching in radio mode

Press button **4** or **5** to search for a higher or lower radio frequency respectively.

Searching in CD mode

Press button **4** or **5** to select the next or previous track on the CD respectively.

Press and hold button **4** or **5** for fast forwards or rewind playing of the current track of the CD respectively.

While a track is being played, press button **5** once to return to the beginning of this track.

Control panel

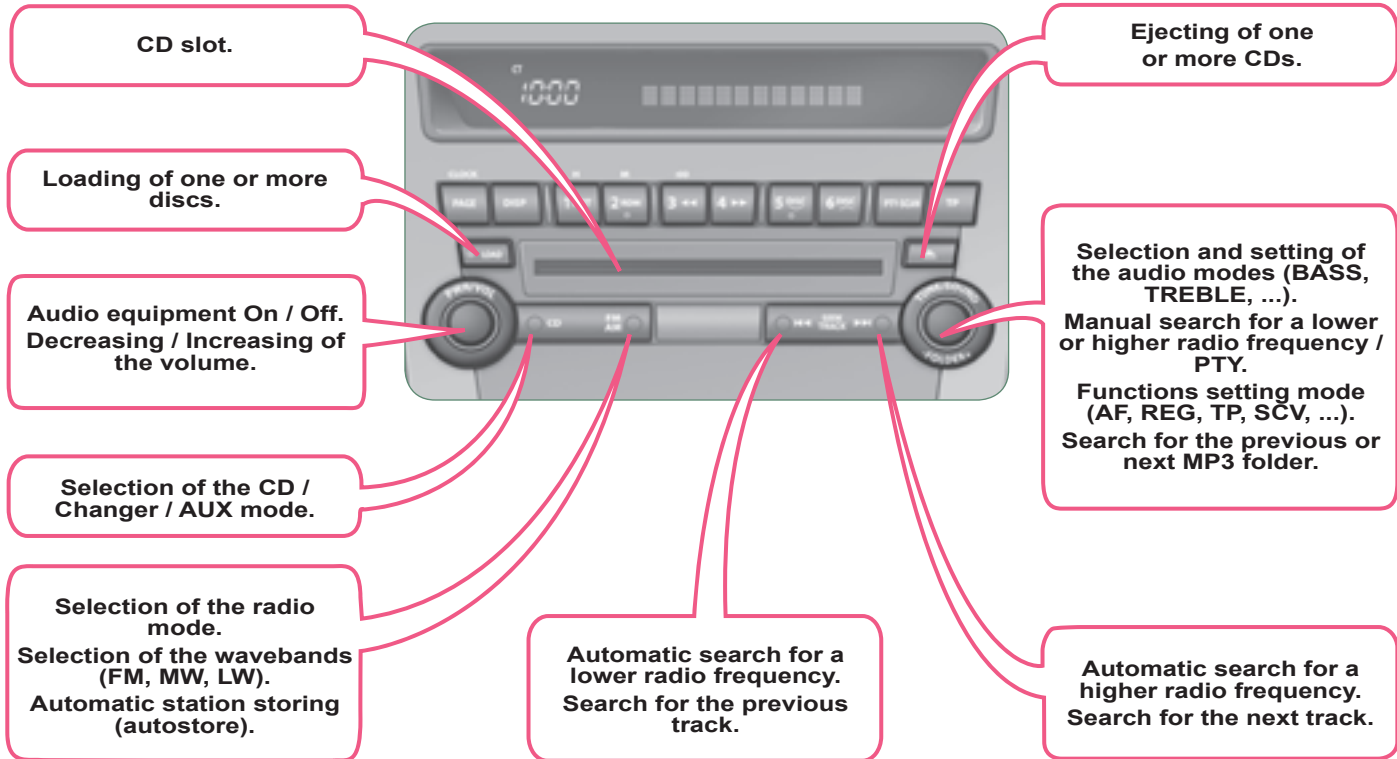

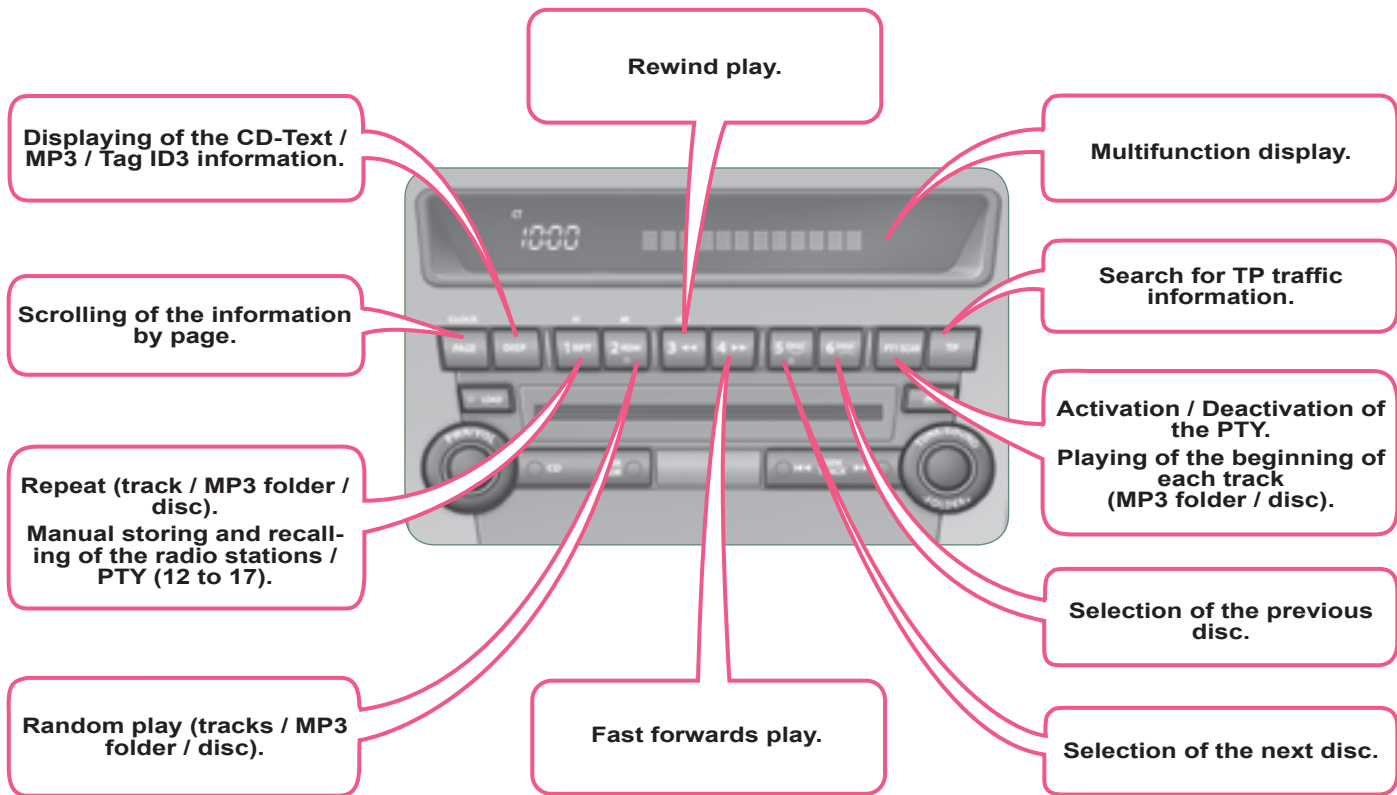

GENERAL FUNCTIONS

Switching on



Press the “PWR” button.
The last source selected before switching off resumes operation.

The audio equipment functions can be used when the ignition switch is in the “ON or “ACC” position.

Switching off

Press the “PWR” button again.

Adjusting the volume



Turn the “VOL” dial respectively to the left to decrease the volume or to the right to increase it.

Setting the audio modes



Press the “SOUND” button several times; the audio modes change in the following order:

SUB PUNCH / TYPE / FIELD / BASS / MID / TREBLE / FADER / BALANCE / OFF.

Quick access mode

To access the personalised sound functions quickly, press and hold this button, then turn it to reach the personalised sound setting of your choice.

Release the button to store the setting.

“Hold” mode

If you press this button for more than 2 seconds in the audio setting mode, the system switches to “Hold” mode. The audio mode selected will be retained until you press this button again for more than 2 seconds.

The audio setting mode is deactivated when the radio is operated or a CD is played or after approximately 10 seconds without any action.

Selecting the musical ambience “TYPE”



Turn the “SOUND” dial; the musical ambiances change in the following order:

CLASSIC / JAZZ / POP / ROCK / HIP-HOP.

Once the ambience has been selected, press the “SOUND” button to confirm.

“CLASSIC”: optimises the acoustics to obtain perfect equalisation of the sound for classical music.

“JAZZ”: optimises the acoustics to obtain an ambient sound with specific modulations in the bass, mid tone and treble for jazz.

“POP”: optimises the acoustics to obtain clear vocals and modulation of the bass and treble for pop music.

“ROCK”: optimises the acoustics to obtain a sound in harmony with the rhythm which places the emphasis on the mid tone for rock music.

“HIP-HOP”: optimises the acoustics to obtain a powerful sound and accentuation of the bass for hip-hop music.

If the “TYPE” is changed, the sound cuts out briefly.

Selecting the surround effect “FIELD”



Turn the “SOUND” dial; the surround effects change in the following order:

NORMAL / STAGE / LIVE / HALL.

Once the surround effect has been selected, press the “SOUND” button to confirm.

“NORMAL”: produces a sound in which the voices are at the front and the instruments surround the listener.

“STAGE”: produces a sound in which the voices are immediately facing the listener, as on a stage.

“LIVE”: produces a sound similar to that of a live show, in which the sound reaches the listener from all directions.

“HALL”: produces a sound similar to that of a concert hall with deflection of the sound.

Setting the bass “BASS”



Turn the “SOUND” dial to set the required bass value.

Setting the mid tone “MID”

Turn the “SOUND” dial to set the required mid tone value.

Setting the treble “TREBLE”

Turn the “SOUND” dial to set the required treble value.

Setting the front/rear sound distribution “FADER”

Turn the “SOUND” dial to set the balance of the volume of the front and rear speakers.

Setting the right/left sound distribution “BALANCE”

Turn the “SOUND” dial to set the balance of the volume of the right and left speakers.

Setting the volume of the bass box “SUB PUNCH”

Turn the “SOUND” dial to set the volume of the bass box.

Only vehicles fitted with the “Premium Sound” system can offer the “SUB PUNCH” setting.

If the “SUB PUNCH” is changed, the sound cuts out briefly.

Automatic volume adjustment “SCV”

This permits automatic adjustment of the “VOLUME”, “BASS”, “MID” and “TREBLE” parameters in relation to the vehicle speed.



Press the “SOUND” button for more than two seconds to gain access to the functions setting mode.

Then, press this same button several times; the

functions setting mode changes in the following order:

AF / CT / REG / TP-S / PTY (languages) / SCV / PHONE / OFF.

Turn the “SOUND” dial respectively to the left to deactivate the function or to the right to activate it.

XI

If the “FIELD” is changed, the sound cuts out briefly.

If the value “0” is set, an audible signal will be heard.

RADIO

Selecting radio mode



Press the “PWR” button or the “AM/FM” button to switch on the radio.

Selecting the waveband



Press the “AM/FM” button several times in succession to select the waveband; it changes in the following order: FM1 / FM2 / FM3 / MW / LW / FM1...

Automatic station search



Press the “SEEK ◀◀” or “SEEK ▶▶” button to search the lower frequencies or the higher frequencies respectively.

The search begins automatically and stops at the first station found.

Manual station search



Turn the “TUNE” dial respectively to the left to search the lower frequencies or to the right to search the higher frequencies.

Manual station storing

You can store up to six stations on each waveband.

Storing a new station replaces the previous station.

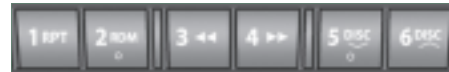

Press one of the six buttons “1” to “6” until an audible signal is heard.

The sound cuts out then becomes audible again when the station has been stored.

The number of the button and the associated radio frequency appear on the display.

To recall the pre-set memory setting, press the button and release it within two seconds.

Automatic station storing

Stations can only be stored automatically on wavebands FM3, MW and LW.

Storing new stations replaces the previous stations.

This storing can be activated automatically irrespective of the waveband selected.



Press the “AM/FM” button for more than two seconds.

The six stations offering the best reception are stored and classified from the weakest to the strongest on the six corresponding buttons.

Recalling stored stations

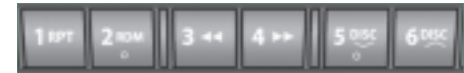

Press one of the six buttons “1” to “6”. The station corresponding to the waveband selected appears on the display.

Disconnecting the battery terminals clears the stored radio stations.

“RDS”

The “Radio Data System” (RDS) function on the FM waveband permits:

- access to the displaying of information, such as the name of the station, ...
- tuning to the same station while travelling through different regions,
- temporary tuning to traffic information announcements.

Most FM stations use the RDS. These stations transmit non-audible data in addition to their programmes.

The data transmitted in this way allows you access to various functions, mainly displaying of the name of the station, automatic station following or temporary tuning to traffic information announcements.

The RDS allows you to continue listening to the same station by means of the alternative frequency following. However, in certain conditions, this RDS frequency following cannot be provided throughout the country. Radio stations do not cover the whole country, which explains the loss of reception of the station during a journey.



The “AF”, “REG” and “TP” functions can be deactivated or activated via the “TUNE” button functions setting mode.

Alternative frequencies “AF”

Your radio automatically checks and selects the best frequency for the radio station to which it is tuned (if the station broadcasts on several transmitters or frequencies).

The frequency of a radio station covers approximately 30 miles (50 km). The change from one frequency to another explains the temporary loss of reception during a journey.

If the station to which you are listening does not have several frequencies in the region in which you are currently located, you can deactivate the alternative frequency following.

Regional following mode “REG”

Some stations are organised in a network.

In different regions, they broadcast different or shared programmes depending on the time of day.

You can follow:

- a regional station only,
- the entire network, with the possibility that you will be listening to a different programme.

On long distance journeys, when the stored station becomes weak, the radio searches first for another frequency for the same station (AF). Then, if this fails, it searches for a frequency broadcasting the regional programme (REG). If this also fails, the radio returns to the stored station.

Traffic information “TP”

The “Traffic Program” (TP) function permits automatic and temporary switching to an FM station broadcasting traffic information.

The radio station or the source that you are listening to at this point is paused.

Once the traffic information has ended, the system switches back to the radio station or the source that you were listening to initially.



Press the “TP” button.

“TP” appears on the display. If the station is compatible, “RDS” also appears.

If the radio detects traffic information, “TRAF INF” appears on the display, followed by the frequency of the broadcasting station, then its name.

The volume is different from that of the previous source.

Following the broadcasting of the traffic information, the volume returns to that of the source prior to the interruption.

When “TP” appears on the display, the radio stops solely at RDS stations broadcasting traffic information.

Emergency broadcasts “ALERT”

An emergency broadcast automatically and temporarily interrupts the FM station or the source that you are listening to.

The message “ALERT” appears on the display and the volume is different from that of the previous source.

Following the emergency broadcast, the message disappears and the volume returns to that of the source prior to the interruption.

Themed type of programme “PTY”

Some stations offer the option of listening to a themed type of programme as a priority, selected from the list available below:

NEWS, AFFAIRS, INFO, SPORT, EDUCATE, DRAMA, CULTURE, SCIENCE, VARIED, POP M, ROCK M, EASY M, LIGHT M, CLASSICS, OTHER M, WEATHER, FINANCE, CHILDREN, SOCIAL, RELIGION, PHONE IN, TRAVEL, LEISURE, JAZZ, COUNTRY, NATION M, OLDIES, FOLK M, DOCUMENT.

Search for a “PTY” broadcast



Press the “PTY” button. Turn the “TUNE” dial to select the type of programme required.

Two seconds later, the radio searches for a broadcast which corresponds to your selection; the type of PTY selected flashes on the display.

Once the station has been found, its name appears on the display.

You can press the “SEEK ◀◀” or “SEEK ▶▶” buttons to find another station.

If no station is found corresponding to your selected type of programme, “NONE” appears on the display for five seconds and the radio returns to the previous station.

Storing a “PTY” programme

You can store up to six PTY programmes.

Each new programme stored replaces the previous one.



Turn the “TUNE” dial to set the PTY programme to be stored.

Press one of the six buttons “1” to “6” for more than two seconds.



The sound cuts out then becomes audible again when the programme has been stored.

The number of the button and the associated PTY programme appear on the display.

To recall the pre-set memory setting, press the button and release it within two seconds.

Changing the display language of the “PTY” programme



Press the “TUNE” button for more than two seconds to access the functions setting mode.

Then, press this button several times in succession; the functions setting mode changes in the following order:

AF / CT / REG / TP-S / PTY (languages) / SCV / PHONE / OFF.

Turn the “TUNE” dial to the left or to the right to select the language (ENGLISH, FRANCAIS, DEUTSCH, SVENSK, ESPAGNOL, ITALIANO).

Functions setting mode

This permits activation or deactivation of the functions below.



Press the "TUNE" button for more than two seconds to access the functions setting mode.

Then, press this button several times in succession; the functions setting mode changes in the following order:

AF / CT / REG / TO-S / PTY (languages) / SCV / PHONE / OFF.

Turn the "TUNE" dial respectively to the left to deactivate the function ("OFF") or to the right to activate it ("ON").

The "PHONE" is not operational at present.

CD PLAYER

Selecting CD mode

After inserting a disc, printed face upwards, the player starts automatically.



If the player already contains a disc, press the "CD" button.

"CD", the track number and the playing time appear on the display.

Insert circular compact discs only.
8 cm compact discs must be inserted in the centre of the player slot.

Ejecting a disc



Press this button to remove the disc from the player. The system automatically switches to radio mode.

Once ejected, if the compact disc is not removed within fifteen seconds, it is reloaded into the player.

Audio CDs

Fast search



Press and hold button "◀◀" or "▶▶" to carry out a rewind or fast forwards search respectively.

Play begins when the button is released.

Selecting a track

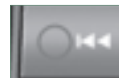

Press button "◀◀" or "▶▶" to select the previous or next track respectively.

Repeating a track

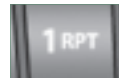

Press the "RPT" button to repeat the playing of the current track. "RPT" appears on the display.

To exit this mode, press this button again.

Random playing of a disc

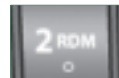

Press the "RDM" button to start random playing of the tracks on the disc. "RDM" appears on the display.

To exit this mode, press this button again.

Functions setting mode

This permits activation or deactivation of the functions below.



Press the "TUNE" button for more than two seconds to access the functions setting mode.

Then, press this button several times in succession; the functions setting mode changes in the following order:

AF / CT / REG / TO-S / PTY (languages) / SCV / PHONE / OFF.

Turn the "TUNE" dial respectively to the left to deactivate the function ("OFF") or to the right to activate it ("ON").

The "PHONE" is not operational at present.

CD PLAYER

Selecting CD mode

After inserting a disc, printed face upwards, the player starts automatically.



If the player already contains a disc, press the "CD" button.

"CD", the track number and the playing time appear on the display.

Insert circular compact discs only.
8 cm compact discs must be inserted in the centre of the player slot.

Ejecting a disc



Press this button to remove the disc from the player. The system automatically switches to radio mode.

Once ejected, if the compact disc is not removed within fifteen seconds, it is reloaded into the player.

Audio CDs

Fast search



Press and hold button "◀◀" or "▶▶" to carry out a rewind or fast forwards search respectively.

Play begins when the button is released.

Selecting a track

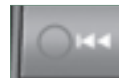

Press button "◀" or "▶" to select the previous or next track respectively.

Repeating a track

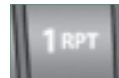

Press the "RPT" button to repeat the playing of the current track. "RPT" appears on the display.

To exit this mode, press this button again.

Random playing of a disc

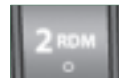

Press the "RDM" button to start random playing of the tracks on the disc. "RDM" appears on the display.

To exit this mode, press this button again.

The functions setting mode is deactivated after approximately 10 seconds without any action.

Playing the beginning of each track



Press the "SCAN" button to start the playing of the first ten seconds of each track on the disc. "SCAN" appears on the display and the corresponding track number flashes.

To exit this mode, press this button again.

On CD-R/RWs, the quality of the playing sound depends on the encoding software, the burning device and the burning speed used.

CD-TEXT DISPLAY

The CD player and the CD changer are compatible with the displaying of CD-Text information.

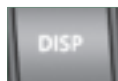

Press the "DISP" button several times in succession; the CD-Text information appears in the following order:

DISC NAME / TRACK NAME / NORMAL DISPLAY MODE.



If the information exceeds 12 characters, press the "PAGE" button to see the rest.

In the absence of CD-Text information to be displayed, "NOTITLE" appears on the display.

MP3 / TAG ID3 CD

The CD player and the CD changer are compatible with the playing of MP3 files.

These must be recorded in ISO9660 Level 1 / Level 2, Joliet or Romeo format on CD ROMs, CD-Rs or CD-RWs. The CDs can contain a maximum of 255 files and 100 folders on 16 levels.

The Tag ID3 version 1 can be displayed while playing MP3 files.

In the case of compact discs containing both CD-DA and MP3 files, play automatically begins with the CD-DA files.

To switch play between the two types of file, press the "CD" button for more than two seconds until an audible signal is heard.

While using these compact discs, the "Repeat", "Random play" and "Playing of the beginning of the tracks" functions are only applied to files of the same format.

Selecting an MP3 folder



Turn the "FOLDER" dial respectively to the right to select a folder in ascending order or to the left to select a folder in descending order.

Repeating the tracks in a folder

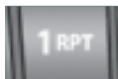

Press the “RPT” button for more than two seconds to repeat the playing of the tracks contained in the current folder. “D-RPT” appears on the display.

To exit this mode, press this button again.

Random playing of a folder

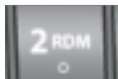

Press the “RDM” button to start random playing of the tracks in the current folder. “RDM” appears on the display.

To exit this mode, press this button again.

Random playing of a disc

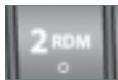

Press the “RDM” button for more than two seconds to start random playing of the tracks in all of the folders. “D-RDM” appears on the display.

To exit this mode, press this button again.

Playing the beginning of each track



Press the “SCAN” button to start playing the first ten seconds of each track in all of the folders. “SCAN” appears on the display and the corresponding track number flashes.

To exit this mode, press this button again.

MP3 / Tag ID3 display

When play begins, “READING” appears on the display then disappears to make way for the folder number, the track number, the playing time and “MP3”.

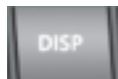

Press the “DISP” button several times in succession; the MP3 information appears in the following order:

FOLDER NAME / TRACK NAME / NORMAL DISPLAY MODE.

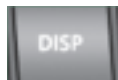

Press the “DISP” button for more than two seconds to activate the Tag ID3 information. “TAG” appears on the display.

Press the “DISP” button several times in succession; the Tag ID3 information appears in the following order:

ALBUM NAME / TRACK NAME / ARTIST NAME / NORMAL DISPLAY MODE.

To deactivate this information, press the “DISP” button again for more than two seconds.



If the information exceeds 12 characters, press the “PAGE” button to see the rest.

In the absence of MP3 or Tag ID3 information to be displayed, “NOTITLE” appears on the display.

On CD-R/RWs, the quality of the playing sound depends on the encoding software, the burning device and the burning speed used.

Depending on the flow chart of the MP3 folders and files on the disc, play may not begin immediately.

CD CHANGER

See also “CD-Text display” and “MP3 / Tag ID3 CD”.

Selecting changer mode

After inserting at least one disc, printed face upwards, the changer starts automatically.



If the changer already contains a disc, press the “CD” button.

“CD”, the disc and track numbers and the playing time appear on the display.

Loading a disc

The CD changer can hold up to 6 CDs. Press the “LOAD” button briefly. “WAIT” appears on the display.

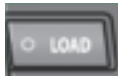

When the changer is ready, the indicator light on the “LOAD” button comes on and “LOAD DISC N° (1-6)” appears on the display.

If several slots are empty, select one using one of the “DISC” buttons.

Insert circular compact discs only.
8 cm compact discs cannot be played by the changer.

Loading all of the discs



Press the “LOAD” button for more than two seconds.

The changer selects an empty slot number from the lowest to the highest and switches to waiting for loading mode.

“LOAD DISC N° (1-6)” appears on the display; insert the disc in the corresponding slot.

The changer automatically selects the next empty slot number and returns to waiting for loading mode.

Repeat these steps until loading is complete. Play begins with the last disc inserted.

Ejecting a disc



Press this button briefly to remove the current disc from the changer.

Ejecting all of the discs



Press this button for more than two seconds. The current disc is ejected.

Once this disc has been removed, the next disc is ejected automatically in its turn.

Repeat these steps until unloading is complete.

Once ejected, if the compact disc is not removed within fifteen seconds it is re-loaded into the changer.

Selecting a disc



Press one of the “DISC” buttons several times in succession until you reach the disc required. The symbol of the disc selected appears on the display.

Audio CD

Fast search

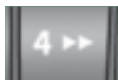

Press and hold button “◀◀” or “▶▶” to carry out a rewind or fast forwards search respectively.

Play begins when the button is released.

Selecting a track



Press button “◀◀” or “▶▶” to select the previous track or next track respectively.

Repeating a track

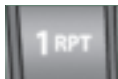

Press the “RPT” button to repeat the playing of the current track. “RPT” appears on the display.

To exit this mode, press this button again.

Repeating a disc

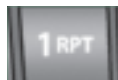

Press the “RPT” button for more than two seconds to repeat the playing of the tracks of the current disc. “D-RPT” appears on the display.

To exit this mode, press this button again.

Random playing of a disc



Press the “RDM” button to start random playing of the tracks on the disc. “RDM” appears on the display.

To exit this mode, press this button again.

Random playing on all of the discs

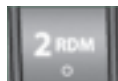

Press the “RDM” button for more than two seconds to start random playing of the tracks on all of the discs. “D-RDM” appears on the display.

To exit this mode, press this button again.

Playing of the beginning of each track

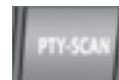

Press the “SCAN” button to start the playing of the first ten seconds of each track on the disc. “SCAN” appears on the display and the corresponding track number flashes.

To exit this mode, press this button again.

On CD-R/RWs, the quality of the playing sound depends on the encoding software, the burning device and the burning speed used.

ERROR MESSAGES

If an error message appears on the display, refer to the table below to find out what it means and the solution to be applied in order to rectify it.

TEXT	DESCRIPTION	SOLUTION
NO DISC	No disc present. Disc not compatible.	Insert a disc.
ERROR 01	Disc inserted incorrectly. Disc with condensation.	Insert the disc with the printed face upwards. Clean the dampness off the disc.
ERROR 02	Disc dirty, scratched or distorted. Excessive vehicle vibration.	Clean or replace the disc. Try again when the vibration has stopped.
ERROR 03	Error on insertion or ejection. Playing head misaligned.	Eject the disc and insert it again. If it is not ejected, have the audio equipment checked.
ERROR HOT	Triggering of the internal protection against high temperatures.	Wait approximately 30 minutes to allow the audio equipment to cool.
ERROR	Communication error between the audio equipment and the external system. External system supply error.	Consult a CITROËN dealer.

AUXILIARY SOCKETS



- A. Left-hand audio input (RCA white)**
- B. Right-hand audio input (RCA red)**
- C. Video input (RCA yellow)**

Connect an external audio system to sockets **A** or **B** to use the vehicle's speakers.

Connect the rear seat display (option) to the additional socket **C** (refer to the user manual supplied with the rear seat display).



For safety reasons, the video is not displayed while driving, however the audio can be played.

To display the picture and watch a DVD, park the vehicle in a safe place.

XI



Audio-CD system

Selecting the AUX source



Press the "CD" button for more than two seconds. "AUX REAR" appears on the display.

The connection to the external audio system is activated.

To deactivate this connection and change source, press the "AM/FM" or "CD" button.



Audio-telematics system

Selecting the AUX source



After pressing "AUX", the connection to the external audio and/or video system is activated.

Selecting the rear display source



After pressing "Rear Display", the connection to the rear audio and/or video system is activated.

To deactivate the connection and change source, press another button on the display (FM, CD, ...).

YOUR AUDIO-TELEMATICS SYSTEM

GPS aerial



This consists of the following components:

- a tilting 7" LCD colour touch screen,
- a GPS aerial located in your fascia,
- a radio aerial located at the rear, on the roof of the vehicle,
- 4 to 6 speakers (according to version),
- controls around the screen and at the steering wheel plus touch buttons on the screen according to the display,
- a voice synthesiser (male or female) giving the directions during navigation,

It allows you to:

- be guided to the destination of your choice (European map on 30 Gb hard disc) taking traffic conditions into account,
- listen to the radio,
- listen to audio CDs (CDDA, CD-Text, CD-R/RW) or CDs with MP3 and WMA files,
- copy audio CDs to a music server, up to 2,500 songs (coded in MP3/WMA) on 10 Gb available on the hard disc,
- play DVDs (playing of video if the vehicle is stationary),
- make hands-free telephone calls.

For maintenance of the display, we recommend the use of a non-abrasive soft cloth (spectacles cloth) without any additional products.

DESCRIPTION OF THE CONTROLS

AUDIO: selection of the Audio-video (FM, CD, music server, ..) or Navigation (map) display.

VOL: adjustment of the audio-video volume.

POWER: audio system on/off (only).

Activation/deactivation of the mute.

Next or previous selection for:

- a radio station,
- an audio track (CD),
- a chapter (DVD).

Setting of the audio volume.

Changing of the audio-video source (FM, CD, music server, ...).



SCALE: changing of the scale of the map.

ENTR: confirms the choice of the item selected on the screen.

For certain operations, confirmation is given by contact with the touch screen.

Scrolling of the map displayed or selection of an item.



OPEN: tilts the display and permits access to the CD/DVD. A second press closes the display.



Move a finger over the screen to operate the system.

Use the buttons offered on the screen.



For safety reasons, it is imperative that the driver carries out operations which require prolonged attention with the vehicle stationary.

DESCRIPTION OF THE CONTROLS - MENUS



MODE: **Audio-video** menu for:

- the radio,
- the audio, MP3 or WMA CD,
- the music server,
- the DVD.

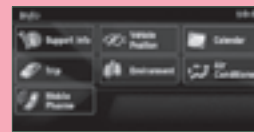

INFO: **Information** menu for the consultation or setting of certain parameters of your vehicle.



SET: **Settings** menu for:

- switching off the display,
- selecting the sound setting,
- selecting the picture quality,
- selecting the language, the time zone or the units,
- selecting the size of the DVD picture,
- selecting the guidance voice, the display colour ranges or the displaying of the audio-video icon,
- setting certain equipment available in your vehicle.



MENU: **Navigation-guidance** menu for selecting:

- a destination,
- a point of interest (POI),
- an advanced search by POI,
- one of the 20 previous destinations,
- an address stored in the address book,
- the return home,
- certain navigation settings,
- a route demonstration.



NAVI: displaying of the current location on the **map**.

NAVIGATION-GUIDANCE

GPS

What is the navigation system and the GPS?

The satellite navigation system guides the driver to the destination that he has set in accordance with a chosen route.

Initially, it searches for the destination required by the user, then it calculates the route and finally it provides the visual and audible guidance instructions.



The GPS (Global Positioning System) consists of several satellites distributed around the earth. They continuously transmit digital signals

which travel at the speed of light, on 2 different frequencies.

At any given time, the system receives its position in relation to the satellites detected and the time of transmission of the signal.

This enables the telematic unit to deduce its position and therefore that of the vehicle.

A repositioning process using the map database stored on the hard disc permits repositioning of the vehicle's position on the road network in order to improve the accuracy of the locating function.

What precautions should be observed in order to use the system under good conditions?

Do not place anything on or near the GPS aerial.

Do not use any digital communication equipment (personal computers, etc.) near the GPS aerial.

Do not affix any reflective films or films containing carbon to the window.

The system's measurements may be inaccurate if the vehicle is:

- in a tunnel or underground car park,
- underneath a two-level motorway,
- in an area with several very high buildings,
- surrounded by closely planted trees.

Depending on the vehicle's situation and the reception of the GPS information, the displayed information may disappear from the display temporarily.

What is a point of interest (POI)?



A point of interest (POI) is represented by an icon on the map, it represents an airport, a station, a town hall, ...



Up to 40 different icons may be displayed (refer to the section "Points of interest icon").

They are classified in 5 groups and identified by one colour for each group:

- Shops, finance and businesses (Green),
- Vehicles and travel (Dark blue),
- Restaurants (Orange),
- Public places and emergency services (Brown),
- Entertainment and attractions (Blue).

Information displayed on the map during navigation



Single map display.



Two-map display.

- A. Manoeuvre icon: indicates whether the driver should turn left or right at the next junction indicated by the guidance and the distance to this junction.
- B. Guidance route: indicates the route to the destination.
- C. Vehicle marker: indicates the position of the vehicle while driving.
- D. TMC icon: displays traffic information such as traffic jams, road works, etc. When the user passes over the icon, detailed TMC information can be consulted.
- E. Orientation mark: indicates the orientation of the map displayed.
- F. Map scale: indicates the scale of the map displayed.
- G. Name of the street: indicates the name of the current street.
- H. Direction frame: displays the number of the next road or the name of the next street which the driver should turn into.
- I. Destination/intermediate destination icon: indicates the direction of the destination or intermediate destination.

- J. Destination/intermediate destination information: indicates the distance and the time remaining until the destination or intermediate destination is reached.



- K. Pressing provides access to the Route Menu in order to:
 - K1 - change the route in favour of another making a detour through a specified region,
 - K2 - change the position of the destination, add an intermediate destination and change the route calculation conditions,
 - K3 - display a route by various methods,
 - K4 - delete a route created,
 - K5 - search for points of interest (POI) around the current location.

Searching for a destination using an address or points of interest (POI)

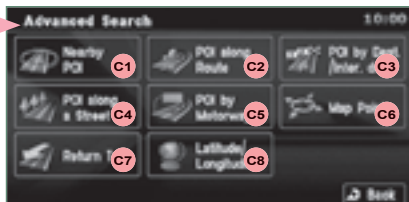
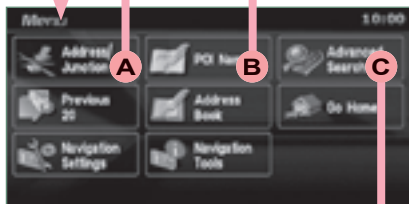

A - Select a location using the address or street name of the destination. Select:

- A1 - the country,
- A2 - the city,
- A3 - the street,
- A4 - the house number,
- A5 - the name of a junction,
- A6 - to select the search using either a number or a junction.

B - Select a location using the name of a point of interest (POI). Select:

- B1 - the country,
- B2 - the city,
- B3 - the name of a stored POI,
- B4 - a POI category (airport, bowling alley, bus station, car park, service station, hotel, cinema, ...),
- B5 - a detailed POI list.

C - Select a location using an advanced search based on a POI:

- C1 - around the current location,
- C2 - on the current route,
- C3 - in the vicinity of the destination,
- C4 - on a chosen street,
- C5 - along a motorway or in the vicinity of the exit,
- C6 - by scrolling the map,
- C7 - taking the point of departure of the current route,
- C8 - specifying the latitude/longitude coordinates.



Searching using previous destinations, a stored address or a return home

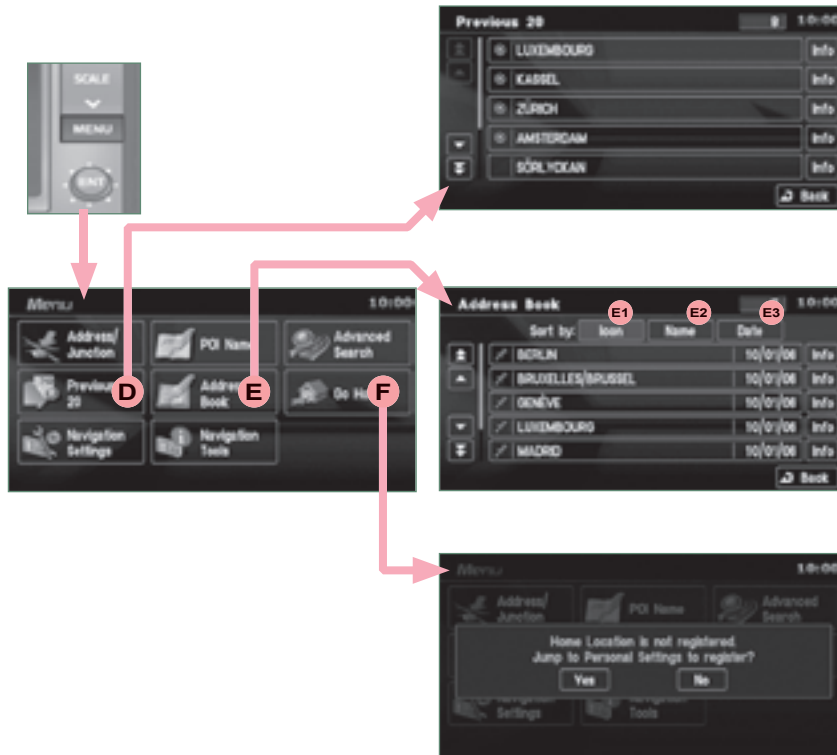

D - Select a location using one of the 20 previous destinations.

E - Select a location using an address stored in the address book. Sort by:

- E1** - Icon,
- E2** - Name,
- E3** - Date.

F - Select a return home directly. Press YES to store your home address (the first time).

Navigation settings and information

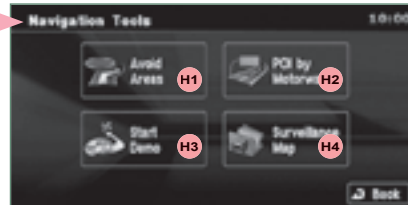

- G** - Select the settings of functions linked with the navigation to:
 - G1** - set the screen display parameters such as:
 - display 1 or 2 maps,
 - display or do not display the POIs on the map, display selected icons,
 - change the colours of the map,
 - display or do not display the name of the current street.
 - display or do not display the address of the current street.
 - G2** - set route conditions,
 - G3** - set the route guidance mode and the displaying of the results of the route search.
 - G4** - save, change or delete a location in the address book,
 - G5** - display and select the traffic information such as traffic jams or road works.
-
- H** - Select basic information relating to the navigation as well as a pre-set route demonstration to:
 - H1** - choose to divert your route to avoid certain areas,
 - H2** - select a location using an advanced search based on a POI along a motorway or in the vicinity of the motorway exit,
 - H3** - start/stop the demonstration,
 - H4** - recall a stored map screen.

Selecting points of interest (POI) icons displayed on the map



You can select up to 40 types of point of interest icon which are displayed on your map screen.

Press the MENU button then [Navigation/Settings].



Press [Screen] then [Select] on the POI line.

Press [] which is displayed.













Press each POI required.







At each contact with a POI, the displaying of [✓] changes (✓ = the POI will be displayed on the screen).

General		Public places and emergency services (Brown)	
	Town centre		Town Hall
	Locality		Community centre
Shops, finance and businesses (Green)			Convention / exhibition centre
	Major companies		Hospital
	Shopping centre		University / college
Vehicles and travel (Dark blue)		Entertainment and attractions (Blue)	
	CITROËN		Theme park
	Airport		Bowling alley
	Bus stop		Casino
	Vehicle hire		Cinema
	Suburban station / station		Golf course
	Ferry terminal		Historical monument
	Hotel		Skating rink
	Park and ride		Marina
	Car park (press +)		Museum
	Service station		Flying club
	Rest area		Leisure area
	Toll booth		Ski station
	Tourist information		Sports centre
	Railway station		Theatre / opera
Restaurant (Orange)			Tourist attraction
	Night life / night club		Vineyard / wine and spirit store
	Restaurant		

Entering an address and activating guidance (1/2)



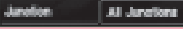

Press	Explanations	Result
	<p>Press the MENU button.</p>	
	<p>Press [Address/Junction].</p>	
	<p>Press [Country] and enter the name of the country using the touch keypad. When a character of the name of the country is entered, if 5 countries or fewer are recognised, you can select a country from a list which is displayed or press [List].</p>	
 <div data-bbox="343 593 416 620" style="background-color: #333; color: white; padding: 2px 5px; display: inline-block;">Last 5</div> <p data-bbox="435 586 1182 630">You can select one of the 5 most recently selected countries by pressing [Last 5] on the "Country" line.</p>		
	<p>Press [City] then [Keyword] and enter the name of the city using the touch keypad. When a character of the name of the city is entered, if 5 cities or fewer are recognised, you can select a city from a list which is displayed or press [List].</p>	
 <div data-bbox="343 854 416 880" style="background-color: #333; color: white; padding: 2px 5px; display: inline-block;">Post Code</div> <p data-bbox="435 841 903 886">You can select a city using the post code. Press [Post Code] and enter the number.</p>		
 <div data-bbox="343 982 416 1008" style="background-color: #333; color: white; padding: 2px 5px; display: inline-block;">Last 5</div> <p data-bbox="435 969 1177 1013">You can select one of the 5 most recently selected cities by pressing [Last 5] on the "City" line.</p>		

Entering an address and activating guidance (2/2)

Press	Explanations	Result
	<p>Press [Street] and enter the name of a street using the touch keypad. When a character of the name of the street is entered, if 5 streets or fewer are recognised, you can select a street from a list which is displayed or press [List].</p>	
	<p>Press [House #] and enter the number of the house using the touch keypad.</p>	
<div style="display: flex; align-items: center;">  <div style="display: flex; align-items: center;">  </div> </div>	<p>You can enter the name of a junction instead of the number of the street. Press [Junction] and select the name from a list which is displayed.</p>	

This is what you obtain once all of the information has been entered:



	<p>If you agree with the information press [Set], otherwise press one of the buttons to correct.</p>	
	<p>Press [Start] to start the navigation.</p>	

AUDIO-VIDEO

Radio, RDS, AF, REG, TP, PTY

What is the RDS?

RDS The Radio Data System (RDS) function on the FM waveband permits:

- tuning to the same station while travelling through different regions (if the transmitters of this station cover the area through which you are travelling),
- temporary tuning to traffic information announcements,
- access to the displaying of the name of the station, etc ...

Most FM stations use the RDS.

These stations transmit non-audible data in addition to their programmes.

The data transmitted in this way allows you access to various functions, mainly displaying of the name of the station, temporary tuning to traffic information announcements or automatic station following.

The RDS allows you to continue listening to the same station by means of the frequency following. However, in certain conditions, this RDS frequency following cannot be provided throughout the country. Radio stations do not cover the whole country, which explains the loss of reception of the station during a journey.

RDS station following

AF Your radio automatically checks and selects the best frequency for the radio station to which it is tuned (if the station broadcasts on several transmitters or frequencies).

The frequency of a radio station covers approximately 30 miles (50 km). The change from one frequency to another explains the loss of reception during a journey.

If the station to which you are listening does not have several frequencies in the region in which you are currently located, you can deactivate the automatic frequency following.

Regional following mode

REG Some stations are organised in a network.

In different regions, they broadcast different or shared programmes depending on the time of day.

You can follow:

- a regional station only,
- the entire network, with the possibility that you will be listening to a different programme.

Traffic information function

TP The Traffic Program (TP) function permits automatic and temporary switching to an FM station broadcasting traffic information.

The radio station or the source that you are listening to at this point is paused.

Once the traffic information has ended, the system switches back to the radio station or the source that you were listening to initially.

Programme types

PTY Some stations offer the option of listening to a themed type of programme as a priority, selected from the list available below:

NEWS, AFFAIRS, INFOS, SPORT, EDUCATE, DRAMA, CULTURE, SCIENCE, VARIED, POP M, ROCK M, EASY M, LIGHT M, CLASSICS, OTHER M, WEATHER, FINANCE, CHILDREN, SOCIAL, RELIGION, PHONE IN, TRAVEL, LEISURE, JAZZ, COUNTRY, NATION M, OLDIES, FOLK M, DOCUMENT.



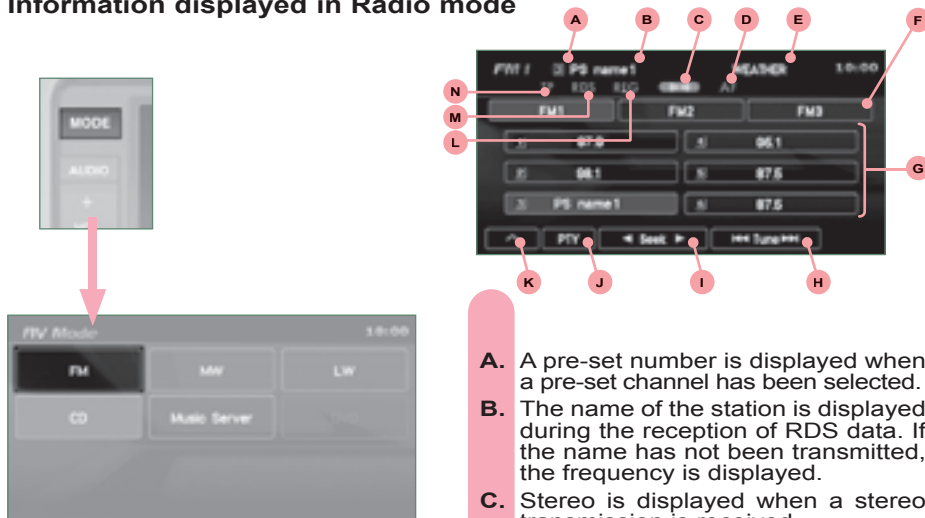













Information displayed in Radio mode











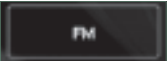

- A.** A pre-set number is displayed when a pre-set channel has been selected.
- B.** The name of the station is displayed during the reception of RDS data. If the name has not been transmitted, the frequency is displayed.
- C.** Stereo is displayed when a stereo transmission is received.
- D.** AF is displayed when the AF control function is activated.
- E.** PTY (programme type) is displayed if the RDS data received is displayed. TRAFINF is displayed, during an interruption, for traffic information. ALARM is displayed, during an interruption, for urgent information.
- F.** Displaying of 6 stored stations.

- G.** To receive the stored station. Press and hold to store a station.
- H.** To change the frequency step by step. Press and hold for scrolling of the frequency.
- I.** To search for currently broadcasting stations which can be received in the current location, until a station is found.
- J.** To display the programme types pre-setting screen, e.g.: sport, rock, classical, news, ... Press PTY again to exit.
- K.** Press this button to display the secondary menu.
- L.** REG is displayed during the reception of regional frequencies data.
- M.** RDS is displayed during the reception of RDS data.
- N.** TP is displayed when the traffic information is in standby mode.

Radio, selecting an FM station and storing

Press	Explanations	Result
	Press the MODE button.	
	Press FM. By default the display shows the FM1 stations.	
	Press [◀ Tune] to decrease the frequency or [Tune ▶] to increase the frequency. The frequency is changed in steps of 0.1 MHz. Continue to press to tune to a station automatically.	
<div style="background-color: #f08080; padding: 10px;"> <div style="display: flex; align-items: center; margin-bottom: 10px;">  <div style="display: flex; align-items: center;">  <div> <p>You can select [◀ Seek] or [Seek ▶] to start a continuous search until the stations which can be received in the current location are detected.</p> </div> </div> </div> <div style="display: flex; align-items: center;">  <div style="display: flex; align-items: center; margin-left: 10px;">  <div> <p>You can also start a search by type of programme by pressing [PTY].</p> </div> </div> </div> </div>		
 107.8  PS name 1	Once the frequency has been selected, a maintained press on the station (e.g. 3) will store it. The name of the station (e.g. PS name 1) is displayed if it is available.	
 	You can start automatic storing on FM3 for 6 stations, which can be received in the current location, by pressing [^] then [Auto-Store].	

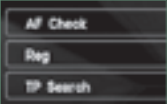
Radio, RDS settings

Press	Explanations	Result
	Press the MODE button.	
	Press FM. By default the display shows the stations on FM1.	
	Press [^].	
	Press [RDS Settings]. Press [On] or [Off] to activate or deactivate the functions:	
	<ul style="list-style-type: none"> - AF: automatic search for the best frequency, - REG: switch to the regional frequencies, - TP: automatic selection of stations broadcasting traffic information. 	

General notes on CDs

Playing an audio CD



When the audio CD is inserted in the player, playing of the tracks is automatic and they can be recorded onto the hard disc.

Simultaneous access to the music recognition service “Gracenote CDDB” on the hard disc permits displaying of the title information.

Recording onto the music server

The tracks of audio CDs (not MP3/WMA) can be recorded onto the hard disc at approximately 4x speed (e.g.: 60 minutes converted to 15 minutes) and stored on the music server.

The sounds recorded may be altered by the noise present and the quality of the sound may differ from the original.

The tracks recorded on the music server cannot be reproduced on another medium (CD-R/RW, HDD, etc ...).

Previously recorded tracks cannot be recorded again from the same CD.

Switching off the engine or removing the CD during recording will result in the tracks being faulty.

The operation of the navigation system may slow down during recording.

The recording speed may be slower than 4x due to the processing load on the equipment or the condition of the audio CD.

If jumps or other errors occur, return to the beginning of the track and start the recording again.

Even if there is no gap between the tracks on the CD, a brief silence between tracks is stored on the hard disc.

What is the Gracenote CDDB?



The title information for the track currently being played can be obtained from the “Gracenote CDDB” database stored on the hard disc.

The Gracenote company uses this standard to identify the music and the associated information such as:

- the title of the album,
- the name of the artist,
- the title of the tracks,
- the genre, ...

For further details, consult the site: www.gracenote.com.

The Gracenote CDDB database incorporated in this equipment cannot guarantee the content of the data 100%. You can update this database using a DVD sold separately.

Copyright

Your Audio equipment may allow you to listen to music which is usually protected by copyright in accordance with current national and international standards. Please consult these standards and comply with them.

Information displayed in CD mode and recording a CD



The CD button is only active if the player contains a CD.



Press Open to return the display to the vertical position.

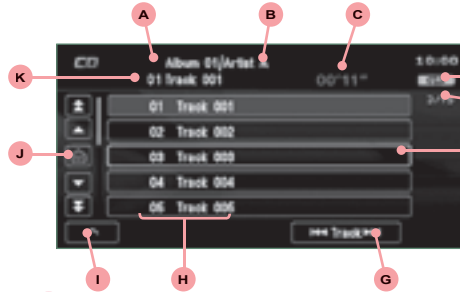





- A. The name of the album is displayed for the track currently being played.
- B. The name of the artist is displayed for the album currently being played.
- C. The playing time of the track currently being played is displayed.
- D. The playing mode currently selected is displayed.
- E. Position of the cursor and total number of tracks on the album.
- F. Displays the item currently selected.
- G. To scroll up or down through the tracks. Press and hold for rewind or fast forwards playing of a track.

- H. Displays the number and the name of the track. While driving, they are not available and cannot be selected.
- I. To display the secondary menu.
- J. Move the cursor onto the track currently being played.
- K. The number and the name of the track currently being played are displayed.



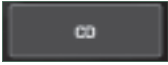

- L. During recording, this symbol is displayed in red and it switches off when all recording operations are complete. The number indicates the percentage of the total number of tracks on the CD already recorded onto the hard disc. 00% when only one track has been recorded.
- M. The tracks which have not been recorded are displayed in blue. No symbol is displayed for tracks which have been recorded.







Playing a CD

Press	Explanations	Result
 	Press the MODE button then CD, if the player already contains a CD.	
 	Otherwise, insert a CD in the player, play begins automatically.	

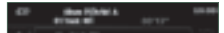











Selecting a track

	Press [Track] to select the previous track or return to the beginning of the track currently being played. Press and hold for rewind play.	
	Press [Track] to select the next track. Press and hold for fast forwards play.	

Changing the play mode

	Press [^] to access the secondary menu.	
	Press [Repeat] to play the track in a loop (repetition). Press [^] then [Repeat] to stop.	
	Press [Scan] to play the beginning of each track for approximately 9 seconds (scan). Press [^] then [Scan] to stop or press the current track (during the 9 seconds) and play begins.	
	Press [Random] to play the tracks in random order. Press [^] then [Random] to stop.	













Recording a CD onto the music server (1/3)

Press	Explanations	Result
Automatic recording of all of the tracks		
	All of the tracks are recorded automatically when a CD is inserted. This automatic recording is programmed by default on leaving the factory.	
	If you have changed the recording mode (manual or first track), while a CD is being played press [^] to access to secondary menu.	
	Press [REC. Setting].	
	Press [Auto REC.] and confirm by pressing [Back].	
	Next, eject the CD currently being played then insert a CD and the recording of all of the tracks begins.	
	If you wish to record the CD which is currently being played, press [^] to access the secondary menu and press [REC. Start].	



If another track (already recorded) is selected during recording, the recording continues and the new track selected is played.
 If another track (not recorded) is selected, the recording which is in progress stops and the recording of the new track selected begins. This track is played during recording.

















Recording a CD onto the music server (2/3)

Press	Explanations	Result
 	<p>Manual recording of individual tracks</p> <p>You can record the tracks manually, one by one. After inserting a CD and while it is being played, press [^] to access the secondary menu.</p>	
	<p>Press [REC. Setting].</p>	
 	<p>Press [Manual REC.] and confirm by pressing [Back].</p>	
 	<p>Once the manual programming has been carried out, select the track to be recorded then press [^].</p>	
	<p>Press [REC. Start], the recording of the track selected begins.</p>	



If another track is selected during recording, the recording stops and the new track selected is played.

Recording a CD onto the music server (3/3)

Press	Explanations	Result
 	<p>Automatic recording of the first track</p> <p>You can programme the automatic recording of the first track when a CD is inserted.</p> <p>After inserting a CD and while it is being played, press [^] to access the secondary menu.</p>	
  	<p>Press [REC. Setting] then [Single REC.] and confirm by pressing [Back].</p>	
	<p>Next, eject the CD which is currently being played then insert a CD and the recording of the first track begins.</p>	
 	<p>If you wish to record the first track of the CD which is currently being played, press [^] to access the secondary menu and press [REC. Start].</p>	
<p> If another track is selected during recording, the recording stops and the track selected is played.</p>		
	<p>Stopping automatic or manual recording</p> <p>During the recording of a CD or of a track on a CD, press [^] to access the secondary menu.</p>	
	<p>Press [REC. Stop], the recording stops.</p>	

General notes on the Music Server

What is the music server?

The tracks on audio CDs (not MP3 or WMA) can be recorded onto the hard disc at approximately 4x speed and stored on the music server.

Refer to the “Recording a CD” section.

The music server then allows you to manage groups and lists of tracks.

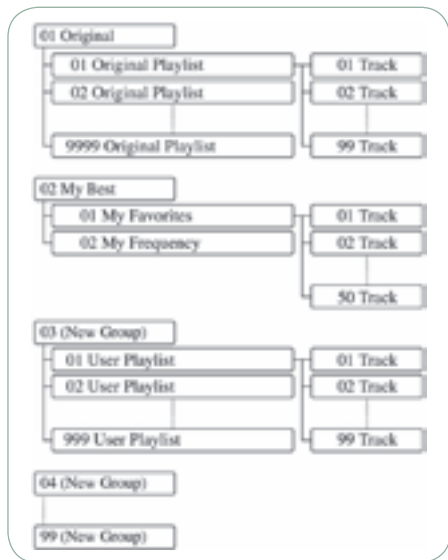

“Original” group, number 01:

01 Original This is the location of the original playlist created automatically (not manual) when a track of an audio CD is recorded.

It is not possible to change its name or delete it.

You can record up to 9999 playlists in this group.

“Original Playlist” lists:

01 Original Playlist
02 Original Playlist These are original playlists created automatically (not manual) when an audio CD is recorded.

The lists and the artists can be renamed or deleted. The genres can also be set.

“My Favorites” list:

01 My Favorites This is the location for storing your favourite tracks.

They can be deleted from the list and the order in which they are played can be changed.

“My Best” group, number 02:

02 My Best This is the location of the playlists, etc ... created automatically from the information read on the music server.

It is not possible to change its name or delete it.

The groups “My Favorites” and “My Frequency” are stored here.

“My Frequency” list:

02 My Frequency This is the location of the playlists used most frequently from the **original list**.

It is not possible to add tracks or change their order.

“New Group” group for the user, numbers 03 to 99:

03 (New Group) This is the location of the user’s playlists.

You can record up to 9999 playlists in this group.

The group can be created, renamed or deleted.

“User Playlist” list:

01 User Playlist This is the location of a playlist of tracks selected by the user from the **original list**.

If you delete a track from the original list, it will be deleted from the user list.

The list and the artist can be renamed or deleted.

It is possible to add tracks or change their order.

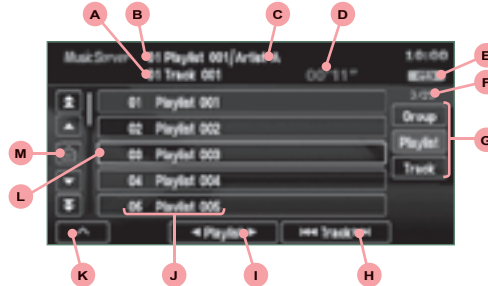
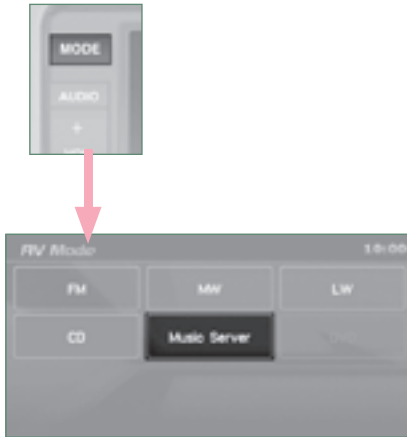

Information displayed in Music Server mode



- A. The number and the name of the track currently being played are displayed.
- B. The number and the name of the playlist currently being played are displayed.
- C. The name of the artist is displayed for the playlist currently being played.
- D. The playing time of the track currently being played is displayed.
- E. The playing mode currently selected is displayed.
- F. Group lists: position of the cursor and total number of groups. Playlists: position of the cursor and total number of playlists. Track lists: position of the cursor and total number of tracks.

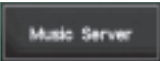

- G. To display the list of groups, the playlist and the list of tracks.
- H. To scroll up or down through the tracks. Press and hold for rewind or fast forwards playing of a track.
- I. To scroll up or down through the playlists.
- J. Group lists: number and name of the group. Playlists: number and name of the playlist. Track lists: number and name of the track.
- K. To display the secondary menu.
- L. Displays the item currently selected.
- M. Move the cursor onto the track currently being played.



Playing a track or a playlist on the Music Server

Press	Explanations	Result
 	Press the MODE button then Music Server.	



The playlists are played in a loop.
 The server can play a track while recording another track from a CD. You must wait until recording is complete before playing the recorded track.









Selecting a track		
	Press [⏮ Track] to select the previous track or return to the beginning of the track currently being played. Press and hold for rewind play.	
	Press [Track ⏭] to select the next track. Press and hold for fast forwards play.	

Selecting a playlist		
	Press [◀ Playlist] to select the previous playlist.	
	Press [Playlist ▶] to select the next playlist.	



Press these buttons to switch between groups, playlists and tracks.
 You cannot switch directly from groups to tracks.

Creating a group and a playlist on the Music Server

Press	Explanations	Result
Creating a group		
	Press [^] to access the secondary menu.	
New Group	Press [New Group], enter the name of the group and confirm by pressing [SET]. The group is stored on the server.	
Set		
Creating a playlist		
	Press [^] to access the secondary menu then press [Function Settings].	
Function Settings		
New Playlist	Press [New Playlist].	
03 Group 01	Select the group to which the playlist is to be attached. The group must be created first.	
Playlist 027	Enter the name of the playlist and confirm by pressing [SET]. Then select the search method attached to this new list (either from the list or by conditions). The list is stored on the server.	

General notes on MP3/WMA CDs

Playing an MP3/WMA CD

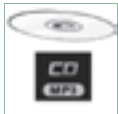

When the MP3/WMA CD is inserted in the player, playing of the tracks is automatic.

The tracks cannot be recorded onto the music server.

You can play up to 8 levels, 255 folders and 400 files maximum.

What is the MP3/WMA file format?

MP3 is the abbreviation of MPEG-1 Audio Layer 3 and MPG is the abbreviation of Motion Pictures Experts Group, a digital video data compression standard used on media such as video CDs.

The MP3 compression reduces the number of bytes in a song by eliminating the long sound waves in the range of frequencies which are imperceptible to the human ear, so producing high quality audio files with a low volume of data.

This compression divides the size of the content of a conventional audio CD by approximately 10, which means that the content of 10 audio CDs can be recorded onto a single CD-R or CD-RW.

WMA is the abbreviation of Windows Media Audio, another audio data compression standard offered by Microsoft.

It can be used to create and save audio files at a compression rate higher than that of the MP3 format.

Windows Media and Microsoft Corporation are trademarks registered in the United States and/or other countries.

Acceptance of the files

Some burned CDs may not be played by your equipment (quality, recording speed ...).

When you burn a CD-R or CD-RW, select the ISO 9660 level 1.2 or Joliet burning standard.

To obtain the best acoustic quality possible, select the lowest burning speed.

The MPEG1 and MPEG2 standards are accepted.

Transmission speeds between 32 and 320 kbits/s and scans between 16 kHz and 48 kHz are accepted.

To display the title information (the name of the artist, the title of the album, etc...), the information contained in the ID3 Tags or the WMA Tags must be included in the MP3/WMA files burned onto the disc.

Copyright

Your Audio equipment may allow you to listen to music which is usually protected by copyright in accordance with current national and international standards. Please consult these standards and comply with them.

Information displayed in MP3/WMA CD mode

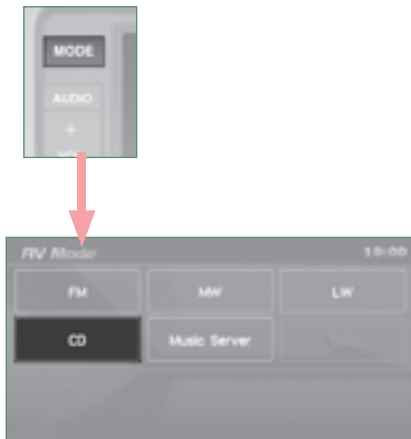

The CD button is only active if the player contains a CD.





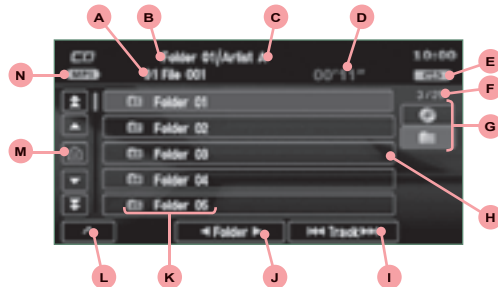







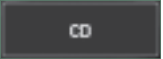

Press Open to return the display to the vertical position.

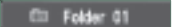









- A. The number and the name of the track currently being played are displayed.
- B. The name of the album/folder is displayed for the track currently being played.
- C. The name of the artist is displayed for the track currently being played.
- D. The playing time of the current track is displayed.
- E. The playing mode currently selected is displayed.
- F. Position of the cursor and total number of folders or tracks on the current level.
- G. To display the list of folders of a higher level.
- H. Displays the item currently selected.

- I. To scroll up or down through the tracks. Press and hold for rewind or fast forwards playing of a track.
- J. To scroll up or down through the folders.
- K. Displays the folder number and the folder name. Plus the lists and numbers of tracks and the name of the file (without extension).
- L. To display the secondary menu.
- M. Move the cursor onto the track currently being played.
- N. Displays the type of medium, MP3 or WMA.

Playing an MP3/WMA CD (1/2)

Press	Explanations	Result
 	Press the MODE button then CD, if the player already contains a CD.	
<div style="background-color: #f8d7da; padding: 10px;">   <p>Otherwise, insert a CD in the player, play begins automatically.</p> </div>		
<h3 style="text-align: center;">Moving around the folders</h3>		
	You can move by one level at a time. Press on the name of a folder and at each press the list of folders of the level below is displayed.	
<div style="background-color: #f8d7da; padding: 10px;">  <div style="display: flex; align-items: center;">  <div style="margin-left: 10px;"> <p>These displays indicate the current level: CD: level 0, folder below: level 1, folder below that, level 2, etc ... Up to 8 levels maximum.</p> </div> </div> </div>		
	Press on the folder above to move up and/or select a level.	
<h3 style="text-align: center;">Selecting a folder</h3>		
	Press [◀ Folder] to select the previous folder. Press [Folder ▶] to select the next folder.	

Playing an MP3/WMA CD (2/2)

Press	Explanations	Result
	<p>Selecting a track</p> <p>Press [⏮ Track] to select the previous track or return to the beginning of the track currently being played. Press and hold for rewind play.</p>	
	<p>Press [Track ⏭] to select the next track. Press and hold for fast forwards play.</p>	
	<p>Changing the playing mode</p> <p>Press [^] to access the secondary menu.</p>	
	<p>Press [Repeat] to play the track selected in a loop (repetition). Press [Repeat] again to play all of the tracks in the selected folder in a loop. Press again to stop.</p>	
	<p>Press [Scan] to play the beginning of each track in each folder for approximately 10 seconds (scanning). Press [Scan] again the play the beginning of each track in the selected folder in a loop. Press again to stop or press on the current track (during the 10 seconds) and play begins.</p>	
	<p>Press [Random] to play all of the tracks in the selected folder in random order. Press [Random] again to play all of the tracks on the CD in random order. Press again to stop.</p>	

Information displayed in DVD mode



The DVD button is only active if the player contains a DVD.



XI

Press Open to return the display to the vertical position.

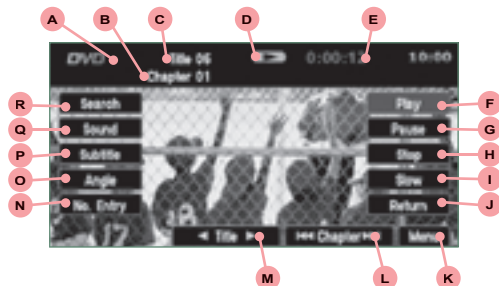

- A. This icon is displayed when the operation requested cannot be carried out.
- B. The number of the chapter currently being played is displayed.
- C. The number of the title currently being played is displayed.
- D. Symbols display the current status of the player.
- E. The playing time is displayed.
- F. To resume normal play when play is paused or during slow-motion play.
- G. To stop play temporarily.
- H. To stop play. Press the screen to access the menu.
- I. For slow-motion play.
- J. To play the previously selected zone on the disc.







- K. To display the DVD title menu.
- L. To scroll up or down through the chapters.
- M. To scroll up or down through the titles.
- N. To enter a title or chapter number.
- O. To change the angle.
- P. To change the language of the subtitles.
- Q. To change the language.
- R. To select a chapter or title or specify a number.



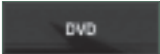

For safety reasons, the video is not displayed while driving, however the audio can be played.

To display the picture and watch a DVD, park the vehicle in a safe place.



Playing a DVD

Press	Explanations	Result
 	<p>Press the MODE button then DVD, if the player already contains a DVD.</p>	
 	<p>Otherwise, insert a DVD in the player, the picture is displayed automatically. Press the screen to access the menus.</p>	
	<p>While driving, the sound band alone is played and no picture is displayed.</p>	

Selecting a chapter

	<p>Press [⏮ Chapter] to select the previous chapter or return to the beginning of the chapter currently being played. Press and hold for rewind play.</p>	
	<p>Press [Chapter ⏭] to select the next chapter. Press and hold for fast forwards play.</p>	

Selecting a title

	<p>Press [◀ Title] to select the previous title.</p>	
	<p>Press [Title ▶] to select the next title.</p>	

SETTINGS

Display, sound, picture



A - Choose to switch off the display. To switch it back on, touch the screen or press any button.

B - Choose the settings of the sound in the vehicle, if an audio source is selected (FM, CD, ...), for:

B1 - the sound distribution or the volume such as the front-rear balance, the bass, the medium, the treble, the volume adjustment in relation to the vehicle speed,

B2 - the type of music (with surround option) such as classic, jazz, pop, rock, hip hop, country, normal, ...

B3 - the sound field (with surround option) such as stage, live, hall, normal, ...

C - Choose the quality of the picture for:

C1 - the colour (when playing DVDs),

C2 - the intensity of the colours (when playing DVDs),

C3 - the brightness,

C4 - the contrast,

C5 - the level of black.

Time and date, language, unit, picture size

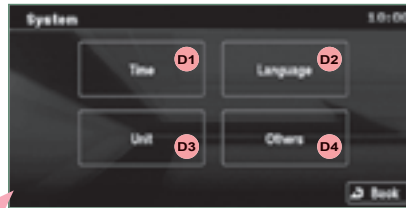

D - Choose the base settings of the system for:

- D1 - setting of the time by the RDS signal, time zone, summer time,
- D2 - the language (English, Français, Deutsch, Nederlands, Portugese, Español, Svenska, Italiano, Dansk),
- D3 - the units for calculation of the distances (km or miles and °C or °F),
- D4 - other settings such as:
 - the voice guidance volume,
 - the type of voice guidance voice (female or male),
 - the volume of the operation beeps (1 to 3 and 0=no beep),
 - the type of inputting keypad (alphabet or PC),
 - the range of menu colours (red or blue),
 - the displaying or not of the audio playing icons on the map screen,
 - the reinitialisation of the vehicle sensor,
 - the interruption or not of the display when the air conditioning is used.

E - Choose the size of the DVD picture for:

- E1 - normal 4/3,
- E2 - extends the picture evenly to the right and to the left in wide screen mode,
- E3 - extends the right and left parts only leaving the centre as it stands in wide screen mode,
- E4 - enlarges the picture in 4/3 format. The top and the bottom are outside the frame.

Equipment, contrast, traffic information (TP)



F - Choose to adjust or set the parameters of certain equipment offered in your vehicle (e.g.: unfolding/folding of the mirrors, raising of the windows on locking, timing and sensitivity of the automatic lighting, direction indicators motorway function, ...):

F1 - to scroll up the list,

F2 - to scroll down the list,

F3 - to reinitialise all of the settings (manufacturer's settings).

Press each setting to select or change the parameters.

G - Choose to adjust the contrast of the display in relation to the exterior light (day, night or automatic).

H - Choose to activate or deactivate the traffic information (TP).

INFORMATION

System version, satellite



- A - Consult the system information:
 - A1 - the software version,
 - A2 - the map data version,
 - A3 - the system information database version.

To update the versions, insert the DVD containing the new data and follow the instructions on the screen.
- B - Consult the GPS information:
 - B1 - the satellite positions diagram with the direction of movement of the vehicle. Plus the position of the satellite signal receivers,
 - B2 - the name of the current location,
 - B3 - the longitude and latitude of the current location,
 - B4 - the position measurement status (2D=3 satellites or fewer, 3D=4 satellites or more),
 - B5 - the number of receiving satellites,
 - B6 - to have north at the top of the map,
 - B7 - to have the direction of the vehicle at the top of the map,
 - B8 - to pivot the map from overhead or change the angle of the map.

Calendar, trip

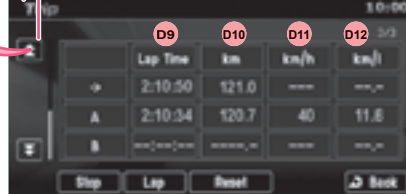
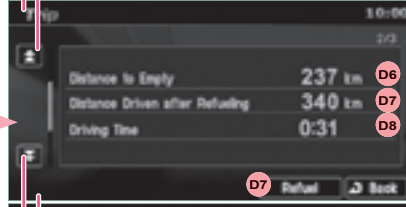

These double arrows permit access to the driving information screen, previous or next.

C

- Make a note on the calendar of special days, birthdays, ...
- Use the arrows to find a date and press directly on the day required to enter the event.

D

- Consult the driving information:
- D1 - the average speed,
- D2 - the average consumption,
- D3 - the current consumption,
- D4 - for speed and consumption graphs in 5 minute intervals,
- D5 - choose an automatic reinitialisation (key at off for more than 4 hours) or manual reinitialisation (press reset),
- D6 - the distance which can still be travelled (in relation to the fuel remaining and the recent average consumption),
- D7 - the distance travelled since the fuel tank was last filled (press refuel to reinitialise),
- D8 - the driving time (duration between the key being turned to on then to off).
 - press start to measure intermediate times with:

D9

- the duration,
- D10 - the distance,
- D11 - the speed,
- D12 - the consumption.

Environment, air conditioning, telephone

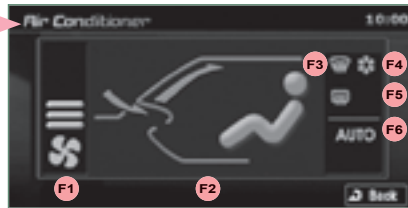

E

- Consult the environment information:
- E1 - the altitude,
- E2 - the atmospheric pressure,
- E3 - the exterior temperature. The ice symbol flashes if there is a risk of ice.

F

- Consult the air conditioning conditions:
- F1 - the fan speed indicator,
- F2 - the air selection indicator,
- F3 - the windscreen demisting indicator light,
- F4 - the air conditioning indicator,
- F5 - the rear screen demisting indicator light,
- F6 - the AUTO mode indicator.

G

- Make and receive telephone calls:
- G1 - enter the telephone number,
- G2 - delete a character,
- G3 - make the call.

Refer to the hands-free telephone section to connect your Bluetooth® mobile telephone.

HANDS-FREE TELEPHONE

General notes

What is the Bluetooth® hands-free telephone with voice recognition?



The system uses wireless communication technology referred to as Bluetooth® which allows you to make hands-free telephone calls in your vehicle via your Bluetooth® compatible mobile telephone.

It has a voice recognition function which allows you to make telephone calls using a microphone, located in the courtesy light, and also by means of easy use of the steering wheel controls or using voice commands. Five languages are available: English (by default), Spanish, French, German and Italian.

Audio system on/off.

Increasing of the audio volume.

Decreasing of the audio volume.



PICK UP
Press to answer an incoming call.
If a second incoming call is received, press this button to place the first call on hold and speak to the second caller.
In this case, a brief press switches between callers.
To establish a three-way conversation, press the SPEAK button to switch to voice recognition mode and say "Incorporate the call".

SPEAK
Pressing activates the voice recognition ("Listening" is displayed).
During voice recognition, a brief press pauses this recognition.
An extended press deactivates the recognition.
A brief press will activate the recognition even if a telephone call is progress.

HANG UP
Press to reject an incoming call.
During a call, pressing ends this call.

Changing the language, programming the voice

Changing the language of the voice commands

By default, the recognition system is in English.



1 - Press the SPEAK button.



2 - Say "Setup".



3 - Say "Language".

4 - The system says "Select a language: English, Spanish, French, German or Italian".



5 - Say the language of your choice in English, example: say "French" for French.

6 - The system then says "French selected. Is this correct?"



7 - Say "Yes" to start the change of language process or say "No" to return to steps 4 to 7.

8 - The system repeats the language chosen and completes the change of language process.

Programming the user's voice

You can use the user's voice programming function to create a voice model for one person per language.

The characteristics of your voice and your pronunciation are recorded in this model for improved voice recognition.

It is essential that the vehicle is parked in a safe place, with the handbrake applied.

Switch off your telephone during the process to avoid any interruption.



1 - Press the SPEAK button.



2 - Say "Word training".

3 - An explanation message is given.



4 - When you are ready to start, press and hold the SPEAK button.

5 - The system says the first of 45 typical phrases.



6 - Repeat each phrase in the table on the next page.

The system records your voice and moves on to the recording of the next command.

Continue the process until all of the phrases have been recorded.

7 - After reading all the voice commands, the system says "The word enrolment is complete" and ends the process.

If you do not start the programming process within approximately 3 minutes after pressing the SPEAK button, the process is cancelled.

If you press the SPEAK button within 5 seconds following the reading of a voice command, the recording of this command is repeated.

Programming controls

1	# 790 (for # = "Hash")	16	55 66 77 88 99	31	Home, Work, Mobile, Pager
2	* 671 (for * = "Star")	17	44 33 22 11 00	32	List of names
3	212 - 4 903	18	Call 293 - 5804	33	No
4	235 - 3 494	19	Call * 350	34	Phone book: Delete
5	315- 5 657	20	Call 1 (234) 567 - 8 901	35	Phone book: New entry
6	456 - 7 930	21	Dial 639 - 1542	36	Previous
7	793 - 5 462	22	Dial # 780	37	Phone book: Clear all
8	794 - 1 826	23	Dial (987) 654 - 3210	38	Redial
9	826 - 3 145	24	1058# 3794# Send	39	Repeat the training
10	962 - 7 305	25	27643# 4321# Send	40	Configure the confirmation requests
11	(531) 742 - 9 860	26	Cancel	41	Configure the language
12	(632) 807 - 4 591	27	Continue	42	Configure the matching options
13	(800) 222 - 5015	28	Emergency number	43	Match a telephone
14	(888) 555 - 1 212	29	Clear all	44	Transfer the call
15	0 123 456 789	30	Help	45	Yes

Matching your Bluetooth® telephone

The system can register up to 7 Bluetooth® compatible mobile telephones.

The telephone which has the highest level of priority is matched automatically.

It is absolutely essential that the vehicle is parked in a safe place with the handbrake applied.



1 - Press the SPEAK button.



2 - Say "Configure".



3 - Say "Matching options".

4 - The system says "Do you wish to match a telephone, delete a telephone or obtain the list of matched telephones?".



5 - Say "Match a telephone".

6 - The systems says "Please say the 4 digits of a matching code".



7 - Say a 4-digit number which will be recorded as the matching code.



8 - The system confirms the validity of the number spoken, answer "Yes". Say "No" to return to step 7.

You can choose any 4-digit number. Remember this matching code as you must enter it in the telephone in one of the following steps of the matching procedure.

9 - The system says "Start the matching procedure on the telephone. Consult the instructions in the telephone manual".



10 - Consult your mobile telephone's user manual and enter the matching code recorded in step 7 in the telephone.

11 - When it detects a Bluetooth® compatible mobile telephone, the system says "Please say the name of the telephone after the bleep".



12 - After the audible signal, allocate a name to the telephone by saying the name of your choice.

13 - The system says "Allocate an order of priority between 1 and 7. One is the highest level of priority".



14 - Say a number between 1 and 7 to establish the level of priority of the mobile telephone.

15 - The system says and confirms the <name of the telephone> and the <number> of its priority.



16 - Answer "Yes" or say "No" to return to step 13.

17 - The systems says "Matching complete" then emits an audible signal and deactivates the voice recognition.

If the system does not detect the Bluetooth® compatible mobile telephone, the matching process stops accompanied by an audible signal.

If you select a level of priority which has already been allocated to another telephone, the system asks you if you wish to replace this level of priority.

Making a telephone call using a number, phone book

A Bluetooth® compatible mobile telephone must be matched with the system.

Using a telephone number



1 - Press the SPEAK button.



2 - Day “Dial”.

3 - The system says “Number please”.



4 - Say the telephone number.



5 - The system asks you to confirm this number, answer “Yes”. Say “No” to return to the previous step.



If your vehicle is fitted with the audio-telematics display, you can use the press buttons to dial a number then make a call.

Recording a name in the system’s phone book

The system has its own phone book, independent of that of the mobile telephone.

It can contain up to 32 names for each language.

Each name in the phone book is associated with 4 locations: HOME, WORK, MOBILE and PAGER.



1 - Press the SPEAK button.



2 - Say “Phone book”.

3 - The system says “Select one of the following items: New Entry, Change, List of names, Delete or Clear all, or say Cancel to return to the main menu”.

To enter a new number:



4 - Say “New entry”.

5 - The system says “Name please”.



6 - Say the name of your choice.

7 - The system says “HOME, WORK, MOBILE OR PAGER”.



8 - Say the location which corresponds to the number that you wish to record.

9 - The system asks you to confirm the location.



10 - Answer “Yes” or say “No” to return to step 7.

11 - If a telephone number has already been recorded for this location, the system says “The current number is <number>, number please”.



12 - If you do not wish to change the telephone number, repeat the original number to retain it, otherwise say the new number.

13 - The system asks you to confirm the number.



14 - Answer “Yes” or say “No” to return to step 11.

Making a telephone call using a name in the phone book, receiving a call

Using a name in the system's phone book

The name must be recorded in the system's phone book.



1 - Press the SPEAK button.



2 - Say "Call".

3 - The system says "Name please".



4 - Say the name of the person that you wish to call.

5 - If several telephone numbers have been recorded for this person, the system says "Do you wish to call <name> {home}, {work}, {mobile} or {pager}?"



6 - Say the location corresponding to the number that you wish to call.

7 - The system requests confirmation of the name.



8 - Answer "Yes" or say "No" to return to step 4.

9 - The system says "Call to <name> at <location>" and makes the call.

Redialling the last number



1 - Press the SPEAK button.



2 - Say "Redial".

Receiving a call

The telephone ring is transmitted on the speaker by the front passenger's seat.

If an audio source (CD, radio, ...) is in operation when the call is received, it is placed on mute and only the incoming call is heard.

When the ignition switch is in the ACC or ON position, the audio system is activated automatically if an incoming call is received, even if it was originally off.



1 - Press the PICK UP button.

At the end of the call, the audio system returns to its previous status.

Voice commands (1/2)



Press this button to start the voice recognition.

Configure	Divert the call	Home, at home
Phone book	Add a location	Work, at work
Dial	Configure the confirmation requests	Mobile, on mobile
Call	Language	Pager, on pager
Redial	New entry	Help
Emergency number	Delete	Continue
Matching options	Change	All
Match a telephone	Call this number	Cancel
Delete a telephone	Change another entry	Mute
List of matched telephones	Try again	Deactivate mute
Select a telephone	Clear all	Yes
Previous	List of names	No

XI

When the system is waiting for a voice command, say “Help” to obtain a list of commands which can be used in the current situation.

Voice commands (2/2)



Press this button to start the voice recognition.

Zero	English	Word training
One	Phone book New entry	PIN
Two	Phone book Change	Repeat training
Three	Phone book Delete	Activate
Four	Phone book Clear All	Deactivate
Five	Phone book List of names	Incorporate the call
Six	Configure the confirmation requests	<digits> Send
Seven	Configure Select a telephone	
Eight	Configure the matching options	
Nine	Delete a name	
Star (*)	Configure the language	
Hash (#)	Configure the PIN	

When the system is waiting for a voice command, say "Help" to obtain a list of commands which can be used in the current situation.