

EXTERIOR

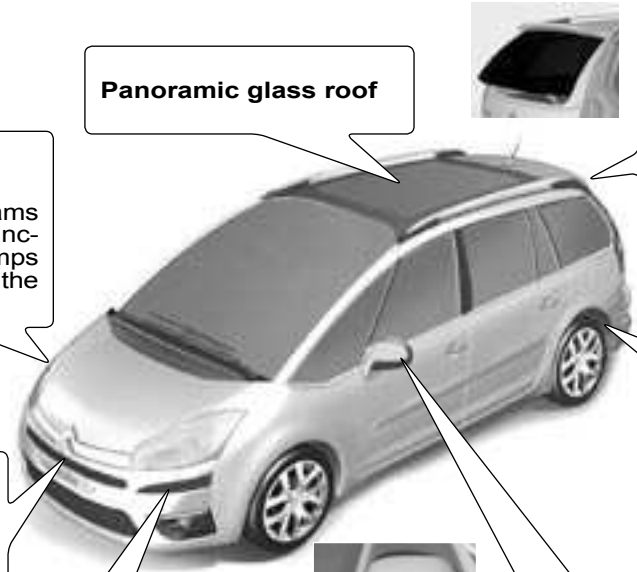

Panoramic glass roof



Opening rear screen

▶▶ 138

Xenon directional headlamps
 Whether on dipped beams or main beams, this function allows your headlamps to follow the direction of the road ahead.

▶▶ 94

Front/rear parking assistance
 Sensors located in the bumpers detect obstacles.

▶▶ 95-96

Pneumatic rear suspension
 The rear pneumatic suspension enhances driving comfort and maintains a constant body height whatever the vehicle load.

▶▶ 145



Parking space sensor
 Measures the size of a space and informs you of the possibility of parking.

▶▶ 76-77

Exterior side lighters
 These light up the zones facing the driver's and passenger's doors.

OPENING

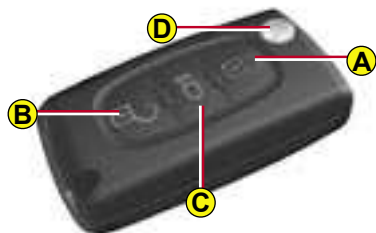

Remote control key

- A. Central locking
- B. Unlocking
- C. Guide-me-home lighting
- D. Key release/storage

▶▶ 22-23

Bonnet opening/closing

To unlock, pull the control located under the dashboard towards you.

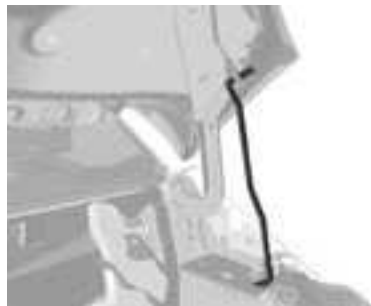

Bonnet stay : detach the stay and pivot it upwards to insert it into the notch.



To close : move the stay back to its initial position, lower the bonnet and then allow it to slam shut.

▶▶ 163



Fuel tank (60 litres)

Press on control **A** located on the control panel to the left of the dashboard. The fuel flap automatically opens up fully.

Insert the nozzle so as to push in the metallic gate valve **B**.

Push the fuel flap to reclose it.

▶▶ 162

After switching off the ignition, control **A** is only active for a few minutes.

If necessary, switch on the ignition again to reactivate it.

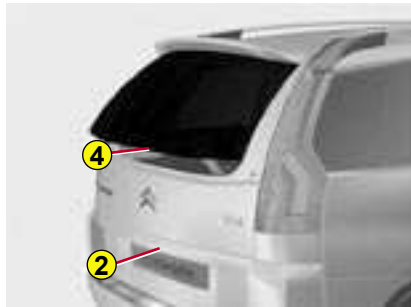

Opening rear screen

This opening gives you enhanced access to the boot, even if you are parked close to a wall or to another vehicle.

Opening

- Press on control 2. The handhold 4 is in line with the rear wiper.

Closing

- Lower the rear screen.

▶▶ 138

OPENING

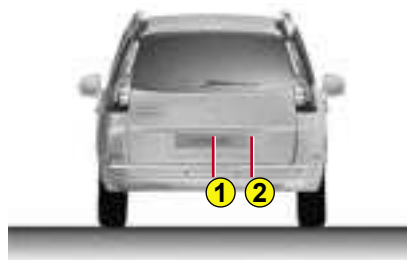

Opening the tailgate

- Press on control 1.

Note : You cannot open the tailgate if the rear screen is already open.

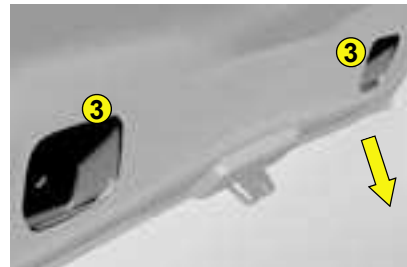

Closing the tailgate

- Lower the tailgate, using one of the handholds 3, located on the inside of the tailgate trim.
- Past the balancing point, allow the tailgate to close itself (do not assist it or slow it down).



MODUBOX (22 kg maximum) C4 Picasso

The Modubox is composed of a shopping trolley and a flexible bag which can be used independently of each other depending on your needs.

▶▶ 140

BOOT

C4 Picasso

Luggage cover in two sections

▶▶ 139

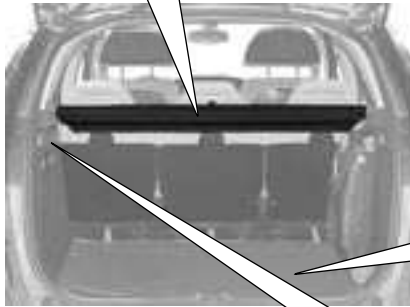

Grand C4 Picasso

Luggage cover blind

▶▶ 142-143

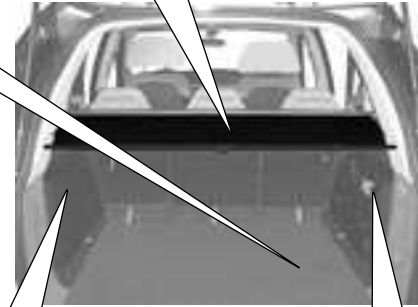

Access to spare wheel

▶▶ 187



Portable lamp

▶▶ 132



Pneumatic rear suspension
Allows the height of the rear of the vehicle to be adjusted

▶▶ 145-146



Portable lamp



PUNCTURE REPAIR KIT

The puncture repair kit is located either in the compartment under the left hand second-row passenger or in the boot well (according to equipment).

This puncture repair kit is a complete system including a compressor and a setting product.

▶▶ 185

INTERIOR

Third-row seats – Grand C4 Picasso

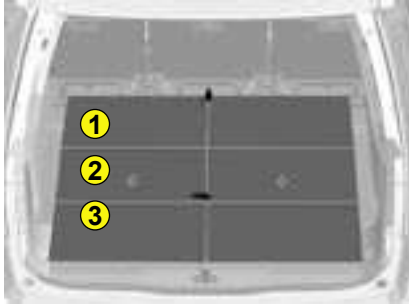

To return the seats to the upright position

Fold the concertina plates (1 2 3) arranged on each of the third-row seats.

Pull on the black belt **F** located on the seat backrest.

▶▶ 119

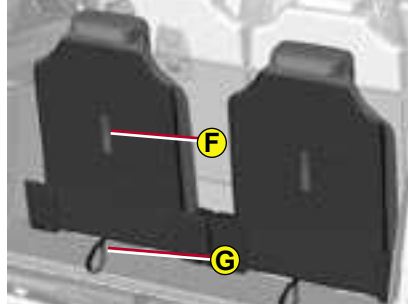

To stow the seats

Put the three sections of the concertina plates (1 2 3) to their vertical position then pull on the red belt **G**.

Before moving the third-row seats, return the rigid plates to the upright position and lock them.

Do not leave objects either on or underneath the second-row seats when you are folding them.

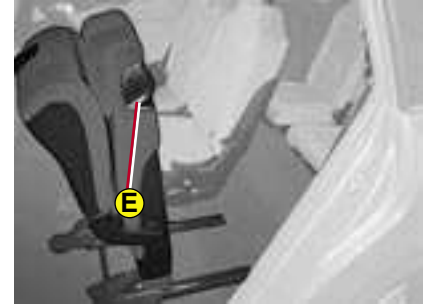

Access to third-row seats

Pull on control **E** located at the top of the second-row seats backrest.

▶▶ 118

Third-row seats – Grand C4 Picasso

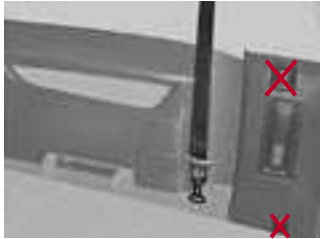

Requirements for third-row passenger seat belts

Take care to attach the third-row passenger seat belts on the rings provided for this purpose. **Do not attach the belts on the anchoring points marked with a red cross (see illustration above).**



Stowing the tongue of the third-row seat belt

INTERIOR

Second-row seats

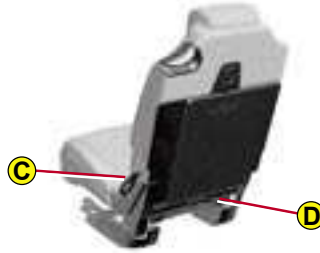

TO FOLD THE SEATS

From outside

- Pull upwards on control **C** as indicated by the red arrow, to unlock the seat.

From the boot - whilst loading, for example (Grand C4 Picasso)

Having firstly folded the third-row seats.

- Pull on control **D** to unlock the required seat.

TO RETURN THE SEATS TO THE UPRIGHT POSITION

Return the rigid plates of the second-row seats to their initial (upright) position and lock them in position (Grand C4 Picasso).

Raise the backrest and push it backwards until it locks in position.

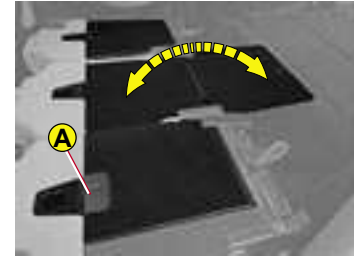

RIGID PLATE (Grand C4 Picasso)

A rigid plate is attached to each second-row seat backrest.

To unlock / lock the rigid plate :

- Slide latch **A** of the plate downwards, to unlock it.
- Return the plate to the upright position, then slide latch **A** upwards to lock it.

Note : Before deploying the rigid plates, check that the second-row seats are slid as far back as possible.

INTERIOR

Second-row seats

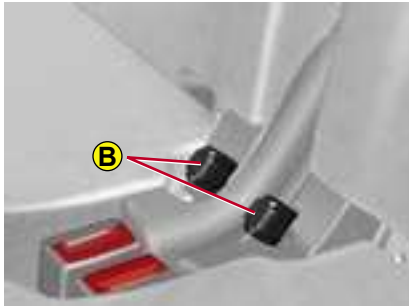

THE « COMFORT » POSITION

The 3 second-row seats are independent of each other and are all the same width. They can all be adjusted to the « comfort » position.

To place the seat(s) in the comfort position

- Pull on control **B**.

The backrest reclines and the seat base pivots slightly.

To return the seat to its original position

- Pull on control **B** and allow the seat to come forward.

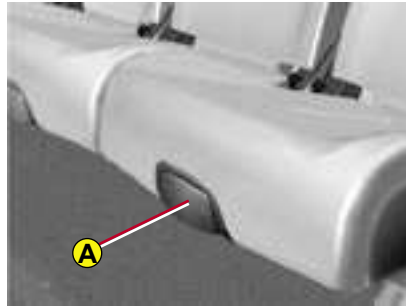

LONGITUDINAL ADJUSTMENT

Lift up control **A**, located at the front of the seat, and adjust the seat into the desired position.

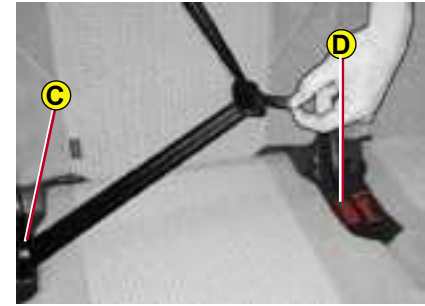

Positioning the central seat belt

- Insert tongue **C** into the buckle on the right, then insert the second tongue **D** into the buckle on the left.

DASHBOARD

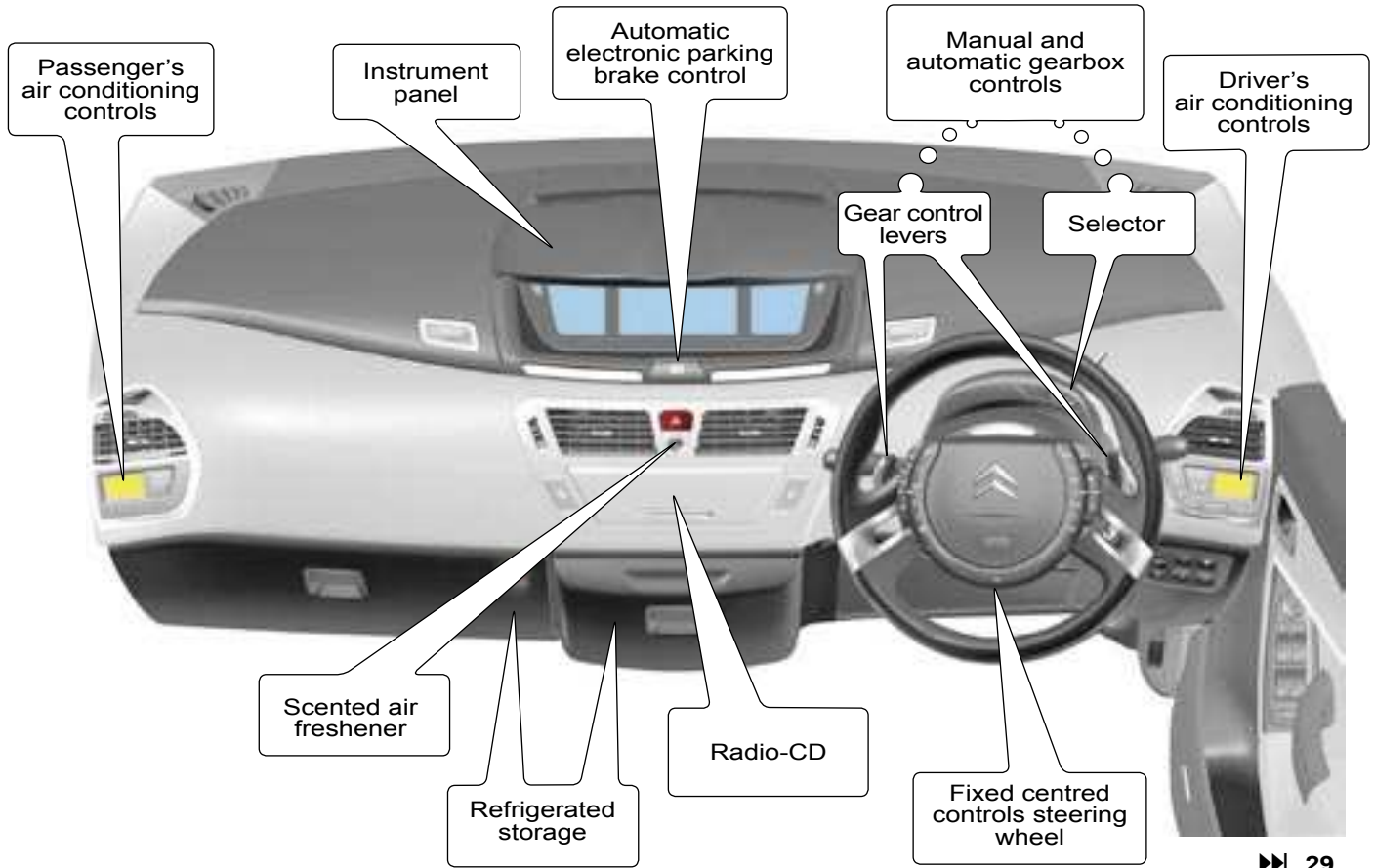

GETTING STARTED

Front seats

Manual adjustments

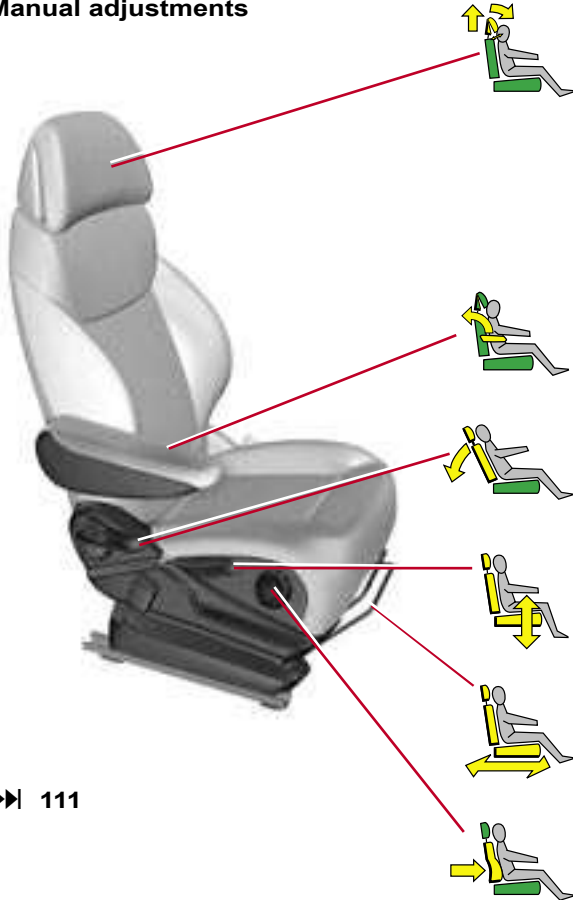

Head restraint

Armrest

Backrest angle

Driver's seat height adjustment

Longitudinal adjustment

Lumbar support

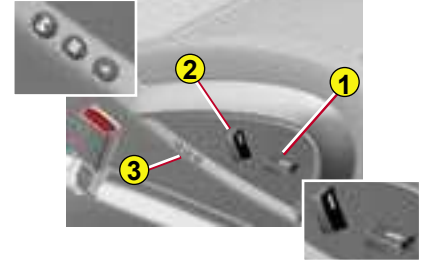

Electric adjustments :

- ❶ Adjustment of seat height and angle, longitudinal adjustment
- ❷ Adjustment of backrest angle and lumbar support
- ❸ Driver : memorisation of driving positions

Note : The seats can also be adjusted on a temporary basis :

- on opening one of the front doors,
- after switching on the ignition.



Heated seat control
(located on the inside of the front seats)

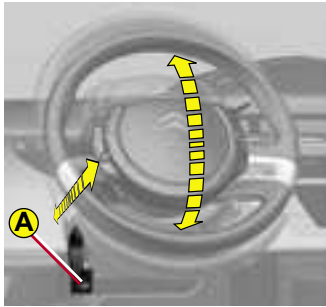

Adjusting the steering wheel

The steering wheel can be adjusted in terms of height and reach.

Unlock the steering wheel by pulling control **A** towards you.

Adjust the position of the steering wheel then lock it pushing the control back fully.

►► 86

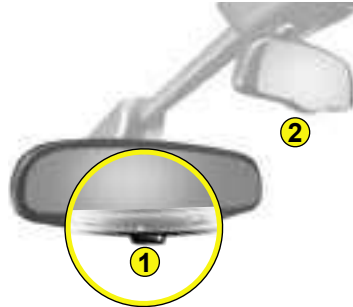

Automatic photochromic interior rear view mirror

This modifies its role automatically and progressively between day use and night use.

It can be deactivated using control **1**.

Child mirror (2)

This allows you to monitor the rear passengers. It can be folded away to eliminate dazzle.

►► 84

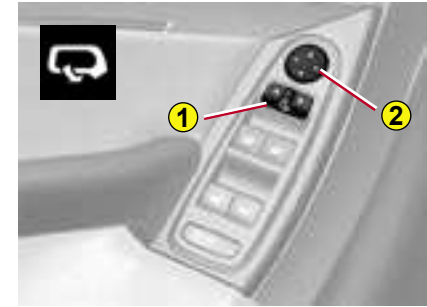

Rear view mirrors adjustment

This operates with the ignition switched on.

From the driver's seat, select the rear view mirror by moving control **1** to the left or right, then adjust the rear view mirror as required in the 4 directions using control **2**.

Demisting-deicing of the rear view mirrors is linked to that of the rear screen.

Rear view mirrors foldback

When the vehicle is parked, the rear view mirrors can be folded back either manually or automatically.

►► 85

GETTING STARTED

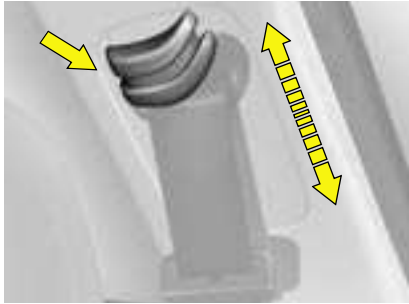

Adjusting the seat belt height

To adjust the seat belt, pinch the control and slide it in the direction required.

▶▶ 86



Electric windows controls

From the driver's seat position, the controls located on the door enable the electric windows to be controlled.

▶▶ 97

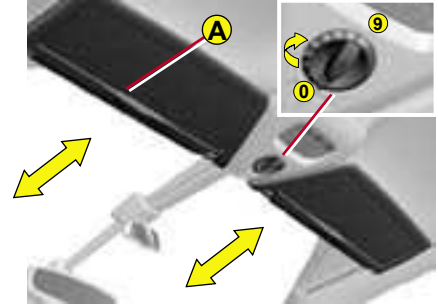

Sliding sun visors

- Slide the blind on the visor to the desired position by pushing the area **A**.

The blinds are extended on the sun visor struts.

- Fold the visor downwards, to protect against being dazzled.

Panoramic glass roof blind

Opening (positions **1** to **9**)

Closing (position **0**)

The blind has an anti-pinch device.

▶▶ 87

DRIVING

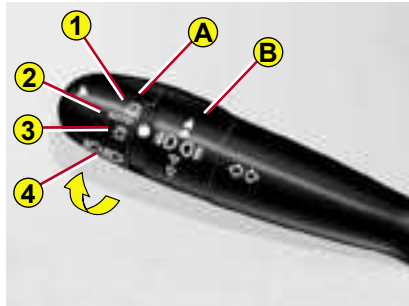

LIGHTING CONTROL

Ring A

- 1 Off
- 2 Automatic lighting
- 3 Sidelamps
- 4 Dipped beams / Main beams

Ring B

- Front foglamps
- Rear foglamps

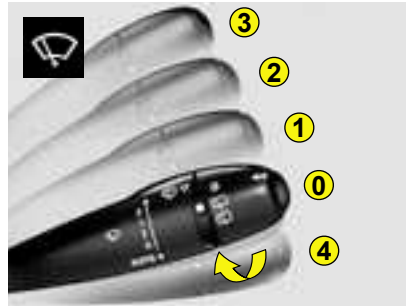

Windscreen wiper

- 3 Rapid wipe.
- 2 Normal wipe.
- 1 Intermittent wipe.
- 0 Off.
- 4 Automatic wipe by pressing downwards, and single wipe.

Note : To deactivate automatic wipe :
- go to position **1**, then return to position **0**.

Rear screen wiper



Stop.



Intermittent.



Timed wash and wipe.

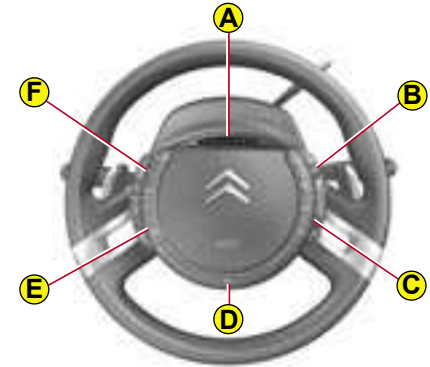

- A Warning lamps for vehicle lamps and direction indicators
- B Audio system controls
- C Multifunction display controls
- D Horn
- E Optional function controls
- F Cruise control and speed limiter

▶▶ 80

▶▶ 82-88

DRIVING

**(6-Speed) electronic gearbox system**

- R** Reverse
- N** Neutral
- A** Automatic mode
- M** Manual mode

Using control levers + and - :

- Gear changing in manual mode
- Temporary manual operation in automatic mode.

To start**(6-Speed) electronic gearbox system**

- Check that you are in neutral (position **N**).
- Press firmly on the brake pedal and turn the ignition key.

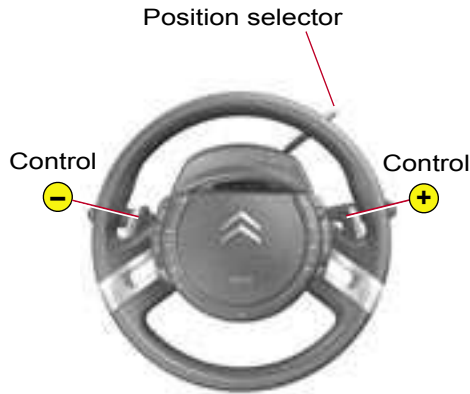
**Automatic gearbox**

- P** Park
- R** Reverse
- N** Neutral
- D** Automatic mode
- M** Sequential mode

Using control levers + and - :

- Gear changing in sequential mode
- Temporary manual operation in automatic mode.

To start**Automatic gearbox**

- Check that you are in position **P** or **N** and turn the ignition key.

Note : To exit position **P**, press on the brake pedal before moving the selector.

DRIVING



Electronic parking brake

This device combines :

- automatic functions :

Automatic application when the engine stops and automatic release on use of the accelerator (automatic operation by default) ;

- manual use :

Permanent manual application / release of parking brake is possible by pulling control **A**.

▶▶ 68-74

Hill start assist

To aid starting on a gradient, your vehicle is equipped with a system which keeps it immobilised for about 2 seconds, the approximate time it takes to move your foot from the brake pedal to the accelerator pedal.

▶▶ 75

**Before leaving the vehicle, check that the electronic parking brake warning lamp P (red) is permanently on.
If you leave the vehicle with the engine running, manually apply the parking brake.
Never leave a child alone inside the vehicle with the ignition on, as they could release the parking brake.**

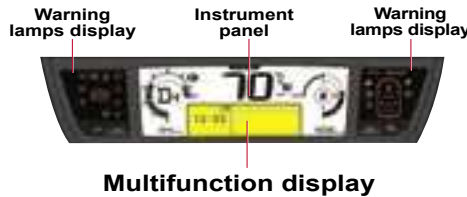

▶▶ 32-33

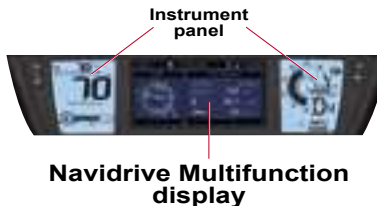

▶▶ 34

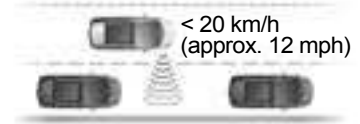

Parking space sensor



You can select the « parking space sensor » function by pressing on button **A**.

Once the space has been measured, the function displays the following messages :

Parking possible

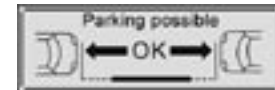

Parking difficult



Parking not advised

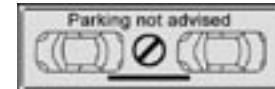

▶▶ 76-77

VENTILATION

Automatic air conditioning

DRIVER'S AND PASSENGER'S CONTROL PANEL

REAR PASSENGERS' CONTROL PANEL

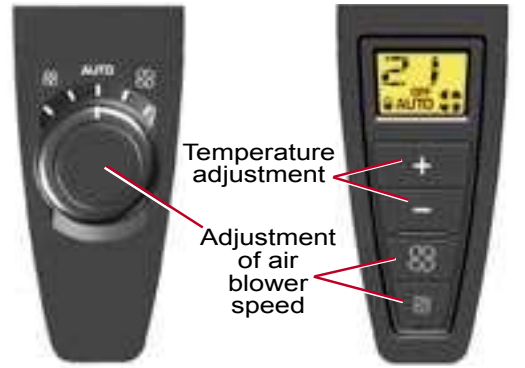
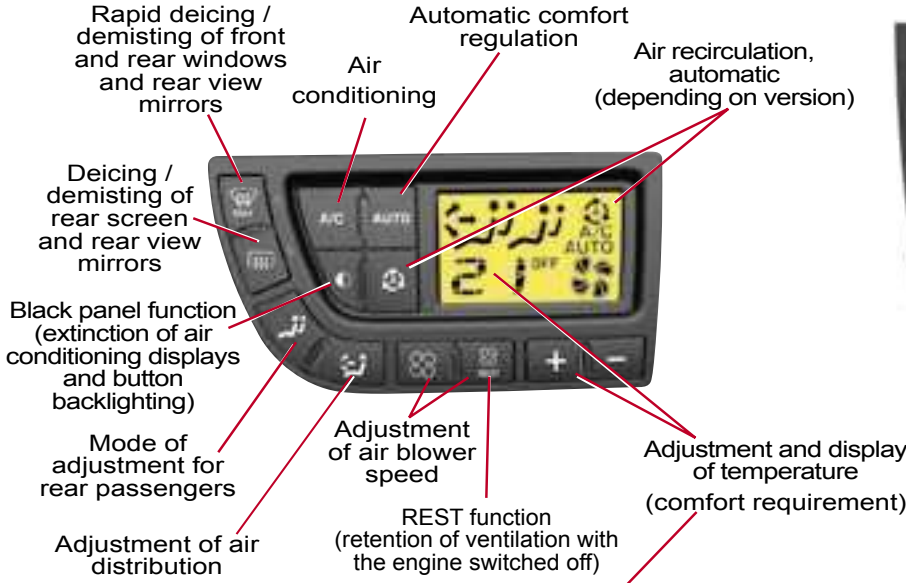

With additional air conditioning (no warm air distribution)



VENTILATION

Heating and manual air conditioning

DRIVER'S CONTROL PANEL

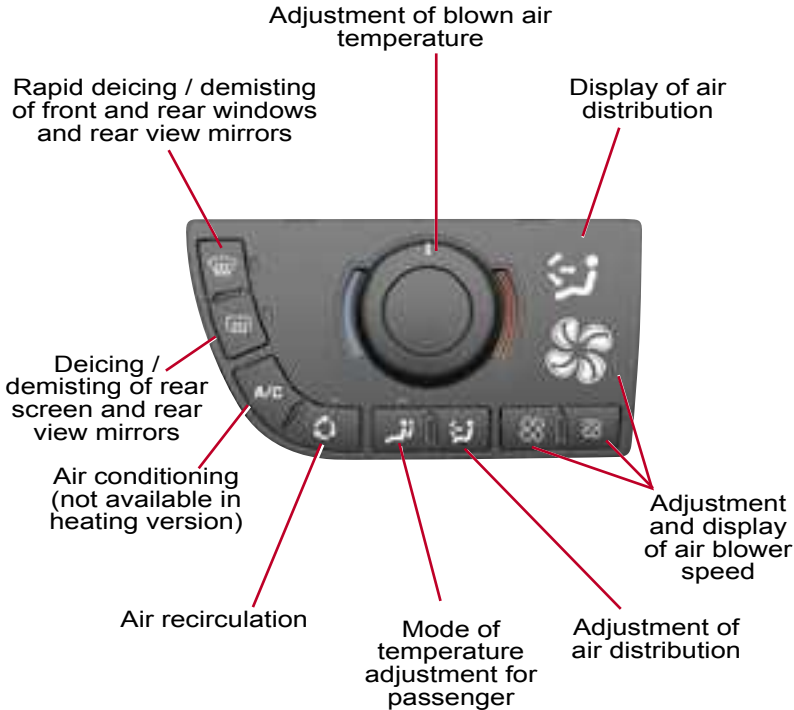

PASSENGER'S CONTROL PANEL

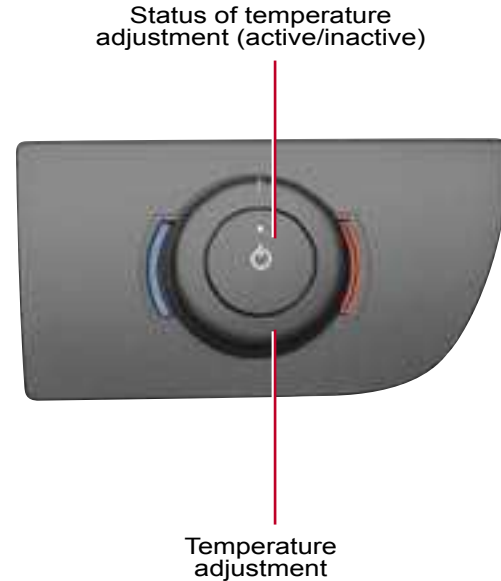

MONITORING



Seat belts not fastened / unfastened warning lamp

This warning lamp informs you if the front passenger's seat belt is not fastened / unfastened and if the second- and third-row rear passengers' seat belts are unfastened. The lit up positions represent the passengers whose seat belts are not fastened / unfastened.

▶▶ 36



Locking from inside

You can use electrical central locking or unlocking by pressing on button **A**.

If one of the doors is open or is not closed properly, central locking will not work.

Anti-intrusion security

When starting the engine, the system automatically locks the doors once you reach approximately 10 km/h (approximately 6 mph).

▶▶ 98

Tyre deflation detection

This function warns you if a tyre is deflated or punctured.

This system does not absolve the driver of the need to regularly check the tyre pressures.

Deflation warning



The **SERVICE** warning lamp lights up, and a vehicle outline is displayed, accompanied by a message and a sound signal.

Puncture



The **STOP** warning lamp lights up, and a vehicle outline is displayed, accompanied by a message and a sound signal.

▶▶ 190

PASSENGER SAFETY



Deactivation of front passenger airbag

1. Insert key into (A).
2. Select «OFF» position.
3. Remove key.

▶▶ 123



CHILD SAFETY

Manual control

The rear doors are locked by operating the lever (aperture at an angle).



Electric control

Pressing on the button prohibits operation of the electric windows and opening of the rear doors from the rear of the vehicle.

▶▶ 124

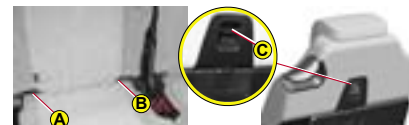

ISOFIX fixing system

The 3 second-row rear seats and the front passenger seat of your vehicle are fitted with regulation ISOFIX anchoring points, with 3 rings for each seat position (A B C).

This fixing system is designed for children weighing up to 18 kg.

▶▶ 128

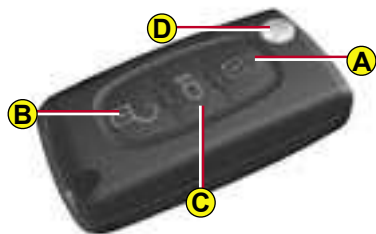

Central unlocking

- A short press on button **B** unlocks your vehicle.

The unlocking is confirmed by the flashing of the direction indicators, and by the disarming of the alarm if the vehicle has one.

The unlocking activates:

- the deployment (to the last position registered) of the exterior rear view mirrors,
- the direction indicator side repeaters (located underneath the exterior rear view mirrors),
- the timed lighting of the interior lamps and the sill lighting for around 30 seconds,
- the timed lighting of the exterior side lighters (located underneath the exterior rear view mirrors) for around 30 seconds.

Note : if none of the doors is opened within thirty seconds following unlocking, the doors automatically relock.

Central locking - Deadlocking

- A short press on button **A** locks your vehicle.
- A long press on button **A** also closes the windows and the panoramic glass roof blind.

The locking is confirmed by the continuous lighting of the direction indicators and the arming of the alarm.

The locking activates:

- folding of the exterior rear view mirrors,
- operation of the guide-me-home lighting, if it is activated,
- the exterior side lighters.

If any of the doors, or the boot, is open or not properly closed, a rebound sound signals to you that it is impossible to lock the vehicle.

For vehicles equipped with deadlocking, two successive presses on button **A** deadlock the vehicle.

It is then impossible to open the doors either from the inside or from the outside.

Selectivity of doors

If you have selected « driver » in the « access to the vehicle » menu of the multifunction screen :

- a press on button **B** opens the driver's door,
- a second press opens all the doors.

This function is not available using the key.

It is dangerous to operate the deadlocking when someone is inside the vehicle because it is impossible to unlock the vehicle from the inside (without the remote control).

When you are closing the windows and/or the panoramic glass roof blind with the remote control, you must make sure that no-one is obstructing them from closing properly.

Guide-me-home lighting

A press on button **C** operates the guide-me-home lighting (lighting of the sidelamps, dipped beams, number plate lamps and side lighters (located underneath the exterior rear view mirrors).

A second press before the end of the timing cancels the guide-me-home lighting.

Vehicle location

To locate the vehicle on a carpark, press button **A**. The location of the vehicle is revealed by :

- the flashing of the direction indicators and side repeaters for a few seconds,
- the lighting of the interior lamps for around 30 seconds,
- the lighting of the side lighters.

The vehicle remains locked.

Foldaway and ejection of the key

Button **D** folds the key in and out of its housing in the remote control.

If you do not press on button **D**, you could damage the mechanism.

Remote control battery spent

This information is given by a message on the multifunction screen, accompanied by a sound signal and the lighting of the SERVICE warning lamp.

Changing the remote control battery

Detach the housing to access the battery.

Battery : CR 0523, 3V.

Re-initialising the remote control

After a change of battery, it is necessary to re-initialise the remote control. For that, switch on the ignition and immediately press button **A** on your remote control until the action desired is triggered. This manoeuvre may take some ten seconds.

Note : Make a careful note of the numbers for your keys and remote control on the ASSISTANCE card. Keep this in a safe place.

Do not throw away spent batteries. Return them to a CITROËN dealer or to an approved collection point (photo shops, etc.).

Simultaneous use of other high frequency equipment (mobile telephones, domestic alarms, etc.) may interfere temporarily with the operation of the remote control. If it malfunctions on a permanent basis, you must re-initialise the remote control.

Except for re-initialisation, the remote control cannot function while the key is in the ignition, even with the ignition switched off.

Be aware that an inadvertent manipulation of the remote control in your pocket could cause the vehicle doors to unlock without your knowledge.

However, if no door is opened within thirty seconds following an unlocking, the doors will automatically relock.

Warning : there is a risk of damage if the replacement battery is not in conformity.

Use only those batteries that are identical or equivalent to those recommended by CITROËN.



Electronic immobiliser key

The key locks and unlocks all the vehicle's doors, as well as switching on the engine.

Note : For security reasons when the ignition is switched off, when the driver's door is opened a sound signal reminds you if you have not removed the key.

The key can also deactivate the front passenger airbag (see «Airbags»).

Central locking with the key

Turn the key briefly in the door lock. The vehicle is locked.

Deadlocking : Central locking with the key

Turn the key a second time in the door lock. The vehicle is deadlocked. It is then impossible to open the doors from the inside or from the outside.

A long action with the key closes the windows.

Note : With the vehicle stationary and the engine switched off, locking is signalled by the flashing of the warning lamp on the interior locking control.

If any of the doors, or the boot, is open or not properly closed, a rebound sound signals to you that it is impossible to lock the vehicle.

Electronic immobiliser

The ELECTRONIC IMMOBILISER locks the vehicle's supply system.

The system activates automatically when the key is removed from the ignition.

All the vehicle keys contain an electronic immobiliser device.

After you switch on the ignition, a dialogue is established between the ignition key and the electronic immobiliser device.

If the key is not recognised, starting is impossible.

If this happens, leave your vehicle immobilised and contact a CITROËN dealer.



It is dangerous to operate the deadlocking when someone is inside the vehicle because it is impossible to unlock the vehicle from the inside (without the remote control).

The number of the key is on the label supplied with the key. In the case of loss, only a CITROËN dealer can provide you with new keys or remote controls.



A confidential card is given to the new owner when he takes delivery of his new vehicle.

This card bears a hidden access code for the use of the CITROËN dealer when servicing the electronic immobiliser device.

Do not scratch the confidential strip, the security of the immobiliser system depends on the information below remaining covered.

Should the card be lost, your immobiliser system can no longer be considered secure.

In the event of a change of vehicle ownership, it is essential for the new owner to possess the CODE card.
Never leave it in the vehicle.

Advice

Keep the code card bearing your personal electronic immobiliser number in a safe place (never in the vehicle).

If any key modifications become necessary (addition, cancellation or replacement of the key), it is essential to take the confidential card together with all the keys to a CITROËN dealer.



Never attempt to modify the electronic immobiliser's electrical circuit, as that could render your vehicle undriveable.

Should the confidential card become lost, a CITROËN dealer would have to undertake a major repair.



Your vehicle may be equipped with an ANTI-INTRUSION ALARM.

This provides :

- Exterior perimeter protection by means of detectors on the vehicle access points (doors, boot, bonnet) as well as on the electrical supply.
- Interior volumetric protection by means of ultrasonic sensors (detecting movement inside the passenger compartment). This can be deactivated using the control **1**.



The installation also has a siren, and a warning lamp on the control **1** which is visible from outside the vehicle, indicating the three possible statuses of the alarm:

- Alarm not active (disarmed), warning lamp off.
- Alarm active (armed), the warning lamp flashes slowly.
- Alarm triggered (signalling an intrusion), the warning lamp flashes rapidly if the alarm is disarmed by a press on the control **B**. It stops as soon as you switch on the ignition.

Note : If there is a malfunction, the warning lamp remains permanently on.

DISARMING OF THE ALARM USING THE REMOTE CONTROL

The alarm is disarmed when you unlock the vehicle (with a press on button **B** on the remote control).

DISARMING OF THE ALARM WITH THE KEY

Unlock the doors with the key. The siren triggers. Enter the vehicle, insert the key in the ignition and turn it to the drive position to stop the siren. Otherwise the siren will continue for approximately 30 seconds.

OPERATION OF THE ALARM

First make sure all the doors are closed.

The alarm is armed by pressing button **A** on the remote control.

With the alarm armed, the protections are active after 5 seconds (perimeter) and 45 seconds (volumetric).

When the alarm is armed (on standby), any intrusion will trigger the siren for 30 seconds, accompanied by the direction indicators lighting up.

The alarm then goes back on standby, but the triggering remains memorised and is signalled by the rapid flashing of the warning lamp on control **1** after you have deactivated the alarm with a press on the unlocking button **B**. The flashing stops when you switch on the ignition.

The siren is also triggered if there is a cutting of the electrical supply. To stop it, restore the electrical supply then press on the unlocking button **B**.

Note :

- If you want to lock your vehicle without arming the alarm, just lock with the key only.
- If you try to lock your vehicle but a door, or the boot, is still open, the central locking does not operate but the alarm will arm itself after approx. 45 seconds. You will hear a rebound sound coming from the locks.

Note : The siren is automatically deactivated (for example for disconnecting the battery) as soon as the vehicle is unlocked using the remote control

Deactivation of the volumetric detection

You can operate the alarm with perimeter protection only, by deactivating the volumetric protection (if for example you wish to leave an animal in the vehicle).

For this, switch off the ignition then immediately press button **1** for at least one second.

The warning lamp on button **1** should come permanently on. It will start to flash when the alarm is armed.

Arm the alarm by locking your vehicle with the remote control.

It is recommended to disarm the volumetric detection when you use an automatic car wash, to prevent random triggering of the alarm.

Automatic activation (according to destination)

The alarm is armed automatically, 2 minutes after the last door, or the boot, has been closed.

In order to prevent the alarm from triggering when you open one of the doors or the boot, it is essential to press the unlocking button **B** again on the remote control.

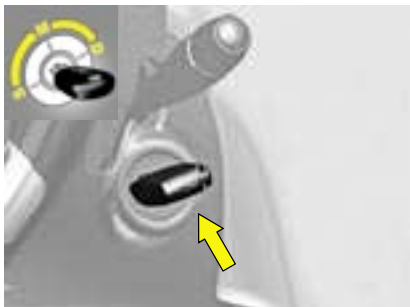

• S : Steering lock

To unlock the steering, gently move the steering wheel while turning the key, without forcing it.

• M : Drive position

Depending on the version of your vehicle, the following warning lamps should also come on for a short time :



Test with the key in the ignition position

• D : Starter

Release the key as soon the engine has started. Never action the key while the engine is already running.

Steering lock

S : After removing the key, turn the steering wheel to lock the steering. The key can only be removed in position **S**.

M : Ignition switched on, the steering is unlocked (by turning the key to position **M**, move the steering wheel gently if necessary).

D : Starter position.

Starting and stopping the engine : see « Starting ».

Economy mode

To ensure engine starting, in certain situations the vehicle goes into economy mode.

The electrical components relating to comfort and lighting of headlamps (except side markers) are automatically cut off.

To reactivate them, it will be necessary to restart the engine.

Note : When the vehicle goes into economy mode, a message displays.



NEVER REMOVE THE IGNITION KEY BEFORE THE VEHICLE HAS COME TO A COMPLETE STOP. IT IS ESSENTIAL ALWAYS TO KEEP THE ENGINE RUNNING IN ORDER TO RETAIN BRAKING AND STEERING ASSISTANCE (risk of triggering the steering lock and rendering the safety features inoperative).

When stationary, having removed the key, turn the steering wheel gently if necessary to ensure that the steering lock engages.

DASHBOARD

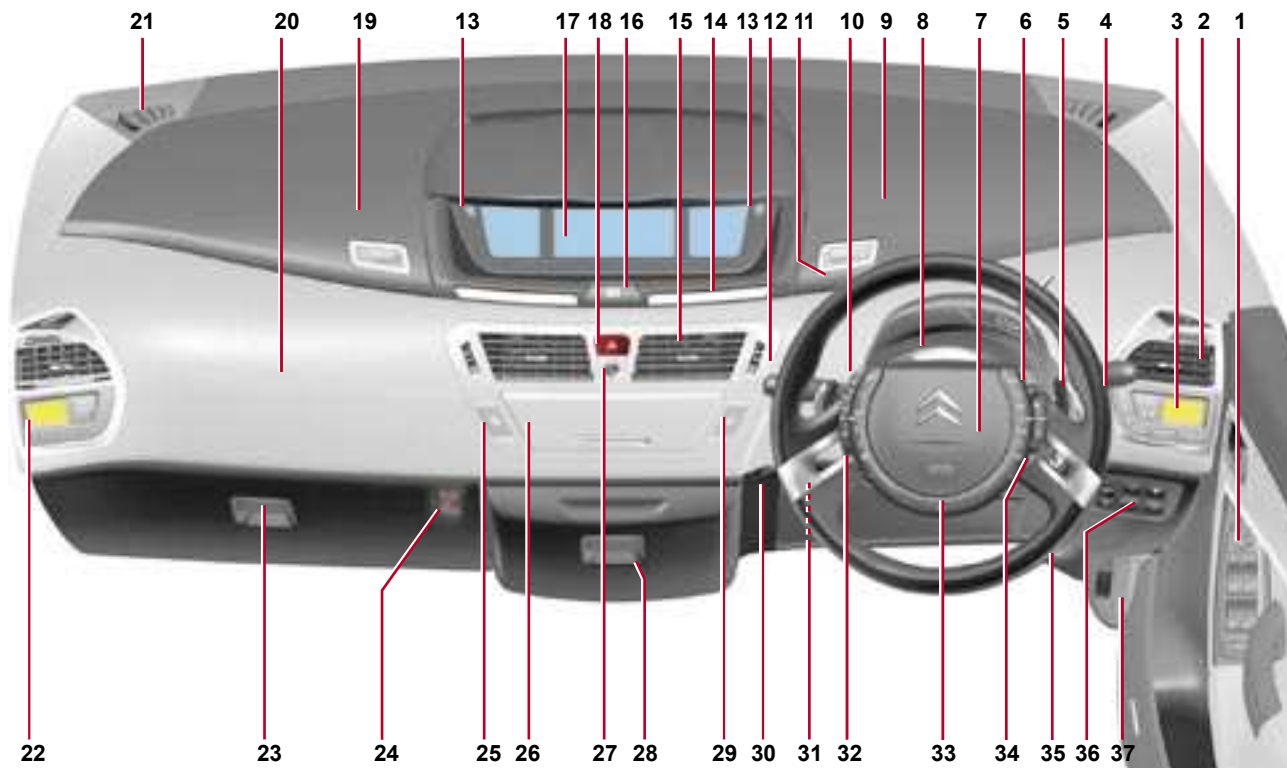

- 1** Side air vent
- 2** Loudspeaker (Tweeter) (right and left)
- 3** Passenger's airbag
- 4** Right hand upper storage
- 5** Controls :
 - Trip mileage recorder reset button
 - Lighting rheostat
 - Colour (choice of background colour)
 - Personalisation
- 6** Instrument panel
- 7** Hazard lamps control
- 8** Automatic electronic parking brake
- 9** Central air vents
- 10** Warning lamps display
- 11** Controls :
 - Lighting
 - Direction indicators
 - Front and rear foglamps
- 12** Gear controls
- 13** Cruise control and speed limiter (controls on steering wheel)
- 14** Left hand upper storage
- 15** Direction indicator warning lamps
- 16** Driver's airbag
- 17** Radio-CD controls on steering wheel
- 18** Selector/controls for automatic gearbox or electronic gearbox system (6 speed)
- 19** Controls :
 - Windscreen wipe
 - Screen wash
 - Rear screen wipe
 - Trip computer
- 20** Driver's air conditioning controls
- 21** Controls :
 - Rear view mirrors
 - Windows
 - Child safety
- 22** Bonnet release
- 23** Controls :
 - Fuel flap
 - Parking assistance
 - Lane departure warning system
 - Alarm deactivation
 - Headlamps adjustment
- 24** Steering lock - ignition
- 25** Controls for multifunction display (on steering wheel)
- 26** Horn
- 27** Optional function controls (on steering wheel)
- 28** Ambiance lighting control
- 29** Central locking button
- 30** Refrigerated storage
- 31** Scented air freshener
- 32** Radio-CD
- 33** ESP deactivation button
- 34** Key switch :
 - Passenger's airbag activation/deactivation
- 35** Lower glovebox :
 - Air freshener clips
 - Various storage
- 36** Fusebox access flap
- 37** Passenger's air conditioning controls

INSTRUMENT PANELS

The instrument panel groups all the driving and comfort information at the centre of the dashboard.

Mono-tone instrument panel with multifunction screen A



Bi-tone instrument panel with multifunction screen C



NaviDrive instrument panel with multifunction screen DT



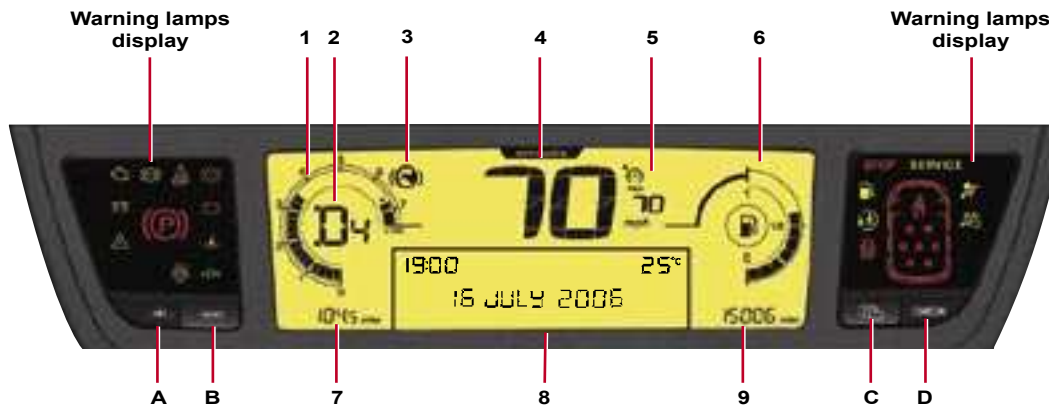

CENTRAL DISPLAY

1. Rev counter
2. Gearbox information
3. « Foot on brake » warning lamp
4. Speed indicator
5. Cruise control or speed limiter reference
6. Fuel gauge

7. Trip mileage recorder
8. Multifunction screen A
9. Maintenance indicator, on switching on ignition, then total mileage recorder

COMMAND BUTTONS

- A. Lighting rheostat (available day and night)
- B. Trip mileage recorder reset
- C. Lighting rheostat (available day and night)
- D. Check (list of alerts)

INSTRUMENT PANELS

The instrument panel groups all the driving and comfort information at the centre of the dashboard.

Mono-tone instrument panel with multifunction screen A



Bi-tone instrument panel with multifunction screen C



NaviDrive instrument panel with multifunction screen DT



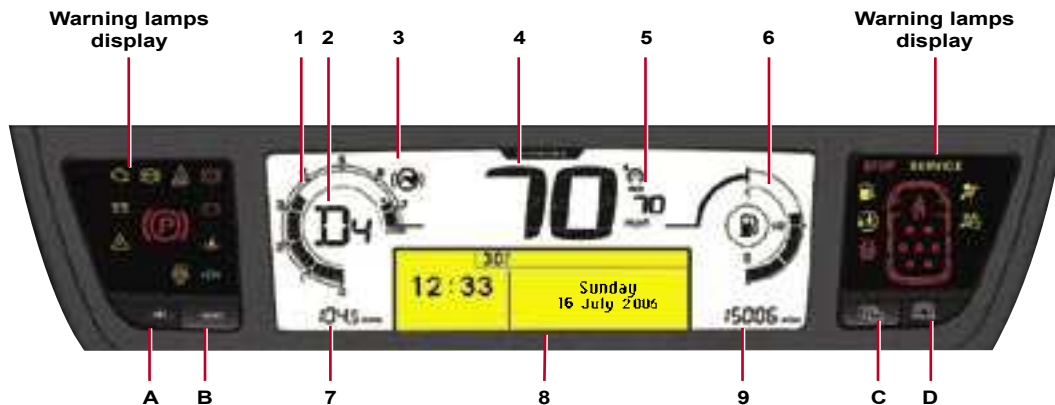

▶▶ 46-49

CENTRAL DISPLAY

1. Rev counter
2. Gearbox information
3. « Foot on brake » warning lamp
4. Speed indicator
5. Cruise control or speed limiter reference
6. Fuel gauge

7. Trip mileage recorder
8. Multifunction screen C
9. Maintenance indicator, on switching on ignition, then total mileage recorder

COMMAND BUTTONS

- A. Lighting rheostat (available day and night)
- B. Trip mileage recorder reset
- C. Personalisation of the instrument panel (display of desired information)
- D. COLOUR (choice of background colour)
This button offers you a whole range of colour backgrounds, from white to blue.

INSTRUMENT PANELS

The instrument panel groups all the driving and comfort information at the centre of the dashboard.

Mono-tone instrument panel with multifunction screen A



Bi-tone instrument panel with multifunction screen C



NaviDrive instrument panel with multifunction screen DT





CENTRAL DISPLAY

1. Cruise control or speed limiter reference
2. Speed indicator
3. NaviDrive display (see NaviDrive instructions)
4. Rev counter
5. « Foot on brake » warning lamp
6. Fuel gauge
7. Trip mileage recorder

8. Maintenance indicator, on switching on ignition, then total mileage recorder
9. Gearbox information

COMMAND BUTTONS

- A. Personalisation of the instrument panel (display of desired information)
- B. COLOUR (choice of background colour)
This button offers you a whole range of colour backgrounds, from white to blue.
- C. Lighting rheostat (available day and night)
- D. Trip mileage recorder reset



Direction indicator and lighting lamps



Left hand direction indicator
See «Signalling»



Right hand direction indicator
See «Signalling»



Foglamps (rear)
See «Signalling»

The direction indicators operate simultaneously when the hazard lamps are activated.



Front foglamps
See «Signalling»



Sidelamps
See «Signalling»



Dipped beams
See «Signalling»



Main beams
See «Signalling»



Imperative stop warning lamp

When this warning lamp comes on, it is essential to stop the vehicle and switch off the engine. Contact a CITROËN dealer.

The warning lamp is accompanied by display on the screen of a Stop symbol.



Warning lamp for low brake fluid level and braking distribution malfunction

When the engine is running, this warning lamp, always in association with the STOP warning lamp, indicates that the brake fluid level is low.

If the warning lamp has come on, stop immediately and contact a CITROËN dealer (See « Brakes »).



Automatic electronic parking brake warning lamp

If this warning lamp comes on permanently, it is confirming that the parking brake is applied.

If it flashes, it is indicating an application or release fault. Urgently contact a CITROËN dealer (See « Automatic electronic parking brake »).



Automatic electronic parking brake fault warning lamp

This warning lamp comes on if there is a malfunction in the automatic electronic parking brake.



Warning lamp for deactivation of the automatic functions of the automatic electronic parking brake

This comes on if the « automatic application » and « automatic release » functions when you switch off the engine are deactivated or faulty.



Battery charge warning lamp

This warning lamp lights up for a short time when you start the engine. It should go off when the engine is running. If it comes on permanently, urgently contact a CITROËN dealer.



Seat belt non-fastening warning lamp (on NaviDrive instrument panel)



Seat belt non-fastening/unfastening warning lamp

This warning lamp informs you if the front passengers' seat belts are non-fastened / unfastened or if the 2nd and 3rd row rear passengers' seat belts are unfastened. The points illuminated represent those passengers whose seat belts are un-fastened / non-fastened.

Driver's and front passenger's seat belts not fastened :

- The warning lamp lights up between 0 and 20 km/h. Above 20 km/h (approx. 12 mph), it flashes accompanied by a screen message and a sound signal for around 120 seconds.

Rear passengers' seat belts not fastened:

- When the ignition is switched on, the points corresponding to the seat positions with seat belts not fastened remain lit up for 30 seconds.

Seat belts unfastened during the journey :

- The point corresponding to the seat position with seat belt unfastened lights up between 0 and 20 km/h. Above 20 km/h (approx. 12 mph), it flashes accompanied by a sound signal for around 120 seconds. The sound signal stops when the ignition is switched off or if a door is opened.

WARNING LAMPS



Warning lamp for detection of a door left open

When the engine is running, it comes on to indicate that a door, the bonnet and/or the boot is open.



Front / side airbag fault warning lamp

See « Airbags ».



Front passenger's airbag deactivation warning lamp

See « Airbags ».



Coolant temperature warning lamp

This comes on each time you switch on the ignition, for a few seconds. If it comes on while the engine is running, this indicates an abnormal increase in the coolant temperature.

It is essential to stop the vehicle.

Check the coolant level, having taken all the appropriate precautions. If the level is satisfactory, contact a CITROËN dealer.



ABS system

The ABS warning lamp comes on when you switch on the ignition and should go off after a few seconds.

If the warning lamp does not go off, there may be a system malfunction (see « Brakes »).



Diesel engine preheater warning lamp

See the procedures for starting the engine.

See the chapter « Starting ».



SERVICE warning lamp

This warning lamp remains on for as long as the fault relating to the alert message is present, this for a serious fault.

Urgently contact a CITROËN dealer.

The warning lamp remains on only temporarily in the case of minor faults.

Contact a CITROËN dealer.

To recall the corresponding alert message, see « Log of alerts ».



Depollution system warning lamp

If it flashes or lights up while you are driving, this indicates a depollution system malfunction.

Urgently contact a CITROËN dealer.



Child safety warning lamp

When you activate the child safety, or each time you switch on the ignition, the warning lamp appears but goes out after 10 seconds (see chapter « Child safety »).



ESP/ASR warning lamp

In operation

While either the ESP or the traction control system is operating, the **ESP/ASR** warning lamp flashes.

In the event of a malfunction

When the vehicle is moving, the lighting of the ESP/ASR warning lamp, accompanied by a message on the multi-function screen and a sound signal, indicates a system malfunction.

Contact a CITROËN dealer.

Deactivation

The lighting of the ESP/ASR warning lamp and the diode on the ESP deactivation button indicates that the system is deactivated.

See «ESP».



Fuel low warning lamp

When the tank is full, all the bars are lit up.

If the fuel low warning lamp comes on accompanied by a beep and a message on the multifunction screen, there are approximately 7 litres of fuel remaining in the tank and 2 or 3 bars flash in the instrument panel.

When the last bar goes out, there are approximately 2 litres of fuel remaining in the tank.

A control located on the panel to the left of the steering wheel allows you to open the fuel flap from inside the vehicle (see « Fuel »).



« Foot on brake » warning lamp

The flashing of this warning lamp on the display informs you that you need to press the brake pedal in order to be able to start the engine on a vehicle with the (6-speed) Electronic Gearbox System, or to quit position **P** in the case of an automatic gearbox.

This warning lamp comes on if you attempt to release the electric parking brake without pressing the brake pedal.

Note : In the case of the Electronic Gearbox System, this warning lamp flashes to indicate overheating of the clutch if you excessively use the accelerator to hold the vehicle on an uphill slope. Use the brake pedal or the electric parking brake.



Parking space warning lamp

This warning lamp comes on when the parking space function is selected.

It flashes while the space is being measured.

When you switch on the ignition, the instrument panel displays :

- the maintenance indicator,
- the engine oil level indicator,
- the total mileage recoder,
- then the trip mileage recoder.

Engine oil level indicator

When you switch on the ignition, the maintenance indicator displays for a few seconds (see « Maintenance indicator »), then the engine oil level is displayed, also for a few seconds.

Note : to make sure that the measurement is reliable, check the oil level on horizontal ground, with the engine having been stopped for at least 15 minutes.

oil ok

This display indicates normal operation.

oil

A flashing of «**OIL**» indicates that the oil level is below minimum.

Check with the manual dipstick. See «Levels». If the low level is confirmed, contact a CITROËN dealer.

oil --

A flashing of «**OIL ----**» indicates a problem with the indicator. Contact a CITROËN dealer.

MAINTENANCE INDICATOR

II

It informs you when the next routine service is due in accordance with the vehicle servicing schedule in the Maintenance Guide. This information is dependent on two parameters: the mileage covered, and the time elapsed since the last visit.

Operation

From switching on the ignition and for a few seconds, the spanner symbolising maintenance operations lights up; the total mileage recorder display tells you the distance remaining to the next service (in thousands and hundreds of kilometres, or miles).

Example : before the next service you can still travel :



A few seconds after that, the total mileage recorder display appears.



Operation if the distance remaining to the next service is less than 1 000 km (approx. 600 miles)

Each time you switch on the ignition and for 5 seconds, the symbol and the distance flash.

Example : There remain up to the next service : 900 km (or miles).

On switching on the ignition and for 5 seconds, the instrument panel indicates :



A few seconds after that, the total mileage recorder display appears and the the maintenance symbol remains lit up.

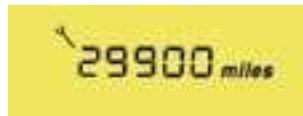

Operation if the service interval has been exceeded

Each time you switch on the ignition, the maintenance symbol and the distance covered (preceded by a minus) beyond the recommended interval flash.

Example : You have passed the service interval by 300 km (or miles).

The routine service on your vehicle needs to be carried as soon as possible.

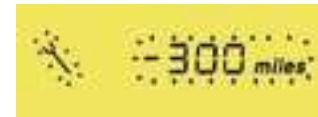

A few seconds after switching on the ignition, the total mileage recorder resumes its normal role and **the maintenance symbol remains lit up**.



MAINTENANCE INDICATOR

Maintenance intervals

If you use your vehicle in particularly difficult conditions, it is essential to have recourse to the service schedule for driving in conditions, comprising shorter intervals between services (see the Maintenance Guide).



Mono-tone or
Bi-tone
instrument panel

NaviDrive
instrument panel



Reset to zero

Your CITROËN technician resets the indicator to zero after each service. However, if you do your own servicing, the procedure for resetting to zero is as follows :

- Switch off the ignition, then turn the key to position **S**, steering lock.
- Press on button **A** and keep it pressed.
- Switch on the ignition.
- Keep button **A** pressed until the screen indicates a zero and the maintenance symbol disappears.
- Switch off the ignition.

MULTIFUNCTION SCREEN A

II

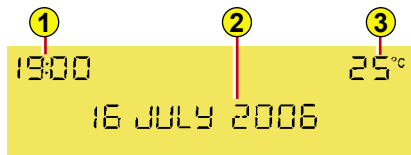

It is recommended that the driver should not manipulate the controls described below while the vehicle is in motion.

- 1 - Time
- 2 - Date and display zone
- 3 - Outside temperature

When the outside temperature is between +3 °C and -3 °C, the display of temperature flashes (ice risk).

Note : The outside temperature displayed may be greater than the actual temperature if the vehicle is parked in bright sunlight.

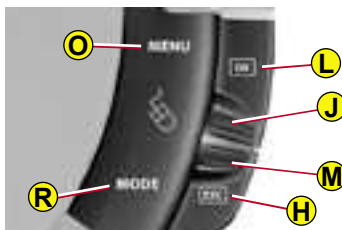

The display of certain types of information is sometimes by scrolling and sometimes by alternation.

Controls

- O** - Access to the « Main Menu »
- J** or **M** - Scrolling in the screen menus
- L** - Validation and Selection in the menus of the function chosen or the value modified
- H** - Cancellation of the operation or return to the previous display
- R** - Selection of the type of information to be displayed in zone 2 (date, radio/CD and trip computer)
- K** or **N** - Within the Menus, choice of activation/deactivation of functions and selection of adjustments

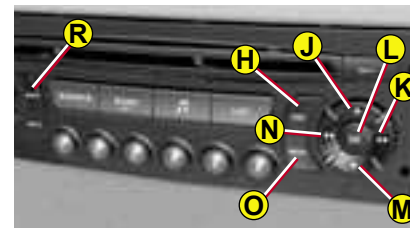

Main Menu

By pressing on the button **O**, then using buttons **J** or **M**, you have access to the following functions :

- **Radio-CD** (see Radio-CD)
- **Vehicle configuration**, to activate/deactivate :
 - operation of the rear wiper
 - automatic guide-me-home lighting (according to version)
 - electronic parking brake automatic functions (application / release)
 - door selectivity
 - lighting of daytime-running lamps (according to country).
- **Options**, for display of alert messages
- **Display adjustments**, for altering the date and the time on the displays
- **Languages**, for choosing the display language
- **Units**, giving you access to the choice of units of Temperature and units of Fuel Consumption

MULTIFUNCTION SCREEN A

PERSONALISATION and CONFIGURATION

To activate/deactivate rear screen wipe when you engage reverse gear :

1. Press on **O**.
2. Use **J** or **M** to select the sub-menu for personalisation-configuration of your vehicle, then confirm your choice with a press on **L**.
3. Select rear wipe by pressing **J** or **M**.
4. The system tells you whether the function status is active or inactive. Modify this status with a press on **K** or **N**.
5. Validate with a press on **L**.

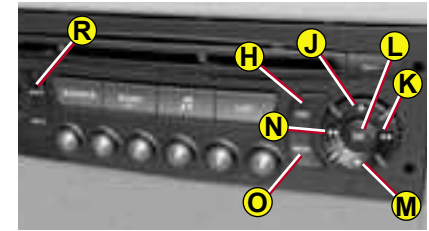
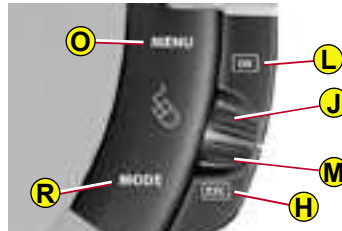

To activate/deactivate the automatic guide-me-home lighting :

1. Press on **O**.
2. Use **J** or **M** to select the sub-menu for configuration of your vehicle, then confirm your choice with a press on **L**.
3. Select guide-me-home lighting, by pressing **J** or **M**.
4. The system tells you whether the function status is active or inactive. Modify this status with a press on **K** or **N**.
5. Validate with a press on **L**.

To activate/deactivate the electronic parking brake automatic functions :

1. Press on **O**.
2. Use **J** or **M** to select the sub-menu for configuration of your vehicle, then confirm your choice with a press on **L**.
3. Select electronic automatic parking brake by pressing **J** or **M**.
4. The system tells you whether the function status is active or inactive. Modify this status with a press on **K** or **N**.
5. Validate with a press on **L**.

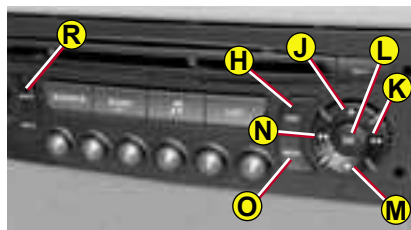
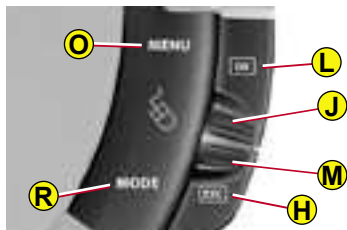

To activate/deactivate door selectivity :

1. Press on **O**.
2. Use **J** or **M** to select the sub-menu for configuration of your vehicle, then confirm your choice with a press on **L**.
3. Select the access point by pressing **J** or **M**.
4. The system tells you the status of the doors/tailgate. Modify this status with a press on **K** or **N**.
5. Validate with a press on **L**.

To activate/deactivate lighting of daytime-running lamps (according to country) :

1. Press on **O**.
2. Use **J** or **M** to select the sub-menu for configuration of your vehicle, then confirm your choice with a press on **L**.
3. Select lighting of daytime-running lamps by pressing **J** or **M**.
4. The system tells you the status (active/inactive) of this function. Modify this status with a press **K** or **N**.
5. Validate with a press on **L**.

MULTIFUNCTION SCREEN A

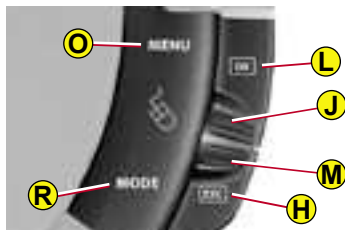

To display the log of alerts :

1. Press on **O**.
2. Use **J** or **M** to select the sub-menu for options. Confirm with two presses on **L**.

Note : You can cancel the start of the display by pressing button **R** to abandon and validating by pressing **L**.

Alerts, signalled previously but not resolved, will scroll in the display for recall.

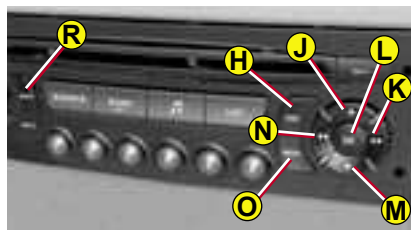

To adjust the date and the time :

1. Press on **O**.
2. Use **J** or **M** to select the sub-menu for Display Adjustments, then confirm by pressing **L**.
3. Press **J** or **M** to select what you want to modify : year, month, day, hour, minutes, mode of display.
4. Make your adjustment by pressing **K** or **N**. You can continue your adjustments by selecting a different element by presses on **J** or **M**. When you have finished your adjustments, press **L**.

To choose the language :

1. Press on **O**.
2. Use **J** or **M** to select the sub-menu for Languages. Confirm your choice with a press on **L**.
3. With presses on **K** or **N**, select the language of your choice, then validate with a press on **L**.

To choose units :

1. Press on **O**.
2. Press **J** or **M** to select the sub-menu for Units. Confirm your choice with a press on **L**.
3. Press **J** or **M** to select the type of unit you wish to modify (Temperature or Fuel Consumption).
4. With presses on **K** or **N**, select the unit of your choice, then validate with a press on **L**.

Note : This choice concerns all the information (Consumption - Speed) appearing on the displays.

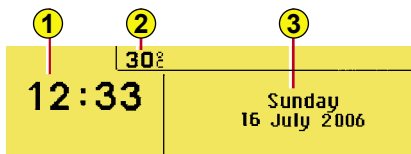

It is recommended that the driver should not manipulate the controls described below while the vehicle is in motion.

- 1 - Time
- 2 - Outside temperature
- 3 - Date and display zone

When the outside temperature is between +3 °C and -3 °C, the display of temperature flashes (ice risk).

Controls

- O** - Access to the «Main Menu»
- J** or **M** - Scrolling in the screen menus
- L** - Validation and Selection in the menus of the function chosen or the value modified
- H** - Cancellation of the operation or return to the previous display
- R** - Selection of the type of information to be displayed permanently (date, radio-CD, trip computer) on the right of the screen

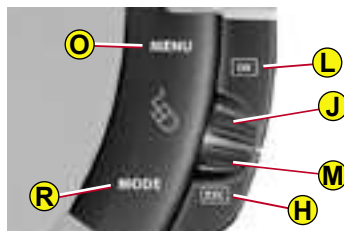

Main Menu

Press on the button **O** to view the «Main Menu» of the multifunction screen. This menu gives you access to the following functions :



Radio-CD
(See Radio-CD)



Trip computer, for :

- Entering the distance to your destination
- Access to the log of alerts (recall of alerts signalled previously)
- Access to the status of functions, such as automatic headlamps and windscreen wipe.



Personalisation - Configuration, for activating/deactivating :

- operation of the rear wiper
- automatic guide-me-home lighting
- Xenon dual-function directional headlamps
- electronic parking brake automatic functions (application / release)
- door selectivity
- lighting of daytime-running lamps and for choosing :
- brightness intensity, time, date and units
- the display language



Bluetooth® hands-free kit
(See Radio-CD)

Note : The outside temperature displayed may be greater than the actual temperature if the vehicle is parked in bright sunlight.

TRIP COMPUTER

To enter the distance to be travelled in the trip computer :

1. Press on **O**.
2. Use **J** or **M** to select the icon for the trip computer, then confirm your choice with a press on **L**.
3. Press **J** or **M** to select entry of distance. Confirm your choice with a press on **L**.
4. To choose the distance, select the figure you wish to modify via **J** or **M**, then confirm your choice with a press on **L**.
5. Using **J** or **M**, adjust the value then validate with a press on **L**.
6. Validate with «OK» on the display.

To access the log of alerts in the trip computer:

1. Press on **O**.
2. Use **J** or **M** to select the icon for the trip computer, then confirm your choice with a press on **L**.
3. Select the log of alerts.
4. When you see the list displayed, scroll down using **J** or **M**.
5. Press on **H**, to return to the permanent display.

To access the status of functions, proceed in a similar manner.

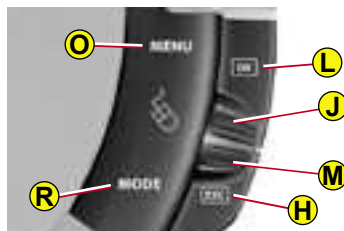

PERSONALISATION and CONFIGURATION

To activate/deactivate rear screen wipe when you engage reverse gear :

1. Press on **O**.
2. Use **J** or **M** to select «Personalisation-Configuration», then confirm your choice with a press on **L**.
3. Then select the sub-menu for vehicle parameters. Confirm your choice with a press on **L**.
4. Using **J** or **M**, select «parking assistance». Confirm your choice with a press on **L**.
5. Then by pressing **L**, select/deselect triggering of rear screen wipe in reverse gear, to activate/deactivate this.
6. Validate with «OK» on the display.

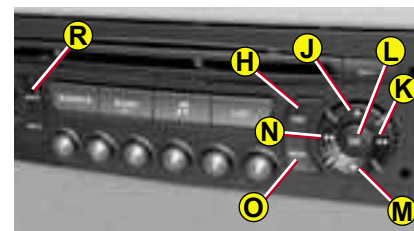

To activate/deactivate the automatic guide-me-home lighting :

1. Press on **O**.
2. Use **J** or **M** to select «Personalisation-Configuration», then confirm your choice with a press on **L**.
3. Then select the sub-menu for vehicle parameters. Confirm your choice with a press on **L**.
4. Using **J** or **M**, select «lighting and signalling». Confirm your choice with a press on **L**.
5. Then by pressing **L**, select/deselect «guide-me-home lighting» to activate/deactivate this. After activation, choose its duration : press on **L**, then use **J** or **M** to select the duration and then press on **L**.
6. Validate with «OK» on the display.

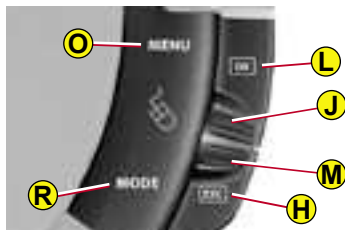

To activate/deactivate the Xenon dual-function directional headlamps :

1. Press on **O**.
2. Use **J** or **M** to select «Personalisation-Configuration», then confirm your choice with a press on **L**.
3. Then select the sub-menu for vehicle parameters. Confirm your choice with a press on **L**.
4. Using **J** or **M**, select « driving assistance ». Confirm your choice with a press on **L**.
5. Then by pressing **L**, select/deselect Xenon dual-function directional headlamps to activate/deactivate them.
6. Validate with «**OK**» on the display.

To activate/deactivate the electronic parking brake automatic functions (application/release) :

1. Press on **O**.
2. Use **J** or **M** to select «Personalisation-Configuration», then confirm your choice with a press on **L**.
3. Then select the sub-menu for vehicle parameters. Confirm your choice with a press on **L**.
4. Using **J** or **M**, select « driving assistance ». Confirm your choice with a press on **L**.
5. Then by pressing **L**, select/deselect «automatic parking brake» to activate/deactivate the electronic parking brake automatic functions (application/release).
6. Validate with «**OK**» on the display.

To activate/deactivate the door selectivity :

1. Press on **O**.
2. Use **J** or **M** to select «Personalisation-Configuration», then confirm your choice with a press on **L**.

3. Then select the sub-menu for vehicle parameters. Confirm your choice with a press on **L**.
4. Using **J** or **M**, select «access to the vehicle». Confirm your choice with a press on **L**.
5. Then by pressing **L**, select the status of the vehicle access as desired.
6. Validate with «**OK**» on the display.

To activate/deactivate lighting of daytime-running lamps (according to country) :

1. Press on **O**.
2. Use **J** or **M** to select «Personalisation-Configuration», then confirm your choice with a press on **L**.
3. Then select the sub-menu for vehicle parameters. Confirm your choice with a press on **L**.
4. Using **J** or **M**, select «lighting and signalling». Confirm your choice with a press on **L**.
5. Then by pressing **L**, select/deselect «daytime-running lamps» to activate/deactivate the function.
6. Validate with «**OK**» on the display.

MULTIFUNCTION SCREEN C

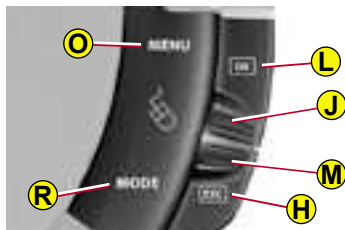

To adjust the date and the time :

1. Press on **O**.
2. Use **J** or **M** to select «Personalisation-Configuration», then confirm your choice with a press on **L**.
3. Select the display configuration using **J** or **M**. Confirm with a press on **L**.
4. Select the adjustment for the date and the time, using **J** or **M**. Confirm with a press on **L**.
5. Press **J** or **M** to select the values you wish to modify. Confirm your choice with a press on **L**.
6. Make your adjustments by pressing **J** or **M**, validating each adjustment choice by pressing **L**.
7. Validate with «**OK**» on the display.

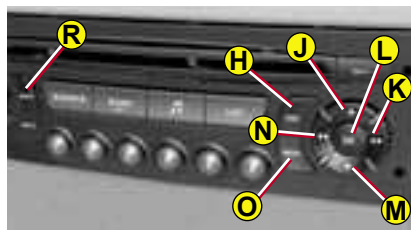

To choose the units :

1. Press on **O**.
2. Use **J** or **M** to select «Personalisation-Configuration», then confirm your choice with a press on **L**.
3. Select the display configuration using **J** or **M**. Confirm with a press on **L**.
4. Then select the sub-menu for units. Confirm your choice with a press on **L**.
5. Using **J** or **M**, select the unit you wish to modify (Temperature or Consumption), then validate by pressing **L**.
6. Validate with «**OK**» on the display.

Note : This choice concerns all the information (Consumption - Speed) appearing on the displays.

To choose the language :

1. Press on **O**.
2. Use **J** or **M** to select «Personalisation-Configuration», then confirm your choice with a press on **L**.
3. Make your choice of language, using **J** or **M**.
4. Using **J** or **M**, select the language and validate your choice with a press on **L**.
5. Validate with «**OK**» on the display.

MULTIFUNCTION SCREEN DT

II



It is recommended that the driver should not manipulate the controls described below while the vehicle is in motion.

- 1 - Outside temperature
- 2 - Directory
- 3 - Date
- 4 - Telephone
- 5 - Time

When the outside temperature is between +3 °C and -3 °C, the display of temperature flashes (ice risk).

Note: The outside temperature displayed may be greater than the actual temperature if the vehicle is parked in bright sunlight.

Controls

- O** - Access to the «Main Menu»
- J** or **M** - Scrolling in the screen menus
- L** - Validation and Selection in the menus of the function chosen or the value modified

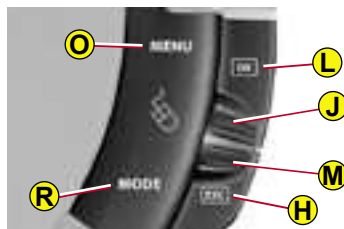

- H** - Cancellation of the operation or return to the previous display
- R** - Selection of the type of information to be displayed permanently (date, radio-CD, trip computer) on the right of the screen

Main Menu

Press on the button **O** to view the «Main Menu» of the multifunction screen.

This menu gives you access to the following functions :



Navigation/guidance
(See NaviDrive instructions)



Audio
(See NaviDrive instructions)



Trip computer
(See NaviDrive instructions)

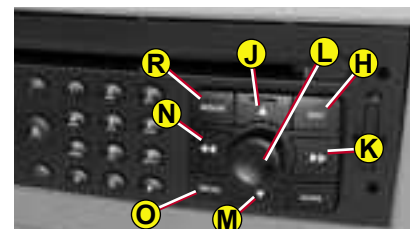

Directory
(See NaviDrive instructions)



Telematics
(See NaviDrive instructions)



Configuration, for adjusting various parameters (date, time, units)
(See NaviDrive instructions)



Map
(See NaviDrive instructions)



Video
(See NaviDrive instructions)

TRIP COMPUTER



To access display and selection of the various types of information, give short presses on the end of the windscreen wiper control stalk.

For multifunction screen C and DT, a press on the «Mode» button will display the trip computer information permanently.

To reset the trip computer information to zero, press continuously for a few seconds on the end of the control stalk when one of the types of information is displayed.



Multifunction screen A

The trip computer gives you 5 types of information accessible by successive presses on the control stalk.

- Range
- Instantaneous consumption
- Distance travelled
- Average consumption
- Average speed

To cancel the display of the trip computer information, press a fifth time.



Multifunction screens C and DT

The trip computer gives you access to 3 types of instantaneous information :

- Range
- Instantaneous consumption
- Distance remaining to be travelled

It also gives you access to 3 types of information for two Journeys 1 and 2 :

- The distance travelled
- The average consumption
- The average speed

The Journeys

Journeys 1 and 2 are independent of each other but identical in use. For example they allow you to allocate journey 1 for daily calculations and journey 2 for monthly calculations.

Setting a Journey to zero

When the relevant Journey is displayed, give a long press on the end of the wiper control stalk.

Version for multifunction screen A



Range

This is the number of kilometres (or miles) that can still be travelled on the fuel remaining in the tank. When the distance remaining to be travelled is less than 25 km (around 15 miles), only three dashes will be displayed.

After a re-initialisation of the trip computer, the indication of range only becomes significant after a certain length of time.

Instantaneous consumption

This is the result based on consumption recorded in the last two seconds. This function only operates above 30 km/h (approx. 20 mph).

Distance travelled

This is the number of kilometres (or miles) travelled since the last time the trip computer was reset to zero.

Average consumption

This is the relationship between the fuel consumed and the distance travelled since the last time the trip computer was reset to zero.

Average speed

This is the result (since the last time the trip computer was reset to zero), from dividing the distance travelled by the time taken (time with the ignition switched on).

Distance remaining to be travelled

To enter this, see « Multifunction screens C and DT ».

Version for multifunction screens C and DT

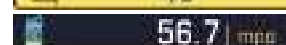
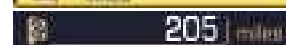
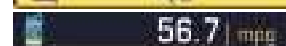
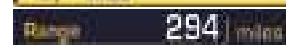

FIXED CENTRED CONTROLS STEERING WHEEL

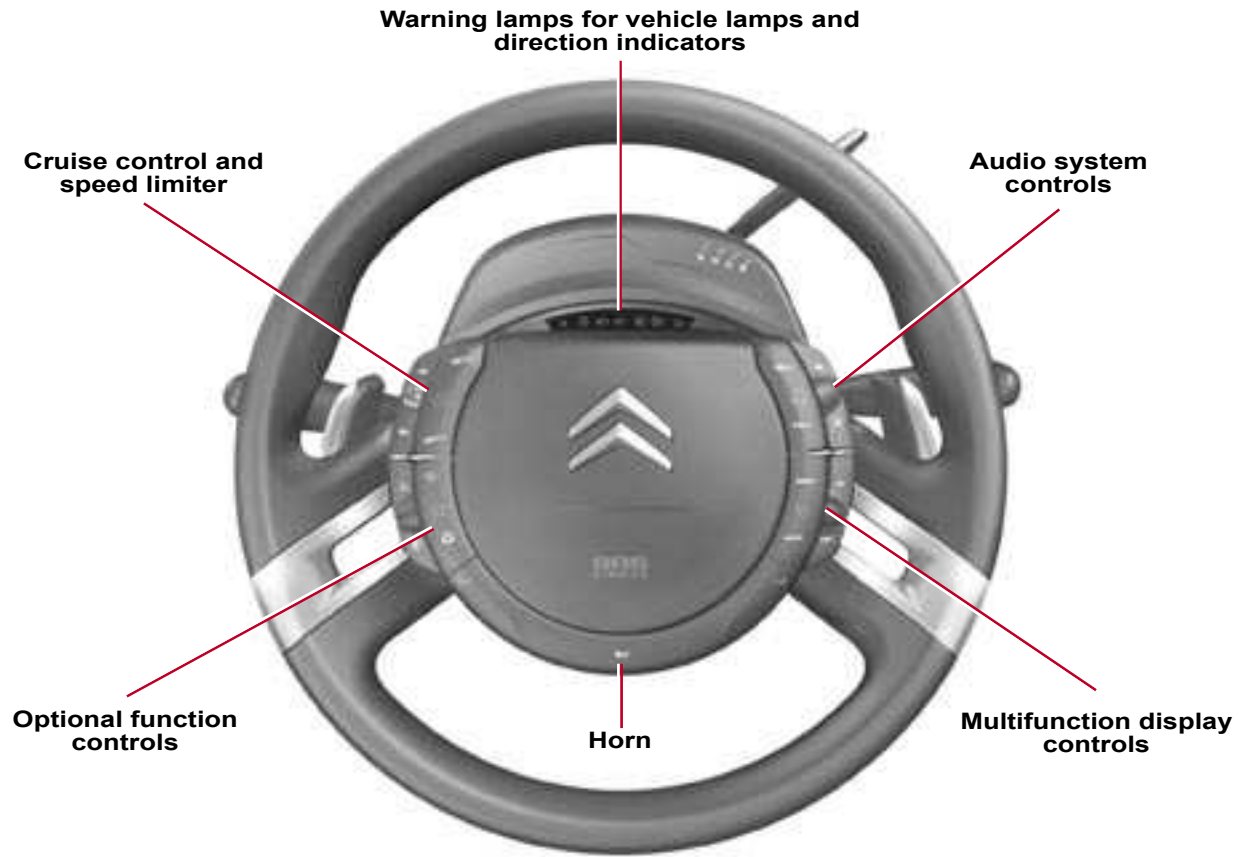

CRUISE CONTROL AND SPEED LIMITER

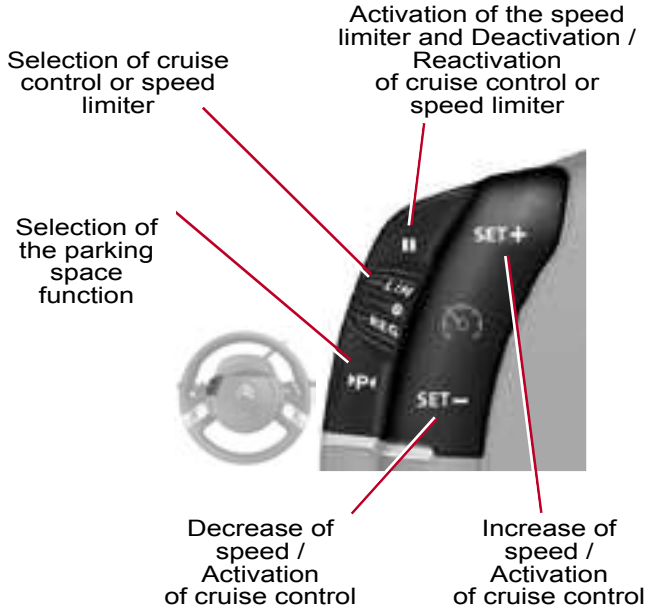

AUDIO SYSTEM CONTROLS

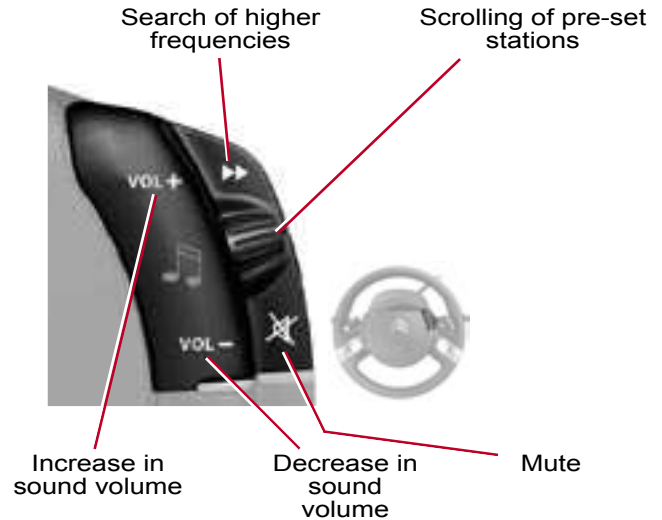

See chapter on Radio or NaviDrive instructions

OPTIONAL FUNCTION CONTROLS

Rheostat for dashboard lighting (instrument panel + controls)

Start of voice recognition (see chapter on Radio - NaviDrive instructions)

Air recirculation

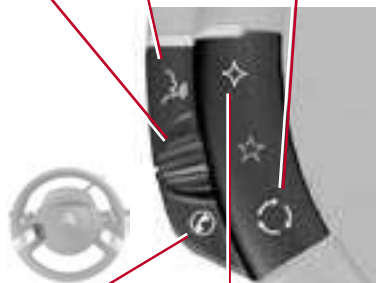

Pick-up / hang-up telephone (see NaviDrive instructions)

Display of « Directory » menu (see chapter on Radio)

Personalisation button :

- Illumination / extinction of interior lamp or
- Diagnosis or
- Personalisation of display of information in the instrument panel or
- Choice of background colour for the instrument panel.

To view the personalisation menu via this button, give it a long press.

MULTIFUNCTION DISPLAY CONTROLS

Validation of the function chosen or of the value modified

Pick-up / hang-up (see chapter on Radio)

Access to the « Main menu » *

Scrolling in the multifunction display



Selection of the type of information to be displayed on the right of the screen (radio, trip computer, navigation / guidance, etc.) and for multifunction screen **A**, choice of activation / deactivation of your functions and adjustment choices

Cancellation of the current operation or return to the previous display

* To comply with legislation in certain countries, the «Menu» control may be deactivated while the vehicle is in motion.

Manual gearbox

1. Check that you are in neutral.
2. Do not touch the accelerator.
3. For Diesel engines : turn the key as far as position **M**. Wait for the preheater warning lamp to go off if this has come on.
4. Action the starter by turning the key until the engine starts (not more than ten seconds).
5. In ambient temperatures lower than 0°C, declutch during the action on the starter to facilitate starting. Then remove your foot slowly from the clutch pedal.

Electronic Gearbox System (6-speed)

1. Check that you are in position **N**.
2. Press firmly on the brake pedal.
3. Do not touch the accelerator.
4. For Diesel engines : turn the key as far as position **M**. Wait for the preheater warning lamp to go off if this has come on.
5. Action the starter by turning the key until the engine starts (not more than ten seconds).

Note : After the vehicle has had a prolonged stop or if the brake pedal has been applied several times when stationary, it is necessary to press the brake pedal fully down in order to authorise starting of the engine.

Automatic gearbox

1. Check that you are in position **P** or **N**.
2. Do not touch the accelerator.
3. For Diesel engines : turn the key as far as position **M**. Wait for the preheater warning lamp to go off if this has come on.
4. Action the starter by turning the key until the engine starts (not more than ten seconds).

Note : To exit from position **P**, press on the brake pedal before moving the selector.



Advice

Vehicles equipped with a turbocharger

Never stop the engine without having allowed it to run for a few seconds at idle, this being the time required for the turbocharger to return to a normal speed.

«Flicking the accelerator» at the moment of switching off the ignition could cause serious damage.

Note : If the engine fails to start at the first attempt, switch off the ignition. Wait ten seconds, then action the starter again as indicated above.



NEVER RUN THE ENGINE IN A SPACE THAT IS ENCLOSED OR INSUFFICIENTLY VENTILATED.



5 speed gearbox

Reverse gear

Never engage reverse gear before the vehicle has come to a complete halt. The movement should be made slowly in order to prevent snatching noises.

Note : With a manual gearbox :

- the cruise control is active from 4th gear above speeds of 40 km/h (25 mph),
- the speed limiter is active above speeds of 30 km/h (19 mph).



The (6-speed) electronic gearbox offers you a choice of two driving modes :

- automatic mode,
- manual mode, with levers under the steering wheel 1.

Mode selection :

- automatic mode : selector 2 in position **A**.
- manual mode : selector 2 in position **M**.

Note : in automatic mode, instant manual operation is possible any time you action one of the levers 1.

Selection position

- The selector position is displayed in the instrument panel, on the left on multifunction screens A and C and on the right on multifunction screen DT.
- A background-lit position grille associated with the selector allows you to view the position selected.



When the ignition is on, lighting of the SERVICE warning lamp, accompanied by a sound signal and the message « Gearbox faulty » indicates a malfunction. Urgently contact a CITROËN dealer.

For safety :

- Position **N** can only be disengaged if you are pressing the brake pedal.
- When a door is opened, a sound signal is heard if the selector is not in position **N**.
- If the gearbox is in position **N** but the selector position is different, reposition the selector on **N** in order to be able to start.



Starting the engine

1. To start the engine, the selector has to be in position **N**.
2. Press firmly on the brake pedal.
3. Action the starter.
4. When the engine is running, place the selector on **R**, **A** or **M** as desired.
5. Check, in the instrument panel, the position engaged.
6. Release the brake pedal and accelerate.

Note : If the selector is not in position **N**, and/or if the brake pedal is not pressed, the corresponding warning lamp(s) display and a message informs you that at least one of these two conditions is not met.

In this case, the engine will not start, recommence the above procedure.

Using the 6-speed electronic gearbox



R Reverse gear

Engaging reverse gear

To engage reverse gear, move the selector to **R**.

Only attempt to change to reverse gear when the vehicle is stationary.

If the vehicle is moving rapidly, if an inadvertent attempt to engage reverse gear is made, the warning lamp **N** will flash and your vehicle will go automatically into neutral. To re-engage a gear, you have only to reposition the selector on **A**, **M** or **R**.



N Neutral

Changing to neutral

To change to neutral, move the selector to **N**. If the vehicle is moving, do not select this position even momentarily.



A Automatic mode

Changing to automatic mode

To change to automatic mode, move the selector to **A**.



M Manual mode

Changing to manual mode

Manual mode activates when you move the selector to **M**.

- Pull the lever « + » to change up a gear.
- Pull the lever « - » to change down a gear.

**When the engine is running, before accelerating to move the vehicle, make sure that the position engaged on the selector grille or in the instrument panel is either :
R, A or M.**

Do not leave the vehicle with the engine running in R, A or M.

II



To select automatic driving mode :

- Move the selector to position **A**. The warning lamp **A** lights up in the instrument panel to confirm the selection.

The gearbox then functions in automatic mode, without any intervention on your part.

It constantly selects the gear that is best suited to the following parameters :

- driving style,
- road profile,
- optimum fuel consumption.



Temporary manual operation when in automatic mode

- By pulling either of the levers « + » or « - », you can exercise temporary control over the changing of gears. The request to change gear will be taken into account. You will still be in automatic mode. The warning lamp **A** remains lit up in the instrument panel.
- This function enables you to anticipate certain situations such the approach of a bend or the need to overtake another vehicle.

Cancellation of automatic mode

The change from position **A** (driving in automatic mode) to position **M** (driving in manual mode) or vice versa can be made at any time. The warning lamp **A** disappears in the instrument panel.



To select manual mode :

- Move the selector to position **M**.

Controls under the steering wheel

The levers under the steering wheel give you access to all the six forward gears.



To change gear :

- Pull the lever « + » to change up a gear.
- Pull the lever « - » to change down a gear.

Note : The levers do not permit you to select neutral or reverse gear, or to exit reverse gear.

Observations :

- If the vehicle stops or reduces speed (for example when approaching a stop sign), the gearbox changes down automatically to first gear.
- In manual mode, it is not necessary to release the accelerator completely during gear changes.
- A request to change gear is accepted only if the engine speed permits it.
- For safety reasons, depending on the engine speed, a change down may be performed automatically.



In situations of high engine speeds (heavy acceleration), a change up will not occur unless the driver actions this on the lever controls.



Acceleration

For optimum acceleration (to overtake another vehicle, you have only to apply the accelerator beyond the end-of-travel switch, by pressing the accelerator pedal firmly.

Vehicle stationary with the engine running

In the event of a prolonged stop with the engine running, the gearbox changes automatically to neutral **N**.

Stopping the engine

Before stopping the engine, you can choose :

- to leave the vehicle in neutral : move the selector to position **N**.
- to leave the vehicle with a gear engaged (**R**, **A** or **M**) : Place the selector in the chosen position prior to stopping the engine. In this case, the vehicle cannot be moved.

In all cases, it is essential to apply the parking brake. Check that the parking brake warning lamp is lit up in the instrument panel.

Do not use the accelerator to hold your vehicle on a gradient. Use either the brake pedal or the electric parking brake.

Before taking any action in the engine compartment, check that the selector is in



The automatic gearbox gives you a choice of two driving modes :

- **automatic mode,**
- **sequential mode.**



Multifunction display A



Multifunction display DT

Selector position

The position of the selector is displayed in the instrument panel, on the left on multifunction screens **A** and **C**, on the right on multifunction screen **DT**. A position grille relating to the selector allows you to view the position that is selected.

Mode selection :

- automatic mode : selector **1** in position **D**.
- sequential mode : selector **1** in position **M**.

For safety :

- Position **P** can be disengaged only if you press the brake pedal.
- When a door is opened, a sound signal is heard if the selector is not in position **P**.
- Always make sure that the selector is in position **P** before you leave your vehicle.

If the gearbox is in position **P** but the position of the selector is different, reposition the selector on **P** so that you can start the vehicle.



Starting the engine

1. To start the engine, the selector has to be in position **P** or **N**.
2. Action the starter.
3. When the engine is running, place the selector on **R**, **D** or **M** as required.
4. Check, in the instrument panel, the position engaged.
5. Release the brake pedal and accelerate.

Note :

- If the selector is not in position **P**, a message « place automatic gearbox in position **P** » appears on the multifunction screen, accompanied by a beep and the flashing of **P** in the instrument panel.

- To avoid incoherence between the position of the selector and the actual position of the gearbox, always exit from position **P** when you switch on the ignition and press the brake pedal. Otherwise, when the ignition is on or the engine is running :
 1. Reposition the selector in position **P**,
 2. Put your foot on the brake pedal and then select the gear you want.

Using the automatic gearbox



P Park

This position of the selector is used to prevent the vehicle from moving when you are stationary.

- To select position **P**, move the selector back to the highest position (towards **R**), then push it forwards and then to the left.

- To exit position **P**, move the selector to the right and then to the position you want.
- Only engage this position when the vehicle is completely stationary. In this position, the front wheels are locked. Make sure that the selector is correctly positioned.



R Reverse gear

Only engage this position when the vehicle is stationary. To prevent snatching, do not accelerate too soon after selection.



N Neutral

Never select position **N** if the vehicle is moving.



Never select positions **P or **R** if the vehicle is not stationary.**

If, while the vehicle is moving, position **N is engaged inadvertently, allow the engine to idle before engaging position **D** or **M**.**



Automatic mode

- Move the selector to position **D**.

The gearbox constantly selects the gear that is best suited to the following parameters :

- driving style,
- road profile
- vehicle load.

The gearbox is then operating in **auto-adaptive** mode, without requiring any intervention on your part.

For certain manoeuvres (for example overtaking), you can obtain maximum acceleration by pressing the accelerator pedal hard down, which then produces an automatic change down to a lower gear.

Observations :

When braking, the gearbox may change down automatically in order to provide effective engine braking.

If you lift your foot off the accelerator abruptly, the gearbox will not engage a higher gear.

Temporary manual operation when in automatic mode

By pulling either of the levers « + » or « - », you can exercise temporary control over the changing of gears. The request to change gear will be taken into account. You will still be in automatic mode. The warning lamp **D** remains lit up in the instrument panel.

This function enables you to anticipate certain situations such the approach of a bend or the need to overtake another vehicle.



- A request to change gear is accepted only if the engine speed permits it.
- For safety reasons, depending on the engine speed, a change up or down may be performed automatically.
- It is possible at any time to move from position **D** (driving in automatic mode) to position **M** (driving in sequential mode) or vice versa.

M Sequential mode with manual gear changing

Position of the selector for manual gear changing.

- Move the selector to position **M**.
- Pull the lever « + » to change up a gear.
- Pull the lever « - » to change down a gear.

Observations :

- If the vehicle stops or reduces speed (for example when approaching a stop sign), the gearbox changes down automatically to first gear.
- In sequential mode, it is not necessary to release the accelerator during gear changes.



- The flashing of the warning lamp for the position requested signals that this position is not yet obtained.
 - If the warning lamp is on fixed, the position is confirmed.
 - Display of a dash in the rev counter indicates a malfunction. Urgently contact a CITROËN dealer.
- Lighting of the SERVICE warning lamp accompanied by a message and a sound signal indicates a functioning anomaly. In this case :
- a marked snatching may be felt when selecting **R** for reverse gear,
 - the gearbox is locked on a gear,
 - do not exceed 100 km/h (approx. 60 mph).
- Urgently contact a CITROËN dealer.



ABS - Anti-lock braking system

This system enhances your safety by preventing the wheels from locking under heavy braking or in conditions of poor road adherence.

It enables you to retain control of the steering.

The operating capacity of all the electrical components that are essential to the ABS system is checked by an electrical monitoring system before and during your journey. The ABS warning lamp comes on when you switch on the ignition and should go out after a few seconds.

If the warning lamp does not go out, this means that the ABS has disconnected as a result of a malfunction. Also, if the warning lamp lights up during a journey, it means that the ABS system is inactive. In either case, the normal braking system remains fully effective, as on a non-ABS vehicle. However, to restore the safety associated with the correct operation of the ABS, the vehicle should be examined as soon as possible by a CITROËN dealer.

On slippery surfaces (gravel, snow, ice, etc.), driving carefully is still essential.

Emergency braking assistance system

In an emergency, this system enables you to achieve the optimum braking pressure more quickly, thereby reducing the stopping distance. It deploys according to the speed of your action on the brake pedal, reducing the resistance to that action. To prolong the effect of the emergency braking assistance, simply keep your foot on the brake pedal.

State of wear of brake discs and drums

For all information relating to the checking of the state of wear of brake discs and drums, contact a CITROËN dealer.



The electronic parking brake combines 2 operational modes :

- **AUTOMATIC :**

Automatic application when the engine stops and automatic release on use of the accelerator (automatic operation by default),

- **MANUAL :**

Permanent manual application / release of the parking brake is possible by pulling control **A**.

AUTOMATIC OPERATION

To start the vehicle

The electronic parking brake **releases automatically and progressively** when you press the accelerator :

- with a **manual gearbox** (**first gear** or **reverse gear** engaged), press down fully on the clutch pedal then press on the accelerator pedal and move off.
- with an **automatic gearbox**, accelerate with the selector in position **D**, **M** or **R**.
- with an **electronic gearbox**, accelerate with the selector in position **A**, **M** or **R**.



Full release of the parking brake is confirmed by :

- the extinction of warning lamp **P** on control **A** and on the instrument panel,
- the display of a message « parking brake released » on the multifunction display.



When stationary, with the engine running, do not press the accelerator pedal unnecessarily, as you may release the parking brake.

To immobilise the vehicle

Immobilisation, engine off

With the vehicle stationary, the parking brake **is automatically applied when the engine is switched off**.



The application of the parking brake is confirmed by :

- the lighting of warning lamp **P** on control **A** and on the instrument panel,
- the display of a message « parking brake applied » on the multifunction display (except DT).

Note : an operation sound will confirm to you the application/release of your electronic parking brake.



Before leaving the vehicle, check that warning lamp **P** on the instrument panel is permanently lit.

Never leave a child alone inside the vehicle with the ignition on, as they could release the parking brake.



Immobilisation, engine running

With the engine running and the vehicle stationary, in order to immobilise the vehicle you need to manually apply the parking brake by **pulling** on control **A**.



The application of the parking brake is confirmed by :

- the lighting of warning lamp **P** on control **A** and on the instrument panel,
- the display of a message « parking brake applied » on the multifunction display.

When the driver's door is opened, a beep is heard and a message displayed if the parking brake has not been applied.



Before leaving the vehicle, check that warning lamp P on the instrument panel is permanently lit.

ACTIVATION / DEACTIVATION OF THE AUTOMATIC FUNCTIONS

The automatic application when the engine is switched off and the automatic release when you press the accelerator can be deactivated. Activation / deactivation is performed using the Menu of the instrument panel screen. To do so, select « Personalisation/Configuration / Define the Vehicle parameters / Driving assistance / Automatic handbrake ».



The deactivation of these functions is confirmed by the lighting of this warning lamp on the instrument panel.

With the automatic functions deactivated, the application and release of the parking brake are done manually.

The deactivation of the automatic functions is recommended in particularly cold conditions (ice) and during towing (breakdown, caravan, ...)

MANUAL OPERATION

Manual application / release of the parking brake is always possible.

To start the vehicle

With the ignition on or the engine running, to release the parking brake, press on the brake pedal, **pull then release** control **A**.



The full application of the parking brake is confirmed by :

- the extinction of the warning lamp on control **A** and of warning lamp **P** on the instrument panel,
- the display of a message « parking brake released » on the multifunction display.



Note : If you pull control **A** without pressing the brake pedal, the parking brake will not be released and the « foot on brake » warning lamp will light up on the instrument panel.

To immobilise the vehicle

With the vehicle stationary, to apply the parking brake whether the engine is running or off, **pull** on control **A**.



The application of the parking brake is confirmed by :

- the lighting of the warning lamp on control **A** and of warning lamp **P** on the instrument panel,
- the display of a message « parking brake applied » on the multifunction display.

When the driver's door is opened with the engine running, a beep is heard and a message displayed if the parking brake has not been applied.

MAXIMUM APPLICATION

If necessary, you can utilise **maximum application** of the parking brake. It is obtained by means of a **long pull** on control **A**, until you see the message « parking brake applied » and a beep is heard.

Maximum application is indispensable :

- in the case of a vehicle towing a caravan or a trailer, if the automatic functions are activated but you are applying the parking brake manually,
- when the gradient you are parked on is variable in its effect (e.g. on a ferry, in a lorry, during towing).

Note :

- In the case of towing, a loaded vehicle or parking on a gradient, turn the front wheels towards the pavement and engage a gear when you park.
- After a maximum application, the release time will be longer.

PARTICULAR SITUATIONS

In certain situations (starting the engine ...), the parking brake can automatically alter its force. This is normal operation.

To advance your vehicle a few centimetres without starting the engine, but with the ignition on, press on the brake pedal and release the parking brake **by pulling** then **releasing** control **A**. The full release of the parking brake is confirmed by the extinction of warning lamp **P** (red) on the instrument panel and the display of a message « parking brake released » on the multifunction display.

If the parking brake malfunctions **while applied** or if the battery runs flat, an emergency release is always possible (see paragraph « Emergency unlocking »).

DYNAMIC EMERGENCY BRAKING



In the event of a failure of the vehicle's main braking system or in an exceptional situation (e.g. driver taken ill, under instruction, etc) a continuous pull on control **A** will stop the vehicle.

The electronic stability programme (ESP) provides stability during dynamic emergency braking.

If the dynamic emergency braking malfunctions, one of the following messages will be displayed on the instrument panel screen :

- « Parking brake faulty ».
- « Parking brake control faulty ».



If a failure of the ESP system is signalled by the lighting of this warning lamp, then braking stability is not guaranteed. In this event, stability must be assured by the driver by repeating alternate « pull-release » actions on control **A**.

The dynamic emergency braking must only be used in exceptional circumstances.

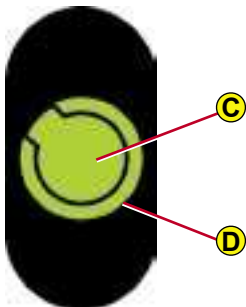
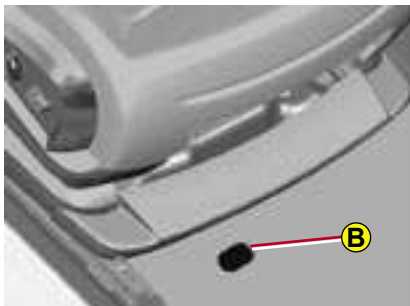

EMERGENCY UNLOCKING

In the event of the electronic parking brake malfunctioning or the battery running flat, an emergency manual device can unlock the parking brake.

1. Immobilise the vehicle, with the engine running, by engaging first gear (manual gearbox), position **P** (automatic gearbox) or **M** or **R** (6-speed electronic gearbox), then switch off the engine.

Note : if it is impossible to immobilise the vehicle, do not action the control and urgently contact a CITROËN dealer.

2. Fetch the vehicle blocks and the unlocking device (braided cable) from the toolbox (see « Changing a wheel », paragraph on « Tools »).
3. Immobilise the vehicle by placing blocks at the front and at the rear of one of the rear wheels.
4. Slide the front left-hand seat back as far as possible.
5. Lift up the floor plug **B** in the carpet under the seat.
6. Pierce the tab **C** on the tube **D** with the unlocking device.
7. Place the unlocking device in the tube **D**.
8. Turn the unlocking **device clockwise**. **For safety reasons**, it is **essential** to continue turning the device as far as it will go or until you hear a knocking noise. The parking brake is released.
9. Remove the unlocking device and store it with the blocks in the toolbox (see « Changing a wheel », paragraph on « Tools »)

Note :

- The operation of the parking brake re-initialises when the ignition is switched off then on again. If the reinitialisation of the parking brake proves impossible, contact a CITROËN dealer.
- The subsequent time required for application may be longer than during normal operation.









For safety reasons, after this manoeuvre it is essential to contact a CITROËN dealer urgently to have the plug replaced.

Following an emergency unlocking, immobilisation of the vehicle is no longer guaranteed once the manual emergency unlocking has been deployed and the manual control does not allow the re-application of your parking brake.





Take no action, either on control A, or stopping starting the engine while the unlocking device is engaged.

Take care not to allow moisture or dust in the proximity of the plug.



	SITUATION	CONSEQUENCES
1	Electronic parking brake fault and display of message « Parking brake faulty » and the following warning lamps :  	If the electronic parking brake fault warning lamp and the service warning lamp light up, position the vehicle in a safe location (on flat ground, with a gear engaged).
2	Display of message « Parking brake faulty » and the following warning lamps :   	<ul style="list-style-type: none"> - The automatic functions are deactivated. - The hill start assist is unavailable. - The electronic parking brake is only available manually.
3	Display of message « Parking brake faulty » and the following warning lamps :  	<ul style="list-style-type: none"> - The manual unlocking of the electronic parking brake is unavailable. - The hill start assist is unavailable. - The automatic functions and manual application are still available.

If any of these instances arises, contact a CITROËN dealer as soon as possible.

	SITUATION	CONSEQUENCES
4	<p>Display of message « Parking brake faulty » and the following warning lamps :</p>  	<ul style="list-style-type: none"> - The automatic functions are deactivated. - The hill start assist is unavailable. <p>To apply the electronic parking brake :</p> <ol style="list-style-type: none"> 1. Immobilise the vehicle and switch off the ignition. 2. Pull the control lever for at least 5 seconds or until maximum application. 3. Switch on the ignition and check that the electronic parking brake warning lamps are on. <p>Note : - Application may take longer than in normal operation. - If warning lamp P flashes or if the warning lamps do not come on when the ignition is switched on, this method does not work. Contact a CITROËN dealer.</p> <p>To release the electronic parking brake :</p> <ol style="list-style-type: none"> 1. Switch on the ignition. 2. Pull the control lever and hold it for approximately 3 seconds.
5	<p>Display of message « Parking brake control faulty – automatic mode activated » and the following warning lamps :</p> 	<ul style="list-style-type: none"> - Only the functions for automatic application on switching off the engine and automatic release on acceleration are available. - Manual application/release of the electronic parking brake and dynamic emergency braking are unavailable.
6	<p>Battery fault</p> 	<ul style="list-style-type: none"> - Lighting of the battery warning lamp makes it essential to stop the vehicle as soon as traffic allows. Stop and immobilise your vehicle. - Apply the electronic parking brake before switching off the engine.

If any of these instances arises, contact a CITROËN dealer as soon as possible.

HILL START ASSIST

To aid starting on a gradient, your vehicle is equipped with a system which keeps it temporarily immobilised for the time (approximately 2 seconds) it takes to move your foot from the brake pedal to the accelerator pedal.

This function is only active when :

- The vehicle is completely stationary, with your foot on the brake pedal.
- In particular conditions on a slope.
- With the driver's door closed.

Note :

The hill start assist function cannot be deactivated.



Display of these warning lamps indicates a malfunctioning of the hill start assist function.



On an ascending slope, with the vehicle stationary, the vehicle is held for a brief moment when you release the brake pedal :

- provided you are in first gear or neutral on a manual gearbox,
- provided you are in **A** or **M** on an electronic gearbox,
- provided you are in **D** or **M** on an automatic gearbox.



On a descending slope, with the vehicle stationary and reverse gear engaged, the vehicle is held for a brief moment when you release the brake pedal.



Warning :

do not exit the vehicle while it is being held in the hill start assist phase.

If you need to exit the vehicle with the engine running, manually apply the parking brake and ensure that the warning lamp P (red) on the instrument panel is permanently on.

PARKING SPACE SENSOR

II

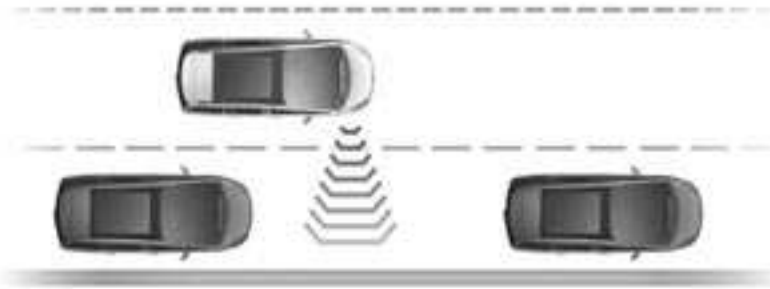

The parking space sensor function assists you in finding a parking space. it measures the size of the space and gives you information on :

- the possibility of fitting into a free space, depending on the dimensions of your vehicle and the distances necessary for your manoeuvring,
- the level of difficulty of the manoeuvre to be performed.

Note : The system does not measure spaces which are clearly much smaller or larger than the size of the vehicle.

You can select the « parking space sensor » function by pressing button **A**. The fixed lighting of the warning lamp indicates that the function is selected.



Parking space sensor warning lamp

This warning lamp can have three different statuses :

- **off** : the function is not selected.
- **on fixed** : the function is selected but the conditions for measuring are not yet met (direction indicator not operating, speed too high) or the measuring phase is terminated.
- **flashing** : the measuring is in progress or the message is being displayed.

PARKING SPACE SENSOR

Operation :

You have identified a parking space :

1. Press button **A** to select the function.
2. Activate the direction indicator on the side where the space is to be measured.
3. During the measuring, go forward the length of the space, at a speed less than 20 km/h (approx. 12 mph), to prepare for your manoeuvre.

The system then measures the size of the space.

4. The system informs you of the level of difficulty of the manoeuvre via a message on the multifunction screen accompanied by a gong.
5. Depending on the message issued by the system, you may or may not be able to perform the manoeuvre.

The function displays the following types of message :

Parking possible

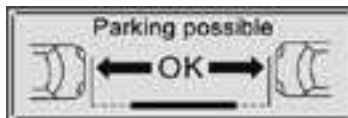

Parking difficult

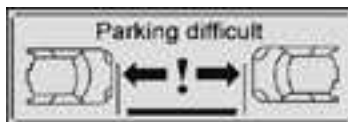

Parking not advised



Note : The function deselects itself automatically :

- when you engage reverse gear,
- when you switch off the ignition,
- if measuring is not requested,
- within five minutes of selection of the function,
- if the vehicle speed exceeds the threshold of 70 km/h (approx. 45 mph) for one minute.

Warning : if the lateral distance between your vehicle and the parking space is too large, the system may not be able to measure the space.

Notes :

- The function remains available after each measurement and thus can measure more than one space during your search.
- In bad weather conditions or in winter, make sure that the sensors are not covered by dirt, or by ice or snow.
- The parking space sensor function deactivates the front parking assistance during the space measuring phase when you are in forward gear.

If there is a malfunction, have the system checked by a CITROËN dealer.

Electronic stability programme (ESP) and traction control (ASR)

These systems are closely connected to the ABS and additional to it. In the event of a loss of control of the vehicle by the driver, the **ESP system** acts automatically on one or more brakes and also on the engine to bring the vehicle back on trajectory. The **ASR system** optimises traction and prevents wheel spin by acting on the brakes of the driving wheels, as well as on the engine. It also improves steering stability during acceleration.

Operation :

When either the ESP or ASR system is in operation, the **ESP/ASR** warning lamp flashes.

Deactivation

In exceptional conditions (vehicle stuck in snow, soft ground, etc.) it may prove useful to deactivate the ESP/ASR system to allow the wheels to spin and thus regain traction.

- Press on control **A**, the **ESP/ASR** warning lamp and the control light up. **The ESP/ASR systems are no longer active.**

The ESP/ASR systems will activate again :

- **Automatically** after the ignition has been switched off.
- **Automatically** above a speed of 50 km/h (30 mph).
- **Manually** with a new press on control **A**.

Operational anomaly

If the systems malfunction, the **ESP/ASR** warning lamp comes on, accompanied by a sound signal and a message on the multifunction display. Contact a CITROËN dealer to have the system checked.



SAFETY RECOMMENDATIONS

The ESP system offers increased driving safety but is not in place to encourage the driver to take additional risks or to drive at excessive speeds.

The functioning of this system is subject to compliance with the manufacturer's recommendations on wheels (tyres and rims), brake parts and electronic components, as well as with CITROËN's assembly and repair procedures.

After any collision, have this system checked by a CITROËN dealer.

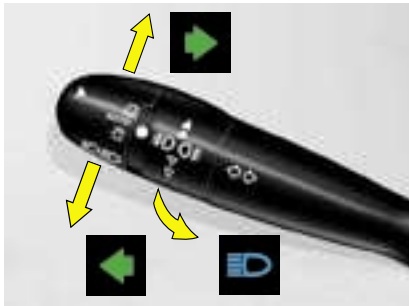

Direction indicators

Left, downwards.

Right, upwards.

For a change of direction, operate the control stalk to go beyond the “tight spot”. It will revert automatically to its initial position with the return of the steering wheel.

Headlamp flash

Pull the control stalk towards you.

The headlamp flash is possible even with the ignition switched off.

Horn

Press at the lower part of the fixed centred controls steering wheel.



Emergency activation of the hazard warning lamps

A heavy deceleration of the vehicle will cause the hazard lamps to activate automatically.

They will cease automatically on reacceleration of the vehicle or manually if you press on the hazard lamps button on the dashboard.

Distress signal

The distress signal operates all the direction indicators simultaneously.

Only make use of this in a situation of danger, for an emergency stop or if you find yourself driving in exceptional weather conditions.

The distress signal will operate even with the ignition switched off.

Sound signal for vehicle lamps left on

With the ignition switched off, the signal will activate when the driver's door is opened, to indicate that lamps have been left on.

It will cease when the door is closed, the lamps switched off, or the ignition switched on again.

This signal is inactive if the automatic lighting of headlamps and / or the guide-me-home lighting are activated.

Parking lights

These are for signalling the presence of your vehicle when it is parked.

They can be activated by operating the direction indicator immediately after switching off the ignition, to light the front and rear sidelamps on the side selected.

A sound signal and the temporary lighting of the direction indicator confirm the activation of the function.

Driving with the hazard lamps activated renders the direction indicators inoperational.



EXTERIOR SIDE LIGHTERS

These illuminate :

- the zones facing the driver's and passenger's doors,
- the zones forward of the door mirrors and rearward of the front doors.

Illumination / extinction

The side lighters come on :

- when you unlock the vehicle or press on the lighting button on the remote control.
- when you remove the key from the ignition,
- when you open a door,
- when you use the remote control to locate your vehicle.

They are timed to go out automatically.

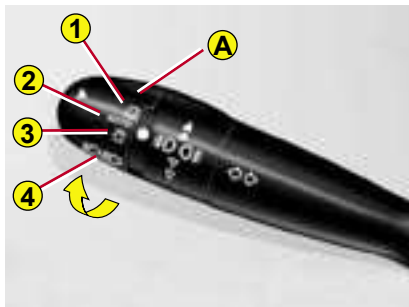

LIGHTING CONTROL

- 1 Stop
- 2 Automatic lighting
- 3 Sidelamps
- 4 Dipped beams / Main beams



All lamps off

Turn the ring **A** forwards.



Automatic lighting of headlamps

The sidelamps and dipped beams come on automatically when the ambient light is insufficient or if the windscreen wipers are in continuous operation.

They go out as soon as the light is again sufficient or approx. 5 minutes after the windscreen wipers have ceased.

To activate this function, place the control **A** on position **2**.

Do not cover the sunlight sensor which is located behind the interior rear view mirror and visible from outside the windscreen.

Turn the ring **A** forwards.



Sidelamps on

Turn the ring **A** forwards.



Dipped beams / main beams on

Pull the control stalk fully towards you to swap between dipped beams and main beams.

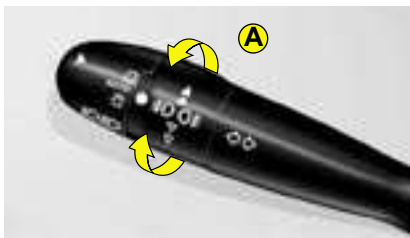

GUIDE-ME-HOME LIGHTING

With the ignition off, this function temporarily switches on your headlamps to give you exterior lighting when you are leaving your vehicle.

This function is activated :

- Manually by pulling the control stalk towards you, after switching off the ignition.
- Automatically in the following conditions :
 - automatic headlamp lighting is activated,
 - and guide-me-home lighting is activated.

See chapter « Multifunction display ».

Note : It is possible to modify the timing for the guide-me-home lighting (around 60, 30 or 15 seconds) in the «Personalisation-Configuration» menu.

For multifunction screen **A**, the timing is fixed.

FRONT AND REAR FOG LAMPS (Ring A)



These operate in conjunction with the sidelamps, the dipped beams or the main beams.

For a vehicle equipped with rear foglamps :

- 1st turn forwards : lighting of rear foglamps.
- 1st turn rearwards: extinction of rear foglamps.

For a vehicle equipped with front and rear foglamps:

- 1st turn forwards: lighting of front foglamps.
- 2nd turn forwards: lighting of rear foglamps.
- 1st turn rearwards: extinction of rear foglamps.
- 2nd turn rearwards: extinction of front foglamps.

Note : Foglamps should be used only in conditions of fog or snowfall.



Headlamps adjustment

Depending on the vehicle load, it is recommended that you correct the height of your headlamp beams.

On the dashboard beside the driver :

- 0** Unladen
- 1** Partial load
- 2** Medium load
- 3** Full load.

Note : Vehicles equipped with Xenon dual-function directional headlamps have an automatic adjustment of headlamps depending on load.

In foggy conditions, if the ambient brightness is not such as to activate the automatic lighting, it is up to you to switch on your dipped beams manually, along with your foglamps as necessary.

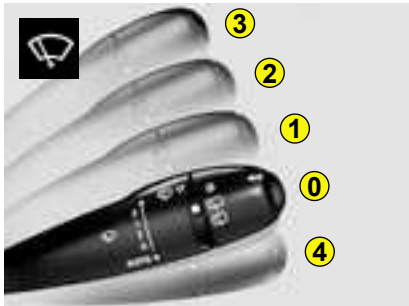

Windscreen wipe

- 3 Rapid wipe.
- 2 Normal wipe.
- 1 Intermittent wipe.
- 0 Stop.
- 4 Automatic wipe by pressing downwards, and single wipe.

Note : To deactivate automatic wipe :
- go to position **1**, then return to position **0**.

Position 1 : The wipe interval will adjust automatically as a function of the speed of the vehicle.

Note : In position **2** or **3** : when the vehicle is stationary the wipe interval will reduce automatically.

For safety, the wiper system is deactivated approx. one minute after you switch off the ignition.

When you switch on the ignition, to reactivate the function :

- return to the **Stop position**,
- go to the **position desired**.

Vehicle equipped with a rain sensor

Position 4 by pressing downwards : The wipe interval will adjust automatically as a function of the intensity of the rain.

Note : A press downwards produces a single wipe without deactivating automatic wipe.

IMPORTANT :

Do not cover the rain sensor, which is located behind the interior rear view mirror and visible from outside the windscreen.

If washing the vehicle, switch off the ignition or deactivate automatic wipe.

Changing the wiper blades

For replacement, the wipers should be stopped **in the maintenance position**.

Switch off the ignition, then within a minute action the wiper control stalk. The wipers will position themselves in the middle of the windscreen.

After replacement, the wipers will resume their normal position when you switch on the ignition and action the wiper stalk.

**For safety, the wiper system is deactivated approx. one minute after you switch off the ignition.
If the windscreen is frozen when you are starting a journey, make sure that you de-ice it before using the front and rear wipers.**

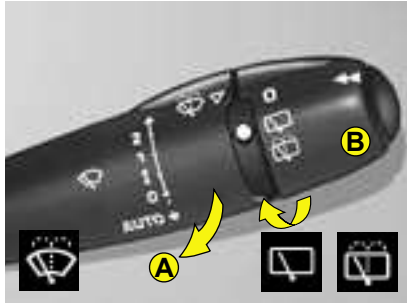

A - Headlamp wash

Provided the dipped beams are on, pull the control stalk towards you : screen wash will then be accompanied by a timed sweep of the wipers as well as by a headlamp wash.

B - Rear screen wipe



Stop.



Intermittent rear screen wipe.



Timed rear screen wash and wipe.

Rear screen wipe will deploy automatically, provided the windscreen wipers are operating, when you engage reverse gear.

Activation / deactivation of this function is possible via the « Personalisation - Configuration » menu in the « Main menu ».

Note : Deactivation may be essential if you install a bicycle-carrier on the tailgate.

Check that the front and rear wipers are able to operate freely if for example you are installing a bicycle-carrier, or in freezing conditions. Remove any accumulation of snow from the base of the windscreen.

INTERIOR REAR VIEW MIRROR

II



The lever on the bottom edge of the interior rear view mirror enables it to be placed in two positions :

Day position : the lever is not visible.

Night position (anti-dazzle) : the lever is visible.



Automatic photochromic interior rear view mirror

It modifies its role automatically and progressively between day use and night use.

In order to prevent dazzle, the glass automatically darkens as a function of the intensity of light coming from behind. It lightens as this diminishes, thus giving you optimum visibility.

Operation

With the ignition on, press on control 1.

- Warning lamp 2 on : automatic mode.
- Warning lamp 2 off : end of automatic mode. The glass remains in its lightest definition.

Note : For optimum visibility, the glass lightens automatically when you engage reverse gear.

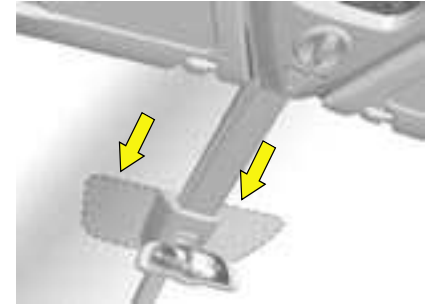

Permit reader

The athermic windscreen comprises a zone situated on either side of the base of the child mirror, to enable access permits to be read (e.g. motorway toll permit).

Child mirror

A child monitoring mirror is installed above the interior rear view mirror. This allows you to monitor the vehicle's rear passengers, or it can facilitate conversation between the front and rear passengers without the need to move the rear view mirror. It can be folded away to eliminate dazzle.



REAR VIEW MIRRORS ADJUSTMENT

This operates with the ignition switched on.

From the driver's seat position, select the rear view mirror by moving control **1** to the left or right, then adjust the rear view mirror in the four directions by acting on control **2**.

Demisting-deicing of the rear view mirrors is coupled with that for the rear screen.

REAR VIEW MIRRORS FOLDBACK

When the vehicle is parked, the rear view mirrors can be folded back either manually or electrically.

Electrically

From the central position, a press to the rear on control **1** folds the rear view mirrors back.

The opposite movement is obtained by pressing again on the rear of the control.

Electrically and automatically

The rear view mirrors also fold back automatically when you lock the doors.

The rear view mirrors redeploy when you unlock the vehicle, unless the foldback was performed manually. In this case, you have to press on the rear of the control to deploy them.

Note : The automatic foldback of the rear view mirrors can be deactivated. Contact a CITROËN dealer.

Adjusting the indexed position of the driver's and passenger's rear view mirrors

With the engine running :

- Select the rear view mirror using control **1**.
- Engage reverse gear, the glass of the rear view mirror positions itself automatically to give a better sight of the pavement.
- If necessary, adjust your rear view mirror to your preference by means of the electrical control **2**. This position is then memorised.

Deactivation of the rear view mirror indexing function

To deactivate the function, move control **1** to the central position.

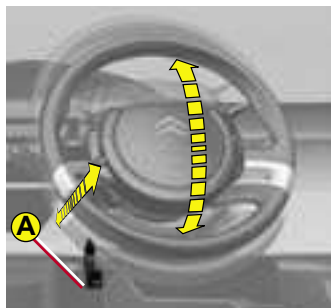

Adjusting the steering wheel

The steering wheel can be adjusted for height and reach.

WITH THE VEHICLE STATIONARY, first adjust your seat to the most suitable position, then adjust the position of the steering wheel.

See « Driving position ».

Unlock the steering wheel by pulling the control **A** towards you.

Adjust the position of the steering wheel then lock it by pushing the control firmly back into its initial location.

Note : If you press firmly on your steering wheel after locking, a small click may be heard.

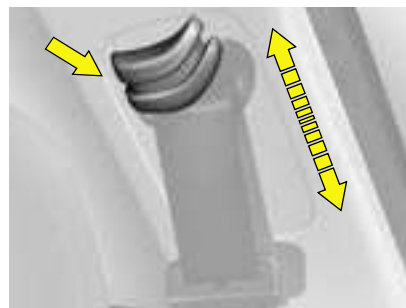

Adjusting the seat belt height

The correct positioning of the seat belt reel is around mid-shoulder level (see : USER PRECAUTIONS).

To adjust the belt, pinch the control and slide it in the direction required.



For safety, these manoeuvres should not be performed while the vehicle is in motion.

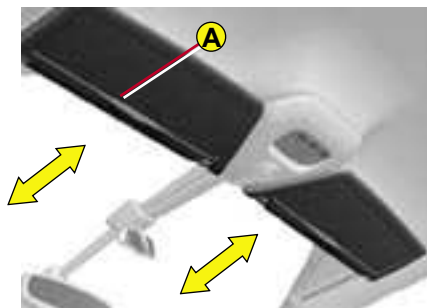

SLIDING SUN VISORS

Sliding blinds

Sliding blinds are provided for your protection against bright sunlight. They can be adjusted manually.

- Slide the blind on the visor to the desired position by pushing the area **A**.

Visor struts

The blinds are extended on the sun visor struts.

Fold the visor downwards, to protect against dazzle to the face.

If dazzle is coming from the side windows, detach the visor from its housing above the centre of the windscreen and pivot it to the side.

Do not attach or suspend heavy objects on the slide rail of the sun blind, which also incorporates the interior rear view mirror.

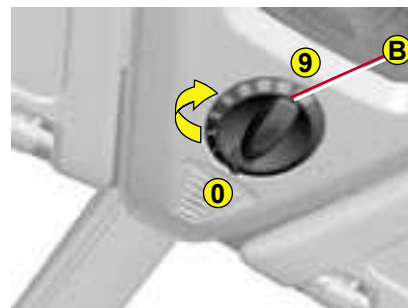

PANORAMIC GLASS ROOF BLIND

Opening the roof blind (positions 1 to 9)

- Rotate the control **B** to slide the roof blind to the position desired.

Closing the roof blind (position 0)

- Rotate the control **B** to **position 0** to close the roof blind.

The blind has an anti-pinch device.

Note :

- A long press on the locking button on the remote control will close the blind (practical when for example you leave your vehicle on a sunlit carpark).
- On returning to your vehicle, a short press on the button **B** repositions the blind to the last position selected.
- Following a fault or after a battery disconnection during the movement of the blind or after it has stopped, you have to re-initialise the anti-pinch function. Place the blind in the closed position and press for around 2 seconds on button **B**.

CRUISE CONTROL

II



This driving assistance device enables you to drive at a constant speed of your choice, without the need to action the accelerator. It is active over speeds of around 40 km/h (approx. 25 mph).

The cruise control commands are located on the steering wheel.

Note : The information relating to the cruise control is displayed in zone **A** of the instrument panel.

Selection of the function

Rotate the control **1** to the «REG» position.

Selection of a cruise speed

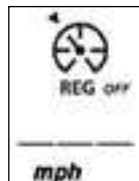

On selection of the function via control **1**, **no cruise speed has yet been memorised.**

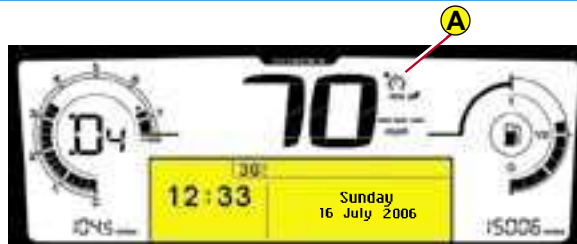

Bi-tone instrument panel

Once the desired speed has been reached via action on the accelerator, press button **2** or button **4**. The cruise speed is then memorised. It is displayed in zone **A** of the instrument panel.

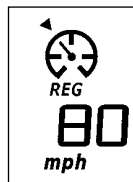

You can then release the accelerator pedal. The vehicle will automatically keep to the speed chosen.

Note : The speed of your vehicle may vary slightly in relation to that memorised.

If during the operation of cruise control, the system is unable to keep within the memorised speed (for example on a steep descent), then the speed flashes. Adapt your speed as necessary.

Adjustment of the memorised speed while cruise control is in operation

You can adjust the memorised speed, displayed in zone **A**, by pressing on :

- button **4** to increase the speed,
- button **2** to decrease the speed.

Note : successive presses will modify the cruise speed in steps of 1 km/h and a sustained press in steps of 5 km/h (3 mph).

Temporary override of the cruise speed

During the operation of cruise control, it is always possible to action the accelerator to go faster than the cruise speed (for example to overtake another vehicle). The speed displayed in zone **A** flashes.

You have only to release the accelerator pedal to return to the cruise speed.

CRUISE CONTROL

Observation : If during the operation of cruise control, the system is unable to keep within the memorised speed (for example on a steep descent), then the speed flashes. Adapt your speed as necessary.

Disengaging of cruise control while retaining the memorised speed

- Either by pressing on the brake pedal or on the clutch pedal.
- Or by pressing button **3**.
- Or if either the ESP or the ASR system is active.

Note : cruise control is not active if the gear lever is in neutral.

These actions cause the information «OFF» to appear in zone **A** of the instrument panel.

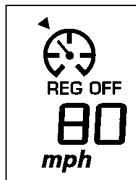

These manoeuvres do not cancel the cruise speed which remains displayed in the instrument panel.

Re-engaging cruise control

- by recall of the memorised speed :

After a disengagement, press on button **3**. Your vehicle automatically returns to the memorised cruise speed which is displayed in zone **A**.

If the memorised cruise speed is higher than the current speed, the vehicle will accelerate to reach the former.

- by selection of the current speed :

Press on button **2** or **4** once the desired speed has been reached. The information «OFF» will then disappear from zone **A**.



Stopping the function

- by an action on the control on position «REG» to position **0**.
- by the engine stopping.

The cruise speed previously chosen is no longer memorised.

If there is a malfunction, a message will display accompanied by a sound signal and lighting of the SERVICE warning lamp.

Contact a CITROËN dealer.



Cruise control should only be used when the driving conditions allow you to drive at a constant speed.

Do not use it in heavy traffic, or on dangerous or slippery roads.

The driver must remain attentive and in full control of his vehicle. You are recommended to keep your feet within range of the pedals.

SPEED LIMITER

II



This driving assistance device enables you to choose a maximum speed that you wish not to exceed. This has to be higher than 30 km/h (around 20 mph).

The speed limiter controls are located on the steering wheel.

Note : The information relating to the speed limiter is displayed in zone A of the instrument panel.

Selection of the function

Rotate the control 1 to the «LIM» position.

On selection of the function, the previous memorised speed and the information «OFF» are displayed :

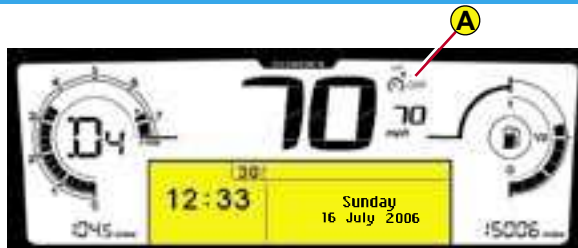
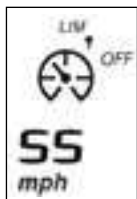

Bi-tone instrument panel

Adjustment of the maximum speed

With the engine running, you can adjust the memorised maximum speed, by means of short or long presses on :

- button 4 to increase the memorised maximum speed,
- button 2 to decrease the memorised maximum speed.

Note : successive presses will modify the maximum speed in steps of 1 km/h and a sustained press in steps of 5 km/h (3 mph).

Activation of the maximum speed

When the desired maximum speed is displayed, press button 3 so that the limitation is activated.

The information «OFF» then disappears from zone A.

While the function is active, pressing the accelerator pedal will not enable the programmed speed to be exceeded, except if you press the pedal hard down to beyond the end-of-travel switch (see « Temporary override of the maximum speed »).

Note : The speed of your vehicle may vary slightly in relation to that memorised.

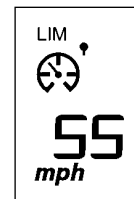

SPEED LIMITER

Disengagement of the maximum speed

Press on button 3.

This action causes the information «OFF» to appear on the instrument panel screen.

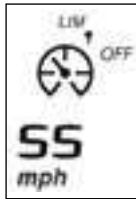

This action does not cancel the memorised maximum speed which remains displayed in zone A of the instrument panel.

Temporary override of the maximum speed

The accelerator pedal is equipped with an end-of-travel switch. If you action this switch by pressing the pedal hard down, you can exceed the memorised maximum speed at any time.

During the time the speed is being exceeded, the displayed speed flashes.

You have only to release the accelerator pedal to return below the maximum speed and render the function active again.

Observation : If during the operation of the speed limiter, the system is unable to keep within the maximum speed (for example on a steep descent or under heavy acceleration) then the speed flashes. Adapt your speed as necessary.

The function will re-engage when your speed returns below the desired maximum speed.



Stopping the function

- by an action on the control on position «LIM» to position 0.
- by the engine stopping.

The speed previously chosen is still memorised.

If there is a malfunction, a message will display accompanied by a sound signal and lighting of the SERVICE warning lamp.

Contact a CITROËN dealer.



Use of floor mats that are not approved by CITROËN may hinder access to the accelerator pedal and thus interfere with the functioning of the speed limiter.

Complementary to the catalytic converter, this filter makes an active contribution to the preservation of air quality by the retaining of the unburnt pollutant particles. Black exhaust fumes are thus no longer emitted.

Clogging of the particle filter

If there is risk of clogging, a message appears on the multifunction display, accompanied by a sound signal and lighting of the SERVICE warning lamp.

This alert tells you that the particle filter is starting to fill up (in conditions of urban driving of exceptionally long duration: low speeds, traffic jams etc.)

To regenerate the filter, it is advised to drive as soon as possible, when traffic conditions permit, at a speed of 60 km/h (around 40 mph) or more for at least five minutes (until the alert message disappears).

If this alert persists, consult a CITROËN dealer.

Observation : After prolonged idling or driving at very low speeds, you may occasionally notice water vapour being emitted from the exhaust when accelerating. This is of no consequence to the running of the vehicle or to the environment.

Diesel fuel additive level

If the additive level becomes too low, a message appears on the multifunction display, accompanied by a sound signal and lighting of the SERVICE warning lamp. It is necessary to have the additive level topped up. Urgently consult a CITROËN dealer.

LANE DEPARTURE WARNING SYSTEM



This driving assistance device alerts you if you are wandering from your lane (continuous or dotted line marking on the road surface).

It is designed especially for use on motorways and dual carriageways, operating only at speeds above 80 km/h (approx. 50 mph).

Activation / Deactivation

A press on control **A** activates the function, the warning lamp on the control lights up.

A second press on control **A** deactivates the function, the warning lamp on the control goes out.

Whenever you start the engine, the mode (activated/deactivated), selected when you last switched off the engine, is retained.

Operation

Provided you are travelling at over 80 km/h (approx. 50 mph), if you cross a lane marking, you are alerted by a vibration within the cushion of your seat :

- oriented to the right for crossing a lane marking to the right,
- oriented to the left for crossing a lane marking to the left.

The system does not alert you while your direction indicator is operating, nor for about 20 seconds after your direction indicator has stopped.

Note : In the event of an electronic malfunction, a message is displayed, the **SERVICE** warning lamp comes on and a sound signal is heard. Contact a CITROËN dealer.

Observations : This device is designed to identify traffic lane markings.

In certain specific instances, it may trigger an unwanted alert, for example when you cross a direction arrow or some other random marking.

The effectiveness of the system may be temporarily affected by conditions external to the vehicle :

- Detection of lanes made difficult by:
 - Markings that are worn or erased.
 - Insufficient contrast with the surface of the road.
- Masking of the sensors due to:
 - Driving in snow or heavy rain.
 - Driving on roads covered with mud or surface water.

If the system is ineffective for a prolonged period, contact a CITROËN dealer.

The driver must still remain attentive and in complete control of the vehicle.

XENON DUAL-FUNCTION DIRECTIONAL HEADLAMPS

II

This function is associated with Xenon dual-function directional headlamps.

Whether on dipped beam or main beam, your headlamps follow the direction of the road ahead.

Lighting quality when driving round bends is considerably improved.

On vehicles equipped with day-time-running lamps (according to country), the function is activated only if the lighting control is on main beam / dipped beam or **AUTO** (automatic lighting of headlamps). If the control is in position **0**, the function is not active.



Function active



Function inactive

Activation / Deactivation

The function can be activated / deactivated in the « Main menu ». See « Multifunction displays ».

When you start the engine, you retain the mode (activated or deactivated) that was selected when you last stopped the engine.

By default, this function is in activated mode.

Note : At zero or very low speed, or in reverse gear, this function is inactive.

If there is a malfunction, a message informs you of this and the « Dipped beams » warning lamp flashes.

Have the system checked by a CITROËN dealer.

You are recommended to have both Xenon dual-function directional headlamps changed if there has been a malfunction in either of them.



**Multifunction
screen DT**



**Multifunction
screen C**

Proximity sensors are located in the **front and rear bumpers** of your vehicle.

Functioning

- **When you engage reverse gear**, a sound signal informs you that the system is active. The silhouette of your vehicle is displayed on the multifunction screen C or DT. Obstacles situated at the rear or in front of the vehicle will be detected.
- **When you are moving forward**, provided this is at a speed less than 10 km/h (approx. 6 mph), either in neutral or in gear, the shape of your vehicle is displayed on the screen as soon as an obstacle is detected in front of the vehicle. Obstacles located in front of the vehicle will be detected.
- **In forward gear or in reverse gear**, as the vehicle approaches the obstacle, the sound signal becomes more and more rapid and the bars are seen to move ever nearer to the vehicle.
- **Whether in forward gear or in reverse gear**, when the obstacle is close, the sound signal becomes continuous and the **WARNING** panel appears on the multifunction display.

Note : the sound signal is emitted by the loudspeakers that are nearest to the obstacle.



When you engage reverse gear, a short sound signal followed by a different sound signal accompanied by a message and the lighting of the SERVICE warning lamp, indicates that there is a malfunction. Contact a CITROËN dealer.



Activation / Deactivation

You can activate/deactivate the parking assistance by pressing control **A**. If the parking assistance is inactive, the warning lamp is on.

Activation or deactivation of the parking assistance is memorised when you stop the vehicle.

Notes :

- The rear parking assistance is deactivated automatically if a trailer is attached to the vehicle. The fitting of the towbar should be carried out by a CITROËN dealer.
- The proximity sensors will not be able to detect obstacles that are situated immediately below or above the bumpers.
- A thin object such as a spike, or a bollard or other similar object, will be detected only at the start of the manoeuvre, not when the vehicle has arrived up close.
- In bad weather or in winter, make sure that the sensors are not covered by dirt, or by ice or snow.



Electrical control

From the driver's seat position, the controls situated on the door enable the vehicle's electric windows to be actioned.

Note : The windows can also be operated for a short time after the ignition has been switched off (including after the front doors have been opened).

Sequential control

An action to the first notch on the control starts a window movement which stops when the control is released. A press for about one second on the control will close or open the window fully, a further press will stop the movement.

Anti-pinch

An anti-pinch device will stop the glass from rising. If it meets an obstacle, it goes back down.

After a battery disconnection or following a malfunction, you have to re-initialise the anti-pinch function for each window :

- Use the control to open the window fully, then attempt to close it. It will rise only a few centimetres.
- Pull again on the control until the window closes fully. Once the window is closed, sustain the press on the control for one second.

Warning : During this operation, the anti-pinch protection is inoperative.

Child safety



This is for deactivating operation of the electric windows and opening of the rear doors from the rear seat positions.

It is activated by a press on the control **A** located on the window control panel or by an action on the locks of the rear doors.

The warning lamp in the instrument panel comes on temporarily.

Each time you switch on the ignition, the warning lamp lights up for a short time. It is still possible to open the doors from the outside and to operate the rear windows from the front seat positions.

PAY ATTENTION TO WHERE CHILDREN ARE WHEN OPERATING THE ELECTRIC WINDOWS.

- Always remove the key from the ignition when leaving the vehicle, even for a short time.
- When the driver is actioning the controls for the passenger windows, he must make sure that no-one is obstructing the windows from closing properly.
- The driver should ensure that the passengers use the windows correctly.
- If any person should be at risk of becoming trapped by the operation of the windows, you must reverse the movement of the glass. For that, reverse the position of the control concerned.

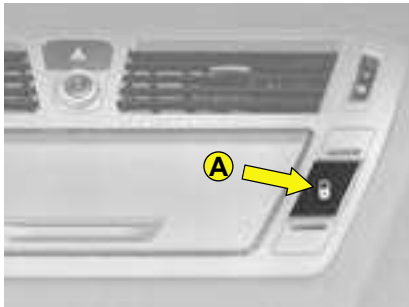

Locking from the inside

A press on the control **A** operates the electric central locking and unlocking, provided the doors and tailgate are closed.

The doors can still be opened from the inside.

If one of the doors is open or not properly closed, the central locking does not operate.

The warning lamp on the control **A** signals 3 statuses :

- It flashes when the doors are locked, with the vehicle stationary and the engine turned off.
- It lights up when the doors are locked, or when the ignition is switched on.
- It goes out if the doors are not locked.

Note : the control **A** is inactive when the vehicle has been locked by means of the remote control or the key

Door selectivity

If you have selected « plip action : driver's door » in the multifunction screen menu :

- a press on the remote control opens the driver's door,
- a second press opens all the doors.

Anti-intrusion security

On starting the vehicle, the system automatically locks the doors when you have reached a speed of around 10 km/h (6 mph).

Note : Whenever a door is opened, the door will lock again automatically when the vehicle reaches a speed of around 10 km/h (6 mph).

Activation / Deactivation of the function

After switching on the ignition, give a long press on the central unlocking control until you see a message displayed and a sound signal is emitted.



If you decide to drive with the doors locked, be aware that this will make access more difficult for the emergency services in the event of an accident.

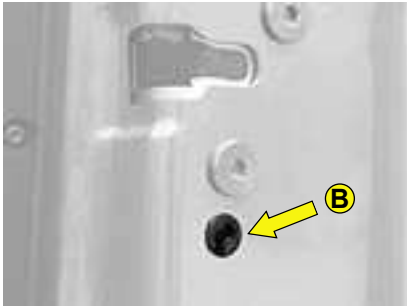

Manual control (emergency mode)

Should there be an electrical failure it is possible to lock the vehicle's doors by actioning the control **B** on each door.

With the door open, insert for example the end of the ignition key into the aperture and turn it.

Close the door.

After a repair, normal functioning resumes by means of the unlocking control **A**, the remote control or the key used in the driver's door.

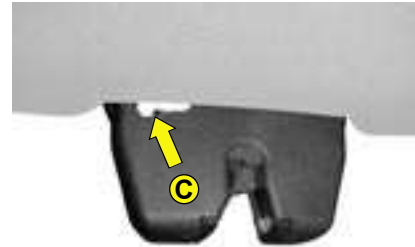

Emergency unlocking of the boot

Should there be a problem with the boot lock, or a battery failure :

- From the interior of the bootspace, face the rear of the vehicle.
- Insert the point of a screwdriver into the aperture **C** of the lock.
- Push the white component inside the lock to the left, to unlock the boot.

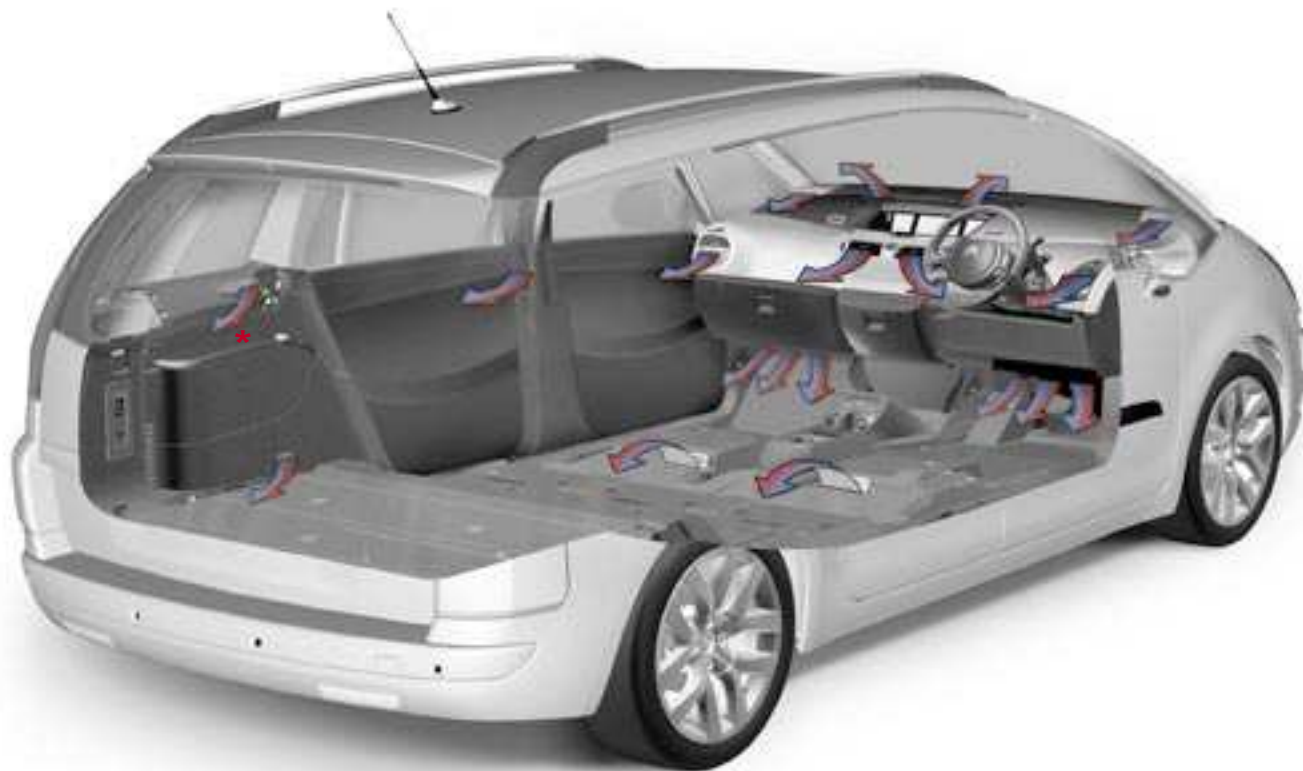

Air inlet

Check that the exterior grille for the air inlet, at the bottom of the windscreen, is clean and free of dead leaves, snow, etc.

Air vents

The air vents to the face have grilles and thumbwheels so that you can adjust the air flow and direction (up-down, right-left).

Air circulation

Air vents on the floor underneath the front seats provide enhanced heating for the rear seat positions : take care not to obstruct them.

Dust filter / odour filter (active carbon)

There is a filter for excluding odours and dust.

This filter has to be changed in accordance with the vehicle maintenance schedule (see the Maintenance Guide).

Air conditioning

To ensure that your system operates correctly, it is recommended to have it checked regularly.

Water arising from condensation in the air conditioning drains away through a hole provided for this purpose. A pool of water may thus form under the vehicle when stationary.

To keep the air conditioning compressor well sealed, it is essential to operate the air conditioning at least once in every month.

To be effective, the air conditioning should only be used with the windows closed.

If after a lengthy stop in bright sunlight the interior temperature is excessive, air the passenger compartment by opening the windows for a few moments, then close them again.

The air conditioning operates by using power from the engine. This results in a slight increase in fuel consumption.



Sensors

The automatic regulation of the air conditioning inside the cabin uses a number of sensors that relieve you of the need to make adjustments outside the displayed temperature.

Be careful not to obstruct the sunlight sensor located on the dashboard.

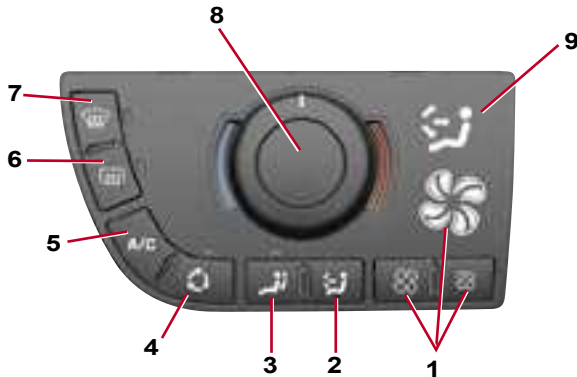

A. DRIVER'S CONTROL PANEL

1 - Adjustment of the air blower speed

The air blower adjustment only operates when the engine is running.

To adjust the air flow, press on button :



to increase the flow of air



to decrease the flow of air

The level of air flow is shown by the progressive lighting of the warning lamps depicting the ventilator blades.

By decreasing the flow to zero, you deactivate the air conditioning system (OFF).

Note : to achieve an agreeable level of comfort in the passenger compartment, you should not leave this control too long in the OFF position.

2 - Adjustment of the air distribution

- Press on button **2** to make the display scroll through the different types of air distribution.



The air distribution chosen is shown by the lighting of the corresponding warning lamps at **9**.

3 - Mode of adjustment of temperature for the passenger

- Press on button **3** to have independent passenger control of cabin air temperature. The warning lamp goes out.

Note : While the passenger is adjusting temperature, the warning lamp lights up.

4 - Air recirculation

This control is for isolating disagreeable odours or fumes coming from outside.

- Press on button **4**, to exclude entry of outside air. The warning lamp lights up.

This should be cancelled as soon as possible to permit renewal of cabin air and to prevent misting.

- Press again on button **4**, to deactivate air recirculation.

5 - Air conditioning

The air conditioning can only operate when the engine is running. The air blower control (adjusting the flow of air) has to be activated in order for air conditioning to be obtained.

- Press on button **5**. The warning lamp lights up.

To be effective, the air conditioning should be operated **only** with the windows closed.

Observation : If your vehicle is not equipped with air conditioning, you will have the same control panel but without the **A/C** button.

6 - Deicing / demisting of the rear screen

This operates only if the engine is running.

- Press on button **6** to activate/deactivate the electric deicing/demisting of the rear screen and the exterior rear view mirrors. The warning lamp lights up.

The deicing/demisting switches off automatically to prevent excessive consumption of power.

7 - Rapid deicing / demisting of front and rear windows and rear view mirrors

- Press on button **7**. The warning lamp lights up.

This function simultaneously activates :

- front deicing/demisting,
- optimum flow of air,
- recirculation prohibition,
- deicing/demisting of rear view mirrors and heated rear screen,
- air conditioning if necessary.

To stop the function, press again on button **7**.

8 - Adjustment of the air blower temperature

This control is for adjusting the temperature of the air in the passenger compartment. It can be used in cold weather as well as in hot weather, provided the air conditioning is active.

Note : The adjustment of the temperature is continuous and progressive starting from one side.

B. PASSENGER'S CONTROL PANEL



Adjustment of temperature











- Press on button **1** to take over control of the temperature. The warning lamp on button **1** lights up.
- Rotate button **1** to adjust your temperature.

Note : The adjustment of the temperature is continuous and progressive starting from one side.

VENTILATION - HEATING - AIR CONDITIONING

- Heating /Manual air conditioning

To make the best use of the system, we recommend :

Action To have :					A/C	
Cold	-	 or 	Max. cold to start with, then personal adjustments	Max. to start with, then personal adjustments	ON	ON to start with, then OFF
Hot	-	 or 	Max. hot to start with, then personal adjustments	Max. to start with, then personal adjustments	-	ON to start with, then OFF
Demisting - deicing		-	Max. hot	-	-	OFF

- Automatic air conditioning

With automatic air conditioning, you are recommended to choose AUTO operation.

AUTOMATIC AIR CONDITIONING

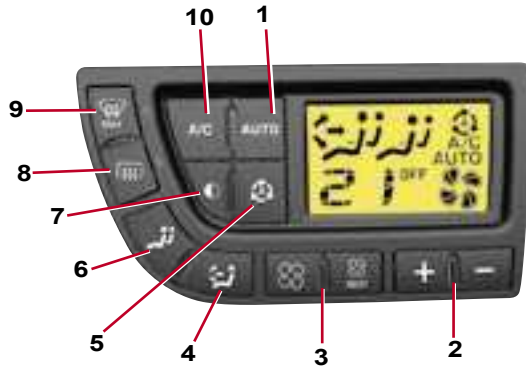

A. DRIVER'S CONTROL PANEL

1 - Automatic comfort regulation



A press on this button, confirmed by the display of the **A/C** warning lamp and of **AUTO** on the screen, provides automatic control, at the temperature selected, of all the following 5 functions :

- air flow,
- cabin temperature, on left hand side and right hand side,
- air distribution,
- air conditioning,
- automatic air recirculation.

For this facility to operate, it is recommended to keep all the air vents open.

Using the **AUTO** mode will prevent misting inside the vehicle in cold or humid weather.

Note : When starting from cold, in order to avoid a rush of cold air, the blower attains its optimum level progressively.

Manual resumption of one or more functions

It is possible to adjust each of the functions **4**, **6** and **10** manually. The display of the «**AUTO**» function will then go off.

Resumption by the driver of the adjustment of cabin temperatures (for the front and rear passengers)

- A long press on this button will realign the temperatures for all passengers with the preferences of the driver.

2 - Adjustment of temperature

The system can regulate temperature on an independent basis for the left hand side and right hand side as well as for the rear of the passenger compartment. Front and rear passengers can thus adjust their own temperatures.

To display the desired temperature, press button :

- - to decrease the temperature,
- + to increase the temperature.

An adjustment around 21 will provide an agreeable temperature level. However, depending on your preference, anything between 18 and 24 is quite normal.

For optimum comfort, it is recommended to avoid an adjustment difference greater than 3 between right and left.

Note : Actual temperatures experienced in the passenger compartment are dependent on external factors and for this reason might not be identical to those displayed.

On entering the vehicle, the inside temperature may be much colder (or hotter) than would be comfortable. It serves no purpose to alter the temperature displayed in an attempt to attain your preference more rapidly. The system automatically does all in its power to make up the difference in temperature as soon as possible.

3 - Adjustment of the air blower speed

The air blower operates only when the engine is running (except when the REST function is activated).

To adjust the flow of air, press on the button :



to increase the air flow



to decrease the air flow (this button also has the REST function)

The level of air flow is indicated on the display by the progressive filling of the ventilator blades.

Note : If you place the air blower on position 0, the system is deactivated. The air blower display will be empty, with the indication OFF.



Function for retaining ventilation with the engine switched off

The REST function is available when you switch on the ignition and when you stop the engine.

This function allows you to retain ventilation in the passenger compartment for a few minutes, even with the engine stopped.

When you leave the vehicle, any passengers present can still have the benefit of air circulation, even though the engine is not running.

(Function for retaining ventilation with the engine switched off : REST function, continued...)

Engine stopped, ignition switched on :

- The displays will light up, with the air blower shown empty as long as the function is available.
- A press on the REST button activates the function for a timing of just a few minutes. Two blades of the blower will fill to signify that the function is active.
- It can be deactivated and reactivated during the timing.
- At the end of the timing, the display will go off.

On stopping the engine :

- The displays remain lit up, the blower is shown empty and the function can be activated for 30 seconds.
- A press on the REST button during the 30 seconds activates the function for a timing of several minutes. The duration and availability of the function are variable according to the state of charge of the battery (a protection to guarantee engine starting). Two blower blades fill up to signify that the function is active. It remains active, even after the doors have been locked, until the end of the timing.
- A further press before the end of the timing definitively stops the function.

Note : This button does not activate the air conditioning, only the air blowers. In the REST function, the air flow and distribution are controlled automatically and you cannot modify them.

4 - Adjustment of the air distribution

- Press on button **4** so that the air flows scroll successively on the display.



The air distribution you have chosen is confirmed by the lighting of the corresponding warning lamps in the display.

There are 7 possible adjustments.

5 - Air recirculation

This button activates the recirculation of air within the passenger compartment and also has an automatic function.

- 1**  **Entry of air in automatic mode** (activated by default, in automatic comfort regulation)

Automatic mode makes use of an air quality sensor. This analyses the air and isolates the passenger compartment from the exterior as soon as it detects the presence of pollutants. Then it automatically activates recirculation of cabin air.

- 2**  **Closing of the air inlet**
- Press on button **5** to close off the entry of air from outside.

Whilst retaining the other adjustments, this position enables the driver at any time to exclude any disagreeable odours or fumes coming from outside the vehicle.

It should be cancelled as soon as possible to permit renewal of cabin air and to prevent misting.

Entry of air (manual mode)

- 3** - Press on button **5** to activate entry of air from the outside. The warning lamp goes out.

- Press once on button **5** to return to the initial status (entry of air in automatic mode).

Note : The air recirculation can also be accessed by means of a press on the control located low down to one side of the steering wheel (see « Fixed centred controls steering wheel »).

6 - Adjustment mode for the rear passengers



This button decides whether or not the rear passengers may use their adjustment controls.

There are three possible statuses for this button :

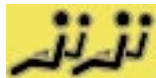

Locking of the rear passenger controls

The driver imposes his adjustment on the rear passengers.



Authorisation of the rear passenger controls

The rear passengers can use their adjustment controls at their convenience.



Closing of the air flow for the rear passengers

The supply of air is cut off.

With additional air conditioning, in cold weather you are advised to close the supply of air to the rear passengers (no hot air distribution possible via these air vents).

7 - Panel display mode : black panel function



This function turns the displays and panel backlighting on or off.

- Function activated, a press on any button will light up the screen temporarily.
- A press on button 7 deactivates the function, lighting of buttons and screen is again permanent.

Note : This function optimises notably the visual comfort for driving at night.

8 - Deicing / demisting of the rear screen

This can only operate when the engine is running.

- Press on button 8 to activate/deactivate the electric deicing of the rear screen and, according to version, of the exterior rear view mirrors. The warning lamp lights up and the symbol appears on the display.

It switches off automatically to prevent excessive consumption of power

9 - Rapid deicing / demisting of the front and rear windows

- Press on button 9. The warning lamp lights up.



This function gives a rapid deicing / demisting of the vehicle simultaneously with :

- front deicing at optimum temperature,
- optimum air flow,
- recirculation prohibition,
- deicing of the rear view mirrors and heated rear screen,
- air conditioning, if necessary.

Press again on button 9 or on « **AUTO** » to stop the function. Deicing of the rear view mirrors and heated rear screen remains activated.

10 - Air conditioning

- Press on button 10 to activate the air conditioning. The **A/C** warning lamp lights up.

AUTOMATIC AIR CONDITIONING

B. PASSENGER CONTROL PANELS

1. Front passenger

III



The front passenger can adjust his/her temperature control independently at any time by pressing buttons + and -.



The front passenger controls the adjustment of his/her own temperature.



The temperature for the passenger is indexed on that for the driver.

2. Rear passengers (right/left)



By default, in **AUTO** position, the adjustment of the air flow is aligned on the front ventilation.

- Rotate the button to decrease or increase the air flow.

Note : you can adjust the air flow only if the driver enables you to (see button **6** of the driver's control panel).



Additional air conditioning allows you to optimise comfort levels in warm weather conditions. It produces additional fresh air which is supplied using the rear air vents. The supply of warm air via the rear air vents is not possible using this system.

C. REAR PASSENGER CONTROL PANELS (RIGHT / LEFT)

1. Adjustment of temperature

The rear passengers can adjust their temperature controls independently via buttons + and -.

Note : Their preference cannot be greater than that of the driver by more than 2. The reaching of this maximum preference is confirmed by the flashing of its display.

2. Adjustment of air blower speed

The air blower operates only when the engine is running.

To adjust the flow of air, press on button :



to increase the air flow



to decrease the air flow

The level of air flow is indicated on the display by the progressive filling of the ventilator blades.

By decreasing the flow to zero, you deactivate the air conditioning system (OFF).

Note : you can adjust the temperature and the air flow only if the driver enables you to (see button 6 of the driver's control panel).



This warning lamp signifies that **the passenger controls are locked**, you can adjust neither the temperature nor the air flow, which remain aligned on the preferences of the driver.



This warning lamp indicates that the **supply of air is cut off**.

This position is recommended in cold weather conditions, as the air vents do not supply warm air.



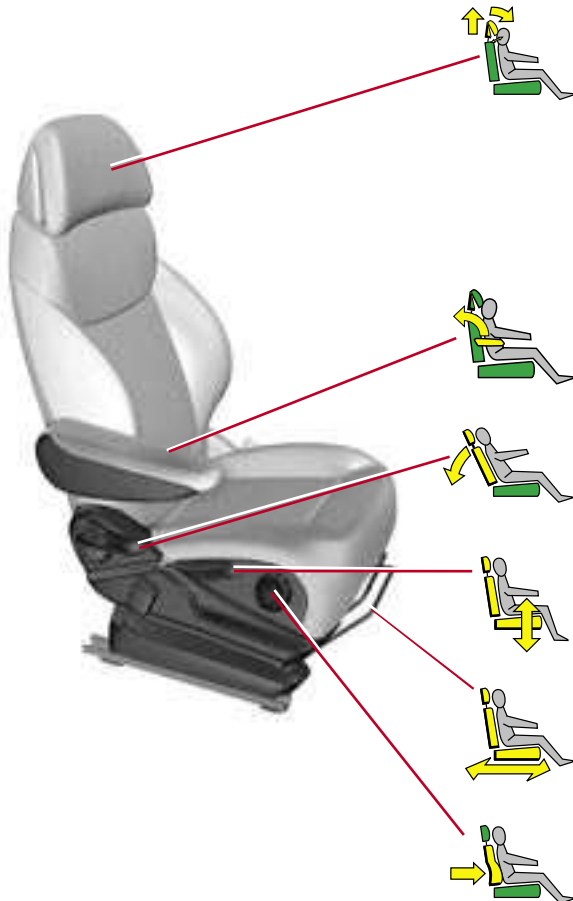

Head restraint

To raise it, pull it upwards. To lower it, press on the control as well as on the head restraint. The adjustment is correct when the top of the head restraint is level with the top of the head. It can also be adjusted for tilt.

To remove it, press on the unlocking button and pull it upwards.

To adjust the head restraint fore/aft, move the base of the head restraint to obtain the position desired.

Note : Never drive without the head restraints fitted.

Armrest

To adjust the position of the armrest, pull it up and then fully down, and then raise it to the desired position.

Backrest angle

Action the control and adjust the angle of the backrest.

It is possible to incline the backrest 45° rearwards by tilting it until it locks ; to unlock it, lift the control.

Driver's seat height adjustment

Raise or lower the the control the number of times necessary to obtain the position desired.

Lumbar support

Rotate the control until you attain the position desired.

Longitudinal adjustment

Raise the control bar, then slide the seat to the position desired.



Electric adjustments :

❶ Adjustment of seat height and angle, longitudinal adjustment



❷ Adjustment of backrest angle and lumbar support

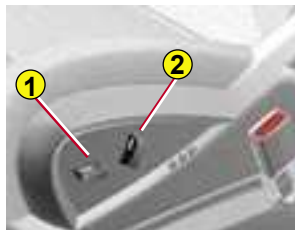

❶ Raise or lower the front of control 1 to raise or lower the front of the seat base (on driver's seat).



❶ Raise or lower the rear of control 1 to raise or lower the seat.



❶ Action control 1 forwards or rearwards to slide the seat fore / aft.



❷ Push the top of control 2 forwards or rearwards to adjust the backrest angle.



❷ Raise or lower control 2 to increase or decrease the lumbar support.

Note : The seats can also be adjusted on a temporary basis :

- on opening one of the front doors.
- after switching off the ignition.



Heated seats

The front seats can be heated independently. Use the controls on the inner sides of the seats and choose one of the three heat intensities below

0 : Stop.

1 : Slight heat.

2 : Medium heat.

3 : Strong heat.

The seat temperature will adjust automatically.

Note : the heated seats only function when the engine is running.

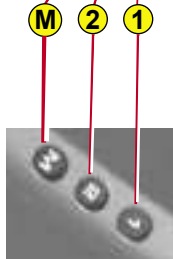

Memorisation of driving positions

You can pre-set two driving positions via the buttons located on the side of the seat.

Memorising a driving position

To pre-set a driving position :

- With the ignition on, adjust your seat and your rear view mirrors.
- Press on button **M** then immediately on button **1** «first driving position » or button **2** «second driving position ».

The memorisation will be confirmed by a sound signal. Memorisation of a new position cancels the previous one.

To recall a memorised driving position

Vehicle stationary, ignition switched on or engine running

- Press briefly on button **1** or **2** to recall the corresponding pre-set position.

Note : after five consecutive recalls of a pre-set position, the function will be deactivated until the engine is started.

Vehicle in motion

- Keep button **1** or **2** pressed to recall the corresponding pre-set position.

Do not attempt to pre-set a driving position while the vehicle is moving.

REAR SEATS

III

Examples of seat configurations Grand C4 Picasso



7 seats



6 seats



Maximum loadspace



5 seats



4 seats

Examples of seat configurations C4 Picasso



5 seats



4 seats



3 seats



Maximum loadspace

For easy modification of your interior vehicle space, all the rear seats can be individually folded : onto the second-row floor, and under the third-row floor (in the case of the Grand C4 Picasso). You can then have a load floor that is continuous up to the front seat backrests.

SECOND ROW SEATS

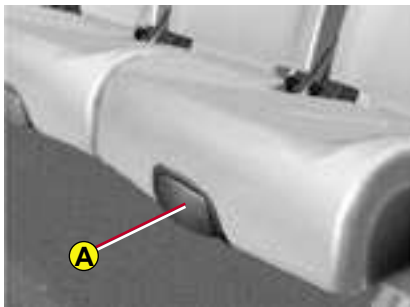

LONGITUDINAL ADJUSTMENT

Lift the control **A**, located at the front of the seat, then adjust the seat into the position desired.

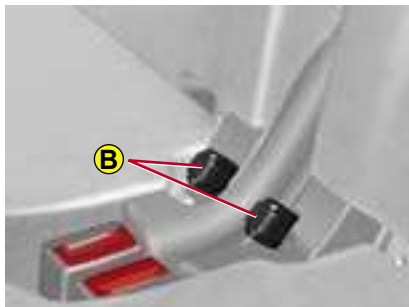

THE « COMFORT » POSITION

The 3 second-row seats are independent of each other and all the same width. They all can have a « comfort » position.

To place the seat(s) in the comfort position

- Pull on the control **B**.

The backrest reclines and the seat base pivots slightly.

To return the seat to the initial position

- Pull on the control **B** and allow the seat to come forwards.



REAR HEAD RESTRAINTS

The rear head restraints have two possible positions :

1. a stowed position for when the seats are not occupied,
2. a deployed position to assure passenger safety, by raising the restraints to their locking point.

To lower the head restraints

- Press on the unlocking button.
- Press on the top of the head restraint.

To raise the head restraints

- Pull the head restraint upwards as far as it will go.
- Press on the unlocking button and pull the head restraint upwards.

IMPORTANT : Always supervise any movements of seats by children.

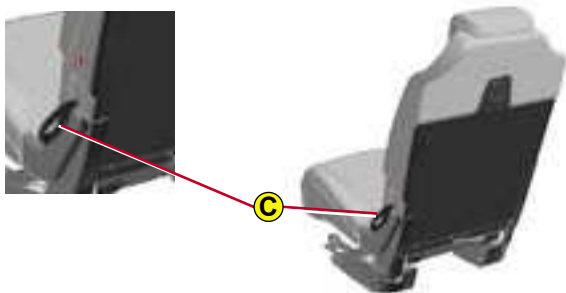

Each seat can be folded onto the floor to enable you to modify your vehicle's interior space.

TO FOLD THE SEATS

- Pull on the control **C** upwards as indicated by the arrow, to unlock the seat. Push the backrest slightly forwards so that the backrest pivots, folding onto the seat base. The assembly then lowers onto the floor.

TO RETURN THE SEATS TO THE UPRIGHT POSITION

Raise the backrests and push them rearwards so that they lock in position

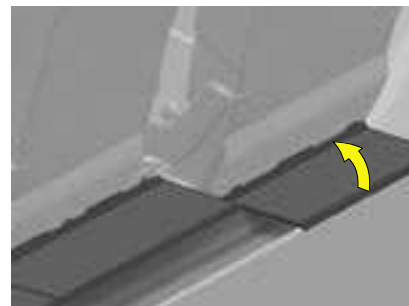

PLATES BEHIND THE SECOND ROW SEATS

Plates below the second row seats provide the bottom of the boot space with rigidity. They automatically follow the seat movements (e.g. longitudinal adjustment, folding).

A storage area is available underneath the plates.

IMPORTANT : Always supervise any movements of seats by children.

SECOND ROW SEATS

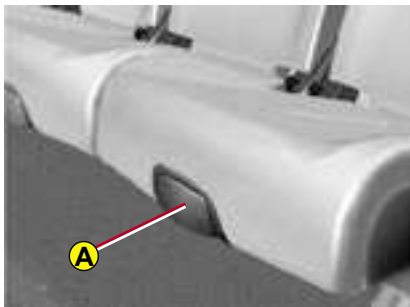

LONGITUDINAL ADJUSTMENT

Lift the control **A**, located at the front of the seat, then adjust the seat into the position desired.

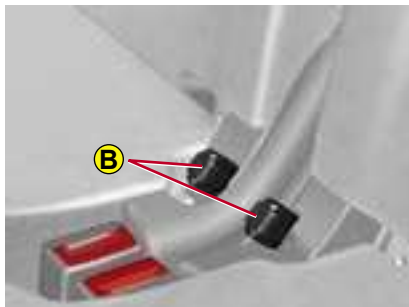

THE « COMFORT » POSITION

The 3 second-row seats are independent of each other and all the same width. They all can have a « comfort » position.

To place the seat(s) in the comfort position

- Pull on the control **B**.

The backrest reclines and the seat base pivots slightly.

To return the seat to the initial position

- Pull on the control **B** and allow the seat to come forwards.



REAR HEAD RESTRAINTS

The rear head restraints have two possible positions :

1. a stowed position for when the seats are not occupied,
2. a deployed position to assure passenger safety, by raising the restraints to their locking point.

To lower the head restraints

- Press on the unlocking button.
- Press on the top of the head restraint.

To raise the head restraints

- Pull the head restraint upwards as far as it will go.
- Press on the unlocking button and pull the head restraint upwards.

IMPORTANT : Always supervise any movements of seats by children.

SECOND ROW SEATS - GRAND C4 PICASSO

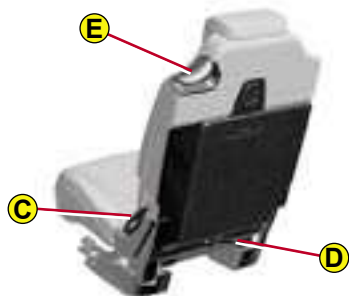

Each seat can be folded onto the floor to form a flat surface, thus enabling you to modify your vehicle's interior space.

TO FOLD THE SEATS

From the exterior

- Pull on the control **C** upwards, as indicated by the red arrow, to unlock the seat. Push the backrest slightly forwards, so that the backrest pivots, folding onto the seat base. The assembly will then lower onto the floor.

Before moving the third-row seats, return the second-row rigid plates to their initial position and lock them.

Emergency exit : Should the first system fail (control C), the control D is available for use by third-row passengers to accelerate their exit.

IMPORTANT : Always supervise any movements of seats by children.

From the boot (in the loading situation, for example)

You can fold the second-row seat(s) from the boot, having first folded the third-row seats.

- Pull on the control **D** to unlock the chosen seat, push the backrest gently forwards.

TO RETURN THE SEATS TO THE UPRIGHT POSITION

1. Return the second-row seat bases to their initial position and lock them in that position.
2. Raise the backrests and push them rearwards so that they lock in position.

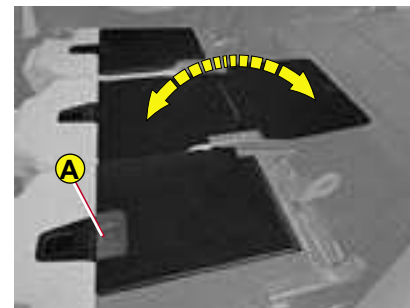

RIGID PLATE

Each second-row seat backrest has a rigid plate attached.

This plate enables you :

- to have a continuous load surface in the boot, whatever the positions of the seats,
- to avoid having objects sliding under the second-row seats.

To unlock / lock the rigid plate :

- Slide the latch **A** on the plate downwards, to unlock.
- Return the plate to the upright position, then slide the latch **A** upwards, to lock.

Note : Before deploying the rigid plates, check that the second-row seats are slid as far as possible rearwards. 5-seater configurations do not have these rigid plates.



« CINEMA SEAT » POSITION

This position allows you to free up space between the first row and the second row.

Pull the control **E** under the seat.

Note : This position is possible with the lateral seats.



ACCESS TO THE THIRD ROW SEATS

The third-row seats can be accessed via the lateral second-row seats.

1. Pull the control **E**. The seat unlocks and the seat base comes up against the backrest.
2. Hold the control **E** in the raised position, pushing forwards. The whole slides towards the front seat.
3. Raise and lock the rigid plate. Space becomes free behind the seat, the third-row passengers can get to their seats.

To exit the third-row seat positions :

1. Hold the control **E** in the raised position. The seat unlocks and the seat base comes up against the backrest.
2. Push the seat backrest, still holding the control **E** in the raised position.

Note : if the table on the back of the first-row seat is down, close it to enable this operation.

Repositioning the seat, from the exterior, with the door open

If there are passengers seated in the third row :

1. Manually return the assembly as far as possible rearwards. The seat does not return as far as the maximum aft position, so as to retain leg space for the third-row passengers.
2. Fold the seat base.

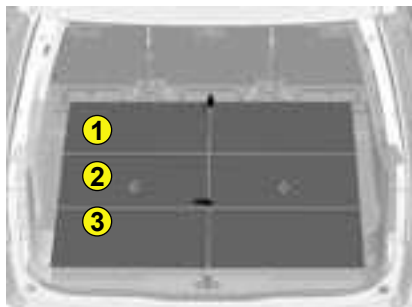

Two rigid concertina plates, which cannot be separated from the vehicle, are arranged on each of the third-row seats.

- If the seats are folded, the concertina plates then cover the seats and completely conceal them.
- If the third-row seats are upright, the concertina plates are folded and provide a totally flat load surface behind the seats.
- With the third-row seats upright, alternatively the concertina plates folded in the vertical position will allow objects to be stowed.

To fold the concertina plates :

Pull on the control, the 3 sections of the plate will fold concertina-wise.

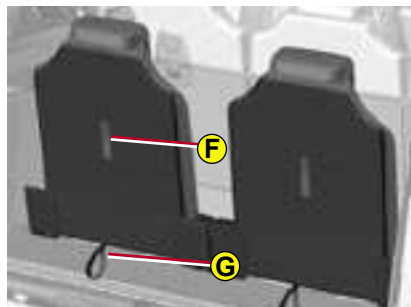

TO RETURN THE SEATS TO THE UPRIGHT POSITION

1. Return the second-row rigid plates to their initial position and lock them.
2. Having folded your concertina plate, pull on the control **F** located behind the seat backrest. The backrest pivots rearwards, pulling the seat base with it. The seat locks in the open position.

TO STOW THE SEATS

1. Return the second-row rigid plates to their initial position and lock them.
2. Lower the head restraints.
3. Correctly position the concertina plate vertically behind the seat.
4. Pull on the control **G** located at the bottom of the seat backrest. The seat unlocks.
5. Next push the backrest gently forwards. The backrest pivots, folding onto the seat base. The seat base then folds into the stowage area provided for that purpose.
6. Reposition the concertina plates over the folded seats.

Before moving the third-row seats, return the rigid plates of the second-row seats to the upright position and lock them.

Do not try to fold a third-row seat that has not first had the backrest fully locked in place.

Do not leave objects either on or underneath the seat bases of the third-row seats when you are folding them.

Do not leave your hand on the control G as you fold the seats, as you risk trapping your fingers.

FEATURES OF THE 4 SEATER LOUNGE VERSION

III



A Lounge version is available in the 5 seater model. This has two second-row seats that are identical to the first-row seats, providing greater comfort for rear passengers.

ADJUSTING THE SEATS

The seats have the following adjustments :

- head-restraint adjustment,
- backrest angle,
- greater longitudinal adjustment,
- height-adjustable armrests.

Refer to the page « FRONT SEATS - Manual adjustments» for the operation of the adjustment controls.



LUGGAGE COVER BEHIND THE SEATS

A flexible luggage cover positioned behind the second-row seats enables you to prevent objects from sliding under or between the second-two seats, as well as concealing the contents of your boot from outside view.

It is fixed to the floor by two hooks located behind the seats and anchored at special points on the rear pillars.

This flexible luggage cover is movable and can be rolled up for stowage behind the second-row seats.



SEAT BELTS

For safety reasons, always attach your seat belt before positioning the armrest between yourself and the door.

STORAGE POCKETS

Two storage pockets are located on the insides of the Lounge version seats.

REAR CENTRAL SEAT BELT - C4 PICASSO AND GRAND C4 PICASSO

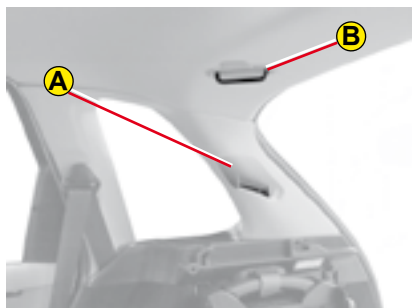

Installation of the seat belt (C4 Picasso)

1. Open the cover **A**.
2. Remove the belt tongues from their housing.
3. Bring the belt tongues up to the relay ring **B**.
4. Insert the attachment then pass the tongues through the ring.
5. Reclose the cover **A**. Make sure that the belt is correctly positioned in the recess in the cover provided for this purpose.



Stowage of the belt tongues (C4 Picasso)

- Operate in reverse order to stow the belt tongues.

Note : You may opt to leave the seat belt in the relay ring even if not using it.

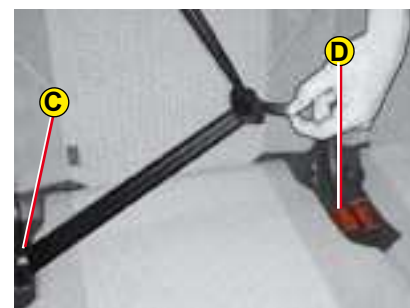

Routing of the seat belt (C4 Picasso and C4 Grand Picasso)

- Insert the tongue **C** into the buckle on the right, then insert the second tongue **D** into the buckle on the left.



Before use

For safety reasons, it is essential that the seat belt passes through the relay ring. To prevent any damage to seat belts and in order not to get them jammed, take care to stow them on the sides of the backrests.

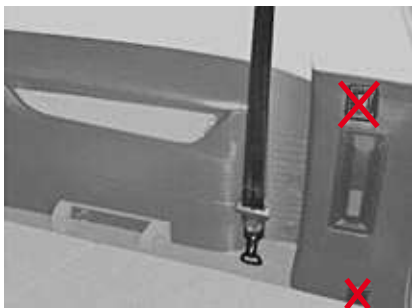

Requirements for the third-row passenger seat belts

Take care to attach the third-row passenger seat belts on the rings provided for this purpose.

Do not attach the belts on the anchoring points marked with a red cross (see illustration above).



Stowing the tongue of the third-row seat belt

Secure the tongue in the place provided on the rear pillar trim.

Note : The third-row passenger seat belts that are not being used can be stowed in order to free up load-space and facilitate use of the luggage cover.



Before use :

To avoid damaging or jamming the seat belts, take care to stow them on the sides of the backrests.



The passenger airbag can be deactivated.

Deactivation of the front passenger airbag

To be able to use a “rear-facing” child seat in the front passenger seat position, it is imperative to deactivate the passenger airbag.

For that :

- With the ignition switched off, insert the key into the switch **A** located in the glovebox.
- Turn the key to the « **OFF** » position, the passenger airbag is deactivated.

The front passenger airbag deactivation warning lamp comes on permanently on the display.



Reactivating the front passenger airbag

Do not forget to reactivate the airbag function.

For that, with the ignition switched off, insert and turn the key to the « **ON** » position. The airbag is activated.



In the event of a malfunction, the « airbag fault » warning lamp comes on and a message displays.

In the front passenger’s seat position, it is imperative to deactivate the front passenger’s airbag if you are installing a “rear-facing” child seat there.

Otherwise the child risks being killed or seriously injured should the airbag deploy.



Manual control

The rear doors are locked by operating the lever. When the manual safety is in use, the aperture is at an angle.



Note : with the ignition on, if the child safety is activated for the two rear doors, the warning lamp comes on then goes out again approx. 10 seconds after the engine is started.



Electric operation

The electrical safety is activated by pressing the control located to the rear of the electric windows panel. This prohibits movement of the rear electric windows and opening of the rear passenger doors.

It is still possible to open the doors from the outside, provided the vehicle is not locked.

Note : Activation of the function is confirmed by the temporary lighting of the warning lamp accompanied by a message.



When the ignition is switched on, the warning lamp comes on then goes out again approx. 10 seconds after the engine is started.

CHILD RESTRAINTS

TABLE SUMMARISING CHILD SEATS SECURED BY MEANS OF THE VEHICLE SEAT BELT

In conformity with Directive 2000/3, the table tells you to what extent each of the seat positions in your vehicle may take a child seat that is secured by means of the vehicle seat belt and approved as « Universal » (child seat that can be used in any vehicle in conjunction with the vehicle seat belt) as a function of the weight of the child.

Consult « User Precautions », chapter on « Child Safety » at the end of this handbook, in order to ensure that you are installing your child in conditions of maximum safety.



	Seat position	Weight groups established by legislation			
		< 10 kg and < 13 kg (groups 0 and 0+)	9 – 18 kg (group 1)	15 – 25 kg (group 2)	22 – 36 kg (group 3)
1 st row*	Front passenger	U	U	U	U
2 nd row	Lateral	U	U	U	U
	Central	U	U	U	U
3 rd row**	Lateral	U	U	U	U

U : Seat position suitable for the installation (in conjunction with the vehicle seat belt) of a universal rear-facing child seat and a universal forward-facing child seat.

***** : Before installing your child in the front passenger seat position, refer to the chapter on Child Safety, paragraph on « Rules for transporting of children in the front passenger seat position ».

****** : Applies only to the 7 seater model.



For seats in groups 1, 2 and 3, check that the child seat is correctly secured on the backrest of the vehicle seat. If necessary, remove and stow the head restraint.

It is imperative to deactivate the front passenger airbag if you are installing a « rear-facing » child seat in the front passenger seat position.

Take care to comply with the fitting instructions given in the child seat manufacturer's user guide.

To install a large child seat, rear-facing or forward-facing, on one of the rear seats, slide the seat rearwards so that the child seat is not hampered by the front seat.

CHILD RESTRAINTS

TABLE SUMMARISING THE INSTALLATION OF ISOFIX CHILD SEATS

In compliance with European legislation (ECE 16), this table indicates which of the ISOFIX child seats can be installed in seat positions in your vehicle that are equipped with ISOFIX anchoring points.

For ISOFIX universal and semi-universal child seats, the ISOFIX size class, defined by a letter from **A** to **G**, is shown on the child seat to the right of the ISOFIX logo.

	Child weight / age given as a guide									
	Less than 10 kg (group 0) Up to around 6 months		Less than 10 kg (group 0) Less than 13 kg (group 0+) Up to around 1 year old			9 to 18 kg (group 1) From 1 to 3 years approx.				
Type of ISOFIX child seat	Shell seat		« Rear-facing »			« Rear-facing »		« Forward-facing »		
ISOFIX size classes :	F	G	C	D	E	C	D	A	B	B1**
Front passenger seat	X		IL-SU			IL-SU		IUF		
ISOFIX rear lateral seats	IL-SU*		IL-SU			IL-SU		IUF		
ISOFIX central rear seat	X		IL-SU			IL-SU		IUF		

IUF : Seat position suitable for installation of a « universal » ISOFIX child seat : ISOFIX « forward-facing » child seat equipped with a top belt attaching to the top ring on the vehicle's ISOFIX positions.

IL-SU : Seat position suitable for installation of a « semi-universal » ISOFIX child seat : ISOFIX « rear-facing » child seat equipped with a top belt and ISOFIX « shell » child seat with a top belt.

* The ISOFIX shell is secured to the bottom rings on an ISOFIX position, occupying 2 rear seat positions.

** To install ISOFIX child seats type **B1**, remove the head restraints from the seats.



Do not install seats equipped with a bar.

It is imperative to deactivate the front passenger airbag if you are installing a « rear-facing » child seat in the front passenger seat position.

Take care to comply with the fitting instructions given in the child seat manufacturer's user guide.

To install a large child seat, rear-facing or forward-facing, on one of the rear seats, slide the seat rearwards so that the child seat is not hampered by the front seat.

ISOFIX anchoring points and the ISOFIX fixing system

Your vehicle is approved to the new ISOFIX regulations. The front passenger seat position and the second row seat positions on your vehicle are equipped with the regulation ISOFIX anchorages.

Incorrect installation of a child seat in the vehicle compromises the protection of the child in the event of a collision. The ISOFIX system enables you to eliminate these risks arising from poor installation. The ISOFIX fixing system offers you a child seat fixing method that is strong, reliable and convenient.

Consult the legislation in force in your country before installing your child seat « forward-facing » in the front passenger seat position.

The ISOFIX child seat recommended for your vehicle is the ISOFIX RÖMER Duo:

It is marketed in the CITROËN network. It is equipped with a top belt and so it is approved as an “ISOFIX universal” child seat.

If it is installed in a rear seat position, the vehicle's corresponding front seat should be adjusted so that the child's feet do not touch the backrest of this front seat.

This ISOFIX child seat can also be installed in seat positions that are not equipped with ISOFIX anchoring points. In this case, it is compulsory to secure it to the vehicle seat by means of the vehicle seat belt.

In the front passenger's seat position, it is imperative to deactivate the front passenger's airbag if you are installing a « rear-facing » child seat there. Otherwise the child risks being killed or seriously injured should the airbag deploy.

Take care to comply with the fitting instructions given in the child seat manufacturer's user guide.

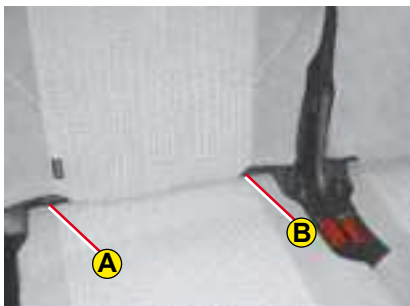

The ISOFIX anchoring system

The three second-row rear seats as well as the front passenger seat position on your vehicle are equipped with the regulation ISOFIX anchoring points.

There are 3 rings for each seat position:

- Two « bottom » rings **A** and **B**, between the seat cushion and the backrest. They are approx. 28 cm apart.
- A « top » ring **C**, behind a cover at the top of the backrest for the second-row seats, and at the bottom right of the seat base for the front passenger seat position.

ISOFIX child seats have two latches which are easy to attach on the two « bottom » rings **A** and **B**.

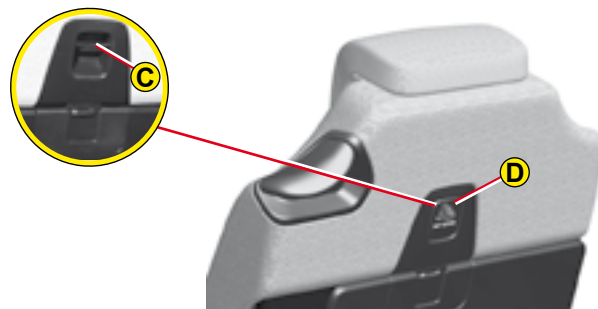

Top ring C

1. To attach the top ring, unclip the cover **D**.
2. Raise the head restraint of the vehicle seat, then pass the attachment between the uprights.
3. Next secure the attachment on the « top » ring **C** (second row seats).
4. Tension the top belt.

This fixing system is designed for children weighing up to 18 kg.

AIRCRAFT-STYLE REAR TABLES



Rear table stowed

Rear tables

The backrests of the front seats are fitted with aircraft-style tables. These incorporate a cup-holder **A** and a retaining strap **B**, for the placing of objects.

Operation table

- Pull the table downwards to open.
- To restow the table, raise it until the latch locks.

Note : For safety reasons, these collapse downwards if excessive pressure is exerted.

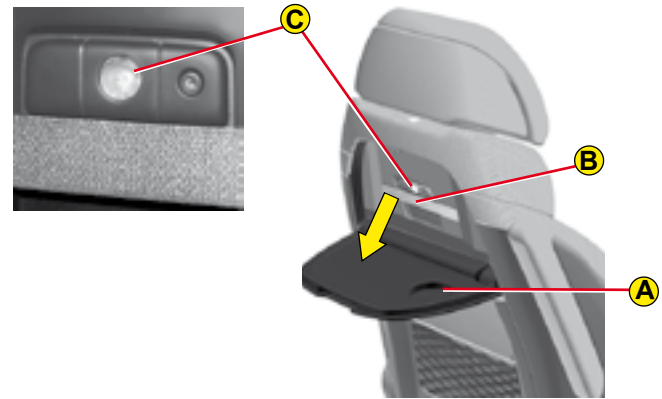

Rear table opened

Individual reading lamps

Reading lamps **C** may be incorporated in the front seat backrests, behind the tables. These light the surface of the tables without disturbing the other passengers.

They are accessible only while the table is down.

- Press on the On/Off button to turn the lamp on or off.



INTERIOR LAMPS

1. Reading lamps

A press on one of the buttons switches the corresponding spot-lamp on or off.

They do not come on if the ignition is switched off or if the vehicle is in economy mode.

Note :

- the opening of a door switches the interior lamps on.
- the opening of the tailgate switches the third-row interior lamp on, also the boot lamps.

2. Interior lamp with three positions



In this position, the interior lamp comes on when you open a door or the boot.



In this position, it is deactivated and thus permanently off.



In this position, lighting is permanent.

Automatic illumination of the interior lamps



They come on immediately you unlock the vehicle or open a door.

They go out 30 seconds after the doors have been closed, or when the ignition is switched on.

When you leave the vehicle :

- they come on when you remove the ignition key (for about 30 seconds), or when a door is opened.
- they go out after 30 seconds with the doors closed, or immediately the vehicle is locked, or after 10 minutes if a door is open.

« PANORAMIC GLASS ROOF » LAMPS

The panoramic glass roof lamps have two operating modes :

- automatic lighting when you open a door or when the front interior lamp is in the permanent position,
- permanent lighting.



AMBIANCE LIGHTING

You have in your vehicle a system of ambiance lighting that is warm and convivial.

It casts a gentle, orange-tinted light.

You can adjust the lighting by pressing on the control **A**.

This activates the light sources which are located as follows :

- on the sides of the front and rear doors,
- on the front and rear interior door handles,
- on the dashboard,
- at the roof.

Operation

The control **A** :

- activates/deactivates the ambiance lighting,
- selects the lighting intensity.

The adjustment is memorised.

To **increase** the lighting intensity :

- Press a few times on the right of the control **A** to obtain your brightness preference.

To **decrease** the lighting intensity :

- Press a few times on the left of the control **A** to obtain your brightness preference.

Note : This lighting is available at night or in conditions of poor daylight.

COURTESY LIGHTING

The automatic courtesy lighting consists of the footwell lamps, the interior lamps and the ambiance light sources.

FRONT DOOR POCKETS WITH AUTOMATIC LIGHTING

The lighting for the door pockets comes on automatically when you place a hand inside one of the compartments.

It goes off after a few seconds when you take your hand away.

READING LAMPS ON SEAT BACKRESTS

There are spotlamps incorporated in the backrests of the front seats, behind the rear tables (see « Aircraft-style rear tables »).

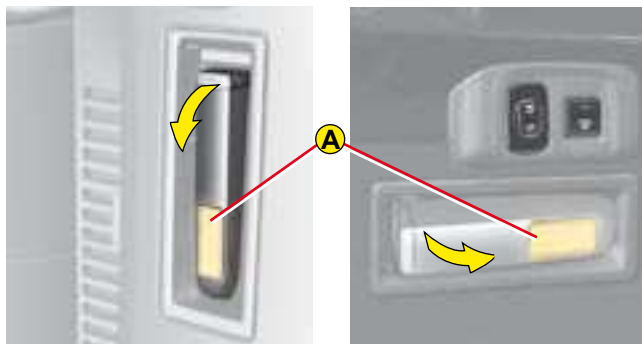

Portable flash light for Grand C4 Picasso

Portable flash light for C4 Picasso

The portable flash light, connected to the boot wall, possesses the double function :

- boot lamp,
- portable lamp.

The boot lamp **A** comes on automatically when you open the boot.

The portable lamp operates on rechargeable batteries.

Note :

- Never replace the rechargeable batteries with ordinary batteries.
- Replace them with identical ones of the NiMH type.
- Respect the polarities when you are positioning these rechargeable batteries.
- See the procedure to be followed in the chapter « Changing bulbs », to access the rechargeable batteries.

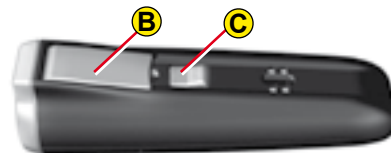

To use the portable flash light:

- Remove it from its housing by starting to pull from the top as indicated by the arrow.
- Press on the switch **C**, located on the back of the lamp, to turn it on or off.
- The bracket **B** allows you to put the lamp down for a precise purpose (for example while changing a wheel).

To stow the portable flash light:

- Always position the lamp in its housing starting from the bottom.

If it is not properly positioned, it may not recharge and will fail to come on when you open the boot.

Note:

- Putting the portable lamp back in position automatically turns it off, if you have not already done so.
- The portable lamp can stay on for a maximum of 45 minutes and recharges in a few hours as you are driving.



Glovebox

To open, pull on the handle and lower the lid.

The glovebox has an area specially for stowing two cartridges for the scented air freshener.

It may be refrigerated, according to equipment (manual gearbox), by a ventilation duct that can be closed off manually.

It is directly linked to the vehicle's air conditioning system, being supplied with fresh air whatever the requirements of the passenger compartment.

It also has automatic lighting.

Note : The refrigeration of your glovebox only operates when the engine is running and the air conditioning is on.



Dedicated refrigerated storage

Vehicles with an **electronic gearbox** or an **automatic gearbox** possess a dedicated refrigerated storage situated at the centre of the dashboard (according to version).

To open, pull on the handle and lower the lid.

The refrigerated storage has a ventilation duct. It is directly linked to the vehicle's air conditioning system, being supplied with fresh air whatever the requirements of the passenger compartment and however high the ambient temperature.

It can accommodate for example a 1.5 litre bottle and two 0.5 litre bottles.

Two cupholders are available when the lid is open.

The refrigerated storage has automatic lighting.

Note : The refrigeration of this storage area only operates when the engine is running and the air conditioning is on.



For reasons of safety, the glovebox should remain closed when the vehicle is moving.

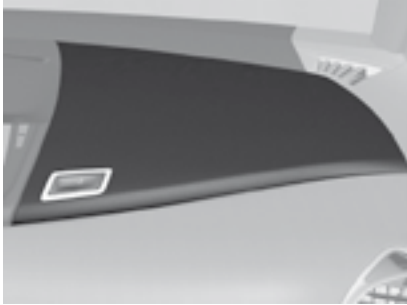

Upper storage area

This accommodates the CD changer, if the vehicle has one.

There is also an upper storage area on the opposite side.

Front door compartments

The front door pockets can hold objects equivalent in volume to a 1.5 litre bottle.

They may have their own lighting, coming on automatically when your hand approaches.

This lighting goes out automatically after a few moments when your hand is taken away.

Rear door pockets

The rear door pockets can hold objects equivalent in volume to a 0.5 litre bottle.



Second row storage

The lateral second-row occupants may also have the benefit, in certain configurations, of storage at foot level, identifiable by its handhold **A**.

Third row storage

Third-row passengers may have storage pockets in the side panel and each of them will have a cup-holder (7 seater model).

For reasons of safety, storage compartments should be kept closed when the vehicle is moving.



CENTRAL CONSOLE

The central console contains :

- **two cup-holders.**
- **a 12V accessories socket** (Maximum power : 120W).

The latter is operational when the ignition is on.

Note : There may be a second 12V socket in the boot, operational even with the ignition switched off.

- **a cigar lighter.**

Press and wait for a few moments for the lighter to deploy automatically. The cigar lighter comes out slightly to enable you to grasp it. It can act as a 12V socket (120 W).

- **a movable ashtray.**

This is in one of the console's cup-holders: it can be used in the cup-holders on the rear tables.

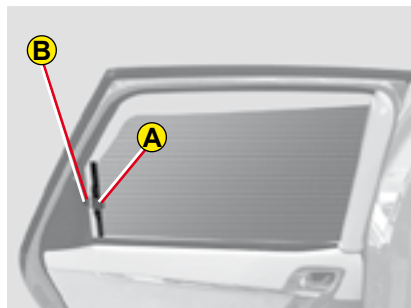

SUN BLINDS (C4 Picasso)

Second row

- Pull on the tab **A** and anchor the blind on the hook **B**.

Rear screen blind

- Pull on the tab of the blind located on the luggage cover and position the blind on the hooks.

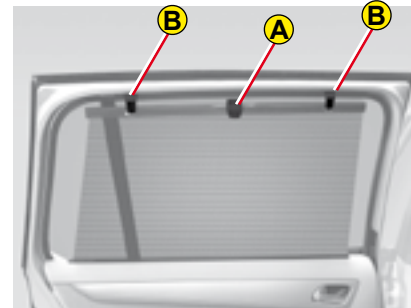

SUN BLINDS (Grand C4 Picasso)

Second row

- Pull on the tab **A** and anchor the blind on the hooks **B**.

Third-row

The blinds are incorporated in the third-row trim panels.

- Pull on the tab and anchor the blind on the hooks.

Rear screen blind

- Pull on the tab and anchor the blind on the hooks.

Sliding sun visors (see « Roof adjustments »)
Do not attach or suspend heavy objects in the environs of the sun visors (central rear view mirror rails, blind hooks, sun visor blinds, etc.)

SCENTED AIR FRESHENER

III



The scented air freshener releases a fragrance into the passenger compartment via the central air vents.

Adjustment of flow

- Rotate the button **A** to adjust (to the left to reduce, to the right to increase) or stop (maximum to the left) the flow of scented air.

Note : the central air vents have to be open.

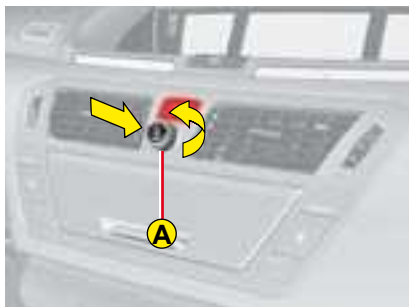

To remove the air freshener

1. Press the button **A**, rotating it a quarter turn to the left as far as it will go.
2. Remove the air freshener from the dashboard.
3. Replace the cartridge (see « Changing the cartridge »).



To insert the air freshener

After fitting or changing a cartridge :

1. Place the air freshener back in its housing.
2. Rotate it a quarter turn to the right.

Note :

- Your scented air freshener has an empty cartridge to start with.
- A cartridge lasts on average 3 months, based on 1 hour's usage per day.

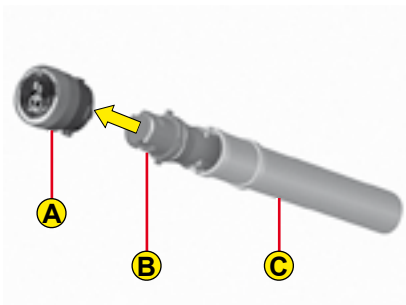

Replacing a cartridge

The recharge for the air freshener consists of a cartridge **B** and its sealed container **C**.

1. Remove the protective film **D**.
2. Place the head of the cartridge **B** on the button **A** of the air freshener.
3. Rotate it a quarter turn to lock it on the button and remove the container.
4. Insert the air freshener into its housing.

You can change cartridges at any time, keeping the used cartridges in their original containers.

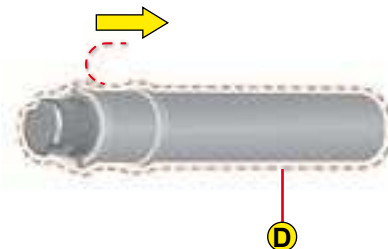

Air freshener button

The air freshener button **A** is independent of the cartridge. Cartridges are supplied without the air freshener button **A**.

The button of the air freshener **A** can only be fixed into the central dashboard with a cartridge attached.

Therefore always keep the air freshener button **A** and one cartridge.

Note : Recharges are available, according to country, either on the CITROËN Internet site or from a CITROËN dealer.

Stowage points are provided in the glovebox for storing of cartridges and containers.

For safety, use only cartridges that are provided for this purpose.

Do not attempt to take cartridges apart.

Never recharge the cartridges with fragrances not supplied by CITROËN.

Keep them out of reach of children and animals.

Avoid all contact with the skin and with the eyes.

In the event of swallowing, consult a doctor and show him the product packaging or label.

Do not install or remove a cartridge while you are driving.

OPENING THE BOOT

III

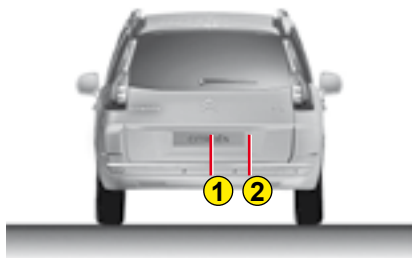

To open the tailgate

- Press on the control 1.

Note : You cannot open the tailgate if the rear screen is already open.

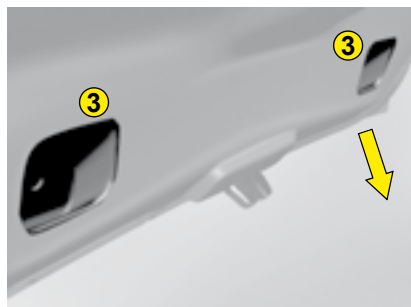

To close the tailgate

- Lower the tailgate, using one of the handholds 3, located on the inside of the tailgate trim.
- Past the balancing point, allow the tailgate to close itself (do not assist it or slow it down).



To open the rear screen

Your vehicle may have an opening rear screen.

This opening configuration gives you enhanced access to the bootspace, even if you are parked close to a wall or to another vehicle.

- Press on the control 2.

To close the rear screen

- Lower the rear screen.

Note :

- The handhold 4 is in line with the rear wiper.
- In the C4 Picasso vehicle, if the rear screen is open, you can access your bootspace by lifting the rear shelf using the tab located on the shelf.

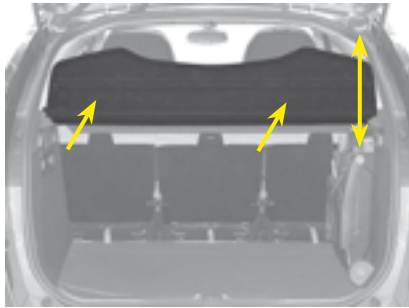

LUGGAGE COVER IN TWO SECTIONS

Rear shelf

To remove

1. Unhook the cords.
2. Push upwards then lift on each side of the luggage cover.

To refit

1. Present the luggage cover to its slots and push firmly down.
2. So that the luggage cover will rise with the tailgate, take the cords and attach them on the tailgate.

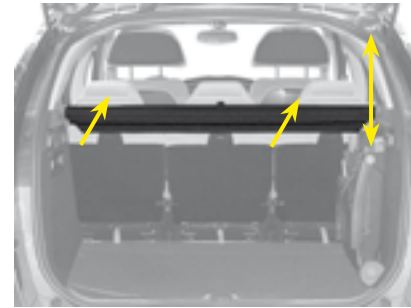

Front shelf

To remove

1. First remove the rear shelf.
2. Push upwards then lift on each side.

To refit

1. Orient the flap downwards.
2. Present the luggage cover to its slots and push firmly down.



MODUBOX

The Modubox is for use both inside the vehicle and away from the vehicle. It is composed of a shopping trolley and a flexible bag (isotherm on some versions) which can be used independently of each other depending on your needs (by detaching the fastenings on each side at the top and bottom).

To use

1. Unhook the red strap to free the Modubox.
2. Unhook the black strap then press on the round buttons on either side of the Modubox simultaneously to deploy it.

Use of the Modubox outside the vehicle

- Press on the recess on the left hand side of the Modubox to raise (or lower) the handle.

Stowage inside the vehicle

- Perform the operations in reverse to fold and stow inside the vehicle.
- If you have used your Modubox away from the vehicle, take care to reposition it correctly in the housings provided for this purpose.

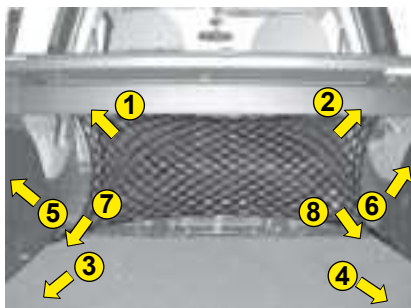

Cargo net : Grand C4 Picasso

There are 8 anchoring rings in the boot to enable you to secure your loads :

- 1 and 2 underneath the luggage-cover blind.
- 3, 4, 7 and 8 on the boot floor.
- 5 and 6 on the boot pillars.

The cargo net gives you a number of configurations depending on which of the anchoring rings you attach it to (hammock format, vertical / horizontal, on the floor or behind the second row seats), enabling you to secure a variety of objects in the boot.

Note : For reasons of safety in the event of sudden braking, it is recommended that you place heavy objects on the floor as close as possible to the backrests of the second-row seats.

Carrier bag hook

A carrier bag hook is available inside the boot on the left hand side.

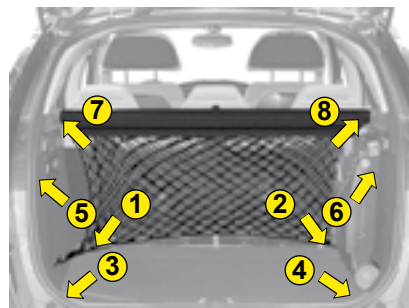

Cargo net : C4 Picasso

There are 8 anchoring rings in the boot to enable you to secure your loads :

- 1, 2, 3 and 4 on the boot floor,
- 5, 6, 7 and 8 on the boot pillars.

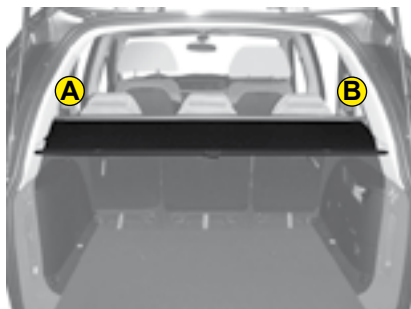

Luggage-cover blind

Position 1 : (5-seat configuration, behind the second row)

Behind the second-row seats, with the third-row seats folded away.

To install the roller :

1. Compress the left-hand end of the roller and place it in notch **A**.
2. Position the right-hand end of the blind roller in notch **B**.
3. Unroll the blind until it reaches the boot pillars.
4. Insert the guides of the blind into the rails on the pillars.

To remove the blind:

- Perform these operations in reverse order.

Note : the roller has a moving flap to avoid interference with the second-row passengers when the seats are in the reclined position.



Position 2 : (7-seat configuration)

Behind the third-row seats, this position conceals objects stowed in the boot from outside view.

To install the roller :

1. Roll up the blind, then remove the roller from its initial position.
2. Position the roller, with the blind pull bar uppermost, flap downward.
3. Fold the concertina plates in the vertical position.
4. Engage the lug on the left of the roller in notch **C**.
5. Pass the right-hand side above the third-row armrest.
6. Engage the lug in notch **D**.
7. Pull the seat belt(s) so that they will deploy without locking.
8. Unroll the blind and engage the guides into the rails on the pillars.
9. Lock the seat(s) in position.
10. Fold back the concertina plates, pressing them firmly in position.

Position 2 : (continued)

To remove the roller :

1. Push the flap towards the seat backrest.
2. Lift the concertina plate by grabbing it at the side, then position it vertically.
3. Unlock the seat by pulling the strap **G** (see « Third-row rear seats »).
4. Push the backrest towards the front.
5. Proceed in reverse order to installing.

Note : you can position the concertina plate vertically to lodge a bulkier object in the boot well.



Position 3 : (7-seat configuration, stowage position)

To install the roller :

1. Remove the blind from its current position.
2. Position the roller, with the blind pull bar uppermost, flap downward.
3. Engage the lug on the left of the roller in notch **C**.
4. Pass the right-hand side above the third-row armrest.
5. Engage the lug in notch **D**.

To remove the roller :

- Proceed in reverse order to installing.

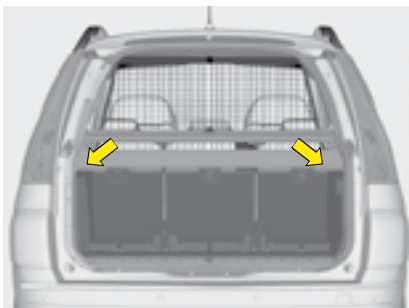

Net for retaining high loads

This enables you to maximise the vehicle's load-space.

It retains objects, preventing them from sliding towards the front of the passenger compartment.

You insert it under the roller of the luggage-cover blind, securing it on the third-row side mouldings.

Position 1 (5-seat configuration, behind the second row)

To install the roller :

1. Remove the protection covers located under the blind roller notches.
2. Position the roller under that of the luggage-cover blind.
3. Raise the flap on the blind, positioning it on top of the blind.
4. Deploy the net, passing it between the rollers and the seats.
5. Pull the net upwards.
6. Anchor it to the roof by means of the fixing points (after you have removed their covers).

To remove :

- Perform these operations in reverse order.

Position 2 (2-seat configuration, behind the first row)

To install the roller :

1. With the second-row seats folded away, remove the covers of the Isofix anchoring points located on the seat backrests.
2. Secure the roller on the Isofix anchoring points.
3. Deploy the net and pull it upwards.
4. Anchor it to the roof by means of the fixing points (after you have removed their covers).

PNEUMATIC SUSPENSION

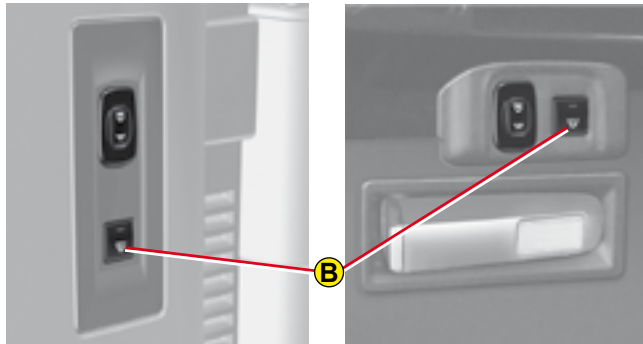

Grand C4 Picasso

C4 Picasso

The rear pneumatic suspension enhances driving comfort by maintaining a constant body height whatever the vehicle load.

OPERATION

- If there is an increase in vehicle load, a sinking of the rear of the vehicle is detected and the pneumatic springs inflate in order to compensate for the extra weight.
- If there is a decrease in load, a rising of the rear of the vehicle is detected and so the pneumatic springs deflate to return the vehicle to its nominal height.
- If the vehicle has been unused for a long period, the pneumatic springs may inflate if necessary when you unlock or open a door, so as to return the vehicle to its nominal height.

Note : If you do not reactivate the system manually, the automatic correction will be activated as soon as the vehicle starts to move. During the correction, the SERVICE warning lamp lights up and a message on the screen reminds you not to exceed 10 km/h (6 mph).

Note : the automatic correction does not function if the doors or the tailgate are open.

The automatic correction operates even if your vehicle is in economy mode.

ACTIVATION / DEACTIVATION

The automatic correction can be deactivated :

- Press on the button **B** for approximately two seconds.
 - Release the button when you hear a beep. Deactivation is confirmed by the lighting of the LED on the button **B**.
- It is essential that you should deactivate the system in the following instances :
- working under the vehicle,
 - changing a wheel,
 - transporting the vehicle on a truck or on a boot.

To reactivate the automatic correction :

- Press again on the button **B** for approximately two seconds.
- Release the button when you hear a beep. Activation is confirmed by the extinction of the LED on the button **B**.

In the event of the system malfunctioning, alert messages, always in association with the SERVICE warning lamp, will display in the instrument panel. Contact a CITROËN dealer as soon as possible.



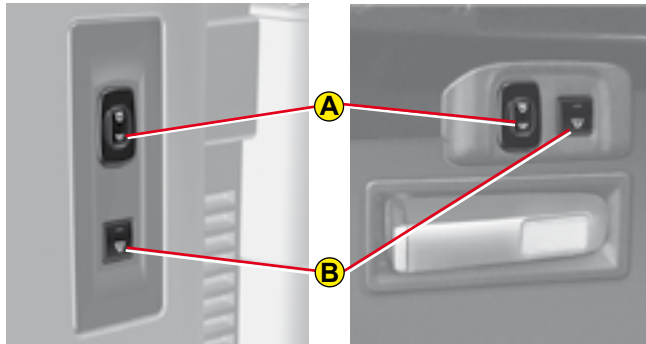

Grand C4 Picasso

C4 Picasso

The pneumatic suspension has an additional function associated with it : the possibility to raise or lower the height of the rear of the vehicle when stationary, in order to facilitate loading / unloading of the boot.

TO INCREASE THE HEIGHT OF THE BOOT SILL

- Press continuously at the top of the control **A**, which is located in the boot, on the left-hand side.

This action will be accompanied by a sound signal. You can stop the movement at any time by releasing the control.

3 beeps will confirm that the movement has gone as far as it can.

To return to the nominal height :

- Press briefly twice at the bottom of the control **A**.

TO DECREASE THE HEIGHT OF THE BOOT SILL

- Press continuously at the bottom of the control **A**.

This action will be accompanied by a sound signal. You can stop the movement at any time by releasing the control.

3 beeps will confirm that the movement has gone as far as it can.

To return to the nominal height :

- Press briefly twice at the top of the control **A**.

Note :

- If you start the vehicle without having returned it to the nominal height, the automatic correction will activate as soon as the vehicle starts to move. During the correction, the SERVICE warning lamp lights up and a message on the screen reminds you not to exceed 10 km/h (6 mph).
- The loading assistance does not function in the following instances:
 - If the button **B** is lit up,
 - in power economy mode.
- When you first use the function, press for two seconds on the control **A** to initialise the system. All subsequent actions will be followed immediately by the desired results.



Driving with the boot sill in a low position may damage the components located under the bodyshell.



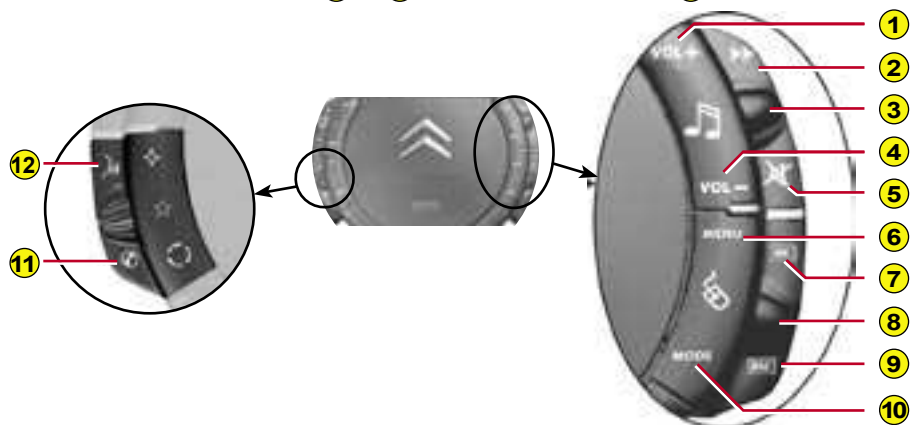
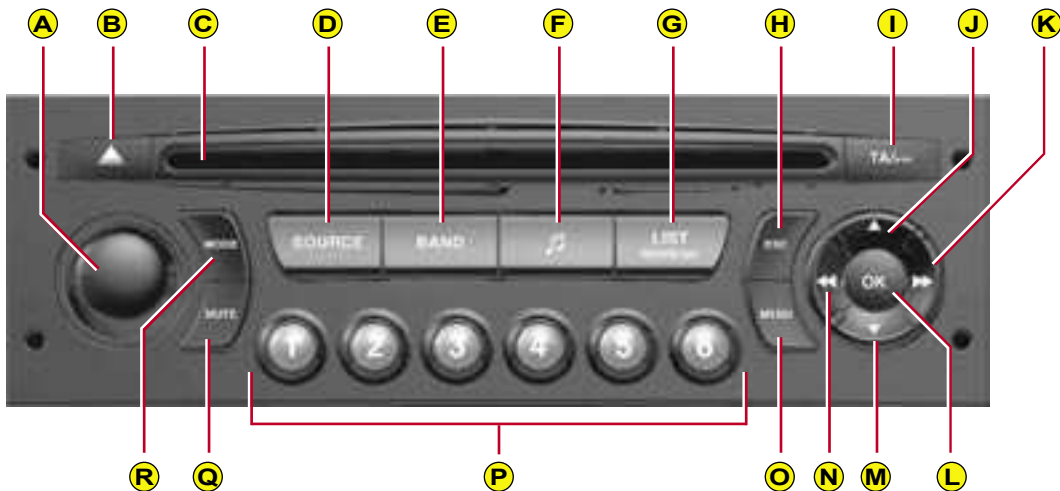

RADIO - RDS AUDIO COMPACT DISC SYSTEM WITH CD CHANGER



IV



BUTTON CONTROLS



IV



A		On / Off. Volume adjust.
B		CD eject.
C		CD aperture.
D	SOURCE	One press : Selection of sound source (Radio, CD, CD changer).
E	BAND/ AST	Short press : Selection of frequency bands and memory banks. Long press : Automatic pre-set function (Autostore).
F		Call-up of audio adjustments : Sound ambiances, bass, treble, loudness, fade, balance, speed-sensitive volume.
G	LIST	Radio source : - Short press : Display of the list of radio stations available (30 maximum). - Long press : Update of list of stations. CD source : Display of list of tracks of the CD.
H	ESC	Short press : Cancel the current operation or delete a superimposed display. Long press : Return to the permanent display.
I	TA/PTY	Short press : TA function (road information). Long press : PTY function (eélection of programme type).
J		Radio source : Manual search of higher frequencies. CD/MP3 changer source : Selection of the previous CD/CD-cover. Other sources : Scrolling in the Main Menu.
K		Radio source : Automatic search of higher frequencies. CD source, CD changer source and MP3 source : Forward search for tracks. - Long press : Fast forward with accelerated sound. Other sources : In the menus, choice of your adjustments. If your vehicle has the Bluetooth system : Selection of characters.

L	OK	Button for validation and activation/deactivation of certain functions. If your vehicle has the Bluetooth system : Answer call, end call.
M		Radio source : Manual search of lower frequencies. CD/MP3 changer source : Selection of the next CD/CD-cover. Other sources : Scrolling in the Main Menu.
N		Radio source : Automatic search of lower frequencies. CD source, CD changer source and MP3 source : Reverse search for tracks. - Long press : Rapid reverse with accelerated sound. Other sources : In the menus, choice of your adjustments. If your vehicle has the Bluetooth system : Selection of characters.
O	MENU	Display of the Main Menu. In certain countries, this control is deactivated while the vehicle is moving.
P	1-6 1-5	Radio source : - Short press : Recall of pre-set stations. - Long press : Memorisation. CD changer source : Selecting a CD.
Q	MUTE	- First press : Temporary sound pause. - Second press : Restoration of sound.
R	MODE	Selection of the type of information displayed.
S		CD changer.

CONTROLS AT THE STEERING WHEEL

The controls at the steering wheel give you access to certain functions, without you needing to use the radio-CD control panel.

1	VOL +	Volume increase
2		Radio source : Short press : Automatic search of higher frequencies. CD and CD changer source : Short press : Forward search for tracks. Long press : Fast forward with accelerated sound.
3		Radio source : Scrolling of pre-set stations. CD and MP3 source : Search of the track. CD changer source : Selection of next or previous CD.
4	VOL -	Volume decrease.
5		Mute First press : Temporary sound pause. Second press : Restoration of sound.
6	MENU	Access to the main menu to activate/deactivate or choose the adjustments for your vehicle. In certain countries, this control is deactivated while the vehicle is moving.
7	OK	In a menu, a list, an alphabet : Validation of the function, the element or the value chosen. If your vehicle has the Bluetooth system : Answer call, end call
8		Selection of the next or previous elements of a menu in a screen, a list, an alphabet.
9	ESC	Short press : Cancellation of the current operation. Long press : Return to the permanent display.

10	MODE	Selection of type of information displayed on the right of the screen and, for screen A, choice of activation/deactivation of functions and adjustments.
11		If your vehicle has the Bluetooth system : Press : Display of the "Directory" menu.
12		If your vehicle has the Bluetooth system : Press : Activation of voice recognition.

IV

Multifunction screen A

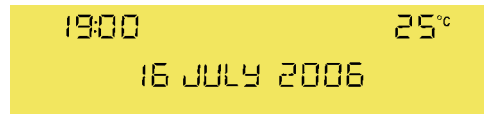

Multifunction screen C



Technical specifications

Your Bluetooth compatible radio possesses :

- 3 wavebands (MW/LW/FM).
- Dual tuner with RDS EON PTY, display of the PS name, RDS programme search, TA traffic information, 24 pre-selections (18 FM - 6 MW/LW), automatic memorisation of the AST strongest stations.
- An MP3- compatible CD reader.
- Audio power of 4 x 35 W.

On / Off

With the key in Drive position **M**, press on control **A** to switch the radio on or off.

Note :

- If the radio was on the last time you switched off the ignition, it will resume automatically when you switch on the ignition again. You will not have to press on control **A**.
- After switching off the ignition, you can still operate the audio system even without the ignition key being present. Simply press on button **A**. The system will turn itself off **after approx. 30 minutes**.

Anti-theft system

This radio is coded in such a way as to function only on your particular vehicle. It would be unusable if installed on any other vehicle.

Note :

The anti-theft system is automatic and requires no action on your part.

Selection of source

To select either Radio, CD (CD already inserted and Radio source activated), or CD changer source, press on control **D**.

When you insert a CD it automatically starts being read.

Note :

When the radio is switched off, the source selected is memorised.

Volume adjustment

Rotate control **A** to increase or decrease the sound volume.

You can also increase or decrease the volume using buttons **1** and **4** at the steering wheel.

Note :

- The sound volume when you switch off the radio will be the same when you switch it on again.
- The radio sound volume automatically adjusts to the vehicle speed, provided the “**volume adjustment**” function is activated.

Temporary sound pause

Press on control **5** at the steering wheel, or on the **MUTE** button, to activate this function.

The sound will be paused, regardless of the source selected.

To restore the audio output, press one of the controls at the steering wheel.

Sound adjustments

Each press on button **F** brings up the parameter to be adjusted : choice of predefined sound ambiences, bass, treble, loudness, fade (front/rear sound distribution), balance (left/right sound distribution) and volume adjusted to vehicle speed.

Press buttons **K** or **N** to modify the values for the function displayed.

Note :

- The selection of a sound ambience automatically adjusts bass and treble. These can be modified. To restore the original adjustments for the musical ambiences, reset bass and treble to zero.
- Adjustment of loudness, as well as bass and treble when they are available, are specific to each sound source and to each musical ambience.
- If you leave the audio system un-actioned for a few seconds, it will revert to the normal display.

Notes on radio reception

Your radio will be subject to certain phenomena that are not encountered by domestic systems.

The reception of AM and FM signals may suffer from interference, which is caused by the nature and propagation of the signals and does not reflect on the quality of your radio installation.

In AM, the reception may be affected when passing under power lines or bridges, or when travelling through tunnels.

In FM mode, the reception may be affected by the distance from the station transmitter, the reflecting of signals off obstacles (mountains, hills, tower blocks) and radio blackspots (no coverage from the station transmitter).

Selection of radio source

Press button **D** to select the source.

Selection of frequencies and memory banks

Press button **E** successively to go through the memory banks FM1, FM2 and FM3, for the FM waveband, and the memory banks MW/LW, for the AM waveband.

Manual search

Manual search is via buttons **J** or **M**.

By keeping button **J** or **M** pressed, you will be able to scroll through the waveband. Scrolling will stop as soon as you release the button. The radio will remain tuned to the frequency that is displayed.

Tuning sensitivity

Automatic searches can be carried out according to two levels of sensitivity :

- To capture the most powerful transmitters, choose the local search mode "**LO**" (default option).
- To capture the weakest or most distant transmitters, choose the sensitive search mode "**DX**".

Search for a station is done first in "**LO**" (local) sensitivity, then in "**DX**" (distant) sensitivity.

To commence a search in sensitivity "**DX**" (distant) immediately , press twice in succession on one of the buttons **K** or **N**.

Automatic search

A short press on one of the buttons **K** or **N** will tune into higher or lower radio stations respectively, within the chosen waveband.

By keeping button **K** or **N** pressed, you will be able to scroll through the waveband. The scrolling will stop at the first station it finds once the button is released.

You can also do this by means of control **2** at the steering wheel.

If the automatic search is unable to tune into a known frequency (perhaps owing to very weak reception), it is possible to search manually to find this station.

Display and selection of a station available in the area in which you are travelling

Briefly press on button **G** to bring up a list of stations, this is updated every **10** minutes.

You can also update this list at any time by giving a long press on button **G**.

To listen to one of these stations, select by pressing buttons **J** or **M** and validate using button **L**.

Manual pre-setting

Select the waveband and memory bank required using button **E**.

Select a station using either automatic or manual search.

Keep pressing for more than two seconds on one of the pre-selection buttons **1** to **6** on the keypad **P**.

The sound momentarily cuts off, then returns to its previous level to confirm that it has memorised the station.

Automatic memorisation of transmitters (Autostore function)

In FM, if you hold down button **E** for more than two seconds, your radio will automatically memorise the 6 strongest stations on the FM3 memory bank.

The display shows "**FM AST**".

The radio memorises the 6 strongest transmitters, deleting the 6 previously memorised.

After the memorisation, the radio goes directly to memory 1 of memory bank FM3.

Note :

- If the traffic information function has been activated (see RDS SYSTEM), the stations offering this facility will be memorised as priority.
- If it is unable to memorise any new stations, the system will retain the previously memorised stations.
- If the system is unable to find 6 stations, the unfilled memory slots will remain free.

Recall of pre-set stations

Press button **E** briefly to select the required waveband and memory bank.

A short press on one of the pre-selection buttons **1** to **6** on the keypad **P** recalls the corresponding memorised station. You can also do this using the control **3** at the steering wheel.

If it is a RDS station, the frequency appears some seconds before the name appears.

For RDS stations, recall of a station may prompt a search for a frequency corresponding to the region where you happen to be (see RDS system).

Using the RDS (radio data system) function on FM

The majority of FM radio stations use the RDS system. The radio in your vehicle has this system,.

The RDS system enables these stations to transmit non-audible data in addition to the broadcasting of their programmes. The data provides access to various functions described in this chapter, such as: display of the station name, intermittent traffic information flashes or automatic scanning of stations. This enables you to continue listening to your chosen radio station, regardless of the different frequencies it uses in the regions through which you are travelling.

Scanning of RDS stations

Your radio keeps the best possible reception by continuously looking for any other frequencies on which the selected radio station is broadcast, automatically choosing the frequency offering the best reception (providing the station broadcasts on more than one transmitter or frequency).

Activation/deactivation of the RDS functions

The RDS functions can be accessed via the following two menus :

- **Main menu** (press button **O**).
- **Audio menu** (press button **L**).

To activate/deactivate the RDS functions on multifunction screen C :

1. Press button **O**.
2. Select the AUDIO icon using buttons **J** or **M**.
3. Confirm your choice with a press on button **L**.
4. Select the sub-menu for the FM waveband, via buttons **J** or **M**. Confirm your choice with a press on button **L**.
5. Select scanning for RDS stations, via buttons **J** or **M**.
6. Validate your choice with a press on button **L**.
7. Using control **L**, select/deselect to activate/deactivate the function.
8. Validate your choice by selecting "**OK**" on the display.

To activate/deactivate the RDS functions on multifunction screen A :

1. Press button **O**.
2. Select the AUDIO-CD icon via buttons **J** or **M**.
3. Select scanning for RDS stations, via buttons **J** or **M**. The system tells you the status (active or inactive) of the function.
4. Modify this status via buttons **K** or **N**.
5. Then please wait for the display to disappear.

Note :

If the RDS function is active :

The "**RDS**" on the display will light up provided the station being received uses the RDS system with scanning of frequencies.

The "**RDS**" on the display is barred if the station received uses the RDS system without frequency search.

If your RDS function is deactivated, the "**RDS**" on the display will be absent in all cases.

The display will indicate the "**NAME**" for the stations that use the RDS system and the frequency for stations that do not use it.

Regional search mode

Some stations, when they are organised in networks, broadcast regional programmes at certain times of day, and national programmes at other times.

It is possible to search :

- Either for a regional station only.
- Or across the whole network in order to find a different programme.

To activate/deactivate this function, proceed as for Scanning of RDS stations.

Note :

When this mode is activated, the system will remain tuned to one specific regional station.

TA traffic information (traffic announcements)

Some stations allow broadcasting, only in FM, of these messages thanks to the “TA” function.

You can activate the “TA” function by pressing on button **I**. This allows you, even though you are listening to another audio source or to a radio programme not itself providing traffic messages, to receive traffic information flashes from an FM station which broadcasts them.

While the messages are being broadcast the original source is paused and when the messages have ended your radio will automatically revert to the music programme you were listening to.

Notes :

- You have to be in FM wave band.
- The station being listened to should indicate via the RDS system that it broadcasts traffic information.
- Stations organised in a network (EON) have regional transmitters that send their own programmes: while you are listening to one of these stations the system will switch automatically to a station on the network that is broadcasting traffic information.
- You can stop listening to a message by pressing button **I**.

Sound volume adjustment for traffic information

The sound volume for traffic information operates separately from that for the rest of the system, and can be adjusted independently.

Rotate button **A** while a traffic information message is being broadcast.

This volume adjustment is memorised.

Selecting a programme type

Certain stations offer the possibility of listening to a particular programme type, selected from a list (PTY).

press for more than two seconds on button **I**.

Press on buttons **J** or **M** to scroll through and select the programme type you prefer, then press on button **L** to validate your choice.

Searching for a station broadcasting this programme type

When you have chosen a programme type, the list of corresponding stations appears on the display, press on buttons **J** or **M** to scroll down and select the station you want, then press on button **L** to validate your choice.

Quitting pty mode

To quit “PTY” mode, select the function to deactivate “PTY” in the list of the different programme types.

Radio text via contextual menu

This function allows to view the information broadcast by the station, concerning the programme you are currently listening to.

To activate/deactivate this function, proceed as for Scanning of RDS stations.

Selecting CD source

After inserting a CD, with the printed side facing upwards, the player will start playing the CD automatically.

To change manually to CD source (CD already inserted), press button **D** until you obtain the source you require.

Ejecting a CD

Press button **B** to eject the CD, the audio system will automatically switch to radio source.

If the CD is not removed within 10 to 15 seconds of being ejected, it will automatically be taken back into the CD player, although it will not be played.

Selecting a track

Press button **K** once to play the next track.

Press button **N** once to return to the beginning of the track currently being played, press a second time to go back to the start of the previous track.

Press the buttons successively to skip several tracks at a time.

This can also be done via the control **G**. As the list of tracks is displayed on the screen, select the desired track using buttons **J** or **M**, then validate using button **L**.

You can also do this by means of control **2** at the steering wheel.

Fast forward and rapid reverse with accelerated sound

To move swiftly through the CD, press and keep pressed button **K** or **N**, respectively for fast forward or rapid reverse with accelerated sound.

Play resumes as normal when the button is released.

Menu

This menu allows activation/deactivation of two options :

- Playback of the first 7 seconds (approx.) of each track of the CD.
- Random playback of the CD tracks.

This can be accessed in two ways :

- Either by pressing button **O** and proceeding as for Search of Stations RDS – for screen C, the sub-menu corresponds to the Audio Preferences.
- Or, provided you are in CD source, by pressing on button **L**. You can then access the Audio menu (for screen C only).

Note :

If one of these options is active, it remains active for CD changer source.

Safety precautions

For safety, do not use a CD player if the cabin temperature is higher than +60 °C or lower than -10° C.

If the temperature becomes too high, an automatic safety device will prevent the CD player from working until an acceptable temperature is restored.

Handling compact discs

Do not drop them. Store the CDs so that they are kept of dust. Avoid touching the disc surface as any scratches may adversely affect the sound quality. Do not attach any stickers to the discs. Do not use damaged or deformed discs. Do not expose them to heat or direct sunlight.

If the surface of the compact disc is dirty, it can be wiped with a soft, clean cloth. Always wipe from the centre of the disc outwards.

MP3 CD player

Your Audio CD system may be MP3 compatible.

As you insert a CD recorded in MP3 format, playback starts of the first song of the first CD-cover.

You can select a particular track by using buttons **N** or **K** and CD-covers using buttons **J** or **M**.

To select a track

To display the list of CD-covers, press on button **G**.

Use buttons **J** or **M** to select the CD-cover you wish to listen to.

To open a CD-cover, press **L**.

Use buttons **N** or **K** to select the track you wish to listen to.

Validate by pressing button **L** or control **7** at the steering wheel.

Menu

This menu is for activation/deactivation of three options :

- Playback of the first 7 seconds (approx.) of each track of the CD.
- Repetition of the current CD-cover.
- Random playback of CD-cover tracks by CD-cover.

This can be accessed in two ways :

- Either by pressing button **O** and proceeding as for Search of Stations RDS – for screen C, the sub-menu corresponds to the Audio Preferences.
- Or, provided you are in CD source, by pressing on button **L**. You can then access the Audio menu (for screen C only).

CD Changer

This equipment **S** (if present) is located in the passenger's storage compartment on the dashboard. It can accommodate 5 discs.

Inserting CDs into the magazine

Insert the CDs printed surface to the left.

Note :

- Each compartment takes one disc only.
- The CD changer will not operate if discs are inserted the wrong way up.

Removing discs

To remove a CD, give a long press on the corresponding button.

Note :

- The CD changer (if there is one) is not MP3 compatible.

Selecting CD changer source

Press on button **D** until you reach CD changer.

After the magazine engages, playback of the first track of the first CD will begin.

Selecting a CD

To select a CD, either press one of the pre-selection buttons **1** to **5** on the keypad **P**, or scroll using buttons **J** or **M**.

The CD will start to play automatically.

You can also do this by means of control **3** at the steering wheel.

After each change of source, on return to CD changer source, playback will resume at the same point where it had been interrupted.

Selecting a track

Press button **K** once to play the next track.

Press button **N** once to return to the beginning of the track currently being played, press a second time to go back to the start of the previous track.

Press the buttons successively to skip several tracks at a time.

You can also do this by means of the controls **2** and **3** at the steering wheel.

Fast forward and rapid reverse with accelerated sound

Press and keep pressed one of the buttons **K** or **N** respectively for fast forward or rapid reverse with accelerated sound. Play resumes as normal when the button is released.

Menu

This menu is for activation/deactivation of three options :

- Playback of the first 7 seconds (approx.) of each track of the CD.
- Repetition of the current CD.
- Random playback of tracks, CD by CD.

This can be accessed in two ways :

- Either by pressing button **O** and proceeding as for Search of Stations RDS – for screen C, the sub-menu corresponds to the Audio Preferences.
- Or if you are in CD changer source by pressing button **L**. You then have access to the AUDIO menu (for screen C only).

Note :

If one of these options is active, it remains active for CD source.

Your audio system may be Bluetooth compatible. It allows you to connect a **mobile telephone** for use “**hands free**” and even to use its directory.

It permits you to twin up to four telephones, to be able then to connect whichever one you choose.

The Bluetooth functions available and the content of the display are dependent on the type of mobile telephone, its settings and the type of contract you have. For this reason it is advisable to make enquiries with your telephone provider.

Prior to any operation :

Your display should be lit up (key in position **M**).

Your telephone's Bluetooth system must be activated.

Twinning a telephone

Twinning a telephone consists of having it recognised by the Bluetooth system on your vehicle. This then permits an instantaneous connection.

Twinning can only be performed with **ignition switched on, display illuminated, engine stopped**. No other telephone should be connected.

The twinning must be performed with the telephone and its Bluetooth system activated.

Notes :

Refer to the user instructions to familiarise yourself with the features of twinning.

- The telephone detects the Bluetooth system on your vehicle. “**CITROËN**” displays on your telephone.

You should then select “**CITROËN**” on your telephone controls. Next you must choose whether or not to accept this twinning then select, on screen **C** using **J**, **M** or **8**, one of the **4** memories. Validate with a press on button **L** or **7**.

Note :

You can select a memory already attributed, although the telephone twinned to this location will no longer be.

- Next the telephone asks you to enter an identification code : **1234**.
- Validate.

Notes :

This entry may be demanded earlier in the twinning sequence.

The telephone is now twinned to your Bluetooth system. For immediate access to the Bluetooth functions, it may be necessary to make a connection (see following page, **Configuration : Connecting a twinned mobile telephone**).

Once the twinning is finished, you will be able to connect your telephone via the “**Main menu**”.

Connecting a twinned telephone

Each time you enter the vehicle, after switching on the audio system, your telephone is detected

automatically. If more than one telephone is present, the last telephone to have been connected is the first to be recognised.

Note :

Disconnections may occur. You may have to make a new connection (see following page, **Configuration : Connecting a twinned mobile telephone**).

Observations :

- In the event of a problem, it is recommended to switch your telephone off and then on again.
- If you switch off your telephone within the field of reception of the Bluetooth system on your vehicle, the next connection will not be automatic. To restore automatic connection, you will have to connect your telephone manually (see following page, **Configuration : Connecting a twinned mobile telephone**).
- If you are already in telephone communication when the audio system is turned on, the latter detects the telephone.
- To avoid interference, you are advised not to place your mobile telephone close to your radio.

To accept an incoming call

Use button **L** or control **7** at the steering wheel.

Main Menu

Press on the Menu control **O** to access the Main Menu, then select the “**Telephone**” icon via buttons **J**, **M** or **8** and then validate the selection via button **L** or **7**.

You have access :

- To the Directory.
- To Configuration.
- To Communication Management.

You access your choices using **J**, **M** or **8** then you validate them with a press on **L** or **7**.

This main menu can also be accessed by pressing button **E** then button **L**.

Directory

This menu lets you open :

The telephone Directory of the telephone that is connected.

The Calls List.

This menu can also be accessed with a press on control **11**.

Telephone directory

The starting of a telephone call can be done independently of the telephone or of the audio system, thanks to the directory.

The directory is displayed. Select the number via **J**, **M** or **8**, then validate with a press on **L** or **7**.

Observations :

The directory displayed updates itself automatically.

If the person to be called does not figure in the directory, the call can only be made starting from the telephone.

If you have information recorded in the Vcard format, you must select the person you wish to call, then validate. A list of 4 numbers maximum can be displayed with the following labels : “**Home**”, “**Office**”, “**Mobile**” and “**Car**”.

Calls list

After selecting this component and then validating, the calls list is displayed with a maximum of : **10** calls made (arrow pointing upward), **10** calls received (arrow pointing downward) and **10** calls not connected.

It is possible to make a call starting from this list : Select the number via **J**, **M** or **8**, then validate with a press on **L** or **7**.

Configuration

This menu allows you to :

- Delete a twinning.

Using **J**, **M** or **8**, select this choice then validate via **L** or **7**. Select in the list the telephone that you no longer wish to have twinned. Validate.

- Consult the list of twinings.

The list of telephones twinned is displayed.

- Connect a mobile telephone that is twinned.

Select the telephone that you wish to connect. This access allows you to make a connection manually.

Call management

This menu is accessible during your calls, permitting you to :

- Swap a call if there is another call incoming.
- End a call.
- Be in Secret mode.

Note :

If you are in telephone conversation, you have access to this “**Configuration**” menu by means of a press on **L** or **7**.

To swap a call

During a telephone conversation, the system is able to tell you of a second call incoming. To accept it, validate. To change from one call to the other, select this choice.

To end a call

This choice enables you to end a telephone conversation, for example if there is another call incoming.

Secret mode

Select this choice. This allows you not to be heard by the other person. To restore sound to the other person, select deactivation of Secret mode in the menu “**Call Management**”.

Note :

If you wish to transfer a call from the audio system to the mobile telephone (for example when leaving your vehicle), refer to the user instructions for the latter.

Voice recognition

A short press on button **12** starts voice recognition for the telephone.

Voice recognition allows you to make a call to a number for which you have recorded a label on the mobile telephone that is twinned and connected.

Note :

It is possible to stop the call as long as the dialling has not commenced, by means of a short press on button **12**.

Notes :

- While you are on a call, the audio source currently being listened to is paused.
- Some ring tones on your mobile telephone may not be recognised by the Bluetooth system on your vehicle. A different ring tone will be chosen by the system.

Displays

A press on the “**TEL**” button displays the telephone information on the right on your screen.

A “**Telephone**” symbol appears on your display when you connect a mobile telephone.

A “**Battery**” symbol appears at the bottom of the display to indicate the range of the mobile telephone connected.

An “**Envelope**” symbol appears at the bottom of the display to indicate the presence of an unread SMS on the mobile telephone connected.

A “**Sound track**” symbol appears at the bottom of the display to indicate the presence of a message on the mobile telephone connected.

Your vehicle may be equipped with a Philips Hi-Fi system, specially designed to fit in with your cabin interior.

It consists of :

- A DSP (Digital Signal Processing) high power digital amplifier,
- A low subwoofer box (30Hz – 100 Hz),
- 8 Philips-specific loudspeakers,
- an MP3 reader.

Adjustment in CD or radio mode

The basic functions remain the same as those for the radio.

No extra adjustment is necessary.

However, to profit fully from your Philips system, you are recommended to adjust the audio functions: bass (Bass), treble (Treb), front/rear balance (Fad), left/right balance (Bal) to position **O**, Loudness (Loud) to position **ON** for listening to a CD and to position **OFF** for listening to the radio.

Your system also gives you Dolby wrap-around sound for Pop, Rock and Classical.

Note : In the event of poor reception of the FM stereo signal and/or the mono source, deactivate the sound ambiances.



Refuelling

1. Press on the the control **A** situated on the control panel on the left hand side. The fuel flap automatically opens up.
2. Take care to select the pump that corresponds to the correct fuel type for your vehicle.
3. Introduce the nozzle so as to push in the metallic gate valve **B**.
4. Make sure that the nozzle is pushed in as far as possible before starting to refuel (risk of blowback).
5. Maintain this position throughout the refuelling operation.
6. Push the fuel flap to reclose it.



For petrol engines, unleaded fuel is obligatory.

The filler neck is narrower, permitting unleaded petrol only.

If you are filling your tank to the top, do not persist after the third cut-off ; that could cause your vehicle to malfunction.

FUEL QUALITY

A label affixed to the inside of the fuel flap indicates the fuels that are authorised.



UNLEADED PETROL

DIESEL

DIESEL FUEL

The petrol engines are designed to run on RON 95.

However, for better vehicle performance (petrol engines), we recommend RON 98.



After switching off the ignition, the control **A** is active for only a few minutes. If necessary, switch on the ignition again to reactivate it.

If you have put in fuel that is wrong for your vehicle, it is essential to have the tank drained before you start the engine.

BONNET RELEASE

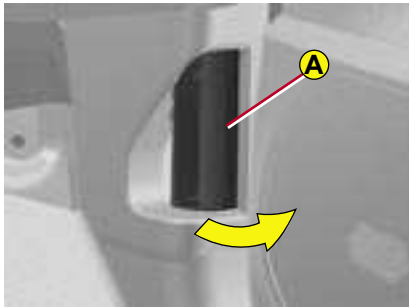

This operation should only be performed when the vehicle is stationary.

To unlock the bonnet, pull towards you the control **A** located under the dashboard.

Note : the driver's door has to be open for you to be able to action the control.

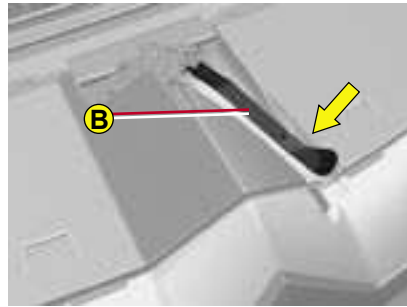

Move the lever **B**, located at the top of the grille to the right of the chevrons, then raise the bonnet.



Bonnet stay : detach the stay **C** and pivot it upwards to insert it into the notch.

To close the bonnet

Move the stay **C** back to its initial position, lower the bonnet and then allow it to slam shut.

V

**Check that the bonnet is locked.
Avoid opening the bonnet in high winds.**

1.8i 16V ENGINE - 2.0i 16V ENGINE

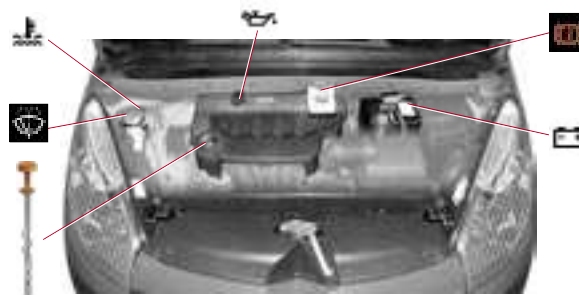

V

1.6 HDi 110 ENGINE

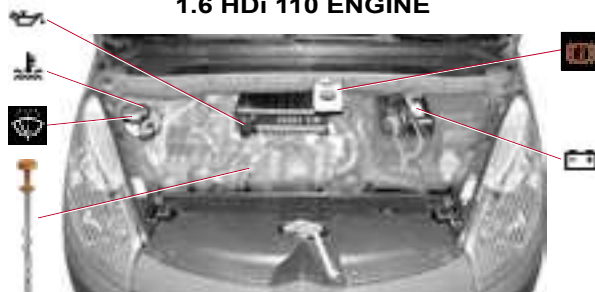

2.0 HDi 138 ENGINE

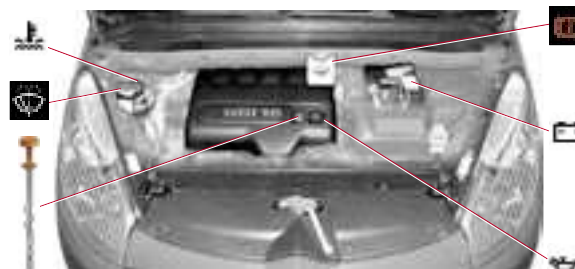

Due to the fact that the diesel fuel system is a high pressure system :
IT IS FORBIDDEN TO CARRY OUT ANY REPAIRS TO THE SYSTEM.

**HDi engines are of a highly technical nature.
All maintenance and repairs require specific qualifications which only a
CITROËN dealer can guarantee.**

LEVELS - CONSULT THE CHAPTER "USER PRECAUTIONS"

Air filter

Follow the instructions given in the Maintenance Guide.



Wash fluid for windscreen, rear screen and headlamps

Use only those products that are approved by CITROËN.

Capacity : see «Capacities»



Engine coolant

The coolant level should be between the **MIN.** and **MAX.** marks on the expansion chamber.

If the engine is hot, wait 15 minutes for it to cool down.

Quality : See the Maintenance Guide.

Never intervene on the cooling system of an engine that is hot (See «Levels»).



Engine oil

Check the oil level with the vehicle parked on horizontal ground, with the engine having been switched off for at least 15 minutes.

Quality : See the Maintenance Guide.



Pull out the manual dipstick.

The level should be between the **MIN.** and **MAX.** marks on the gauge.

It must never exceed the maximum.

MAX.
MIN.



12V battery

See « Emergency starting with a slave battery ».



Brake fluid

The brake fluid level should be between the **MIN.** and **MAX.** marks on the reservoir.

Quality : See the Maintenance Guide.

Should the warning lamp come on while you are driving, stop immediately and contact a CITROËN dealer.



If intervening under the bonnet when the engine is hot, even when the vehicle is stationary and the ignition switched off, be aware that the cooling fan could operate at any time.

Check the engine oil level frequently between each routine service visit, as well as before starting long journeys.

V



V



Radiator - coolant fluid

Checking the level and topping-up with coolant should always be done with the engine cold.

Engine hot

Wait fifteen minutes or for the engine temperature to fall below 100°C, then slowly undo the cap to allow the pressure to drop, protecting yourself with a cloth for example.

The coolant level should be between the **MIN.** and **MAX.** marks on the expansion chamber.

Top up the level. If you have to add more than 1 litre, have the cooling system checked by a CITROËN dealer.

Ensure that the cap is securely on.

Note : The need to top up frequently indicates a malfunction which should be checked out as soon as possible.

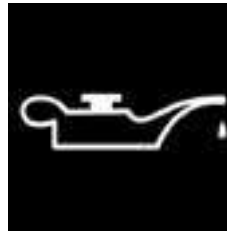

Topping up the engine oil

Take out the dipstick before filling. Check the level after filling.

The maximum mark must never be exceeded.

Do up the cap before closing the bonnet.

Quality : See the Maintenance Guide.

Note : for vehicles with a particle filter, the cooling fan can operate as long as ten minutes after the engine has stopped.



Screen wash fluid

It is essential to have sufficient wash fluid, particularly if your vehicle has Xenon dual-function directional headlamps.

Capacity : See «Capacities».



If intervening under the bonnet when the engine is hot, even when the vehicle is stationary and the ignition switched off, be aware that the cooling fan could operate at any time.

DIESEL INJECTION EQUIPMENT

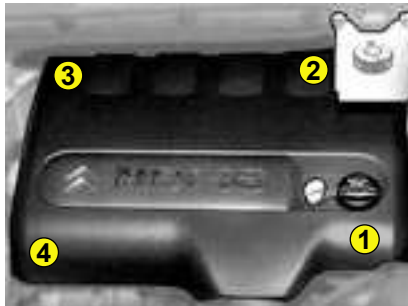

Protection cover

HDi 138 engine

Remove the protection cover by first unclipping point **1**, then **3** and **4**. Detach point **2** by pulling towards you, then lift.

To reposition the protection cover, attach point **2** first. Lower the cover, keeping it centred. Clip points **1** and **4**, pushing vertically and slightly rearwards. Clip point **3** pushing down vertically.



Draining water from the fuel filter

Bleed on a regular basis (at every oil change).

To evacuate the water, slacken the bleed screw or the water-in-diesel-fuel sensor, which is located at the base of the filter.

Persist until water ceases to flow out.

Then retighten the bleed screw or the water-in-diesel-fuel sensor.

V

**HDi engines are of a highly technical nature.
All maintenance and repairs require specific qualifications which only your CITROËN Dealer can guarantee.**

DIESEL INJECTION EQUIPMENT

V



HDi 138 engine

Detach the protection cover to gain access to the priming pump.



HDi 110 engine

Detach the protection cover to gain access to the priming pump.

Priming the circuit

In the event of running out of fuel :

- After filling (minimum 5 litres), action the manual priming pump, until some resistance is felt.
- Then action the starter, gently pressing the accelerator until the engine starts.

If the engine fails to start at the first attempt, wait 15 seconds before trying again.

If the engine fails to start after a few attempts, repeat the procedure from the beginning. When the engine is idling, accelerate gently to complete the purge of the circuit.

HDi engines are of a highly technical nature.

All maintenance and repairs require specific qualifications which only your CITROËN Dealer can guarantee.

CAPACITIES

Fluid for screen wash	3 litres
Fluid for screen wash and headlamp wash	6 litres

Engine type	Engine oil capacities (in litres)⁽¹⁾
1.8i 16V - 92kW	5.00
2.0i 16V 105 kW (143hp)	5.00
HDI 110 (80kW)	3.75
HDI 138 (100kW)	5.25

V

(1) After oil change with oil filter change

BATTERY

Emergency starting with a slave battery

A vehicle with a discharged battery can be started with either a slave battery or the battery of another vehicle.

- A** Discharged battery on broken-down vehicle (under the bonnet).
- B** Slave battery.
- C** Earth point on broken-down vehicle.

Check that the emergency battery is correctly charged up (12 volts).

If you are using the battery on another vehicle, stop the engine of the assisting vehicle. The two vehicles must not come into direct contact with each other.

Connect the cables in the **order** indicated in the diagram. Make sure that the clamps are properly secured (risk of sparks).

Start the engine of the assisting vehicle. Let the engine run for about a minute at a slightly accelerated speed.

Start the engine of the assisted vehicle.

Note : For any operation necessitating a disconnection of the battery, you should wait three minutes after switching off the ignition, without taking any action which would prevent the vehicle's electrical circuit from going to sleep (such as operating the doors and tailgate or the remote control, etc.).

After a disconnection and reconnection of the battery, when you switch on the ignition, wait for approximately one minute before operating the starter motor in order to allow the electronic systems to reinitialise. Following a prolonged disconnection of the battery, it may be necessary to reinitialise the parameters of the multifunction display (date, time, language, units of distance and of temperature).



V



Advice

Do not touch the cable clamps during the procedure.

Do not lean over the batteries.

Disconnect the cables in the reverse order to connection, ensuring that they do not touch each other.



Never apply a flame or create sparks close to the battery (explosive gas).

The battery contains diluted sulphuric acid which is highly corrosive.

If ever you are handling the battery, protect your eyes and face.

In the event of any contact with the skin, rinse immediately with copious amounts of fresh water.

For any battery replacement, contact a CITROËN dealer.

FUSES

Fuseboxes

There are two fuseboxes in the glovebox, one fusebox in the engine compartment and another fusebox on the battery.

Changing a fuse

Before replacing a fuse, it is essential to find the cause of the incident and to have it rectified. The fuse identification numbers are indicated inside the fusebox.

Replace a blown fuse with one of the same rating (the same colour)

Use the special tool **A** that is provided in the fuse housing flap, which also contains spare fuses.



Access to the first glovebox fusebox

V

Correct



Incorrect

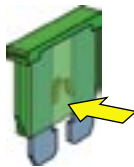

Tool A

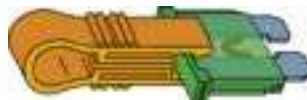

Fuses in the glovebox

After any operation on the fuses in the fusebox, check that the fusebox cover is put back correctly for their protection.

TABLE OF FUSES - FUSES UNDER THE DASHBOARD

Reference	Rating	Functions
F1	15A	Rear screen wipe
F2	30A	Locking and unlocking earth
F3	5A	Airbag
F4	10A	Multimedia, photochromic rear view mirror, particle filter, diagnostic socket, air conditioning, headlamp height correction control
F5	30A	Front windows, front door electronics, panoramic glass roof
F6	30A	Rear windows
F7	5A	Interior lamps, refrigerated glovebox, radio
F8	20A	Multifunction display, radio, CD changer, steering wheel controls, multimedia, deflation detection, alarm, trailer
F9	30A	Cigar lighter, multimedia, front 12V socket, torch, radio
F10	15A	Height corrector (suspension)
F11	15A	Brake switch, ignition switch
F12	15A	Parking assistance, automatic screen wipe and lighting, passenger's electric seat, AFIL, Hi-Fi amplifier, trailer
F13	5A	Engine relay unit, driver's electric seat
F14	15A	Air conditioning, Bluetooth® hands-free kit, automatic gearbox selector, airbag, instrument panel
F15	30A	Locking and unlocking
F16	SHUNT	
F17	40A	Heated rear screen

V

TABLE OF FUSES - FUSES UNDER THE DASHBOARD



Access to the second glovebox fusebox

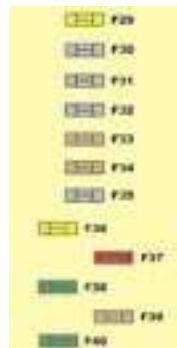

V

Reference	Rating	Functions
F29	20A	Heated seats
F30	Free	
F31	Free	
F32	Free	
F33	5A	Parking assistance, automatic screen wipe and lighting, passenger's electric seat, AFIL, Hi-Fi amplifier
F34	5A	Trailer
F35	Free	
F36	20A	Hi-Fi amplifier
F37	10A	Air conditioning, light pack
F38	30A	Driver's electric seat
F39	5A	Fuel flap
F40	30A	Passenger's electric seat, panoramic roof

TABLE OF FUSES - FUSES UNDER THE BONNET



V

Engine compartment fuses

Fusebox

To access the fusebox located in the engine compartment, detach and remove the cover.

After any operation, carefully reclose the cover. If the cover is not correctly positioned or not properly closed, that could cause serious problems on your vehicle. For the same reason, take care not to spill any liquid in the fusebox.

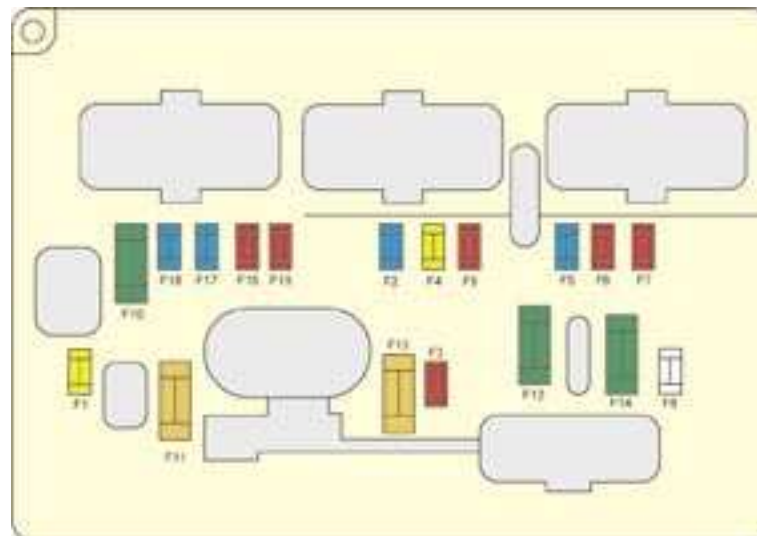

All work on the MAXI fuses, which are located in these fuseboxes and which give extra protection, is the preserve of CITROËN technicians.

TABLE OF FUSES - FUSES UNDER THE BONNET

Reference	Rating	Functions
F1	20A	Engine management
F2	15A	Horn
F3	10A	Screen wash pump
F4	20A	Headlamp wash pump
F5	15A	Engine components
F6	10A	Xenon dual-function directional headlamps, headlamp height correction motor, clutch switch, BCP (protection switch box)
F7	10A	Automatic gearbox, engine coolant level switch, power steering
F8	25A	Starter motor
F9	10A	Stoplamp switch
F10	30A	Engine components
F11	40A	Rear blower
F12	30A	Screen wipe
F13	40A	BSI (Built-in Systems Interface)
F14	30A	Air pump, heat exchange saver
F15	10A	Right-hand main beam
F16	10A	Left-hand main beam
F17	15A	Left-hand dipped beam
F18	15A	Right-hand dipped beam

V

TABLE OF FUSES - FUSES ON THE BATTERY



After any operation, carefully reclose the cover. If the cover is not correctly positioned or not properly closed, that could cause serious problems on your vehicle. For the same reason, take care not to spill any liquid in the fusebox.

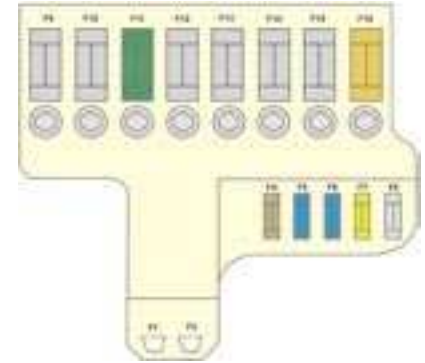

V

Fuses on the battery

Fusebox

To access the fusebox located on the battery, detach and remove the cover.

Reference	Rating	Functions
F1		Battery Plus connection studs
F2		Supply connection studs, BSM (engine relay unit)
F3		
F4	5A	Automatic gearbox actuator and ECU
F5	15A	Diagnostic socket
F6	15A	ECU for 6-speed electronic gearbox / automatic gearbox
F7	5A	ESP ECU
F8	20A	Rear 12V socket

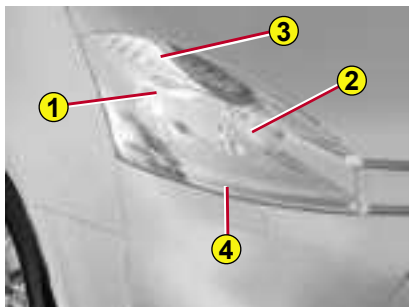

FRONT LENS

- ❶ Dipped beam
- ❷ Main beam
- ❸ Sidelamp
- ❹ Direction indicator

Note : A slight misting may appear on the surface of the headlamp glass in certain conditions of use.



Dipped beam

1. Remove the rubber plug.
2. Rotate the bulb-holder a quarter turn anti-clockwise and remove it from its housing.
3. Replace the bulb H7.
4. Reposition the bulb-holder by pushing it in, tightening it by a quarter turn (clockwise).
5. Put back the rubber plug.

VI



Changing a halogen bulb should only be done after the headlamp has been switched off for a few minutes (risk of serious burn).

Do not touch the bulb directly with your fingers, use lint-free cloths.

It is imperative to use only anti-U.V. type bulbs in order not to damage the headlamp.



VI

Main beam

1. Remove the rubber plug.
2. Detach the clips by lowering them on each side of the bulb.
3. Pull on the bulb-holder to remove it.
4. Replace the bulb H1.
5. Push the bulb-holder back into its housing.
6. Reattach the clips.
7. Put back the rubber plug.

Sidelamp

1. Rotate the bulb-holder a quarter turn anti-clockwise.
2. Remove it from its housing.
3. Replace the bulb H6W.
4. Reposition the bulb-holder.
5. Rotate it a quarter turn clockwise to reposition in its housing.

Direction indicator

1. The direction indicator bulb is located underneath the main beam bulb. Remove the rubber plug.
2. Pull on the bulb-holder to remove it.
3. Replace the bulb H21.
4. Reposition the bulb-holder in the bracket and push it in.
5. Put back the rubber plug.

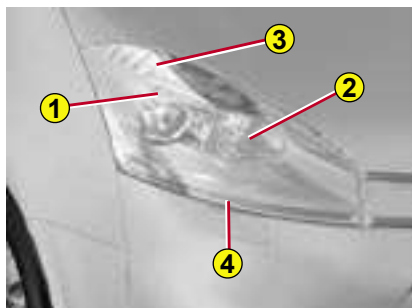

FRONT LENS WITH XENON DUAL-FUNCTION DIRECTIONAL HEADLAMPS

❶ Xenon dual-function headlamp (dipped/main beam)



If the headlamp bears this symbol, any operation to change the Xenon dual-function directional headlamp D1S is the preserve of professionals (risk of electrocution).

Contact a CITROËN dealer.

It is recommended to change both bulbs at the same time if one of them is faulty.

❷ Main beam (H7)

1. Remove the rubber plug.
2. Rotate the bulb-holder a quarter turn anti-clockwise and remove it from its housing.
3. Replace the bulb H7.
4. Reposition the bulb-holder by pushing it in, tightening it by a quarter turn (clockwise).
5. Put back the rubber plug.

❸ Sidelamp (see « Halogen headlamps »)

❹ Direction indicator (see « Halogen headlamps »)



VI

REAR LENS

Note the bulb that is faulty.

Bulbs

- ❶ **Direction indicator:** PY21W.
- ❷ **Stoptail and sidelamp :** P21/5W.
- ❸ **Reversing lamp :** P21W.

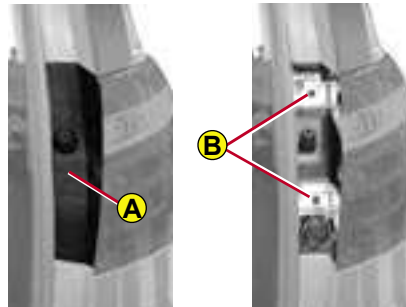

Rear lamp units on the bodywork

1. With the tailgate open, press on the plastic cover **A**, located close to the lens, to release it from its housing.
2. Undo the two screws **B** on the side of the lens and detach the lamp by pulling it rearwards.
3. Disconnect the connector linking the lens unit with the tailgate.
4. Remove the bulb-holder.
5. Replace the bulbs. To remove a bulb, rotate it a quarter turn. To refit the bulb, rotate it a quarter turn in the other direction.
6. Reposition the bulb-holder.
7. Reconnect the connector to the lens unit.
8. Reattach the lamp unit on the bodywork and do up the two screws.
9. Reposition the plastic cover by exerting a pressure.



Rear lamps on the tailgate

1. With the boot open, remove the plastic cover on the tailgate.
2. Remove the bulb-holder from its housing.
3. Replace the bulb. To remove a bulb, rotate it a quarter turn. To refit the bulb, rotate it a quarter turn in the other direction.
4. Reposition the bulb-holder.
5. Refit the plastic cover.

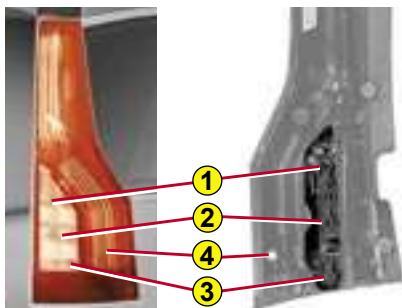

REAR LENS

Note the bulb that is faulty.

Bulbs :

- ❶ **Direction indicator** : PY21W.
- ❷ **Stoplamp** : P21W.
- ❸ **Reversing lamp** : P21W.
- ❹ **Sidelamp** : LED

Contact a CITROËN dealer.

Rear lamps

1. With the tailgate open, undo the 3 screws located on the side of the lens unit and pull it rearwards to detach.
2. Disconnect the connector linking the lens unit to the boot. Do not disconnect the LEDs.
3. Remove the seal.
4. Remove the bulb-holder.
5. Replace the bulbs. To remove a bulb, rotate it a quarter turn. To fit the bulb, rotate it a quarter turn in the other direction.
6. Reposition the bulb-holder.
7. Put back the seal.
8. Reconnect the connector to the lens unit.
9. Stow the harness in the opening provided in the bodywork.
10. Reattach the lens unit on the bodywork and do up the 3 screws.

Third stoplampwith bulb

1. With the boot open, detach the interior trim.
2. Undo the nuts.
3. Using a thin screwdriver, detach the 3 retaining lugs.
4. Remove the lamp via the exterior of the tailgate.
5. Remove the bulb-holder.
6. Change the faulty bulb(s).

Third stoplampwith LED



Contact a CITROËN dealer

VI

Check that the vehicle lamps work correctly after each operation.

CHANGING BULBS



VI Number plate lamp

1. Insert a thin screwdriver in one of the holes on the outside of the plastic cover.
2. Push outwards.
3. Remove the plastic cover.
4. Pull on the bulb to remove it.
5. Replace the faulty bulb W5W.



Foglamp

1. Pass your hand underneath the bumper to reach the bulb-holder.
2. Rotate the bulb-holder a quarter turn.
3. Pull on the bulb-holder.
4. Rotate the bulb a quarter turn to remove it.
5. Replace the bulb P21W.
6. Fit the bulb.
7. Reposition the bulb-holder by rotating it a quarter turn.

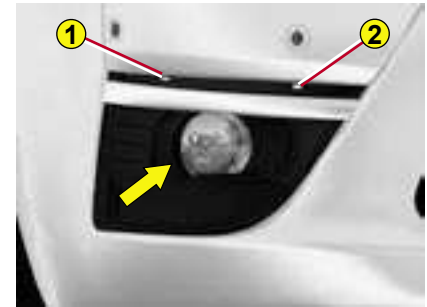

Front foglamps

1. Insert the key in the notch 1, tilting the bulb-holder cover located underneath the bumper, then insert the key in the notch 2 to remove it.
2. Undo the lens.
3. Tilt the bulb-holder.
4. Change the bulb H11.
5. Reposition the bulb-holder.
6. Do up the lens and refit the bulb-holder cover firmly in place.

CHANGING BULBS



Direction indicators side repeaters in the rear view mirrors

To change the side repeater, press firmly downwards on the zone indicated by the arrow, then pull out the side repeater bulb.



Interior lamp (1)

Detach the cover of the interior lamp **1** with a thin screwdriver close to the button, to access the bulb.

Bulb : W 5 W

Spotlamps (2)

Detach the cover of the interior lamp. To access the bulb, detach the partition for the spotlamp concerned, as necessary.

Bulb: W 5 W



Boot lamps

Detach the unit by pushing it rearwards.

Bulb: W 5 W



Torch

1. Open the tab.
2. Push with a flat screwdriver in the hole under the tab and re-cover the bulb unit.
3. Open the bulb unit fully to change the bulb.

Bulb: Krypton 3.6V.

Towbar

We recommend you to have this device fitted by a CITROËN dealer, who will be acquainted with your vehicle's towing capability and with the procedures necessary for installing a safety item of this kind.

It is essential to install a CITROËN approved electronic unit when having a towbar fitted, in order to prevent any risk of malfunction or damage (risk of fire).

The fitting of a caravan mirror on the wing is prohibited.

VI

DIMENSIONS (in millimetres)

A : 99.04 mm C : 96.84 mm
B : 931.60 mm D : 820.53 mm

Roof bars and roof boxes

The design of your vehicle, for your safety and to avoid damage to the roof and tailgate, requires the use of roof bars and roof boxes that are tested and approved by AUTOMOBILES CITROËN.

Recommendations

- Distribute your load evenly, avoiding overloading on one side.
- Arrange the heaviest part of the load as close as possible to the roof.
- Anchor the load securely and signal if any part of it is overhanging.
- Drive gently, as the vehicle will be more liable to the effects of side winds (vehicle stability may be altered).
- Remove the roof bars as soon as they are no longer needed.

Bicycle carrier

Do not attach a bicycle carrier with straps to the following vehicle versions:

- C4 Picasso 5-seater (all versions) ;
- C4 Picasso 7-seater version with opening rear screen.

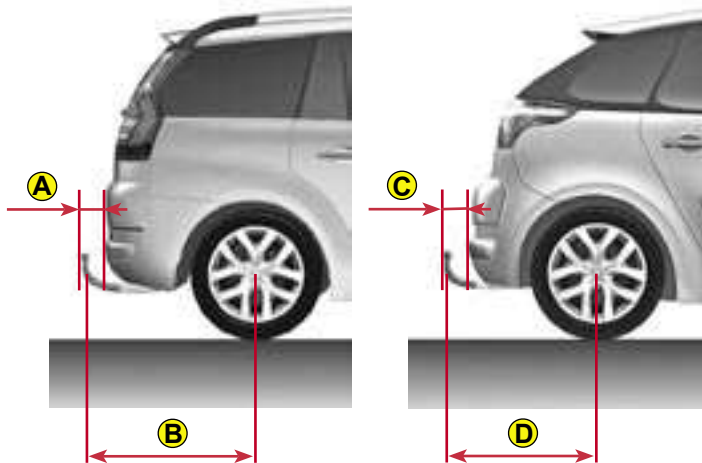

**Respect the authorised load capacities.
For maximum loads that can be distributed
on the roof bars:
See Chapter: "General information".**

CHANGING A WHEEL

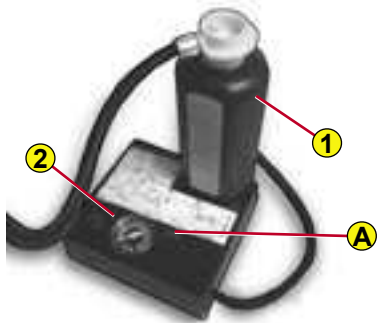

PUNCTURE REPAIR KIT

The puncture repair kit is to be found either in the compartment under the second-row passenger footwells or in the boot well (according to equipment).

The puncture repair kit is a complete system including a compressor and a setting product.

Using the puncture repair kit

1. Affix a speed limit sticker on the affected wheel, and one on the steering wheel, to remind you that you are driving with a wheel that is only fit for temporary use.
2. Clip the flask **1** on the compressor **2**.
3. Couple the flask **1** to the valve of the tyre to be repaired.
4. Couple the compressor pipe to the flask.
5. Connect the electric cable to one of the vehicle's 12V sockets.
6. Operate the compressor by pressing the button **A** until the pressure in the tyre reaches 2.0 bars. If you cannot make the pressure attain this level, then the tyre is not repairable.
7. Remove and stow the compressor.
8. Drive immediately for a few miles at reduced speed, in order for the repair to set.
9. Adjust the tyre pressure to the normal level for the vehicle, checking that there is no air escaping (no loss of pressure).
10. Drive at reduced speed (80 km/h / 50 mph). The tyre should be examined and repaired as soon as possible by a professional.

Note : After use, the flask should be stored in a plastic container (provided in the kit), so as not to soil your vehicle with residues of the fluid.

VI



Warning, the flask of puncture repair gel contains ethylene-glycol, a product that is toxic if ingested and irritating for the eyes.

Keep out of reach of children.

After use, do not dispose of the flask in the environment, but return it to a CITROËN dealer or alternatively to a recognised recovery facility.

This repair kit is available from a CITROËN dealer.

CHANGING A WHEEL

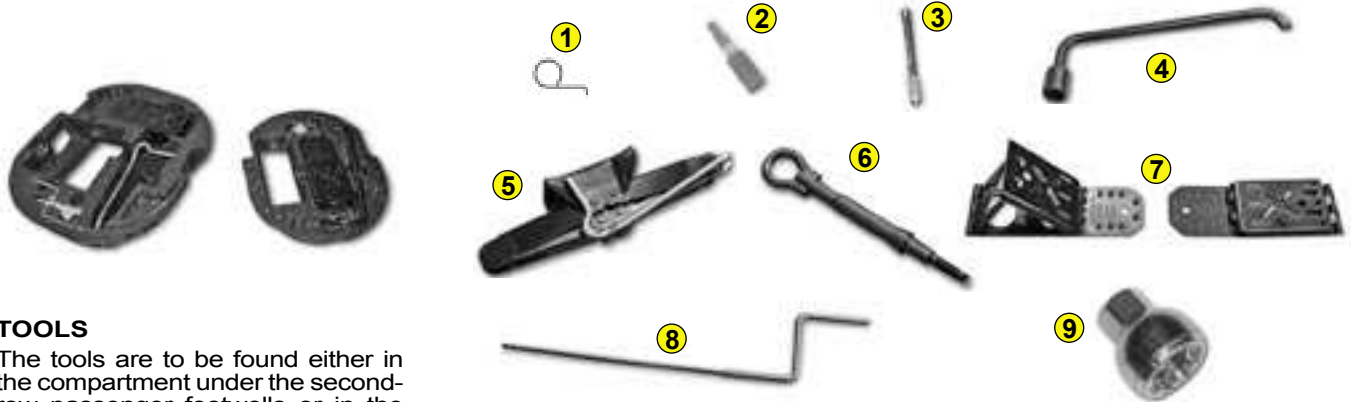

VI

TOOLS

The tools are to be found either in the compartment under the second-row passenger footwells or in the well under the third-row seats (according to equipment).

- 1 - Tool for removing the central trim on alloy wheels
- 2 - Tool for removing the chrome covers on the wheel bolts on alloy wheels
- 3 - Centring guide
- 4 - Tool for removing the wheel bolts

- 5 - Vehicle jack with handle
- 6 - Removable towing eye
- 7 - Two chocks, provided for changing a wheel or for other uses on the vehicle (such as unlocking the electric parking brake)

- 8 - Electric parking brake unlocking device
- 9 - Anti-theft socket.



**Never get underneath the vehicle if it is supported only by the jack.
The jack and all the tools are designed specifically for use on your particular vehicle.
Do not use them for any other applications.**

**Have the original wheel repaired and refitted as soon as possible.
It is essential not to exceed a speed of 80 km/h (50 mph) on your spare wheel.**

CHANGING A WHEEL



Grand C4 Picasso



C4 Picasso



ACCESSING THE SPARE WHEEL

1. Move the third-row seat, right-hand side (7 seater model).
2. Retrieve the extension that is attached to the rear of the seat well.
3. Engage the extension on the pinion located under the carpet in the seat well.
4. Using the wheel brace on the extension to turn the **pinion clockwise**, release the cable to lower the spare wheel to the ground.
5. Remove the wheel from under the vehicle, disengaging the linking plate in the centre of the wheel.

Note : The pinion to release the spare wheel is located under the boot carpet, on the right hand side in the wheel well for the Grand C4 Picasso and on the left hand side for the C4 Picasso.

STOWING THE AFFECTED WHEEL

1. It is essential to orient the valve upwards.
2. Pass the linking plate through the centre of the wheel (first removing the central trim on certain alloy wheels).
3. Turn the pinion **anti-clockwise** to draw in the cable. First the pinion will turn idly, then the cable will tighten to raise the wheel. Check that the wheel is tight against the vehicle floor and not interfering with other nearby components (e.g. the exhaust).
4. Stow the tools and chocks.

With the affected road wheel now under the vehicle floor, the vehicle has reduced ground clearance, so take extra care when reversing or driving on uneven surfaces, including kerbs.

Retrieval of the spare wheel and stowage of the affected road wheel are operations that should be done with the vehicle supported on its wheels, not by the jack.

CHANGING A WHEEL

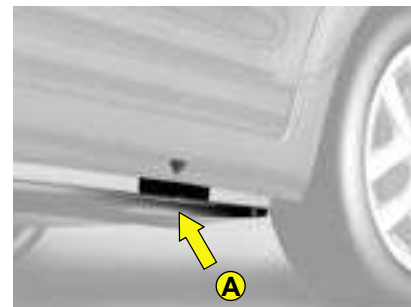
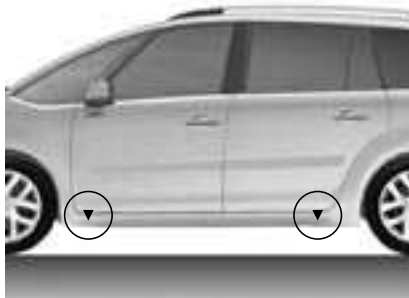

VI

REMOVING A WHEEL

1. Park the vehicle on level, stable and non-slippery ground. Apply the parking brake.
Switch off the ignition, check that the parking brake is applied (message and warning lamp in the instrument panel) and engage first gear or reverse gear depending on the slope (**P** if an automatic gearbox, **D** or **R** if a 6-speed electronic gearbox).
2. Use a chock to secure the vehicle more safely. Place the chock in front of the wheel that is opposite the wheel affected.

3. Detach the trim using the removing tool 4, pulling in the area of the valve.
For vehicles with alloy wheels, insert the trim removing tool 1 into the recess in the central trim and lever it off.
For vehicles with alloy wheels that have visible bolts, remove the chromes covers using the tool 2.

4. Slacken the wheel bolts. For vehicles with alloy wheels, undo the anti-theft bolts using tool 9.
5. Position the jack under the vehicle (see diagrams), at the jacking point **A** closest to the wheel to be changed.
6. Unwind the jack 5 until its bracket is in contact with the ground. Make sure that the jack is vertical under the jacking point used.
7. Continue to extend the jack so as to raise the vehicle.
8. Undo the wheel bolts and remove the wheel.

Before any operation of this sort, it is advisable to deactivate your pneumatic suspension (see « Pneumatic suspension »). When changing a wheel, it is essential to immobilise the vehicle on ground that is level, stable and non-slippery.

CHANGING A WHEEL



WHEEL FOR TEMPORARY USE

If your vehicle is equipped with a spare wheel for temporary use only, when fitting this it is normal to observe that the wheel bolts do not come to bear directly on the wheel rim.

The spare wheel is secured by the conical tapering of the wheel bolt's shaft (see illustration).

When refitting the original wheel, ensure that the wheel bolt contact surfaces are clean and in good condition.

REFITTING A WHEEL

1. Position the wheel with the aid of the centring guide **3**.
2. Do up the 3 bolts by hand, then remove the centring guide **3**. Position the 4th bolt.
3. Pre-tighten the wheel bolts, using the wheelbrace **4**.
4. Retract the jack **5** and disengage it.
5. Tighten the wheel bolts, using the wheelbrace **4**.
6. Ensure that the tyre pressure is correct (see "Vehicle identification").

WHEEL EQUIPPED WITH DEFLATION DETECTION SYSTEM

Such wheels have tyre pressure sensors. It is essential to have repairs carried out by a CITROËN dealer.

ANTI-THEFT BOLTS (alloy wheels)

Each wheel may be equipped with one anti-theft bolt.

To remove it :

1. Remove the protector that is covering it by means of the tool **2** (for removing the chrome covers on alloy wheels).
2. Use the anti-theft socket **9** with the handle.

DIMENSION OF THE SPARE WHEEL

If your spare wheel has dimensions different from those of the normal vehicle wheels (identified by a label), it is imperative to use the spare wheel only temporarily, to drive with caution, not to exceed 80 km/h (50 mph) and to have the tyre repaired and the normal wheel refitted as soon as possible.

Tyre pressures

These are indicated on the label on the front door pillar. See "Vehicle identification" and "User Precautions".



The wheel bolts are specific to each type of wheel.

If new wheels are fitted, check with your CITROËN dealer that the wheel bolts are compatible with the new wheels.

Note : take care to note down the code number on the head of the anti-theft bolt socket. This will enable you to obtain a replacement anti-theft socket from a CITROËN dealership.

TYRE DEFLATION DETECTION

This function alerts you in the event of a tyre being deflated or punctured. For this purpose, sensors continuously monitor the condition of the vehicle's wheels.

This system does not absolve the driver of the need to check the tyre pressures regularly.

Deflation warning



The **SERVICE** warning lamp comes on and a vehicle outline is displayed, accompanied by a message and a sound signal.

The wheel(s) concerned will be shown flashing on the vehicle outline. Check the tyre pressures as soon as possible.

Puncture



The **STOP** warning lamp comes on and a vehicle outline is displayed, accompanied by a message and a sound signal.

The wheel(s) concerned will be shown flashing on the vehicle outline. Stop the vehicle immediately, avoiding any violent actions on the steering wheel or brakes.

Change the damaged wheel (whether punctured or substantially deflated), have the tyre repaired as soon as possible, then check the tyre pressures as soon as you can after that.

The wheel affected will no longer be detectable by the alert system if it is in the boot or undergoing repair. The spare wheel is not monitored by the alert system.

Wheel not monitored

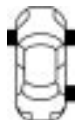

The **SERVICE** warning lamp comes on and a vehicle outline is displayed, accompanied by a message and a sound signal.

The wheel(s) concerned will be shown as absent on the vehicle outline. If you have not changed a wheel, this information indicates a malfunctioning of the system.

Consult the CITROËN network to have the defective sensor(s) replaced.

The deflation detection system is a driving assistance function which does not relieve the driver from the responsibility to be vigilant.

This system does not absolve the driver of the need to check the tyre pressures on a regular basis (see « Vehicle identification»), to ensure that the vehicle behaves as it should and to avoid premature wear on the tyres, especially when the vehicle is being subjected to heavy loads or driven at high speeds.

Do not forget to check the tyre pressure on the spare wheel.



Any repair or any change of tyre, on a wheel fitted with a sensor, should be carried out by a CITROËN dealer.

The system may be affected from time to time by interference from radio transmissions on similar frequencies.

TOWING - LIFTING

Removable towing ring

The towing ring is detachable and can be fitted either at the front or at the rear of the vehicle. It is stowed with the tools either in the storage flap under the second-row footwell or (according to equipment) in the boot well.



Advice

In exceptional circumstances, it is permitted to tow the vehicle at **low speed over a short distance** (depending on local legislation in force).

In all other cases, the vehicle must be transported by a transporter.

CAUTION - TOWING A VEHICLE WITH AUTOMATIC TRANSMISSION

Put the selector lever in position N (neutral).



Towing with all wheels on the ground

Towing ring fixings are placed at the front and at the rear of the vehicle.

To access them:

- at the front : push at top left, then pull on right.
- at the rear : push at bottom, then pull on top.

The cover remains attached to the bumper by means of a tab, so that it cannot become lost.

The ignition key should be in position "M" so as to retain steering.

Use a bar with hooks to attach on the towing rings.



**If the engine is not running, the steering and braking systems will not be power-assisted.
If towing another vehicle, the latter should be free-wheeling
(that is, gearbox in neutral).**

COLD WEATHER SCREEN

INSTRUCTIONS FOR FITTING THE SCREEN

Clip the component on the ribs of the front bumper.



Before fitting



After fitting

VI

The screen supplied with the vehicle (depending on destination) should be fitted during the winter period only and removed when ambient temperatures are above 10 degrees Celsius.

FUEL CONSUMPTION - IN LITRES/100 KM (MILES PER GALLON)

Engine type	1.8i 16v	2.0i 16V 143hp		HDi 110		HDi 138	
	BVM	BMP	BVA	BVM	BMP	BMP	BVA
Urban CO₂ emissions (g/km)	11.3 (25.0)	11.1 (25.4)	12.9 (21.9)	7.3 (38.7)	6.8 (41.5)	7.9 (35.8)	9.9 (28.5)
	269	263	306	190	176	206	262
Extra urban CO₂ emissions (g/km)	6.1 (46.3)	6.2 (45.6)	6.6 (42.8)	5.1 (55.4)	5.1 (55.4)	5.1 (55.4)	5.9 (47.9)
	145	148	157	135	135	132	156
Combined CO₂ emissions (g/km)	8.0 (35.3)	8.0 (35.3)	8.9 (31.7)	5.9 (47.9)	5.7 (49.6)	6.1 (46.3)	7.4 (38.2)
	190	190	211	155	150	159	195

These consumption values are established in compliance with European directive 80/1268/CEE. They can vary depending on how the vehicle is driven, on the prevailing traffic conditions, on weather conditions, on vehicle load, on how the vehicle has been maintained and also on how many accessories are in use

BVM : Manual gearbox.

BVA : Automatic gearbox.

BMP : Electronic Gearbox System.

These values apply to both Grand C4 Picasso and C4 Picasso.

The fuel consumption figures quoted are correct at time of going to press.

GENERAL INFORMATION

Engine type	1.8 16V	2.0 16V 143hp		HDi 110		HDi 138	
	BVM	BMP	BVA	BVM	BMP	BMP	BVA
Fuel tank capacity	Approximately 60 litres						
Fuels to be used	Unleaded petrol RON 95 – RON 98			Diesel fuel			
Turning circle between walls (in metres)	11.85						
French fiscal rating	8	9	9	6	6	8	9
Maximum power (kW)	92	103	103	80	80	100	100
Calculated maximum speed in km/h (mph) (in top gear)	185 (115)	195 (121)	190 (118)	180 (112)	180 (112)	195 (121)	190 (118)

VII

BVM : Manual gearbox.

BVA : Automatic gearbox.

BMP : Electronic Gearbox System.

These values apply to both Grand C4 Picasso and C4 Picasso.

GENERAL INFORMATION

Weights (kg) : Grand C4 Picasso	1.8 16V BVM	2.0 16V 143hp BVA	2.0 16V 143hp BMP	HDi 110 BVM	HDi 110 BMP	HDi 138 BMP	HDi 138 BVA	
Unladen weight	1510	1600	1560	1530	1539	1620	1650	
Gross vehicle weight	2200	2260	2240	2250	2250	2320	2350	
Maximum weight on rear axle	1210							
Gross train weight	3400	3660	3440	3130	3130	3620	3550	
Gross trailer weight	8 % < Incline ≤ 12 %	1200	1400	1200	880	880	1300	1200
	Incline ≤ 8 %	1700	1400	1700	1050	1050	1700	1440
With weight transfer (within gross train weight)	Incline ≤ 12%	1500	1500	1500	1180	1180	1500	1500
Trailer weight without brakes	750							
Trailer nose weight	60	60	60	50	50	70	70	
Maximum weight on roof bars	80							

GENERAL INFORMATION

VII

Weights (kg) : C4 Picasso		1.8 16V BVM	2.0 16V 143hp BVA	2.0 16V 143hp BMP	HDi 110 BVM	HDi 110 BMP	HDi 138 BMP	HDi 138 BVA	
5 seater version	Unladen weight	1470	1552	1511	1489	1499	1581	1640	
	Gross vehicle weight	2000	2090	2040	2050	2060	2140	2150	
	Maximum weight on rear axle	1000							
	Gross train weight	3400	3590	3440	3130	3130	3540	3550	
	Gross trailer weight	8 % < Incline ≤ 12 %	1400	1500	1400	1080	1070	1400	1400
		Incline ≤ 8 %	1700	1500	1700	1200	1200	1700	1600
	With weight transfer (within gross train weight)	Incline ≤ 12%	1500	1500	1500	1300	1300	1500	1500
	Trailer weight without brakes	750							
	Trailer nose weight	60							
	Maximum weight on roof bars	80							
4 seater Lounge version	Unladen weight	-	1600	1579	-	-	1615	1655	
	Gross vehicle weight	-	2070	2040	-	-	2090	2130	
	Maximum weight on rear axle	1000							
	Gross train weight	-	3570	3440	-	-	3490	3530	
	Gross trailer weight	8 % < Incline ≤ 12 %	-	1500	1400	-	-	1400	1400
		Incline ≤ 8 %	-	1500	1700	-	-	1700	1600
	With weight transfer (within gross train weight)	Incline ≤ 12%	-	1500	1500	-	-	1500	1500
	Trailer weight without brakes	750							
	Trailer nose weight	60							
	Maximum weight on roof bars	80							

GENERAL INFORMATION

Weights : refer to the manufacturer's identification plate.

Weight transfer : it is possible, when the towing vehicle is within the gross vehicle weight, to transfer weight allowance from the trailer, provided you do not exceed the gross train weight.

In all cases, do not exceed the gross train weight indicated.

The maximum speed of a towing vehicle is limited to 100 km/h (approx. 60 mph).

Observe your vehicle's towing limits. It is essential to comply with the max.

Gross Trailer Weights and speed limits as specified by legislation in each country.

For Belgium and Switzerland : see homologation documents.

Chainable tyres : consult a CITROËN dealer to know which tyres can be fitted with chains.

DIMENSIONS - GRAND C4 PICASSO AND C4 PICASSO (IN METRES)

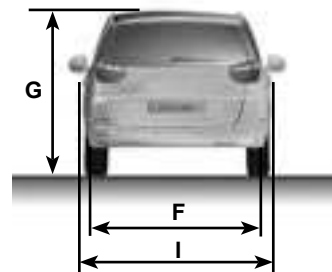
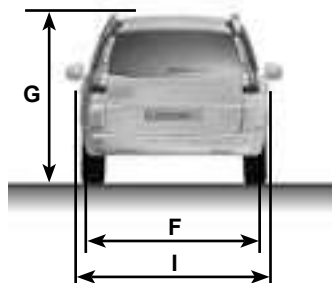
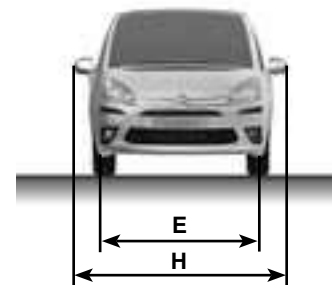
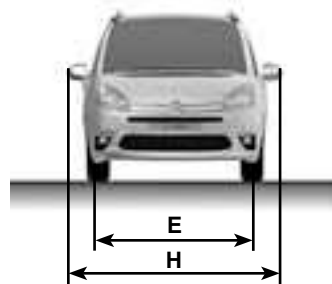
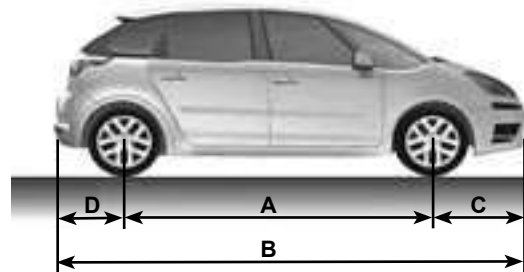
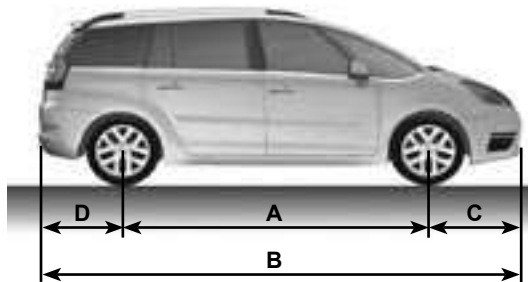

	Grand C4 Picasso	C4 Picasso
A	2.730	2.730
B	4.590	4.470
C	0.990	0.990
D	0.870	0.750
E	1.510	1.510
F	1.540	1.540
G*	1.660 to 1.710	1.660 to 1.680
H	2.100	2.100
I	1.830	1.830

* Depending on suspensions and roof bars.

DIMENSIONS - C4 PICASSO (IN METRES)

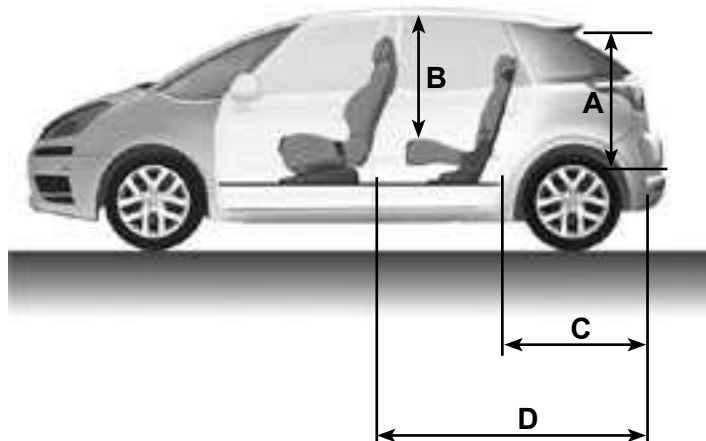

A	0.930
B	0.960/0.980
C	0.880/1.000
D	1.610/1.870

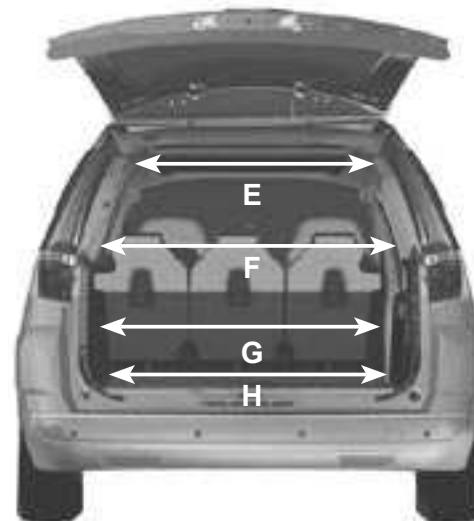

E	0.930
F	1.140
G	1.120
H	1.170

VII

DIMENSIONS - GRAND C4 PICASSO (IN METRES)

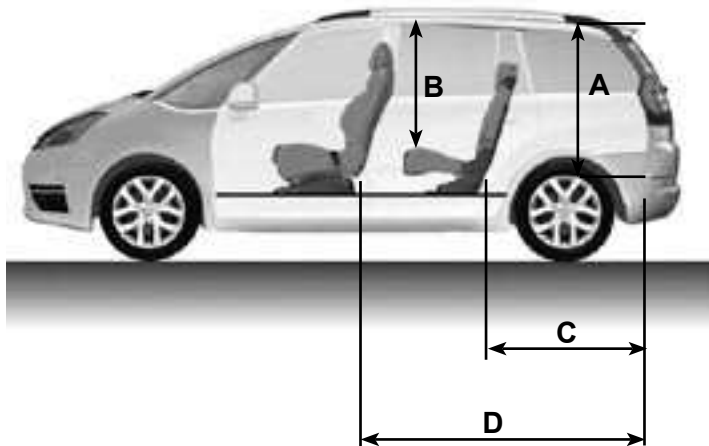

VII

A	0.920
B	0.990/1.000
C	1.030/1.160
D	1.800/2.060

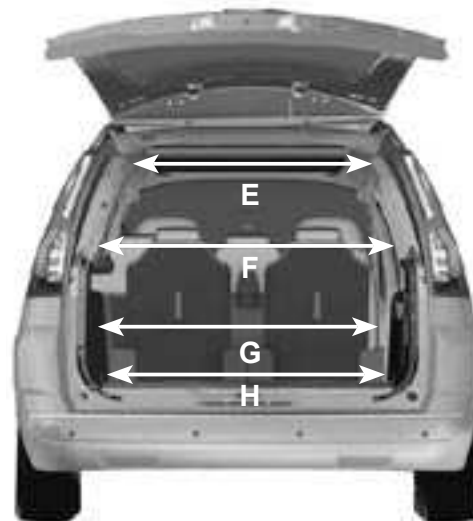

E	0.880
F	1.070
G	1.160
H	1.170

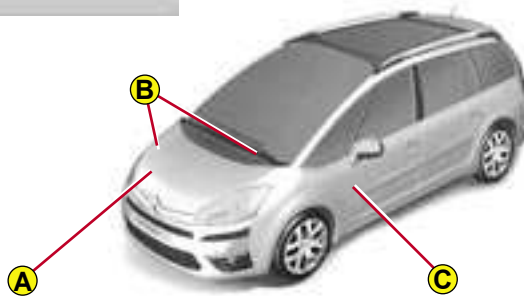
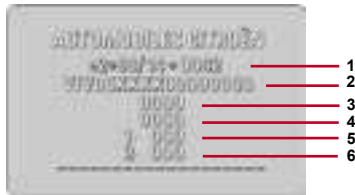

A Manufacturer's plate

In the engine compartment.

1. EU type approval number.
2. Vehicle identification No. (VIN).
3. Gross vehicle weight.
4. Gross train weight.
5. Maximum weight on front axle.
6. Maximum weight on rear axle.

B Vehicle identification No. (VIN)

On bodywork and behind wind-screen

C Paint colour code. Tyre reference. Tyre pressures.

The vehicle type and the identification number are also indicated on the registration document.

All CITROËN original replacement parts are available exclusively within the dealer network.

For your safety and in order to remain within the terms of the guarantee, you are advised to use only CITROËN replacement parts

CONTENTS

What is NaviDrive ?	1
Description of the controls	2
Voice commands.....	6
Main Menu.....	8
Navigation - Guidance	9
Map	18
Traffic information	22
Audio system (Radio, CD player, CD changer, MP3)	25
Telephone.....	42
Telematic services	48
Configuration.....	50
Vehicle diagnosis	52
Video	53
Frequently-asked questions.....	54
Index NaviDrive.....	56



NAVIDRIVE IS A SYSTEM WHICH ENABLES YOU:

- To navigate to the destination of your choice (European map on hard disc) including journeys to your Centres of interest (cinema, hotel, restaurant..) and taking account of traffic conditions.
- To listen to the radio.
- To listen to CDs / MP3 CDs.
- To copy CDs into your Jukebox source (10 Go's available on the hard disc).
- To telephone hands-free.
- To enjoy access to **CITROËN** services according to the country you are in (Citroën Emergency, Citroën Assistance, Citroën On line and NaviDrive services).
- To access a vehicle diagnosis menu.
- To connect a nomad audio/video device.

Your NaviDrive is coded so as to function only on your particular vehicle.

It cannot be used on any other vehicle.

The anti-theft system is automatic and requires no action on your part.

Your NaviDrive can operate without the ignition on for a maximum of 30 minutes depending on the level of charge of the vehicle battery.

DESCRIPTION OF THE CONTROLS

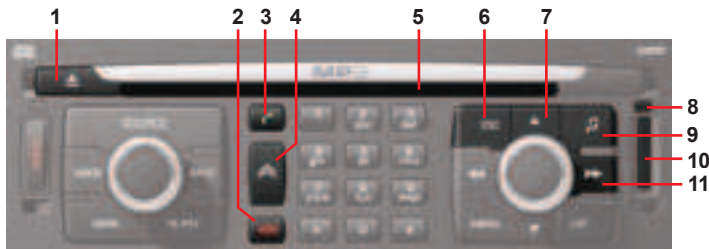

1	CD eject.
2	Call in progress: Short press: End a call.
3	Short press: Answer call. Display of telephone menu.
4	Short press: Access to the CITROËN services menu. Long press: Direct call to the CITROËN assistance service.
5	CD aperture.
6	Short press: <ul style="list-style-type: none"> • Cancellation of the current operation. • Deletion of a superimposed display. Long press: <ul style="list-style-type: none"> • Close main menu and return to the welcome screen.
7	Short press: Manual search of higher frequencies. Jukebox/CD/CD changer source MP3: Selection of the previous CD/previous directory. Other sources: Moving in the menus. In " Select - Move on map " mode, move upwards.

8	SIM card eject button.
9	Audio adjustments: Sound ambiances, bass, treble, loudness, fade, balance, speed-sensitive volume.
10	SIM card slot.
11	Radio sources: <ul style="list-style-type: none"> • Short press: Automatic search of higher frequencies. CD or CD changer source: <ul style="list-style-type: none"> • Short press: Search of the next track. • Long press: Fast forward with accelerated sound. Jukebox/MP3 CD source: <ul style="list-style-type: none"> • Short press: Search of the next track. Exploration: Movement in the menus and movement of the cursor in an entry zone. In " Select - Move on Map ": move to the right.



It is recommended that you do not use the NaviDrive controls while your vehicle is moving. In some countries, certain commands may be deactivated to comply with national regulations.

DESCRIPTION OF THE CONTROLS



12	<p>Rotate:</p> <ul style="list-style-type: none"> • Movement in the screen for choosing a function, a parameter or a value. • Decrease or increase of data in the case of an adjustment. • Scrolling of the elements to select from a list. • Modification of the scale of the map on the screen.
13	<p>Short press:</p> <ul style="list-style-type: none"> • Access to the contextual menu (shortcuts). • Validation of the function chosen or of the value modified. • Selection of an “adjustment” or “list” type parameter for modification. • Activation/Deactivation of a function. <p>Long press: Update of the list of radio stations available.</p>

14	<p>Radio source: Manual search of lower frequencies.</p> <p>Jukebox/CD/CD changer source MP3: Selection of the next CD/next directory.</p> <p>Other sources: Moving in the menus. In “Selection - Move on map” mode: move downwards.</p>
15	<p>Short press: Access to the Main Menu.</p> <p>Long press: Access to the Voice Commands menu, to the description of your equipment, to the démonstration of Navigation, to the status of services and to the level of charge of the reserve battery. In certain countries, this control is deactivated while the vehicle is moving.</p>
16	<p>Radio source:</p> <ul style="list-style-type: none"> • Short press: Automatic search of lower frequencies. <p>CD or CD changer source:</p> <ul style="list-style-type: none"> • Short press: Search of previous track. • Long press: Rapid reverse with accelerated sound. <p>Jukebox/MP3 CD source:</p> <ul style="list-style-type: none"> • Short press: Search of previous track. <p>Exploration: Movement in the menus and movement of the cursor in an entry zone.</p> <ul style="list-style-type: none"> • In “Select - Move on Map” : move to the left.

DESCRIPTION OF THE CONTROLS



17	<p>Other functions of the alphanumeric keypad:</p> <ul style="list-style-type: none"> • Radio source: <ul style="list-style-type: none"> - Short press: Recall of pre-set stations. - Long press: Pre-setting of stations. • CD changer source: Selecting a CD.
18	<p>Short press: Selection of frequency bands and memory banks. Long press: Automatic memorisation of FM stations available (Autostore).</p>

19	<p>Short press: On/Off for TA traffic information (Traffic Announcements). Long press: On/Off for PTY programme type (Program Type).</p>
20	<p>Press: On / Off. Rotate: Volume adjust.</p>
21	<p>Short successive presses:</p> <ul style="list-style-type: none"> • One press: Only the top part of the display remains lit. • Two presses: Display off (blank display). • Three presses: Return to the standard display. <p>Long press (more than 10 seconds): Re-initialisation of the system.</p>
22	<p>Short successive presses will display all the information relating to the following sources:</p> <ul style="list-style-type: none"> • Audio. • Telephone. • Trip computer. • Navigator.
23	<p>Long press (between 2 and 8 seconds): Emergency call.</p>
24	<p>Short press: Selection of the audio source (Radio, CD, CD changer, Jukebox). Long press: Copy of a CD on Jukebox source.</p>

DESCRIPTION OF THE CONTROLS ON THE STEERING WHEEL

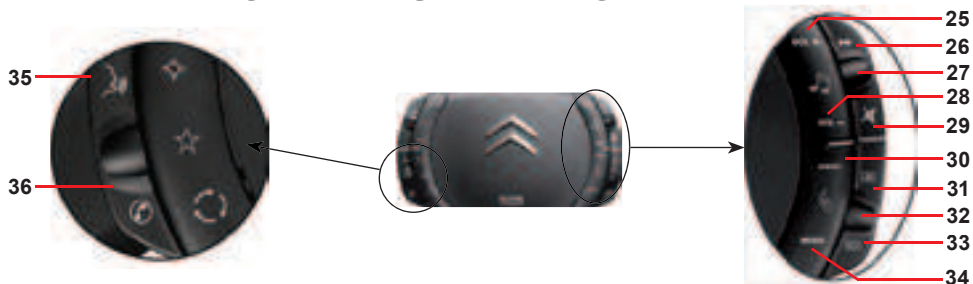

25	Volume increase.	28	Volume decrease.
26	<p>Radio source: Short press: Automatic search of higher frequencies.</p> <p>CD or CD changer source:</p> <ul style="list-style-type: none"> • Short press: Search of the next track. • Long press: Fast forward with accelerated sound. <p>Jukebox source:</p> <ul style="list-style-type: none"> • Short press: Search of the next track. 	29	Temporary sound pause / Restoration of sound: Mute.
27	<p>Radio source:</p> <ul style="list-style-type: none"> • Scrolling of pre-set stations. <p>CD source: Search of the track.</p> <p>CD changer source:</p> <ul style="list-style-type: none"> • Selection of next or previous CD. <p>MP3 CD / Jukebox source:</p> <ul style="list-style-type: none"> • Selection of the next or previous album. <p>Other sources:</p> <ul style="list-style-type: none"> • Selection of the next or previous elements of a menu in a screen, a list, an alphabet. 	30	<p>Main menu access button: To comply with legislation in certain countries, the “Menu” button is deactivated while the vehicle is moving.</p>
27		31	<p>Validation button: Validation of the function chosen or of the value modified.</p>
		32	Scrolling of the elements to select from a list.
		33	<p>Cancel or delete button:</p> <ul style="list-style-type: none"> • Short press: Cancellation of the current operation. • Long press: Deletion of a superimposed display.
		34	Selection of the type of information displayed on the right of the screen.
		35	Activation/Deactivation of the voice recognition control.
		36	<p>Not in communication</p> <ul style="list-style-type: none"> • Press: Access to the telephone contextual menu. <p>If there is an incoming call</p> <ul style="list-style-type: none"> • Short press: Answer call. • Long press: Refuse the call. <p>During a call</p> <ul style="list-style-type: none"> • Short press: End a call. • Long press: Access to the telephone contextual menu.

DESCRIPTION OF THE CONTROLS

VOICE

WHAT IS A VOICE COMMAND ?



You can operate Navidrive using your voice.

NaviDrive lets you access certain functions by pronouncing the corresponding voice label:

- Using pre-recorded words and expressions, for example: **“Radio”**, **“Help”**.
- Using a label recorded by the user.

To associate a voice label to a directory file, select this file.

Record a voice label for this file (e.g. **“Office”** or **“Home”**).



To enhance the efficiency of recognition of the labels in your directory files, it is recommended to record them with different intonations.

The voice commands function in a logical sequence. A word voiced at one level must be recognised before another word at the next level can be recognised.

HOW TO ACTIVATE VOICE RECOGNITION ?



press on the voice recognition button.

Activation of the function is confirmed by a beep and by the opening of a window on the display.

The system is then listening:

- If the word pronounced is understood by the system, it is displayed in the window and you hear a beep.
- If the word pronounced has not been understood, the system displays and announces **“Sorry”**.

You must then repeat the words.

Example

To call a number in your telephone directory:

- press on the voice recognition button.
- Pronounce the word **“Telephone”**.
- Wait for the system to answer with a beep.
- Pronounce the word **“Directory”**.
- Wait for the system to answer with a beep.
- Finally pronounce for example the label **“Home”**.

After the double beep, the desired action is performed.

Say the key words that correspond to the action that you wish carried out.

HOW TO DEACTIVATE VOICE RECOGNITION ?

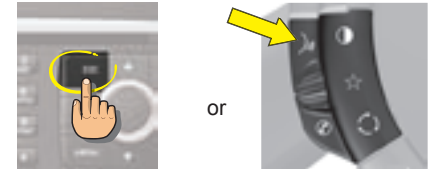

- Press on the control ESC or on the voice recognition button to deactivate voice recognition.

Note: Voice recognition deactivates automatically:

- following an action using voice commands (emission of a double beep),
- after a few seconds with no voice commands (the system says **“End of recognition”**).



If you say the word **“Help”** and **“What can I say”**, you will see displayed all the commands that are available at the moment of this request.

If you should lose your way in the different levels of the voice command structure, say the word **“Cancel”** to bring you back to the voice commands at the previous level of the structure.

However careful the user may be, the pre-recorded words or expressions will always be more easily recognised than words recorded by the user.

LIST AND STRUCTURE OF VOICE COMMANDS

HOW TO ACCESS THE LIST OF PRE-RECORDED VOICE COMMANDS?



Press on the end of the lighting control stalk to start voice recognition and say “Help” or “What can I say” to display the list of voice commands that are available.

Display	Audio		Detail page 27	
	Navigator		Detail page 11	
	Trip computer			
Telephone	Telephone		Detail page 44	
	Voice mail		Detail page 44	
	Redial			
Call	Adress book	<i>“Pre-recorded label”</i>	Detail page 44	
	<i>“Pre-recorded label”</i>		Detail page 46	
Message	Display		Detail page 47	
	Read		Detail page 47	
Navigator	Stop		Detail page 11	
	Adress book	<i>“Pre-recorded label”</i>	Detail page 12	
	Restart		Detail page 11	
	Show	Destination		Detail page 24
		Vehicle		Detail page 24
	Zoom out		Detail page 18	
Zoom in		Detail page 18		
Guide to	<i>“Pre-recorded label”</i>			
Traffic Info	Display		Detail page 24	
	Read		Detail page 24	
Radio			Detail page 33	
Radio	Autostore		Detail page 31	
	List		Detail page 31	
	Memory	1-6	Detail page 30	
	Previous		Detail page 30	
	Next		Detail page 30	

CD player			Detail page 35	
CD player	Random		Detail page 28	
	List			
	Track number	1-20		
	Previous track			
	Next track			
	Scan		Detail page 28	
	Folder	Repeat		
		Next		
Previous				
Jukebox			Detail page 37	
Jukebox	Random		Detail page 28	
	List			
	Track number	1-20		
	Previous track			
	Next track			
	Scan		Detail page 28	
	Folder	Repeat		
		Next		
Previous				
CD changer			Detail page 41	
CD changer	Disc number	1-5	Detail page 41	
	Previous disc			
	Next disc			
	Random		Detail page 28	
	List			
	Track number	1-20	Detail page 41	
	Previous track		Detail page 41	
	Next track		Detail page 41	
	Repeat			
	Scan		Detail page 28	

MAIN MENU

HOW TO ACCESS THE MAIN MENU ?



Press on the MENU button.



To keep the display clean, it is recommended to wipe with a soft, non-abrasive cloth (e.g. for spectacles) without any cleaning product added.

NAVIGATION/GUIDANCE

GENERAL

WHAT IS THE NAVIGATION SYSTEM ?

The on-board navigation system uses audible and visual instructions to guide you towards the destination of your choice.

The system uses GPS and a mapping database stored on a hard disc.

The GPS system enables your position to be plotted via contact with a number of satellites.

The navigation system is composed of the following elements:

- A synthesised voice for enunciating the guidance instructions during navigation.
- A multifunction display.
- A GPS aerial.
- Controls on your NaviDrive as well as on the steering wheel.

WHAT YOU NEED TO DO IN ORDER TO USE THE NAVIGATION SYSTEM ?

You have to initialise the navigation system:

- when you first use the navigation
- following a battery disconnection.

Park the vehicle in the open air so that it can make contact with a satellite.

Place the ignition key in the "Ignition" position for 15 minutes.

If the navigation system has difficulty in receiving its GPS positioning from satellites, this may be caused by the presence of bridges, underground car parks, etc., which may temporarily interfere with vehicle location or guidance calculation.

HOW TO ACTIVATE A NAVIGATION SYSTEM DEMONSTRATION ?



The demonstration gives you a simulation of the Navigation function.

The demonstration only operates if the Navigation function is displaying (successive presses on button MODE).

- Keep the MENU button pressed.
- Enter a destination (see "How to enter an address?").
- Launch Navigation to start the demonstration.

The departure point will be either the current location of the vehicle or the last location known.



You can use the demonstration menu to enter a different point of departure to where you are now. This lets you plan a trip that you are wishing to make.



If your NaviDrive should malfunction, press for at least 10 seconds on the DARK button to re-initialise the system.

NAVIGATION/GUIDANCE

GENERAL

DESCRIPTION OF THE TYPES OF INFORMATION DISPLAYED DURING NAVIGATION

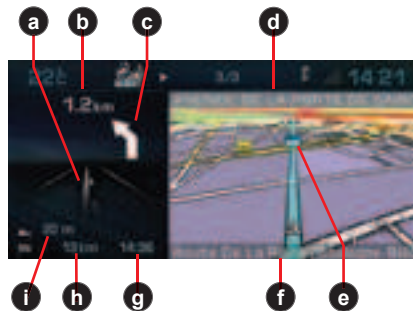

The Multifunction screen

During a guidance, you have access to the following types of information:

- a Manoeuvre to be made, or direction to be taken.
- b Distance to the next manoeuvre.
- c Next manoeuvre to be made.
- d Next road to be taken and name of town.
- e Symbol concerning Traffic information or the services that are in proximity.
- f Road you are currently on, name of the town.
- g Estimated time of arrival at destination (based on flowing traffic).
- h Distance to final destination.
- i Altitude.

THE VOICE SYNTHESIS



Apart from on the screen, the manoeuvres to be made are announced by a voice synthesiser.

Repeating the last piece of voice information

A few seconds after enunciation of a guidance voice instruction, you have the possibility of hearing it again.

Keep the end of the lighting control stalk pressed.

How to adjust the volume for the voice instructions ?



While a voice instruction is being spoken, press on the volume adjustment button controls either on the system or on the steering wheel.

Adjustment is also possible in the "Configuration" menu.

NAVIGATION/GUIDANCE

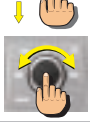

ACCESSING THE MENU

HOW TO ACCESS THE NAVIGATION/GUIDANCE MENU ?

	<ul style="list-style-type: none">• Press button MENU.	
	<ul style="list-style-type: none">• Rotate the control to select the Navigation/Guidance icon A.• Press on the control to validate.	

HOW TO ACCESS THE NAVIGATION MENU SHORTCUTS ?

When the Navigation function is displayed (successive presses on the MODE button), the Navigation menu shortcuts give you access to the main Navigation functions.

	<ul style="list-style-type: none">• Press on the control. A window opens. <ul style="list-style-type: none">• Rotate the control to select the option of your choice.• Press on the control to validate.	
--	---	---

The shortcut options available allow you:

- **B** to resume or stop the guidance towards the last destination entered
- **C** to divert an itinerary according to the number of kilometres (or miles) that you will have indicated
- **D** to define or modify the calculation criteria for the itinerary (shortest way, quickest way. etc.),
- **E** to access the list of Traffic information messages,
- **F** to move the pointer on the Map.

NAVIGATION/GUIDANCE MENU STRUCTURE

WHAT ARE THE FUNCTIONS OF THE NAVIGATION/GUIDANCE MENU ?

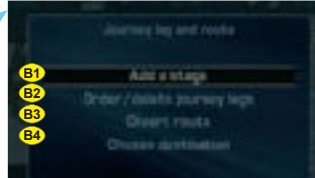
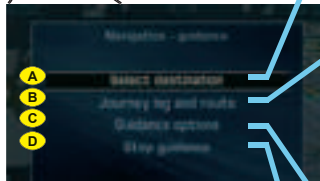

A CHOOSE A DESTINATION

- A1 Enter a city name, a street name, a street no. or intersection.
- A2 Enter the GPS coordinates for a location.
- A3 Select a location that is stored in the directory.
- A4 Select a location from among the last twenty destinations requested.

B ENTER STAGES AND ITINERARY

- B1 Add a stage to an itinerary after starting a guidance.
- B2 Order or delete stages when creating an itinerary.
- B3 Divert an itinerary according to the number of kilometres (or miles) you will have indicated (for example to avoid a traffic hold-up).
- B4 Alter the destination initially chosen.

C SET PARAMETERS FOR THE GUIDANCE OPTIONS







- C1 Defining the route calculation criteria.
- C2 Adjust the volume of the voice synthesis.
- C3 Activate/Deactivate the pronunciation of a street name in the voice instructions.
- C4 View the types of navigation information available on the hard disc.
- C5 Delete the last destinations automatically memorised.

D STOP/RESUME THE CURRENT GUIDANCE

NAVIGATION/GUIDANCE

ENTER AN ADDRESS (1/2)

HOW TO ENTER AN ADDRESS ?

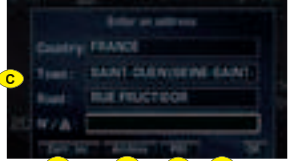
	<p>In the Navigation/Guidance menu:</p> <ul style="list-style-type: none">• Rotate the control to select the menu A.• Press on the control to validate.	
	<ul style="list-style-type: none">• Rotate the control to select the menu B.• Press on the control to validate. <p> The last guidance address is displayed.</p>	
	<ul style="list-style-type: none">• Rotate the control to select the field C.• Press on the control to validate.• Rotate the control or use the alphanumeric keypad to select the letters composing the name of the town.• Press on the control to validate each letter. <p>After the first letter has been validated, only those letters that can complete an existing name in the database will be displayed.</p> <p>At the time of the entry you can select the following functions:</p> <ul style="list-style-type: none">- D to see list of the towns commencing with or comprising the same letters (when the list contains only 6 names of towns, these display automatically),- E to display the address corresponding to the vehicle's current position,- F to select a Centre of interest (POI): the address displays automatically,- G to store the displayed address in a directory file. <ul style="list-style-type: none">• Rotate the control to select the option desired.• Press on the control to validate.	



To go faster, enter the postcode instead of the name of the town.

NAVIGATION/GUIDANCE

ENTER AN ADDRESS (2/2)

- In the same way enter the name of the road without indicating the type of road (street, avenue, etc.).

- Rotate the control to select the field H.
- Press on the control to validate.
- Rotate the control or use the alphanumeric keypad to select the figures that make up the street number.
- Press on the control to validate each figure.



The first is the last street no. figure displayed.



When the street nos. are not recorded in the database, your NaviDrive automatically offers you a list of the streets intersecting with that named.
You also have access to the list of intersections by selecting the field I

When the complete address has been entered:

- Rotate the control to select the field OK.
- Press on the control to validate.



- Rotate the control to define the calculation criterion you prefer:
 - Quickest route
 - shortest route
 - route offering the optimum distance/time relationship.

Note: If you modify one of the criteria during a guidance, the itinerary can be altered.

- You can also select routes favouring:
 - toll roads (motorways, bridges)
 - traffic information with the possibility of diverting the route according to the messages (See "Traffic information") (advised).
- Press on the control to validate.
- Start the guidance by selecting OK and press on the control to validate.

Note: After starting a guidance, a display informs you on the precautions in force concerning the use of navigation.

- If you accept its content, press on the control

Respect the road regulations that are in force.







If you only indicate a town name, you will be automatically guided towards the town centre.





NAVIGATION/GUIDANCE

ADDING A STAGE

HOW TO ADD A STAGE TO AN ITINERARY ?

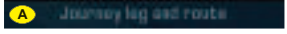
	<p>During guidance, in the menu Navigation/Guidance:</p> <ul style="list-style-type: none">• Rotate the control to select the menu A.• Press on the control to validate.	
	<ul style="list-style-type: none">• Rotate the control to select the menu B.• Press on the control to validate.	
	<ul style="list-style-type: none">• Enter the address of the additional stage. See "How to enter an address?".• Press on the control to validate.	
 The stage has to be either reached or deleted in order for you to be able to continue beyond this stage.		







HOW TO CHANGE THE SEQUENCE OF STAGES ?

	<p>During guidance, in the menu Navigation/Guidance:</p> <ul style="list-style-type: none">• Rotate the control to select the menu A.• Press on the control to validate.	
	<ul style="list-style-type: none">• Rotate the control to select the menu C.• Press on the control to validate.	
	<ul style="list-style-type: none">• Rotate the control to select the stage to be moved.• Press on the control to validate. <ul style="list-style-type: none">• Rotate the control to select:<ul style="list-style-type: none">- D to move the selected stage higher in the list.- E to move the selected stage lower in the list	
 The itinerary is recalculated automatically according to the sequence of stages.		

NAVIGATION/GUIDANCE

USING THE DIRECTORY

HOW TO START A GUIDANCE FROM AN ARCHIVED ADDRESS ?

	<p>In the Navigation/Guidance menu:</p> <ul style="list-style-type: none"> • Rotate the control to select the menu A. • Press on the control to validate. 	
	<ul style="list-style-type: none"> • Rotate the control to select the menu B. • Press on the control to validate. 	
	<p>When the address stored in the file is displayed:</p> <ul style="list-style-type: none"> • Rotate the control to select a file. • Press on the control to validate. 	
	<ul style="list-style-type: none"> • Rotate the control to select OK. • Press on the control to validate. <ul style="list-style-type: none"> • Rotate the control to define the calculation criterion you prefer: <ul style="list-style-type: none"> - Quickest route - shortest route - route offering the optimum distance/time relationship. <p>Note: If you modify one of the criteria during a guidance, the itinerery can be altered. You can also select routes favouring:</p> <ul style="list-style-type: none"> - toll roads (motorways, bridges) - traffic information so that you have the possibility to divert the route according to the messages (See "Traffic information") (advised). <ul style="list-style-type: none"> • Press on the control to validate. • Start the guidance by selecting OK and press on the control to validate. <p>Note: After starting a guidance, a display informs you on the precautions in force concerning the use of navigation.</p> <ul style="list-style-type: none"> • If you accept its content, press on the control. <p>Respect the road regulations that are in force.</p>	 











Remember to archive your address in a file.

NAVIGATION/GUIDANCE

START GUIDANCE TO A CENTRE OF INTEREST (POI)

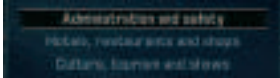
HOW TO START A GUIDANCE TO A CENTRE OF INTEREST ? (LIST PAGE 21)

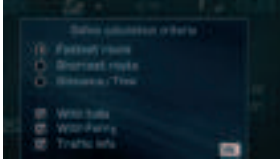
	<p>In the Navigation/Guidance menu:</p> <ul style="list-style-type: none"> • Rotate the control to select the menu A. • Press on the control to validate. 	
	<ul style="list-style-type: none"> • Rotate the control to select the menu B. • Press on the control to validate. <div style="border: 1px solid black; background-color: #ffffcc; padding: 5px; margin-top: 10px;">  The last guidance address is displayed. </div>	
	<ul style="list-style-type: none"> • Rotate the control to select C. • Press on the control to validate. 	
	<ul style="list-style-type: none"> • Rotate the control to select the location of the Centre of interest: <ul style="list-style-type: none"> - around the final destination of the itinerary, - anywhere on the route, - around the current location of the vehicle, - you can also do a name search. • Press on the control to validate. <ul style="list-style-type: none"> • Rotate the control to select the category of Centre of interest that you require. • Press on the control to validate. <div style="border: 1px solid black; background-color: #ffffcc; padding: 5px; margin-top: 10px;">  When you have finished defining the category of centre of interest required, a list of corresponding locations comes up. </div>	
	<ul style="list-style-type: none"> • Rotate the control to select the location of the Centre of interest. • Press on the control to validate. <p>The address of the Centre of interest displays automatically.</p>	
	<ul style="list-style-type: none"> • Rotate the control to define the calculation criterion you prefer (see “How to enter an address ?”). • Press on the control to validate. • Start the guidance by selecting OK <p>Note: After starting a guidance, a display informs you on the precautions in force concerning the use of navigation.</p> <ul style="list-style-type: none"> • If you accept its contents, press on the control. <p>Respect the road regulations that are in force.</p>	

MAP GENERAL

WHAT IS THE MAP MENU ?

The map menu lets you set parameters for the display and to access the information available on the map.

The mapping data is stored directly on the hard disc of your NaviDrive.

MODIFY THE ORIENTATION OF THE MAP

You can define 3 orientations for the map of your NaviDrive.



• Viewing in 3D

Your NaviDrive gives you a view of the map in 3D.

• Vehicle orientation

The time turns with the vehicle. The arrow showing the orientation of your vehicle remains fixed.

• North orientation

The map is fixed and oriented to North. The arrow showing the orientation of your vehicle moves on the map.

DISPLAY OF THE MAP

Your NaviDrive allows you to select 2 types of displays for the map.



• Full screen mode

The map appears full screen on the display.

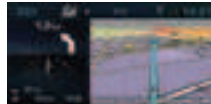

• Window mode

The map is shown on the right of the screen.

HOW TO MOVE THE POINTER ON THE MAP ?

You can move on a map in order to view the centres of interest, observe an area, etc



1. Move to the North.
2. Move to the West.
3. Move to the South.
4. Move to the East.

Note: Keep the button pressed to accelerate the movement on the map.



HOW TO MODIFY THE SCALE OF THE MAP ?

When the map is displayed, rotate the control to modify the scale.

The scale of the map can be varied between 50 m/cm and 200 km/cm.

When the scale is less than or equal to 10 km, the map goes automatically to North orientation.





Regular updates of the Map database are available. Contact a CITROËN dealer.

MAP

ACCESSING THE MENU - STRUCTURE

HOW TO ACCESS THE MAP MENU ?

	<ul style="list-style-type: none">• Press button MENU.	
	<ul style="list-style-type: none">• Rotate the control to select the Map icon A.• Press on the control to validate.	

WHAT ARE THE FUNCTIONS OF THE MAP MENU ?



A ORIENT THE MAP

- A1 Orient the map to the direction the vehicle is headed.
- A2 Orient the map to the North.
- A3 View the map in perspective.

B DISPLAY ON THE MAP THE DETAILS OF THE CENTRES OF INTEREST (POI) AVAILABLE (LIST PAGE 21)

C MODIFY THE DISPLAY OF THE MAP

- C1 Display the map full screen.
- C2 Display the map on the right of the screen.

D MOVE THE POINTER ON THE MAP

MAP

SELECTING A CENTRE OF INTEREST (POI)

HOW TO SELECT AND ADD A CENTRE OF INTEREST ON THE MAP?

II

In the Map menu:

- Rotate the control to select the menu **B**.
- Press on the control to validate.



A pointer appears on the map.

- Move it to a centre of interest symbol. See “How to move the pointer on the Map ?”
- Press on the control to access the contextual menu for the centre of interest.
- Rotate the control to select the function desired.
- Press on the control to validate.

You can select the following functions:



- **C: obtain information on the category of centre of interest.**
- **D: define the Centre of interest as a new destination of an itinerary.**
- **E: define the centre of interest as a stage of an itinerary.**
- **F: record the address of the centre of interest in a directory file.**
- **G: return to guidance mode.**

B

Move the map

C

Info on location

D

Select as destination

E

Select as stage

F

Save the place







G

Back map mode











MAP

LIST OF CENTRES OF INTEREST (POI)









PUBLIC AUTHORITIES AND SECURITY

-   City hall, City centre
-   School, university, college
-  Hospital
-  Police
-  Law Courts

HOTELS, RESTAURANTS, BUSINESS AND RETAIL PARKS

-   Selected hotels
-   Selected restaurants
-   Michelin guides
-  Vineyards
-   Supermakets, Shopping malls
-   Retail parks, trading estates

















CULTURE, TOURISM, ENTERTAINMENT

-  Culture, museums and theatres
-    Historic monuments, tourist attractions
-   Casinos and night life
-  Cinemas
-  Exhibitions

SPORTS AND OPEN AIR CENTRES

-   Sports centres and complexes
-  Golf courses
-   Skating, Bowling
-  Winter sports
-  Parks, gardens
-  Public attractions

TRANSPORT AND MOTORING

-  Activity centre
-  Customs
-   Airports, flying clubs
-   Rail stations, bus stations
-  Car hire
-     Car parks, rest areas
-   Ferry terminals, port areas
-   Service stations, garages
-  Radar zones/High-accident zones (depending on the country of marketing and availability of the service)
-  CITROËN Dealer or Repairer

TRAFFIC INFORMATION

GENERAL

WHAT IS THE “TMC” TRAFFIC INFORMATION FUNCTION ?

TMC traffic information consists of messages transmitted by FM radio stations.

As opposed to the road information flashes broadcast by radio (TA), TMC (Traffic Message Channel) messages are coded and silent. You can filter the types of information that interest you.

Your NaviDrive issues messages written in the selected language (including in a foreign country where your language is not that of the local radio stations).

The messages contain:

- The date and the time of the broadcast
- the nature of the incident
- the location
- the name
- the direction of traffic on the artery concerned.

A message is sent when an event occurs. You are again informed of the event when you are coming into proximity. The messages are classed according to the distance of the event from your vehicle.

The list of messages is updated every 15 minutes approximately.

LIST OF TMC SYMBOLS

Traffic information is shown on the map by means of the symbols opposite.

Note: These symbols may be accompanied by an arrow indicating in which traffic direction they are situated.





















Quality of the TMC information

Depending on the station selected, the traffic information may be more or less complete and precise, or cover a larger or smaller area. Each radio station is individually responsible for the quality of the information that it broadcasts.

AVAILABILITY OF THE TMC INFORMATION

When the FM station selected is able to broadcast TMC information, the multifunction screen displays the symbol “TMC”.

When the FM station selected is unable to broadcast TMC information, the “TMC” symbol appears shaded.

	Road conditions and dangers
	Accident
	Vehicle overturned
	Vehicle broken down
	Slippery road
	Road works
	Loose chippings on the road
	Temporary traffic lights
	Road closed
	Two-way traffic
	Exit closed
	Access closed
	Bottleneck
	Carriageway narrows
	Vehicle size restrictions
	Parking
	Information
	Weather
	Rainstorm
	Snowstorm
	Strong winds





The availability of traffic information depends on the country and on the region where you are driving.
The TMC traffic information can be read by the voice synthesiser.

TRAFFIC INFORMATION

ACCESSING THE MENU - STRUCTURE

HOW TO ACCESS THE TRAFFIC INFORMATION MENU ?

	<ul style="list-style-type: none">• Press button MENU.	
	<ul style="list-style-type: none">• Rotate the control to select the Traffic Information icon A.• Press on the control to validate.	

iii

WHAT ARE THE FUNCTIONS OF THE TRAFFIC INFORMATION MENU ?



A ACCESSING THE LIST OF MESSAGES

B FILTERING TMC INFORMATION

- B1** Select the information relating to a geographical area.
- B2** Select the information relating to traffic.
- B3** Select the information relating to built-up areas.

C SETTING PARAMETERS FOR MESSAGE ANNOUNCEMENTS

- C1** Activate or deactivate the reading of new messages by the NaviDrive voice.
- C2** Activate or deactivate the display of new TMC messages (do not select the tab for the regions with dense traffic).

D CHOOSING A TMC STATION

- D1** Access the list of TMC stations.
- D2** Select an automatic TMC search.
- D3** Select a manual TMC search.

TRAFFIC INFORMATION

FUNCTIONS IN DETAIL

CONSULTING OF MESSAGES

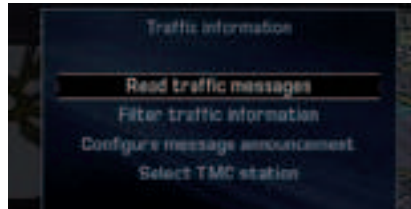

This menu gives you access to the **list of messages**:

- Certain of these messages may offer you a diversion from your route, depending on the TMC information received (it is necessary for you to have selected the “**traffic info**” guidance option). If you accept one of these messages, then the NaviDrive offers you a diversion and recalculates your itinerary. You can then choose whether or not to accept the offer.
- A message is sent to you when the decision is imminent. You are informed again as you approach the junction.

FILTERING TMC INFORMATION



The filters enable you to select the types of information which you wish to receive.

This menu gives you access:

- To the **geographical filter**: information concerning incidents situated around your vehicle, around a given location and/or on an itinerary (radius of 3 to 200 km),
- To **road information**: information concerning road incidents such as traffic, road closures, height/width limitations, state of the roadway or weather conditions (depending on the information available).
- To **urban traffic information**: information concerning the town where you are, such as parking, public transport and demonstrations (depending on the information available).

The filters can be cumulative.

If no filter is selected, all the TMC information will be displayed.

HOW TO DIVERT A ROUTE AS A RESULT OF TRAFFIC INFORMATION ?

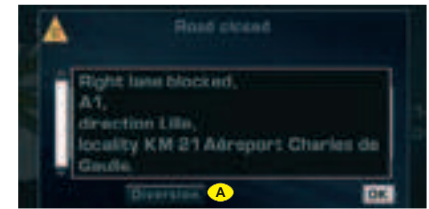

Depending on the filters that you choose for Traffic Information, your NaviDrive is able to allow you to divert your journey.

If a significant incident arises on your route, a window opens and informs you of the problem.

To account for this incident in your journey and to modify your itinerary:

- Rotate the control to select **A**.
- Press on the control to validate.

Your NaviDrive offers you a new itinerary.



You can consult a message by selecting on the map (see “Move the pointer on the map”).



To make the best use of the filters in your NaviDrive, we advise you to select a filter around your vehicle of:

- 5 km or 10 for a region with dense traffic,
- 20 km for a region with normal traffic,
- 100 km for long, motorway-type journeys.

AUDIO

GENERAL

WHAT DOES THE AUDIO SYSTEM COM- PRISE ?

Your audio system uses 5 sources:

- Radio source,
- CD source,
- Jukebox source,
- Audio/video auxiliary input,
- CD changer (according to equipment)

1- RADIO SOURCE

The radio of your NaviDrive system allows you:

- to listen to radio stations on waveband AM or FM,
- to search for the strongest reception possible thanks to the RDS system,
- to obtain traffic information (TA) over a current programme
- to select radio stations according to your choice of programme type (PTY).

2- THE CD/CD MP3 SOURCE

The CD player of your NaviDrive allows you:

- to playback CDs/CD MP3,
- to play back the start of each album, thanks to Introscaan,
- to display information about the CD (artist, name of the album, etc.) provided the CD is compatible with CD Textformat.

3- JUKEBOX SOURCE

Jukebox source lets you copy and store around 140 CDs or 14 CD MP3 (depending on the compression rate).

10 Goes on the hard disc of your NaviDrive are reserved for Jukebox source.

When you copy a CD MP3, Jukebox source deletes all the levels of covers, retaining only the 2 latest.

Copying from Jukebox source to a CD is not possible.

• Playlist

Playlist is a function available in Jukebox source. It lets you read a selection of titles recorded in different albums or directories of Jukebox source.

Jukebox source can contain a maximum of 4 Playlists.

4- THE AUDIO/VIDEO AUXILIARY INPUT

The auxiliary input allows you to connect a nomad audio/video device directly to your NaviDrive. You connect your nomad audio device using the red connector **A** and the white connector **B**. You connect your nomad video device using the red connector **A**, the white connector **B** and the yellow connector **C** (See video chapter for functioning)

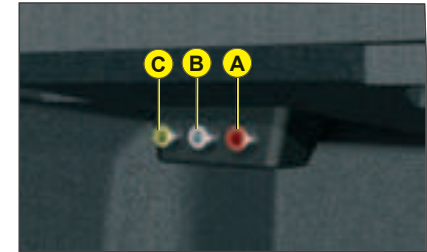

5- THE CD CHANGER SOURCE (ACCORDING TO EQUIPMENT)

See “CD changer source”.

IV



It is necessary to activate the audio/video auxiliary input before using this. See “Configuration”.

AUDIO GENERAL

HOW TO SELECT AN AUDIO SOURCE ?



Press button SOURCE.

HOW TO ADJUST THE SOUND VOLUME ?



or

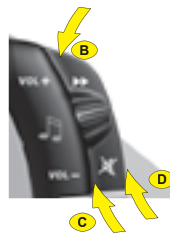

Rotate the control or use the buttons at the steering **B** and **C** to increase or decrease the volume.

How to stop the sound momentarily ?

Press on the Mute button **D**.

The sound of the Audio source currently being listened to is cut. The guidance instructions remain activated. To restore sound, press on one of the buttons on your NaviDrive, or on one of the controls on the steering wheel.

HOW TO ADJUST THE SOUND ?



Press on button **D** to select:

- the pre-defined musical ambiances,
- bass,
- treble,
- loudness,
- front/rear and left/right balance
- automatic correction of the volume as a function of vehicle speed.

Rotate the control to modify the value of the parameter displayed.

The value is automatically taken into account without the need for validation.



Selection of a pre-defined musical ambiance automatically adjusts bass and treble. Select the musical ambiance "None" to personalise your adjustment of bass and treble.



Adjustments of loudness, bass and treble (when they are available) are specific to each source.

The sound volume is automatically corrected as a function of vehicle speed, provided the facility has been activated.

AUDIO

ACCESSING THE MENU

HOW TO ACCESS THE AUDIO MENU ?

	<ul style="list-style-type: none">• Press button MENU.	
	<ul style="list-style-type: none">• Rotate the control to select the Audio icon A.• Press on the control to validate.	

IV

HOW TO ACCESS THE AUDIO MENU SHORTCUTS ?

When one of the Audio functions is displayed (successive presses on the MODE button), the shortcuts for the current source give you access to the principal functions (e.g. the Radio functions).

	<ul style="list-style-type: none">• Press on the control. A window opens.	
	<ul style="list-style-type: none">• Rotate the control to select your chosen option.• Press on the control to validate.	

The shortcut options available allow you:

- **B** Manually enter the frequency of a station.
- **C** To activate or deactivate RDS search.
- **D** To activate or deactivate regional search mode.
- **E** To activate or deactivate display of the text information broadcast by the station being listened to.



Each Audio source has a shortcut.

AUDIO

STRUCTURE OF THE MENU (1/2)

WHAT ARE THE FUNCTIONS OF THE AUDIO MENU ?

IV



A SETTING PARAMETERS FOR RADIO SOURCE

- A1 Manually enter the frequency of a station.
- A2 Activate or deactivate RDS search.
- A3 Activate or deactivate regional search mode.
- A4 To activate or deactivate display of the text information broadcast by the station being listened to (name of singer, title of song, etc.).



B SETTING PARAMETERS FOR CD AND JUKEBOX SOURCES

- B1 Activate or deactivate playback of the start of each track of the CD/CD MP3.
- B2 Activate or deactivate playback of all the tracks of the CD or of all the directory of the Jukebox.
- B3 Activate or deactivate repetition of the current album or CD-cover.
- B4 Activate or deactivate display of the information on the CD (Name of the album, artist, etc.).

C COPY OR STOP COPYING A CD OR A CD MP3

AUDIO

STRUCTURE OF THE MENU (2/2)

WHAT ARE THE FUNCTIONS OF THE AUDIO MENU ? (CONTINUED)

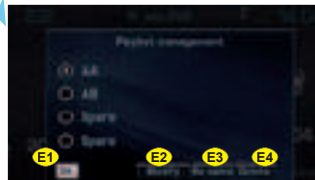
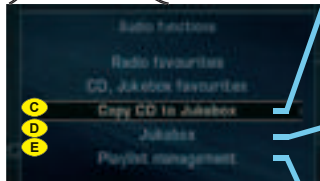

C COPYING A CD ONTO JUKEBOX SOURCE

- C1** Copy the whole of a CD.
- C2** Select several tracks and/or several albums to be copied.
- C3** Copy the current album (CD MP3 only).
- C4** Copy the current track.

D MANAGING AND SETTING PARAMETERS FOR JUKEBOX SOURCE

- D1** Move, delete or rename data stored on the hard disc or from Jukebox source (Albums, titles).
- D2** Define a compression rate in MP3.
- D3** Re-initialise Jukebox source.

E MANAGING THE PLAYLIST

- E1** Listen to the Playlist selected.
- E2** Select titles or albums in order to modify or create a Playlist.
- E3** Rename a Playlist.
- E4** Delete a Playlist.

HOW TO SELECT A WAVE BAND ?

IV



Press on button **BAND** to change successively through the memory banks:

- **FM1, FM2 and AM**: 2 FM wavebands and 1 AM wavebands for pre-setting the radio stations.
- **FMast** : the FM waveband dedicated to the stations memorised automatically (see Autostore function).

HOW TO SEARCH FOR A STATION AUTOMATICALLY ?

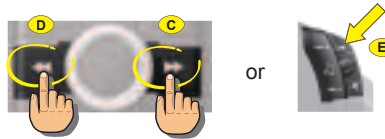

- Press on button **C** or on the control on the steering wheel **E** to increase the frequency.
- Press on button **D** to decrease the displayed frequency.

HOW TO RECALL PRE-SET STATIONS ?

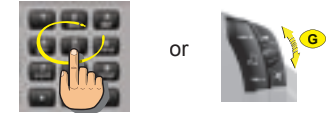

Press on one of the buttons **1** to **6** on the keypad and rotate the control **G** at the steering wheel.

For RDS stations, recall of a station launches a search for the frequency corresponding to the region you are in.

The frequency of the RDS station appears a few seconds before the station name.

HOW TO SEARCH FOR A STATION MANUALLY ?

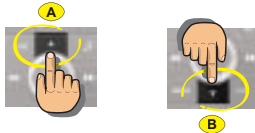

- Press on button **A** to increase the displayed frequency.
- Press on button **B** to decrease the displayed frequency.

HOW TO PRE-SET A STATION ?



Maintain pressure on one of the buttons **1** to **6** on the keypad for more than 2 seconds.

Note: A window opens on the screen. The station is memorised as it appears on the attributed memory number.

HOW TO BRING UP “RADIO TEXT” ?



Press on the control to view briefly the text information relating to the programme being listened to (name of artist, title, etc.).



Keep the buttons **A**, **B**, **C**, **D**, or **E** pressed to obtain a continuous scrolling of the frequency.

During an automatic search, if your NaviDrive does not manage to capture a station whose frequency you know, do a manual search.

HOW TO SEARCH FOR STATION IN A SORTED LIST ?

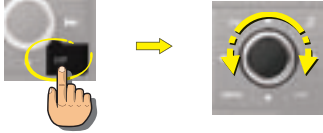

A list of the stations available locally is updated automatically every 10 minutes. The stations are graded alphabetically and then by frequency in ascending order.

- Press on button LIST to access the list of stations available.
- Rotate the control to choose a station.
- Press on the control to validate.

HOW TO MEMORISE TRANSMITTERS AUTOMATICALLY ?



In FM, keep button BAND pressed for more than 2 seconds to start the automatic memorisation function (Autostore).

The 6 strongest transmitters are memorised in the FMast memory bank. They replace the 6 previously memorised.

Note:

If you have activated the “TA” function (traffic information), the transmitters offering this service are memorised first.



Your NaviDrive may be subject to phenomena which you do not encounter with the installation you have at home.

Reception in AM as in FM is affected by various kinds of interference that have nothing to do with the quality of your equipment but are due to the nature of the signals and the way they are sent out.

In AM, you may notice disturbance when passing under high tension cables or bridges, or in tunnels.

In FM, distance from the transmitter, deflecting of the signal by obstacles (mountains, hills, high buildings, etc.), or blind spots (no coverage by transmitters) may cause interference with reception.



Keep button LIST pressed to update the list of stations available.

RADIO SOURCE

THE RDS SYSTEM

THE RDS FUNCTION ON FM WAVEBAND

IV

The RDS (Radio Data System) function allows you:

- to listen to the same station even though you are travelling through different regions (on condition that the transmitters for this station cover the area being travelled through),
- to listen to traffic announcement flashes on a temporary basis
- to have the station name displayed, etc.



The majority of FM stations use the RDS system.

These stations process non-audio data in addition to their programmes.

The data broadcast in this way gives you access to a variety of functions that are described in this chapter, notably the display of the station name, temporary traffic information flashes and automatic station search.

It allows to listen to the same station thanks to the frequency search. But RDS frequency search is not guaranteed over the whole country. The radio stations cannot cover the entire territory, which explains the loss of reception of the station during a journey.

REGIONAL SEARCH MODE

Certain stations are organised in a network.

In the various regions, they transmit programmes that are sometimes different, sometimes common.

You can do a search:

- On a regional station only
- On the entire network, with the possibility of hearing a different programme.



- **When the function is activated: your NaviDrive does not change from one regional station to another.**
- **When the function is deactivated: your NaviDrive selects the best frequency from among the regional stations.**

RDS STATION SEARCH

Your NaviDrive automatically checks and selects the best frequency for the radio station captured (provided the station transmits on more than one frequency).

The frequency of a radio station extends to around 50 km. Loss of reception during a journey is explained by the change from one frequency to another.

If the station you have selected does not broadcast on different frequencies in the areas in which you are travelling, it is possible to deactivate the automatic RDS transmission scanning function.



The display will indicate:

- **RDS while the function is activated and available.**
- **RDS shaded while the function is activated but not available for the station being listened to.**

RADIO SOURCE

TRAFFIC ANNOUNCEMENTS (TA)

THE TRAFFIC ANNOUNCEMENTS (TA) FUNCTION

The "TA" function lets you switch automatically on a temporary basis to an FM station broadcasting road information.

The radio station, or the audio source being listened to at that moment, is paused. Once the traffic information is finished, the system switches back to the radio station or audio source initially being listened to.



The display will indicate:

- TA provided the station is compatible.
- TA shaded if the station is not compatible.

HOW TO ACTIVATE THE "TA" FUNCTION ?



Press on the TA/PTY button to activate automatic broadcasting of traffic announcements.



If you activate the "TA" function, the transmitters compatible with broadcasting of these messages will be captured as priority during an automatic search or pre-setting of stations.

HOW TO STOP LISTENING TO A "TA" MESSAGE ?



Press on the TA/PTY button to stop listening to a message being broadcast.



In this case, the "TA" function remains activated.

HOW TO ADJUST THE VOLUME FOR TRAFFIC ANNOUNCEMENTS ?



or



During broadcasting of traffic announcements, the sound volume can be adjusted independently of the general radio volume.

Rotate the control wheel J or press on the controls at the steering wheel J and K to increase or decrease the volume.



The adjustment is automatically memorised.

CONDITIONS FOR RECEIVING TRAFFIC ANNOUNCEMENTS

- You have to be in FM.
- The station you are tuned to must confirm through the RDS system that it broadcasts road information.
- Stations organised in a network (EON) have regional transmitters sending their own programmes. While listening to one of these stations you can switch to any station on the network that is broadcasting traffic information messages.

RADIO SOURCE

PROGRAMME TYPES (PTY)

THE PROGRAMME TYPE MODE “PTY”

Certain stations allow you to choose to listen to a particular type of programme selected from the available list, for example as below:

- Information.
- Current affairs.
- Info-Services.
- Sport.
- Education.
- Fiction.
- Culture.
- Sciences.
- Entertainment.
- Pop music.
- Rock music.
- Folk music.
- Light classical.
- Classical music.
- Other music.
- Weather.
- Economy.
- Children.
- Social affairs.
- Religion.
- Line open.
- Travel.
- Leisure.
- Jazz.
- Country.
- Folk singing.
- Golden oldies.
- Traditional.
- Documentary.

HOW TO SELECT A PROGRAMME TYPE ?

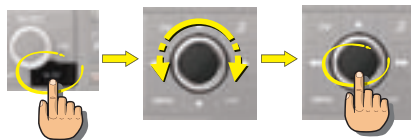

- Press on the **TA/PTY** button for more than 2 seconds to display the list of programme types.
- Rotate the control to choose a programme type.
- Press on the control to validate the programme type chosen.

HOW TO QUIT PTY MODE ?



Press on the **TA/PTY** button for more than 2 seconds.



Your NaviDrive launches a station search. It will tune to the first transmitter broadcasting this type of programme. If it does not find one, it will return to the original station and quit PTY mode.

SAFETY PRECAUTIONS

Do not operate the CD player if the temperature in the cabin is higher than +60°C or lower than -10 °C.

Some CDs are badly affected by very strong heat and may damage your CD player.

In excessive temperature, an automatic safety mechanism prevents the CD from operating until the temperature becomes more acceptable.

HANDLING OF CDs

- Do not drop them.
- Store the CDs so that they are kept of dust. Avoid touching the disc surface as any scratches may adversely affect the sound quality.
- Do not attach any stickers to the discs.
- Do not write on them.
- Do not use damaged or deformed discs.
- Do not expose them to heat or direct sunlight.



If the surface of the compact disc is dirty, it can be wiped with a soft, clean cloth. Always wipe from the centre of the disc outwards.

CD MP3

Format MP3 (MPEG 1,2 & 2,5 Audio Layer 3) is a compression norm for audio, allowing you to record 10 times as many musical files on one CD.

Your NaviDrive only reads files with the extension ".mp3". The other types of files (.wav, .mpg4, .ogg, midi, etc.) cannot be read.

When you insert a CD MP3, the radio searches all the musical tracks. Playback may require some tens of seconds before starting.

Playback of the CD MP3 is optimised if the cover level is limited to 2.

Burning format

Some cut CDs cannot be read by your equipment (quality, speed of recording, etc.).

When you burn a CD-R or CD-RW, select the burning standard ISO 9660 level 1,2 or Joliet. Playback of other formats may not occur correctly. Use the Joliet standard to burn multi-session CDs.

On a given CD, always use the same burning standard.

To obtain the best possible acoustic quality, select the lowest burning speed.

Transmission speeds of 8 to 320 kbits/s and bands of 22,05 to 44,1 kHz are accommodated.



After several months of use, it may be necessary to clean the lens of the CD player (with a cleaning CD) if the playback starts to become intermittent.



Your Audio equipment may enable you to listen to musical works. Musical work is protected by law. Non-respect of the law can lead to prosecutions.

HOW TO EJECT A CD/DVD MP3 ?



Press button **A**.
Your NaviDrive goes automatically to radio source.
If the CD is not removed within 10 to 15 seconds, it is automatically taken back into the slot but without being played back.

HOW TO SELECT A TRACK ?



- press button **B** to return to the start of the current track. A second press takes you back to the previous track.
- Press on button **C** or on the control at the steering wheel **D** to play the next track.

HOW TO PLAYBACK IN ACCELERATED SOUND



When you are listening to an audio CD:

- Keep button **B** pressed for rapid reverse with accelerated sound.
- Keep pressing button **C**, or the control on the steering wheel **D**, to listen in fast forward.

Release to resume normal playback of the disc.











Fast forward and rewind are not possible with a CD MP3.

JUKEBOX SOURCE

COPYING A CD/CD MP3 ONTO THE HARD DISC (1/2)

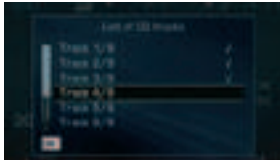
HOW TO COPY A CD ONTO JUKEBOX SOURCE ?

	<ul style="list-style-type: none">• Insert a CD/CD MP3 into the reader of your NaviDrive.	
	<p>In the Audio menu:</p> <ul style="list-style-type: none">• Rotate the control to select the menu A.• Press on the control to validate. <div data-bbox="215 333 1168 404" style="border: 1px solid black; background-color: #ffffcc; padding: 5px;"> Once the CD is inserted, you can press directly on the control to access the contextual menu to copy the CD.</div> <p>If you wish to copy:</p> <ul style="list-style-type: none">• the whole of the CD Rotate the control to select B• several tracks, rotate the control to select C• the current album (CD MP3 only), rotate the control to select D.• the track being listened to, rotate the control to select E <ul style="list-style-type: none">• Press on the control to validate.	
 	<p>If you select option C:</p> <ul style="list-style-type: none">• Rotate the control to select the context containing the list of tracks on the CD.• Press on the control to validate. <ul style="list-style-type: none">• Rotate the control to select a track.• Press on the control to select the track. <p>Once all the desired tracks have been selected, press on button ESC to exit from the context.</p> <ul style="list-style-type: none">• Rotate the control to select OK.• Press on the control to validate.	 
	<p>Jukebox source gives you the chance to:</p> <ul style="list-style-type: none">• create a personalised album F,• to create an album by default G.	

JUKEBOX SOURCE

COPYING A CD/CD MP3 ONTO THE HARD DISC (2/2)

IV

If you select option **E**, you have to name the album.

- Rotate the control to select the letters that make up the name of the album.
- Press on the control to validate each letter.

i You can select upper case, lower case or special characters by selecting the **G** option.



- Select the **H** option to correct the entry.

i If you copy a CD MP3 or *2 CDs containing CD text information, the names of the albums and tracks will be retained. The names of the ID3 Tags is retained and used if a CD MP3 is copied.

Once the entry is completed, rotate the control to select OK.

- Press on the control to validate. A warning about illegal copying of music is displayed.
- Press on the control to accept.



Copying is started.

i Jukebox source copies the CDs in 4x.
For example: a CD of 1 hour will be copied in 15 minutes.
During copying, the CD cannot be played back. Playback is again possible during compression. The other Audio sources remain available at any time.
If you copy a CD that is not in MP3 format, Jukebox source will itself compress the CD once the copying is completed. The compression rate in MP3 can be parametered (see Audio menu - Jukebox configuration). The compression time is added to the time taken by your system to copy the CD. (the copying time will be multiplied by 2).



An alert tells you that the copying of the CD is finished.

If it is not a CD MP3, Jukebox source compresses the CD automatically.









An alert tells you that the compressing of the CD is finished.

i At any time, you can stop the copying of the CD/CD MP3 by accessing the Audio main menu. The compression cannot be stopped. Stopping copying of CDs/CD MP3 does not delete the files already transferred onto the hard disc of Jukebox source.

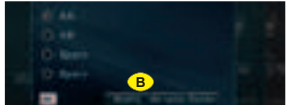
JUKEBOX SOURCE

CREATING A PLAYLIST

HOW TO CREATE A PLAYLIST ?

	<p>In the Audio menu:</p> <ul style="list-style-type: none">• Rotate the control to select the menu A.• Press on the control to validate.	
	<ul style="list-style-type: none">• Rotate the control to select an empty Playlist.• Press on the control to validate.	
	<ul style="list-style-type: none">• Rotate the control to select B.• Press on the control to validate.	
	<ul style="list-style-type: none">• Rotate the control to select an album.• Press on the control to validate.	
	<ul style="list-style-type: none">• Rotate the control to select tracks. <div data-bbox="209 585 1150 645" style="border: 1px solid black; background-color: #ffffcc; padding: 5px;"><p> The order of selection of the albums and tracks determines their order in the Playlist.</p></div> <ul style="list-style-type: none">• Press on the control to enter. <p>Once the selection is completed:</p> <ul style="list-style-type: none">• Rotate the control to select OK.• Press on the control to validate. <div data-bbox="209 814 1150 874" style="border: 1px solid black; background-color: #ffffcc; padding: 5px;"><p> Select the option C to rename the tracks of the album.</p></div> <ul style="list-style-type: none">• Repeat the operation until your Playlist is completed.	

IV





 You cannot copy Playlists (files Winamp or .M3U) onto the Jukebox source. You have to create Playlists directly on the Jukebox source.

JUKEBOX SOURCE



PLAYING BACK AN ALBUM / A PLAYLIST

HOW TO PLAY BACK AN ALBUM IN JUKEBOX SOURCE ?

IV

	<ul style="list-style-type: none">• Press several times on button SOURCE until you obtain Jukebox source. <p>i Playback starts automatically on the last album played.</p>	
 	<p>To select another album, press on the buttons on the panel. You can also use the control on the steering wheel.</p> <p>i To select an album in Jukebox source from a list, press on button LIST. A window opens on a list of all the albums in Jukebox source.</p>	
	<ul style="list-style-type: none">• Rotate the control to select an initial track.• Press on the control to validate. <p>i Playback of the album commences automatically.</p>	

HOW TO PLAY BACK A PLAYLIST ?

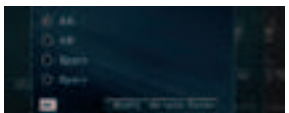
	<p>In the Audio menu:</p> <ul style="list-style-type: none">• Rotate the control to select the menu A.• Press on the control to validate.	
	<ul style="list-style-type: none">• Rotate the control to select a Playlist.• Press on the control to validate.• Rotate the control to select OK.• Press on the control to validate. <p>i Playback of the Playlist commences automatically.</p>	

i To stop playback of a Playlist, press on the control to access the contextual menu.

CD CHANGER SOURCE (ACCORDING TO EQUIPMENT)

WHAT IS THE CD CHANGER ?



CD CHANGER SOURCE

This device can accommodate 5 discs.

INSERTING CDs INTO THE MAGAZINE

Insert the CDs printed surface to the left.

Note:

- Each compartment takes one disc only.
- The CD changer will not operate if discs are inserted the wrong way up.

REMOVING DISCS

To remove a CD, give a long press on the corresponding button **A**.

SELECTING CD CHANGER SOURCE

Press successively on button **24**, until the desired source is obtained.

SELECTING A CD



Hold down one of the buttons **1** to **5** on the alphanumeric keypad to choose the CD that you wish to play back.

PLAY BACK THE NEXT/PREVIOUS CD

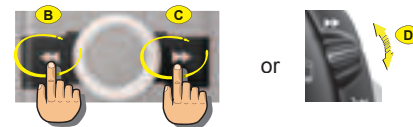

1. Press on button **C** or rotate the control on the steering wheel **D** upwards to listen to the next CD.
2. Press on button **B** or rotate the control on the steering wheel **D** downwards to listen to the previous CD.

Note: Playback of the start of the CD is automatic.

After each change of source, on return to CD changer source, playback will resume at the same point where it had been interrupted.

TELEPHONE

GENERAL

WHAT IS THE TELEPHONE FUNCTION ?

V

The telephone function consists of a GSM telephone incorporated in NaviDrive.

It has a "Hands-free" function, provided by a microphone located in the front interior lamp and controls at the steering wheel for accessing the majority of operations.



Do not allow yourself to be distracted while you are driving.

It is essential to comply with the national legislation in force.

Stop the vehicle if you wish to pursue a telephone conversation or proceed with certain actions (composing a number for example).



As with any mobile telephone, this telephone operates thanks to both cellular and terrestrial networks. For this reason, it cannot guarantee a connection in all cases.

THE MULTIFUNCTION SCREEN



Apart from during a communication, it indicates to you:

- the presence of voice messages or text messages (SMS) that have not been read,
- the communication time since the last update,
- the level of reception of the networks.

During a communication, it indicates to you:

- the time elapsed since the start of the communication,
- the number (provided the option and the service are available),
- the name of your correspondent (if this is recorded in the directory),
- the level of reception of the network.

THE ALPHANUMERIC KEYPAD

Each press on one of the keypad buttons lets you scroll through the characters which are allocated on it.

Button	Selection
[1]	1 or space with a short press in text entry (SMS)
[2]	2 or ABC or abc
[3]	3 or DEF or def
[4]	4 or GHI or ghi
[5]	5 or JKL or jkl
[6]	6 or MNO or mno
[7]	7 or PQRS or pqrs
[8]	8 or TUV or tuv
[9]	9 or WXYZ or wxyz
[0]	In text entry (SMS): <ul style="list-style-type: none">• Short press: Space or 0• Long press: Space In dialling: <ul style="list-style-type: none">• Short press: 0• Long press: +
[#]	In dialling: <ul style="list-style-type: none">• Short press: #
[*]	In text entry (SMS): <ul style="list-style-type: none">• Short press: Deletion of last character• Long press: Progressive deletion of the entire line In dialling: <ul style="list-style-type: none">• Short press: *• Long press: Deletion of last character



You can use the keypad to do a rapid search for a name in the directory and in the SIM card.

TELEPHONE

GENERAL

HOW TO INSTALL AND REMOVE THE SIM CARD ?

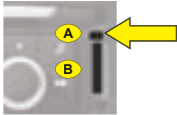

Press on control **A** with a ballpoint to eject the support **B**.

Place the SIM card on the support **B**.
Insert the support **B**.

Note:

- Switch off the NaviDrive before removing the SIM card (key in position **S** (Steering lock) and display off).
- The card has to be present in order for certain functions to work properly.

RECOMMENDATION FOR INSTALLING A TWIN SIM CARD

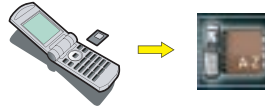

Depending on countries and operators, you may be able to benefit from having 2 SIM cards at a discounted rate. These 2 cards have the same call number and the same messaging. Calls arrive as priority on your principal line. If the telephone containing the principal SIM card is switched off, the calls are transferred automatically to the equipment with the second SIM card.

On first installation or for updating your directory:

- Insert the SIM card from your mobile telephone.
- Transfer the information to the directory of your NaviDrive.
- Insert the twin SIM card.

HOW TO ENTER THE PIN CODE ?

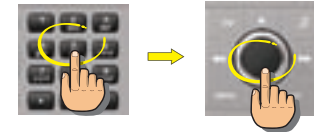

- Enter the **PIN** code on the keypad.
- Rotate the control to select OK.
- Press on the control to validate.



Your NaviDrive can definitively memorise the PIN code of a SIM card. Once the memorisation is accepted, your PIN code will only be requested the first time you do an entry.



Your SIM card has to be valid.
Before starting a call, make sure that you are in an area covered by your telephone operator.



This transfer necessitates a callback (consult your telephone service operator).

For the services to operate at their best, it is recommended to have the principal SIM card inserted in your NaviDrive.

HOW TO DEBLOCK THE TELEPHONE ?

After three entry errors, the telephone will be blocked.

Enter your PUK code to deblock the telephone.

Note: The PUK code is supplied by the vendor of your SIM card. The entering of the PUK code tolerates 10 errors in succession. After that, the SIM card will be definitively unusable.



Contact your telephone operator.

TELEPHONE

ACCESSING THE MENU



HOW TO ACCESS THE TELEPHONE MENU ?

V

	<ul style="list-style-type: none">• Press button MENU.	
	<ul style="list-style-type: none">• Rotate the control to select the Telematics icon A.• Press on the control to validate.	

HOW TO ACCESS THE TELEPHONE MENU SHORTCUTS ?

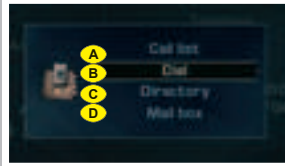
When the telephone function is displayed (in the Telephone menu giving access to the main functions for the telephone and telematic services).

	<ul style="list-style-type: none">• Press on the control. A window opens.	
	<ul style="list-style-type: none">• Rotate the control to select the option of your choice.• Press on the control to validate.	

The shortcut options available allow you:

- A** to access the Calls list
- B** to compose a number
- C** to access the directory
- D** to access your voice mail (GSM operator messaging).



In the directory, there are 2 groupings of memorised numbers accessible:

- the numbers in the current directory of your NaviDrive,
- the numbers in the SIM card.

The numbers contained in the SIM card are preceded by a “SIM card” symbol.

TELEPHONE MENU STRUCTURE

WHAT ARE THE FUNCTIONS OF THE TELEMATICS MENU ?

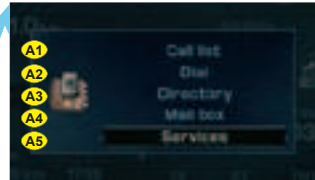
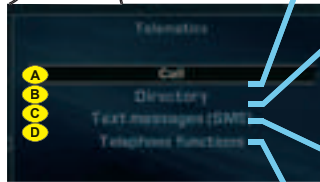

A MAKING A TELEPHONE CALL

- A1 Consult the list of incoming, outgoing and missed calls.
- A2 Compose a telephone number on the numeric keypad.
- A3 Select a file in the directory.
- A4 Consult your voice mail.
- A5 Select one of the CITROËN network services (depending on subscription).

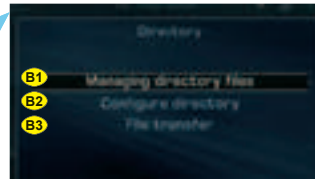

B OPERATING THE TELEPHONE DIRECTORY

- B1 Consult, modify, create or delete a directory file.
- B2 Select or name a directory. Choose the start directory.
- B3 Send or receive one or more files by infrared or from the SIM card.



C READING, SENDING, EDITING OR DELETING AN SMS MESSAGE

- C1 Read SMS messages received or stored.
- C2 Send a stored SMS.
- C3 Drafting an SMS.
- C4 Delete all stored SMS messages.

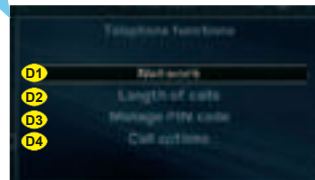

D SETTING PARAMETERS FOR THE TELEPHONE FUNCTIONS







- D1 Configure the network search mode or consult the networks available.
- D2 Consult the length of one or all of the incoming or outgoing calls. Reset the counter to zero.
- D3 Activate, deactivate, memorise or modify the PIN code.
- D4 Configure the displaying of the number, the automatic pick up, the ring tone and the call return. Delete the log of calls.

TELEPHONE







MAKING A CALL

HOW TO MAKE A CALL ?

V

	<ul style="list-style-type: none">• Press the “Pick-up” button or press the control on the steering wheel.	 
	in the Telephone menu: <ul style="list-style-type: none">• Rotate the control to select the menu A.• Press on the control to validate.	
	<ul style="list-style-type: none">• Compose the number of the person you wish to call on the alphanumeric keypad.	
	<ul style="list-style-type: none">• Press the “Pick-up” button or press the control on the steering wheel.	
	<ul style="list-style-type: none">• To end the call, press the “Hang-up” button or press the control on the steering wheel.	







HOW TO ACCEPT/REFUSE A CALL ?

	When you receive a call:	
	<ul style="list-style-type: none">• Press the “Pick-up” button to accept the call or press the control on the steering wheel. or in the Telephone menu: <ul style="list-style-type: none">• Rotate the control to select B.• Press on the control to validate.	
	To refuse the call:	
	<ul style="list-style-type: none">• Press the “Hang-up” button or give a long press on the control on the steering wheel. or	
	<ul style="list-style-type: none">• Rotate the control to select C.• Press on the control to validate.	

TELEPHONE

DRAFTING AN SMS

HOW TO DRAFT AN SMS ?

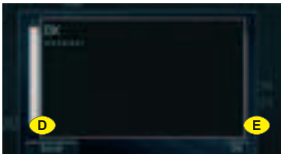
	<ul style="list-style-type: none">• Rotate the control to select the menu A.• Press on the control to validate. <p>• Rotate the control to select the letters to make up the message.</p> <p>• Press on the control to validate each letter.</p> <div data-bbox="220 350 1169 412" style="border: 1px solid black; background-color: #ffffcc; padding: 5px;"><p> You can select upper case, lower case or special characters by selecting the B option.</p></div> <ul style="list-style-type: none">• Select the C option to correct the entry. <p>Once the message is complete:</p> <ul style="list-style-type: none">• Rotate the control to select OK.• Press on the control to validate.	 
	<p>A window opens. You can view the content of your SMS.</p> <ul style="list-style-type: none">• Rotate the control to select OK.• Press on the control to validate. <ul style="list-style-type: none">• Compose the number of your correspondent on the alphanumeric keypad, select a file in your directory or access the log of calls.• Rotate the control to select the D option.• Press on the control to validate. The message is sent. <div data-bbox="220 779 1169 838" style="border: 1px solid black; background-color: #ffffcc; padding: 5px;"><p> You can defer sending the SMS by storing it E.</p></div>	

On receiving an SMS

A sound signal and a superimposed window announce the arrival of a new SMS:

- Select YES to read the SMS.
- Select NO to store the SMS without reading it.

You can reply directly to an SMS or record the number of the sender.

V

TELEPHONE TELEMATIC SERVICES

V



CITROËN EMERGENCY

To benefit from the localised emergency service with vehicle location, you have:

- to have signed the general conditions of the service stated on your vehicle order form, or have signed the specific CITROËN Emergency Contract,
- to have made an initial call to the CITROËN Emergency service.

To initialise this service:

- press on the SOS button, with the vehicle stationary and parked in the open air in an area covered by your mobile telephone operator,
- be prepared to refer to your registration document,
- specify to the operator that you are making a "CITROËN Emergency service initialisation" call.

When should you use this service ?

In an emergency situation (accident with injuries, assault, etc.).

How to access this service ?

Press on the SOS button of your NaviDrive. You are put in contact with our specialised assistance platform. An operator will rapidly assess the situation and if necessary send help to the spot.

Your vehicle is automatically located thanks to the GPS function of your NaviDrive.



Any call to this service must be motivated by an actual situation of serious emergency.

Automatic triggering of the emergency call

If there is a deployment of the pyrotechnic components on your vehicle, the NaviDrive will automatically transmit an emergency call to our specialised assistance platform (given no atmospheric, topographical or technical restrictions in the country you are in, as stipulated in the general conditions of the CITROËN Emergency service).

Should there be no response from the persons present in the vehicle, assistance will systematically be sent to the location of the incident. To gain time, your vehicle is located automatically thanks to the GPS function of the NaviDrive system.

Note: In the absence of a subscription to the CITROËN Emergency service or if there is no service in the country concerned, the SOS button is set to trigger a call to 112, a unique number reserved for emergency calls by the European GSM network. However, you will not then be geographically located. Depending on country, the call to 112 can be made without the need for a SIM card to be present in the system.



If you have made an error, to cancel the call being made, press on the SOS button for 8 seconds. You have 6 seconds to cancel.



To be able to activate this service and in order to be aware of the detailed conditions for its use and operation, refer to the general conditions of the CITROËN Emergency service.

This service is only accessible if there is a subscription to the CITROËN Emergency service and is dependent on availability.

At the end of 2006, the service is available in France, Germany, Italy, Benelux, Spain and Portugal. The service is due to be extended to other countries, details of which can be obtained from a member of the CITROËN network.



HOW DOES THE CITROËN EMERGENCY SERVICE OPERATE ABROAD ?

If the service is available in the country you are travelling to, the emergency call will be connected and an operator will respond in the language of your country (provided the operator of the SIM card inserted in the NaviDrive is indeed that of your country).

TELEPHONE

TELEMATIC SERVICES



CITROËN ASSISTANCE

When should you use this service ?

If your vehicle malfunctions (mechanical breakdown), this service puts you in contact with our CITROËN Assistance platform to request a recovery vehicle.

Note: While making an assistance call, it is impossible to make other calls apart from an emergency call.

How to access this service ?

- Keep the CITROËN button pressed.

Or

- Press button CITROËN.
- Select the CITROËN Assistance menu.
- Validate.



Provided you have subscribed to the CITROËN Emergency service and the service is available in your country, our assistance vehicles will easily be able to locate your vehicle and check your position with you.

This service can only be accessed if there is a subscription to the CITROËN Assistance service, subject to availability in the country concerned.

CITROËN ON LINE

When should you use this service ?

CITROËN On Line puts you in contact with specialised operators who can answer questions about use of your NaviDrive and the associated services offered by the manufacturer and its dealer networks.

How to access this service ?

- Press button CITROËN.
- Select the CITROËN On Line menu.
- Validate.



This service operates only in France from end 2006.



The reserve battery enables you to make an emergency call even if the vehicle battery is disconnected.

The battery has a life of 4 years. It must be disposed of by a specialist operator, never thrown into the public refuse.

It is essential to be familiar with, and comply with, the legislation in force.

NAVIDRIVE SERVICES

When should you use this service ?

This menu gives you access to the basket of telematic services offered by CITROËN (construction of an optimised itinerary, sending of a destination, search for a point of interest, a restaurant, search for an individual or professional in directory enquiries, etc.) depending on availability in the country concerned and on there being a subscription to the services.

How to access this service ?

- Press button CITROËN.
- Select the menu for NaviDrive Services.
- Validate.



The NaviDrive Services symbol will only appear if there is a subscription to the services and provided they are available.



Subject to a subscription to the services and to availability in the country concerned.

MESSAGES RECEIVED

To read the messages relating to the benefits offered by your specific Service Contract.

V

CONFIGURATION

ACCESSING THE MENU - STRUCTURE

WHAT IS THE CONFIGURATION MENU ?

VI The Configuration menu enables you to programme your NaviDrive as well as certain functions of your vehicle.

HOW TO ACCESS THE CONFIGURATION MENU ?



- Press button MENU.
- Rotate the control to select the Configuration icon.
- Press on the control to validate.

WHAT ARE THE FUNCTIONS OF THE CONFIGURATION MENU ?

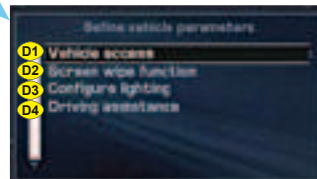

A CONFIGURING THE DISPLAY OF YOUR NAVIDRIVE

- A1** Choose the colour of the display.
- A2** Adjust the brightness of the display.
- A3** Adjust the date and the time and define the format 12H or 24H.
- A4** Choose system of measurement: metric or imperial.

B CONFIGURE THE VOICE OF YOUR NAVIDRIVE

- B1** Activate or deactivate the voice commands.
- B2** Choose a feminine voice or a masculine voice and adjust the voice synthesiser volume.
- B3** Activate or deactivate the audio/video auxiliary input.

C CHOOSE THE LANGUAGE OF THE VOICE SYNTHESISER AND OF THE DISPLAY







D DEFINE THE VEHICLE PARAMETERS (ACCORDING TO EQUIPMENT)

- D1** To select unlocking of all the doors or only that of the driver's door.
- D2** Activate or deactivate the automatic triggering of the rear wiper when you engage reverse gear.
- D3** Choose the duration for guide-me-home lighting and activate or deactivate the directional headlamps.
- D4** Activate or deactivate the automatic engagement of the electric parking brake and access the configuration button.

CONFIGURATION

ADJUSTING THE DATE AND THE TIME

HOW TO ADJUST THE DATE AND THE TIME ?

	<p>In the configuration menu:</p> <ul style="list-style-type: none"> • Rotate the control to select the menu A. • Press on the control to validate. 	
	<ul style="list-style-type: none"> • Rotate the control to select the menu B. • Press on the control to validate. 	
	<p>Rotate the control to select a field:</p> <ul style="list-style-type: none"> - C for the day - D for the month - E for the year - F for the time. <ul style="list-style-type: none"> • Press on the control to validate. • Rotate the control or use the alphanumeric keypad to select the digits that make up the date and the time. • Press on the control to validate each field. 	
	<p>Rotate the control to select:</p> <ul style="list-style-type: none"> - G for 12 hour mode. - H for 24 hour mode. - I for an automatic adjustment of minutes thanks to GPS. <ul style="list-style-type: none"> • Press on the control to validate. 	



VEHICLE DIAGNOSIS MENU STRUCTURE

WHAT IS THE VEHICLE DIAGNOSIS MENU ?

VII

The vehicle diagnosis menu accesses the latest alerts that have been signalled as well as the status of the various functions on the vehicle.

HOW TO ACCESS THE VEHICLE DIAGNOSIS MENU ?

	<ul style="list-style-type: none">• Press button MENU.	
	<ul style="list-style-type: none">• Rotate the control to select the Vehicle Diagnosis icon A.• Press on the control to validate.	

WHAT ARE THE FUNCTIONS OF THE VEHICLE DIAGNOSIS MENU ?

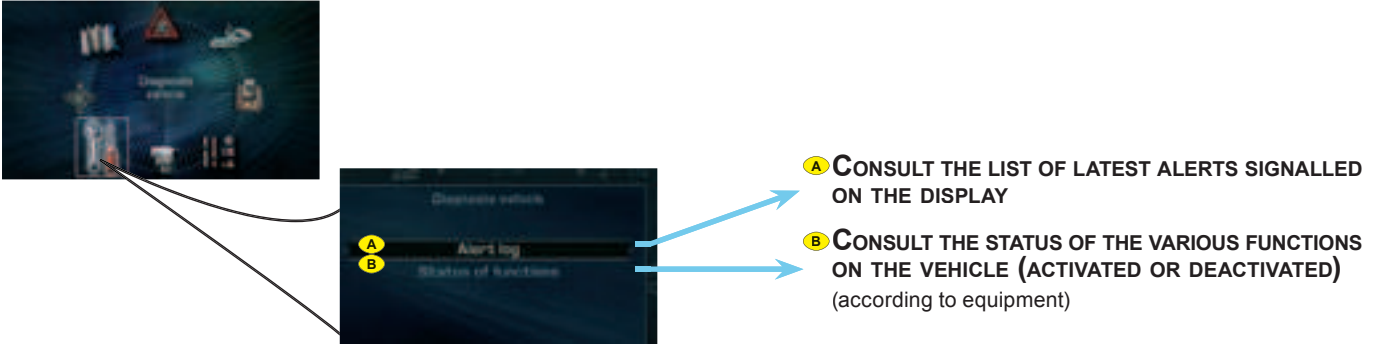

A CONSULT THE LIST OF LATEST ALERTS SIGNALLED ON THE DISPLAY

B CONSULT THE STATUS OF THE VARIOUS FUNCTIONS ON THE VEHICLE (ACTIVATED OR DEACTIVATED) (according to equipment)

VIDEO

ACCESSING THE MENU - STRUCTURE

WHAT IS THE VIDEO MENU ?

The Video menu comprises the functions for adjusting the video on your NaviDrive.

HOW TO ACCESS THE VIDEO MENU ?

	<ul style="list-style-type: none">• Press button MENU.	
	<ul style="list-style-type: none">• Rotate the control to select the Video icon A.• Press on the control to validate.	

WHAT ARE THE FUNCTIONS OF THE VIDEO MENU ?

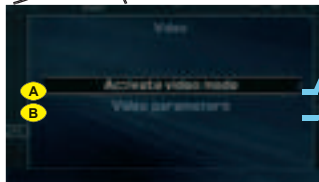

A ACTIVATING OR DEACTIVATING VIDEO MODE



If you have equipment connected on the audio/video sockets, activation of video mode cuts the audio source currently being listened to. Press on button SOURCE to reactivate any other audio source.

To view the images, the equipment has to emit a signal and the vehicle must be stationary. While the vehicle is in motion, only the sound is available.

B SETTING THE VIDEO PARAMETERS

- B1** Select a display format (16/9 or 4/3).
- B2** Adjust the brightness of the display.
- B3** Adjust the colour on the display.
- B4** Adjust the contrast on the display.



To use this source, activate the video mode. The video can be used if the vehicle speed is less than 5 km/h.

FREQUENTLY-ASKED QUESTIONS

The table below brings together the answers to the questions that are the most frequently asked.

QUESTIONS	ANSWERS	SOLUTIONS
There is a discrepancy in sound quality between the different audio sources (radio, CD, CD changer etc.).	To achieve an optimum listening quality, the audio adjustments (Volume, Bass, Treble, Ambiance, Loudness) can be adapted to each of the different sound sources, which can produce audible shifts when you change the source (radio, CD, CD changer etc.).	Check that the AUDIO adjustments (Volume, Bass, Treble, Ambiance and Loudness) are adapted to your wishes for each of the audio sources.
The CD immediately ejects.	The CD is the wrong way up, is unplayable, does not contain audio data or contains an audio format that the radio cannot play back.	Check that you have inserted the CD the right way up in the CD player.
		Check the condition of the CD: the CD cannot be played back if it is too damaged.
		Check the contents if it is a burnt CD: refer to the advice given in the chapter on Audio System.
		For reasons of poor quality, some burnt CDs will not be played back by the audio system.
		The CD changer does not play back DVDs.
The CD changer does not play back MP3 CDs.		
The CD player sound is downgraded.	The CD is scratched or of poor quality.	Insert only CDs of good quality and keep them in good condition.
The pre-set stations do not work (no sound, 87,5 Mhz is displayed, etc.).	The waveband selected is not the correct one.	Press on the BAND button to retrieve the waveband (AM, FM1, FM2, FMAST) where the stations are memorised.
Traffic Announcements (TA) is displayed. I do not receive any traffic information or public announcements.	The particular radio station is not in the regional traffic information network.	Change to a radio station that does broadcast traffic information.

FREQUENTLY-ASKED QUESTIONS

QUESTIONS	ANSWERS	SOLUTIONS
<p>The reception quality of the radio station being listened to gradually deteriorates.</p>	<p>The vehicle is too distant from the transmitter, or no transmitter is present in the geographical area you are passing through.</p>	<p>Activate the RDS function to allow the system to check whether a more powerful transmitter is to be found in the geographical area.</p>
	<p>The environment (hills, high buildings, tunnels, underground car parks, etc.) is blocking reception, even in RDS mode.</p>	<p>This phenomenon is normal and does not imply anything wrong with the radio.</p>
	<p>The aerial is absent or has been damaged (for example after going through a car wash or in an underground car park).</p>	<p>Have the aerial checked by a CITROËN dealer.</p>
<p>When the engine is not running, the radio stops after a few minutes.</p>	<p>When the engine is switched off, the working time for the radio depends on the battery charge. The interruption is normal: the radio goes into economy mode, cutting off in order to save the vehicle's battery.</p>	<p>You have to start the engine so as to increase the battery charge.</p>
<p>The message "the audio system is overheating" appears on the screen.</p>	<p>In order to protect the audio equipment in excessive ambient temperatures, the radio goes into an automatic thermic protection mode which results in a reduction in sound volume or stopping of the CD player.</p>	<p>Switch off the audio system for a few minutes in order to allow the system to cool down.</p>
<p>Why is one not informed in real time of a hold-up on the route even though the option for guidance by "traffic info" is activated ?</p>	<p>When you start up, the system takes a few minutes to capture the traffic information via RDS-TMC.</p>	<p>Wait for the traffic information to be safely received (pictogrammes displayed on the map) and make sure that you use the major arterial roads to have "informed" navigation.</p>
	<p>Only the major arterial roads (motorways and some dual carriageways) are featured in RDS-TMC traffic information).</p>	
	<p>It may happen that a hold-up is not reported by the traffic info provider.</p>	
<p>Why is a diversion not suggested when I have selected traffic info ?</p>	<p>Do not confuse the "traffic info" guidance option which can suggest a diversion (the "divert" button appears in the window) with the menu "Display of traffic messages" or "Reading of traffic messages" which affect only the display without recalculating the itinerary (no "divert" button in the window).</p>	<p>To have "informed" navigation with the detour proposition, it is essential to activate the guidance option with "traffic info".</p>