

Rider's Manual (US Model)

F 800 S



BMW Motorrad



The Ultimate Riding
Machine

Motorcycle/Retailer Data

Motorcycle data

Model

Vehicle Identification Number

Color number

First registration

Registration number

Retailer Data

Contact in Service

Ms./Mr.

Phone number

Retailer's address/phone number (company stamp)

Welcome to BMW

We congratulate you on your choice of a motorcycle from BMW and welcome you to the community of BMW riders.

Familiarize yourself with your new motorcycle so that you can ride it safely and confidently in all traffic situations.

Please read this Rider's Manual carefully before starting to use your new BMW motorcycle. It contains important information on how to operate the controls and how to make the best possible use of all your BMW's technical features.

In addition, it contains information on maintenance and care to help you maintain your motorcycle's reliability and safety, as well as its value.

If you have any questions concerning your motorcycle, your authorized BMW Motorrad retailer

is always happy to provide advice and assistance.

We wish you many miles of safe and enjoyable riding

BMW Motorrad.

Table of Contents

You can also use the index at the end of this Rider's Manual to find a specific topic.

1 General instructions 5

Overview	6
Abbreviations and symbols.....	6
Equipment	6
Technical data	7
Currentness of this manual....	7

2 Overviews 9

General view, left side.....	11
General view, right side	13
Underneath seat	14
Under battery compartment cover	15
Left handlebar fitting	16
Handlebar fitting, right.....	17
Instrument cluster	18
Headlight	19

3 Status indicators 21

Standard displays	22
Displays with onboard computer ^{OE}	23
Displays with Tire Pressure Control TPC ^{OE}	24
Standard warning indicators.....	24
Warning indicators of onboard computer (OE).....	29
ABS displays ^{OE}	29
TPC displays ^{OE}	32
Anti-theft alarm warning indicators (OE)	35

4 Operation..... 37

Ignition switch and steering lock	38
Electronic immobilizer	39
Clock.....	40
Odometer and tripmeters	40
Onboard computer ^{OE}	41
Tire Pressure Control TPC ^{OE}	46
Lights	46

Turn indicators	47
Hazard warning flashers	48
Emergency ON/OFF switch	50
Heated hand grips ^{OE}	50
Clutch	51
Brakes	51
Mirrors	52
Spring preload	52
Damping	53
Tires	54
Headlight.....	55
Seat.....	56
Helmet holder.....	56

5 Riding..... 59

Safety instructions	60
Checklist	61
Starting.....	62
Running in	64
Brakes	65
Parking your motorcycle	66
Refueling.....	68

6 Technology in detail ...	71	Rear-wheel stand	103	Brakes	126
Brake system with BMW Motorrad ABS ^{OE}	72	Lamps.....	104	Wheels and tires	126
Tire Pressure Control TPC ^{OE}	74	Jump-starting	110	Electrical system	129
7 Accessories	75	Battery	111	Frame	130
General instructions	76	9 Care	115	Dimensions	131
Onboard socket	76	Care products	116	Weights	132
Luggage	77	Washing your motorcycle.....	116	Riding specifications	132
Case ^{OA}	78	Cleaning sensitive motorcycle parts.....	116	11 Service	133
Topcase ^{OA}	81	Paint care	117	BMW Motorrad Service	134
8 Maintenance	85	Protective wax coating	118	BMW Motorrad Service Quality	134
General instructions	86	Storing motorcycle	118	BMW Motorrad Service Card - On-the-spot breakdown assistance	134
Onboard-toolkit service set	86	Returning motorcycle to use	118	BMW Motorrad Service Network	135
Engine oil	87	10 Technical data	119	Maintenance work.....	135
General brake system	88	Troubleshooting chart.....	120	Confirmation of maintenance work.....	136
Brake pads	89	Threaded fasteners	121	Confirmation of service.....	141
Brake fluid.....	91	Engine	122	Reporting	
Coolant.....	93	Fuel	123	Safety Defects.....	148
Clutch.....	94	Engine oil	123		
Tires	95	Clutch	124		
Rims	95	Transmission	124		
Wheels	95	Rear-wheel drive	125		
Front wheel stand	102	Running gear.....	125		

General instructions

Overview	6
Abbreviations and symbols	6
Equipment	6
Technical data	7
Currentness of this manual	7

Overview

Chapter 2 of this Rider's Manual will provide you with an initial overview of your motorcycle. All maintenance and repair work carried out on your motorcycle will be documented in Chapter 10. Proof of the maintenance work performed is a prerequisite for generous treatment of claims. When the time comes to sell your BMW, please remember to hand over this Rider's Manual; it is an important part of the motorcycle.

Abbreviations and symbols



Indicates warnings that you must comply with for reasons of your safety and the safety of others, and to protect your motorcycle against damage.



Special information on operating and inspecting your motorcycle as well as maintenance and adjustment procedures.



Indicates the end of an item of information.



Instruction.



Result of an activity.



Reference to a page with more detailed information.



Indicates the end of accessory or equipment-dependent information.



Tightening torque.



Technical data.

OE Optional equipment
The motorcycles are assembled complete with all the BMW optional extras originally ordered.

OA Optional accessories
BMW optional accessories can be purchased and installed at your authorized BMW Motorrad retailer.

EWS Electronic immobilizer.

DWA Anti-theft alarm.

ABS Anti-Lock Brake System.

TPC Tire Pressure Control.

Equipment

When you ordered your BMW motorcycle, you chose various items of custom equipment. This Rider's Manual describes optional equipment (OE) offered by BMW

and selected optional accessories (OA). This explains why the manual may also contain descriptions of equipment which you have not ordered. Please note, too, that your motorcycle might not be exactly as illustrated in this manual on account of country-specific differences.

If your BMW is equipped with options or accessories not described in this Rider's Manual, then this equipment is described in a separate operating manual.

Technical data

All dimensions, weights and outputs in the Rider's Manual refer to the Deutsche Institut für Normung e. V. (DIN) and comply with its tolerance regulations. Versions for individual countries may differ.

Currentness of this manual



The high safety and quality standards of BMW motorcycles are maintained by constant development work on designs, equipment and accessories. Because of this, your motorcycle may differ from the information supplied in the Rider's Manual. In addition, BMW Motorrad cannot guarantee the total absence of errors. We hope you will appreciate that no claims can be entertained on the basis of the data, illustrations or descriptions in this manual.

Overviews

General view, left side.....	11
General view, right side	13
Underneath seat	14
Under battery compartment cover	15
Left handlebar fitting	16
Handlebar fitting, right	17
Instrument cluster	18
Headlight	19



General view, left side

- 1 Adjusting headlight range
(below instrument cluster)
( 55)
- 2 Seat lock ( 56)
- 3 Engine oil fill location and oil
dipstick ( 87)



General view, right side

- 1 Fuel filler opening (→ 68)
- 2 Brake-fluid reservoir, front (→ 91)
- 3 Coolant level indicator (→ 93)
- 4 Onboard socket (→ 76)
- 5 Adjuster for spring preload, rear (→ 52)
- 6 Brake-fluid reservoir, rear (→ 92)
- 7 Adjustment of rear damping (→ 53)

Underneath seat

- 1 Table of tire pressures
- 2 Torx 25/Phillips screwdriver blade
- 3 Screwdriver handle
- 4 Rider's Manual (US Model)
- 5 Helmet holder (➔ 56)
- 6 Location for first-aid kit (OA)
- 7 Onboard-toolkit service set (➔ 86)
- 8 Tools for adjusting spring preload (➔ 52)

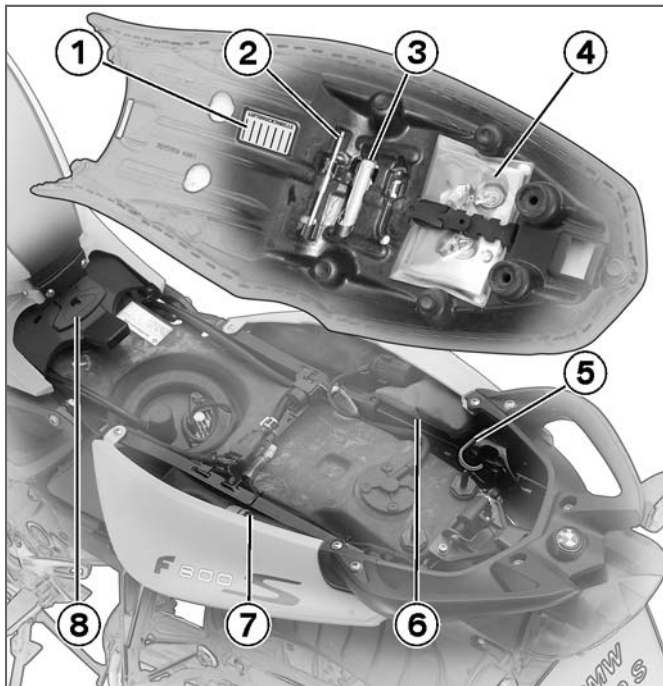

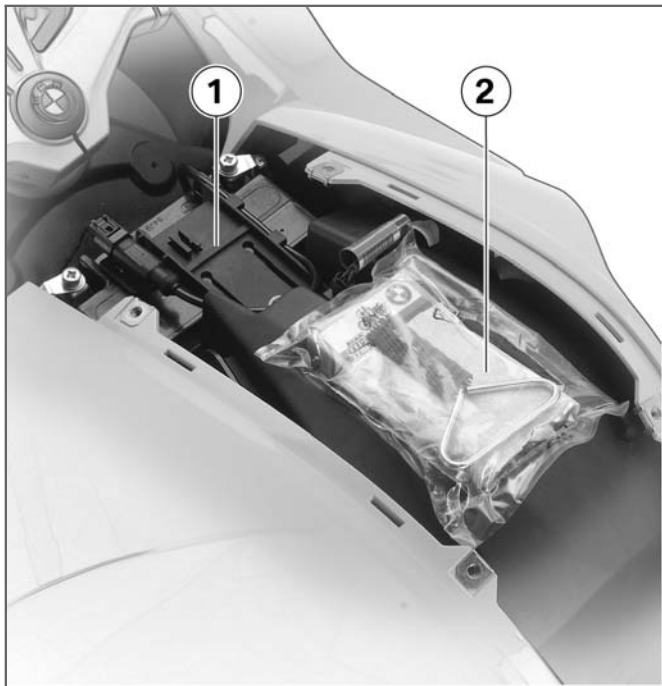

Under battery compartment cover

- 1 Battery (➔ 111)
- 2 Location for flat tire set (OA)

Left handlebar fitting

- 1 Operating onboard computer^{OE} (→ 41)
- 2 Horn
- 3 Flashing turn indicators, left (→ 47), Hazard warning flashers (→ 48)
- 4 High-beam headlight and headlight flasher (→ 47)

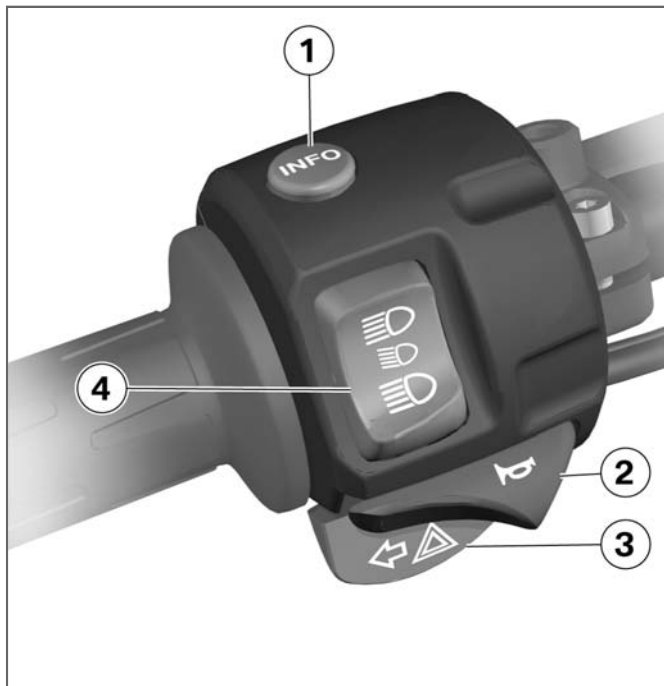



Handlebar fitting, right

- 1 Emergency ON/OFF switch (➡ 50)
- 2 Starter button (➡ 62)
- 3 Heated hand grips^{OE} (➡ 50)
- 4 Flashing turn indicators, right (➡ 48), Hazard warning flashers (➡ 48)
- 5 Turn indicators off (➡ 48), Hazard warning flashers off (➡ 49)

Instrument cluster

- 1 Indicator lights (➡ 22)
- 2 Speedometer
- 3 Operation of stopwatch^{OE} (➡ 44)
Setting clock (➡ 40)
- 4 Multifunction display (➡ 22)
- 5 Selecting readings (➡ 40)
Resetting tripmeter (➡ 41)
- 6 Anti-theft alarm indicator light (OE), Sensor for instrument lighting, Engine speed warning indicator
- 7 Tachometer

▶ The instrument-cluster lighting has automatic day and night switchover.◀

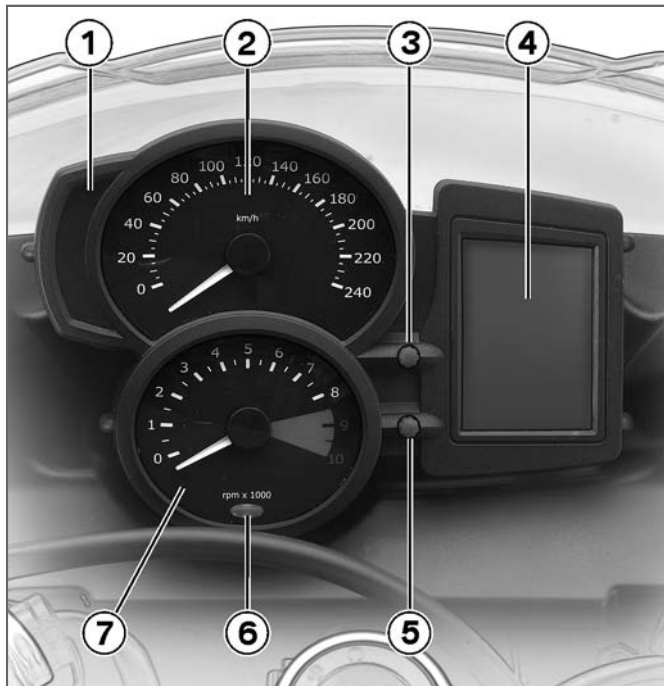

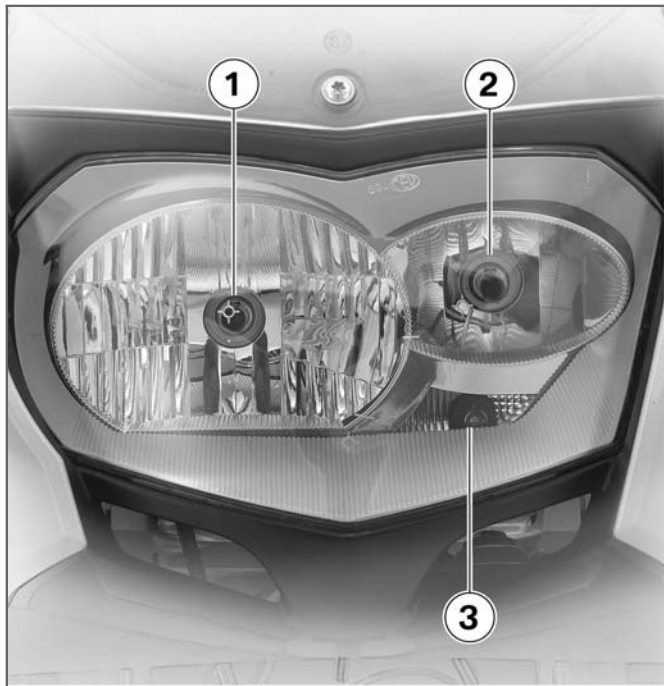

Headlight

- 1 Low-beam headlight
- 2 High-beam headlight
- 3 Parking lights

Status indicators

Standard displays	22
Displays with onboard computer ^{OE}	23
Displays with Tire Pressure Control TPC ^{OE}	24
Standard warning indicators	24
Warning indicators of onboard computer (OE)	29
ABS displays ^{OE}	29
TPC displays ^{OE}	32
Anti-theft alarm warning indicators (OE)	35

Standard displays

Multifunction display

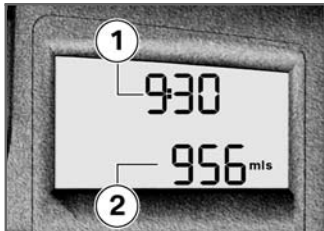

- 1 Clock (→ 40)
- 2 Odometer and tripmeters (→ 40)

Indicator lights

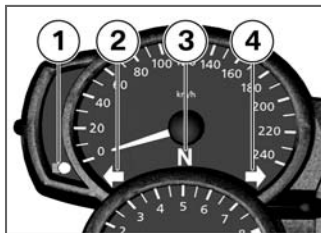

- 1 High-beam headlight
- 2 Flashing turn indicators, left
- 3 Idling
- 4 Flashing turn indicators, right

Service display

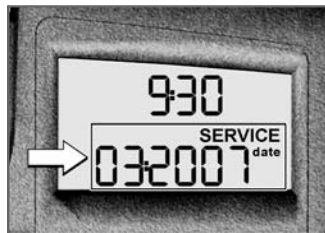

If the time remaining until the next service lies within a month, the service date is briefly displayed following the pre-ride check. The month and year are shown with two and four digits respectively separated by a colon. In this example the display means "March 2007".



If the motorcycle is driven long distances annually, it is possible that earlier service is required. If the odometer reading for the earlier service lies within 600 miles (1,000 km), the remaining miles (kilometers) are counted down in 60-mile (100-km) steps and briefly displayed following the pre-ride check.

If the service interval has been exceeded, the general warning light also lights up yellow in addition to the date or mileage display. The Service lettering is displayed continuously.

▶ If the service display already more than one month before the service date, or if the Service lettering does not stop after the service date is exceeded, then the date stored in the instrument cluster must be set. This situation can occur if the battery has been disconnected for a longer time. Consult a certified workshop, preferably an authorized BMW Motorrad retailer, for setting of the date.◀

Displays with onboard computer^{OE}

Multifunction display

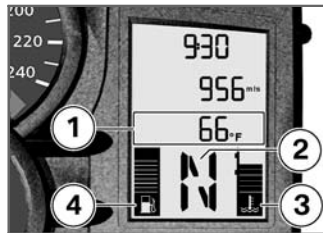

- 1 Onboard computer display area^{OE} (➡ 41)
- 2 Gear indicator (➡ 23)
- 3 Coolant temperature (➡ 24)
- 4 Fuel capacity (➡ 24)

Gear indicator

N The gear engaged or N for neutral appears on the display.

N If no gear is engaged, the 'neutral' indicator light also lights up.

Coolant temperature

 The horizontal bars over the temperature symbol show the coolant temperature level.

Fuel capacity

 The horizontal bars over the filling station symbol indicate the remaining fuel quantity. The top cross bar is shown enlarged and is equal to a correspondingly higher fuel level than the other cross bars.

When the fuel in the tank is topped up the gauge briefly shows the original level, before the reading is updated.

Displays with Tire Pressure Control TPC^{OE}

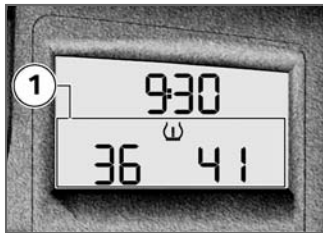

1 Tire pressures in alternation with odometers^{OE} (→ 46)

Standard warning indicators

Display

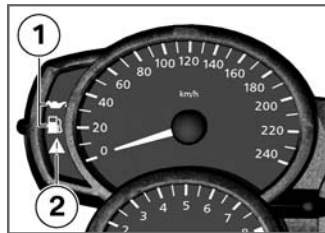

Warnings are indicated by the warning lights **1** or by the general warning light **2** in conjunction with a warning or a warning symbol in the multifunction display. The general warning light lights up red or yellow, depending on the urgency of the warnings.

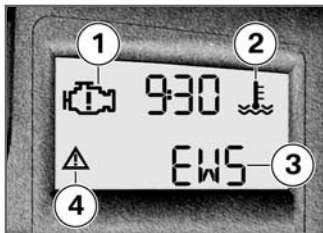











The possible warnings are listed on the next page.

The warning symbols **1** and **2** can be shown in the multifunction display. Warnings like **3** are shown in the display area of the odometer preceded by the warning triangle **4**.

If several warnings are active, all corresponding warning lights and symbols are displayed. Warnings can be displayed in alternation with the odometers (40). The general warning light is shown in accordance with the most urgent warning.

Overview of warning indicators

		Meaning		
	Lights up yellow		Is indicated	Electronic immobilizer is active (→ 27)
		EWS appears on the display		
	Lights up			Fuel down to reserve (→ 27)
	Lights up red		Temperature symbol flashes	Coolant temperature too high (→ 27)
	Lights up yellow		Is indicated	Engine in emergency-operation mode (→ 27)
	Flashes			Engine oil pressure insufficient (→ 28)
	Lights up yellow		Is indicated	Bulb defective (→ 28)
		LAMP appears on the display		

Electronic immobilizer is active

 General warning light shows yellow.

 Warning triangle appears on the display.

EWS appears on the display. The key being used is not authorized for starting, or communication between the key and engine electronics is disrupted.

- Remove other motorcycle keys from the ignition key ring.
- Use the reserve key.
- Have the defective key replaced, preferably by an authorized BMW Motorrad retailer.

Fuel down to reserve

 Fuel-reserve warning light lights up.

 A fuel shortage can lead to misfiring and to the engine dying unexpectedly. Misfiring can damage the catalytic converter,

and the engine dying unexpected can lead to accidents.

Do not drive until the fuel tank is completely empty. ◀

At the most, the fuel tank still contains the reserve fuel quantity.

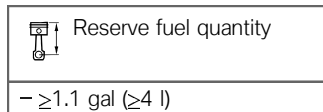

- Refueling (➡ 68)

Coolant temperature too high

 General warning light shows red.

 The temperature symbol flashes.

 Continued driving with an overheated engine can result in engine damage. Be sure to observe the measures listed below. ◀

Coolant level is too low.

- Checking coolant level (➡ 93)
- If coolant level is too low:
- Topping up coolant (➡ 93)

The coolant temperature is too high.

- If possible, continue driving in the part-load range to cool down the engine.
- In traffic jams, switch off the engine, but keep the ignition switched on so that the radiator fan continues to operate.
- Should the coolant temperature frequently be too high, have the fault rectified as quickly as possible by a specialized workshop, preferably an authorized BMW Motorrad retailer.

Engine in emergency-operation mode

 General warning light shows yellow.



Engine symbol appears on the display.



The engine is in the emergency operating mode. Only reduced engine performance may be available, which can lead to danger driving situations, especially during passing maneuvers.

Adapt your driving style to the possibly reduced engine performance. ◀

The engine control unit has diagnosed a fault. In exceptional cases, the engine stops and can no longer be started. Otherwise, the engine runs in the emergency operating mode.

- Continued driving is possible, however the accustomed engine performance may not be available.
- Have the malfunction corrected as soon as possible by a specialized workshop, preferably

an authorized BMW Motorrad retailer.

Engine oil pressure insufficient



Engine oil-pressure warning light flashes.

The oil pressure in the lubricating oil circuit is too low. If the warning light lights up, stop immediately and switch off the engine.



The warning on insufficient engine oil pressure is no substitute for the function of an oil-level indicator. The correct engine oil level can only be checked on the oil dipstick. ◀

The cause of the warning on insufficient engine oil pressure can be an insufficient engine oil level.

- Checking engine oil level (➡ 87)
- If oil level is too low:
- Topping up engine oil (➡ 88)

If the engine oil level is correct:



Driving with insufficient engine oil pressure can result in engine damage.

Do not continue driving. ◀

- Have the malfunction corrected as soon as possible by a specialized workshop, preferably an authorized BMW Motorrad retailer.

Bulb defective



General warning light shows yellow.



Warning triangle appears on the display.

LAMP appears on the display.



A defective bulb places your safety at risk because it is easier for other users to oversee the motorcycle.

Replace defective bulbs as soon as possible; always carry a

complete set of spare bulbs if possible. ◀

Low-beam headlight, parking light, tail light, brake light or turn indicator bulb defective.

- Locate defective bulb with visual check.
- Replacing high-beam/low-beam bulb (➡ 104)
- Replacing parking light bulb (➡ 106)
- Replacing brake light and tail light bulbs (➡ 108)
- Replacing front or rear turn indicator bulbs (➡ 109)

Warning indicators of onboard computer (OE)



The ambient temperature display flashes.

The ambient temperature measured at the motorcycle is lower than 37 °F (3 °C).



The ice warning does not mean that there is no risk of black ice forming at measured temperatures above 37 °F (3 °C). Always think well ahead when temperatures are low, especially on bridges and where the road is in the shade. ◀

- Think well ahead when driving.

ABS displays^{OE} Display

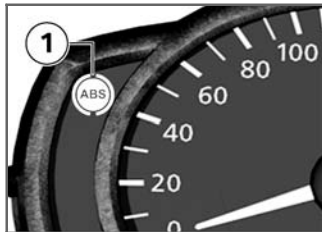

ABS warnings are indicated by the ABS warning light **1**. In some countries an alternative display of the ABS warning light is possible.



Possible country-dependent versions.

Additional information on the BMW Motorrad ABS is provided from page (➡ 72); an overview

of the possible warnings is provided on the following page.

Overview of warning indicators

Meaning

 Flashes	Self-diagnosis not completed ( 32)
 Lights up	ABS error ( 32)

Self-diagnosis not completed



ABS warning light flashes.

The ABS function is not available, because the self-diagnosis has not been completed. To check the wheel sensors, the motorcycle must be driven a few yards.

- Ride off slowly. It must be noted that the ABS function is not available until the self-diagnosis has been completed.

ABS error



ABS warning light lights up.

The ABS control unit has detected an error. The ABS function is not available.

- Continued driving is possible. It must be noted that the ABS function is not available. Observe additional information on

situations which can lead to an ABS error (➔ 73).

- Have the malfunction corrected as soon as possible by a specialized workshop, preferably an authorized BMW Motorrad retailer.

TPC displays^{OE}

Display

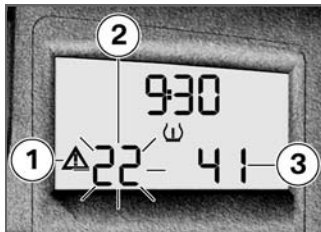

The warning symbol **1** signals a critical tire pressure, and the corresponding air pressure of the front wheel **2** or the rear wheel **3** flashes.











If the critical value is at the limit of the permissible tolerance, the general warning light also lights up in yellow. If the determined tire pressure is outside the permissible tolerance, the general warning light flashes in red.

Additional information on the BMW Motorrad TPC is provided from page (➔ 74); an overview of the possible warnings is provided on the following page.

Overview of warning indicators

Meaning

 Lights up yellow	 Is indicated	Tire pressure in limit area of permissible tolerance (→ 34)
	The critical air pressure flashes	
 Flashes red	 Is indicated	Tire pressure outside permissible tolerance (→ 34)
	The critical air pressure flashes	
	"--" or "-- --" is displayed	Transmission error (→ 34)
 Lights up yellow	 Is indicated	Sensor defective or system fault (→ 35)
	"--" or "-- --" is displayed	
 Lights up yellow	 Is indicated	Battery of tire pressure sensor weak (→ 35)
	RdC appears on the display.	

Tire pressure in limit area of permissible tolerance

 General warning light shows yellow.

 Warning triangle appears on the display.

The critical air pressure flashes. The measured tire pressure is in the limit area of the permissible tolerance.

- Correct tire pressure in accordance with instructions on back of cover of Rider's Manual.

 The pressure values on the back of the cover refer to a tire air temperature of 68 °F (20 °C). To also adapt the air pressure at other tire temperatures, proceed as follows:

Calculate the difference between the nominal value according to the Rider's Manual and the value determined by the TPC system. Change the air pressure in the tire by this difference using

an air pressure tester at a filling station. ◀

Tire pressure outside permissible tolerance

 General warning light flashes red.

 Warning triangle appears on the display.

The critical air pressure flashes. The measured tire pressure is outside the permissible tolerance.

- Check tire for damage and drivability.
- Is it still possible to drive with tire:
-  Incorrect tire pressure result in poorer handling of the motorcycle.

Always adapt your driving style to the incorrect tire pressure. ◀

- Correct tire pressure at next opportunity.
- Have the tire checked for damage by a specialized workshop,

preferably an authorized BMW Motorrad retailer.

If you are unsure about the drivability of the tire:

- Do not continue driving.
- Inform roadside service.
- Have the tire checked for damage by a specialized workshop, preferably an authorized BMW Motorrad retailer.

Transmission error

"--" or "-- --" is displayed.

The motorcycle's speed has not exceeded the threshold of approx. 20 mph (30 km/h). The TPC sensors do not transmit their signal until a speed above this threshold is reached (➡ 74).

- Watch TPC display at higher speed. A permanent fault has not occurred until the general warning light also lights up. In this case:
- Have fault eliminated by a specialized workshop, preferably

an authorized BMW Motorrad retailer.

There is a fault in the radio connection to the TPC sensors.

Possible causes are radio systems in the surrounding area, which interfere with the connection between the TPC control unit and the sensors.

- Watch the TPC display in another environment. A permanent fault has not occurred until the general warning light also lights up. In this case:
- Have fault eliminated by a specialized workshop, preferably an authorized BMW Motorrad retailer.

Sensor defective or system fault



General warning light shows yellow.



Warning triangle appears on the display.

"_ _" or "_ _ _ _" is displayed.

Wheels without installed TPC sensors are mounted.

- Retrofit wheel set with TPC sensors.

One or two TPC sensors have failed.

- Have fault eliminated by a specialized workshop, preferably an authorized BMW Motorrad retailer.

A system fault has occurred.

- Have fault eliminated by a specialized workshop, preferably an authorized BMW Motorrad retailer.

Battery of tire pressure sensor weak



General warning light shows yellow.



Warning triangle appears on the display.

RdC appears on the display.



This error message is only displayed for a short time following the pre-ride check. ◀

The battery of the tire pressure sensor no longer has its full capacity. The operation of the tire pressure control is only ensured for a limited time.

- Contact a specialized workshop, preferably an authorized BMW Motorrad retailer.

Anti-theft alarm warning indicators (OE)



General warning light shows yellow.



The warning dWA is displayed with the warning triangle in front of it.

▶ This error message is only displayed for a short time following the pre-ride check.◀

The anti-theft alarm battery has no capacity. The operation of the anti-theft alarm is no longer ensured with the motorcycle battery disconnected.

- Contact a specialized workshop, preferably an authorized BMW Motorrad retailer.

Operation

Ignition switch and steering lock	38	Damping	53
Electronic immobilizer	39	Tires	54
Clock	40	Headlight	55
Odometer and tripmeters	40	Seat	56
Onboard computer ^{OE}	41	Helmet holder	56
Tire Pressure Control TPC ^{OE}	46		
Lights	46		
Turn indicators	47		
Hazard warning flashers	48		
Emergency ON/OFF switch	50		
Heated hand grips ^{OE}	50		
Clutch	51		
Brakes	51		
Mirrors	52		
Spring preload	52		

Ignition switch and steering lock

Keys

You receive one master key and one spare key. If a key is lost, please note the information on the electronic immobilizer (EWS) (➡ 39).

Ignition key and steering lock, tank filler cap lock and seat lock are all operated with the same key.

with OA Case and with OA Topcase:

The cases and the Topcase can also be ordered with locks for the same key on request. Please contact a specialized workshop for this purpose, preferably an authorized BMW Motorrad retailer.<

Switching on ignition



- Turn key to position **1**.
 - » Parking lights and all function circuits switched on.
 - » Engine can be started.
 - » Pre-ride check is performed. (➡ 63)

with OE BMW Motorrad ABS:

- Turn key to position **1**.
 - » In addition to the points named above, the ABS self-diagnosis is also carried out. (➡ 64)<

Switching off ignition

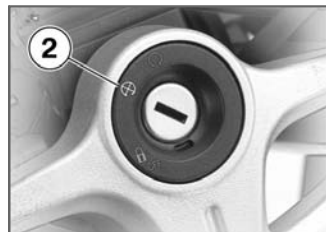

- Turn key to position **2**.
 - » Light switched off.
 - » Handlebars not locked.
 - » Key can be removed.
 - » Electrically powered accessories remain operational for a limited period of time.
 - » Battery can be recharged via onboard socket.

Locking handlebars

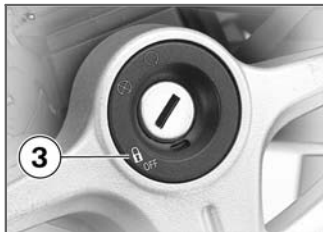

- Turn handlebars to left.
- Turn key to position **3** while moving handlebars slightly.
- » Ignition, lights and all function circuits switched off.
- » Handlebars locked.
- » Key can be removed.

Electronic immobilizer

Theft protection

The electronic immobilizer helps protect your BMW motorcycle from theft, and this enhanced security is at your disposal without any need for you to set pa-

rameters or activate additional systems. The engine of a motorcycle fitted with this electronic immobilizer can be started only with the keys that belong to the motorcycle. You can also have your authorized BMW Motorrad retailer disable particular keys, for example in the event that you lose your keys. The engine cannot be started with a key that has been barred.

Electronics in key

The motorcycle's electronics exchange certain continuously changing signals with the electronics in the key; these signals are specific to your motorcycle and they are transmitted via the ring antenna in the ignition lock. The ignition is not enabled for starting until the key has been recognized as "authorized" for your motorcycle.

▶ A spare key attached to the same ring as the ignition key used to start the engine could "irritate" the electronics, in which case the enabling signal for starting is not issued. The warning EWS is shown in the multifunction display. Always store the spare key separately from the ignition key. ◀

Replacement and extra keys

Replacement and spare keys are only available through an authorized BMW Motorrad retailer. The keys are part of an integrated security system, so the retailer is under an obligation to check the legitimacy of all applications for replacement/extra keys. If you want to have a lost key barred, you must bring along all other keys that belong to the motorcycle. A key that has been barred

can subsequently be cleared and reactivated for use.

Clock

Setting clock

 Attempting to set the clock while riding the motorcycle can lead to accidents. Adjust the clock only when the motorcycle is stationary. ◀

- Switch on ignition.

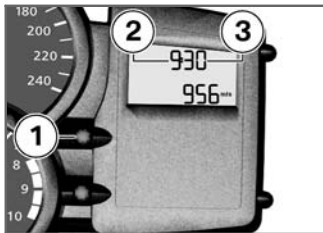

- Hold down button **1**.
- » Hours **2** flash.
- Press button **1**.

» Hours increase by one each time button is pressed.

- Hold down button **1**.
- » Minutes **3** flash.
- Press button **1**.
- » Minutes increase by one each time button is pressed.
- Press and hold button **1** or do not press any further button.
- » End setting; set time is displayed.

Odometer and tripmeters

Selecting readings

- Switch on ignition.

with OE Onboard computer:

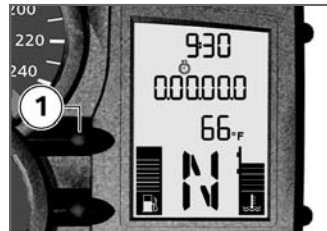

- If necessary, switch over from stopwatch to odometer with button **1**. ◀



- Press button **2**.

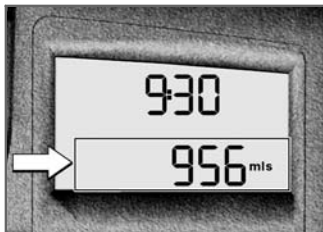

Each time the button is pressed, the display shows values starting with the current value in the following order:

- Total distance covered
- Tripmeter 1 (Trip I)
- Tripmeter 2 (Trip II)
- Tire pressures (OE)
- Warnings if necessary

Resetting tripmeter

- Switch on ignition.
- Select desired tripmeter.

- Press and hold button **2**.
- » Tripmeter is reset.

Onboard computer^{OE}

Selecting readings

- Switch on ignition.

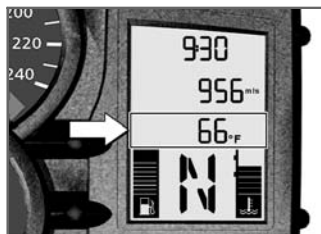

Each time the button is pressed, the display shows values starting with the current value in the following order:

- Ambient temperature

- Average speed
- Average consumption
- Range

Ambient temperature

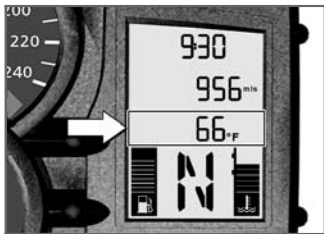

When the motorcycle is stopped, the engine heat can falsify the measurement of the ambient temperature. If the influence of the engine heat becomes too great, -- is temporarily shown in the display.

If the ambient temperature drops below 3 °C, the temperature display flashes as a warning of possible icing-up. The display auto-

matically switches from any other mode to the temperature reading when the temperature drops below this threshold for the first time.

Average speed

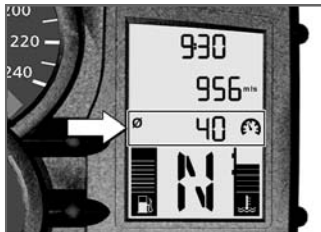

The average speed is calculated based on the elapsed time since the last reset. Times during which the engine was stopped are excluded from the calculation.

Resetting average speed

- Switch on ignition.
- Select average speed.



- Hold down button 1.
- » Average speed is reset.

Average consumption

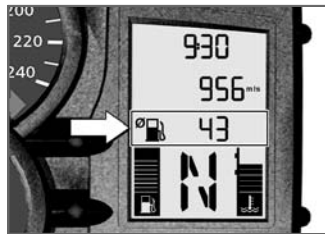

The average consumption is calculated by dividing the distance covered since the last reset by

the corresponding amount of fuel used.

Resetting average consumption

- Switch on ignition.
- Select average consumption.



- Hold down button **1**.
- » Average consumption is reset.

Range



The range indicates what distance can still be driven with the remaining fuel. The calculation is made based on the fuel level and an average consumption stored for this purpose, however which need not always match the value that can be called up in the display.

With a completely filled fuel tank, the fuel volume cannot be determined exactly. In this area a minimum range is indicated, marked with a > symbol. As soon as the fuel level can be determined ex-

actly, the range is shown more precisely.

If the motorcycle is standing on the side stand, the fuel level cannot be correctly determined due to the inclined position. For this reason the range is only calculated while driving.

When refueling after running on reserve, make sure that you top up the tank to a level above reserve, as otherwise the sensor will not be able to register the new level. Otherwise neither the fill level nor the range display can be updated.

 The determined range is an approximate reading. BMW Motorrad therefore recommends that you do not try to use the full range before refueling.◀

Stopwatch

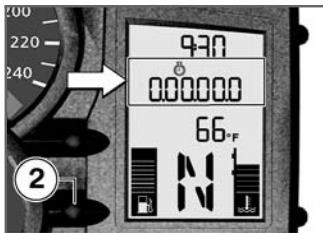

As an alternative to the odometer, the stopwatch can be displayed. The display consists of hours, minutes, seconds and tenths of a second separated by dots.

To use the stopwatch as a lap timer, it can also be operated via the INFO button on the handlebar fitting instead of with the button **2**. If the operation of the stopwatch is set to the INFO button, the onboard computer must be operated with the button **2**.

The stopwatch continues to run in the background when the display is temporarily switched over to the odometer. The stopwatch also continues to run when the ignition is temporarily switched off.

Operating stopwatch



- If necessary, switch over from odometer to stopwatch with button **1**.



- Press stopped stopwatch button **2**.
- » Stopwatch runs starting from indicated time in steps of one-tenth of a second.
- Press button **2** with stopwatch running.
- » Stopwatch shows the time measured.
- Press and hold button **2**.
- » Stopwatch is reset and shows 0.00.00.0.

Using stopwatch as Lap-Timer

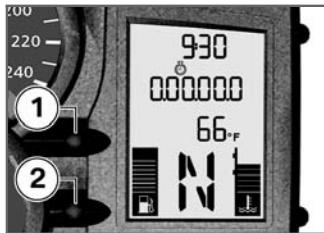

- Press and hold button **1** and button **2** simultaneously until display changes.
- » **FLASH** (display of engine speed warning) and **ON** or **OFF** are shown.
- Press button **2**.
- » **LAP** (Lap-Timer) and **ON** or **OFF** are shown.
- Press button **1** repeatedly until desired state is shown.
- » **ON**: Operation of stopwatch with **INFO** button on handlebar fitting.

- » **OFF**: operation of stopwatch with button **2** in instrument cluster.
- To confirm setting, press and hold button **1** and button **2** simultaneously until display changes.
- » The settings are applied and the last display is shown.
- » If no confirmation is made, the last setting is retained.

Engine speed warning



The engine speed warning signals to the driver that the red engine speed range has been reached. This signal is shown in

red by the flashing of the anti-theft alarm indicator light **1**. The signal is maintained until the transmission is upshifted or the engine speed is reduced. It can be activated or deactivated by the driver.

Activating engine speed warning

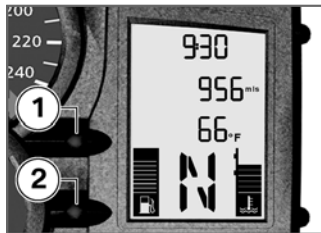

- Press and hold button **1** and button **2** simultaneously until display changes.
- » **FLASH** (display of indicator light) and **ON** or **OFF** are shown.

- Press button **1** until desired state is shown.
- » **ON**: engine speed warning activated.
- » **OFF**: engine speed warning deactivated.
- To confirm setting, press and hold button **1** and button **2** simultaneously until display changes.
- » The settings are applied and the last display is shown.
- » If no confirmation is made, the last setting is retained.

Tire Pressure Control TPC^{OE}

Selecting TPC display

- Switch on ignition.



- Press button **2** repeatedly until tire pressures are shown.

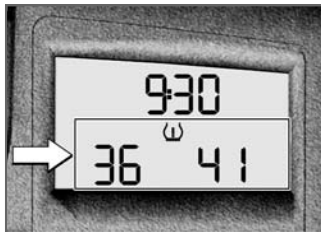

The tire pressures are shown alternately with the mileage display. The left-hand value indicates the air pressure of the front wheel, and the right-hand val-

ue the air pressure of the rear wheel. Immediately after switching on the ignition, -- -- is displayed, as the transfer of the air pressure values does not begin until a speed over 20 mph (30 km/h) is reached.

 Indicates the display of the tire pressure.

Lights

Parking lights

The parking lights switch on automatically when the ignition is switched on.

 The parking lights are a strain on the battery. Do not leave the ignition switched on longer than absolutely necessary. ◀

Low-beam headlight

The low-beam headlight switches on automatically when you start the engine.

▶ With the engine switched off, you can switch on the lights by switching on the high-beam headlight with the ignition switched on or by operating the headlight flasher.◀

High-beam headlight



- Press the top section of full-beam headlight switch **1**.
- » High-beam headlight is switched on.

- Move full-beam headlight switch **1** to the center position.
- » High-beam headlight is switched off.
- Press the bottom section of full-beam headlight switch **1**.
- » High-beam headlight is switched on as long as switch is pressed (headlight flasher).

Switching on parking lights

- Switch off ignition.



- Immediately after switching off the ignition, press and hold the

left-hand turn indicator button **1**.

- » Parking light switches on.

Switching off parking lights

- Switch ignition on and then off again.
- » Parking light switched off.

Turn indicators

Switching on left-hand turn indicator

- Switch on ignition.

▶ After driving for approx. ten seconds or after covering a distance of approx. 650 ft (200 m), the turn indicators are automatically switched off.◀



- Press left-hand turn indicator button **1**.
- » Left-hand turn indicator is switched on.
- » Indicator light for left-hand turn indicators flashes.

Switching on right-hand turn indicator

- Switch on ignition.

▶ After driving for approx. ten seconds or after covering a distance of approx. 650 ft (200 m), the turn indicators are automatically switched off. ◀



- Press right-hand turn indicator button **2**.
- » Right-hand turn indicator is switched on.
- » Indicator light for right-hand turn indicators flashes.

Switching off turn indicator



- Press turn-indicator cancel button **3**.
- » Turn indicator is switched off.
- » Indicator lights for turn indicators are off.

Hazard warning flashers

Switching on hazard warning flashers

- Switch on ignition.

▶ The hazard warning flashers place a strain on the battery. Do not use the hazard warning flashers for longer than absolutely necessary.◀

▶ If a turn indicator button is pressed with the ignition switched on, the flashing function replaces the emergency flashing function as long as the button is pressed. If the turn indicator button is released, the emergency flasher function becomes active again.◀

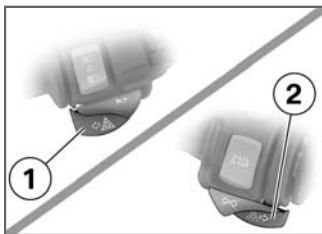

- Press left **1** and right-hand **2** turn indicator buttons simultaneously.
 - » The hazard warning flashers are switched on.
 - » Left/right turn indicator lights flash.
- Switch off ignition.
 - » Hazard warning flashers continue to operate.
 - » Indicator lights of left and right turn indicator are off.

Switching off hazard warning flashers



- Press turn-indicator cancel button **3**.
 - » Hazard warning flashers are switched off.

Emergency ON/OFF switch



1 Emergency ON/OFF switch

! Operating the emergency ON/OFF switch when riding can cause the rear wheel to lock and thus cause a fall.

Do not operate the emergency ON/OFF switch when riding.◀

The engine can be switched off easily and quickly using the emergency ON/OFF switch.

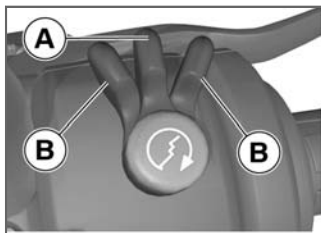

- A** Operating position
B Engine switched off.

▶ The engine can only be started in the operating position.◀

Heated hand grips^{OE}



1 Heated hand grip switch

The handlebar grips can be heated at two different levels. The heated hand grips option can only be activated when the engine is running.

▶ The increase in power consumption caused by the heated hand grips can drain the battery if you are riding at low engine speeds. If the battery is inadequately charged, the heated hand grips are switched off to ensure starting capability.◀

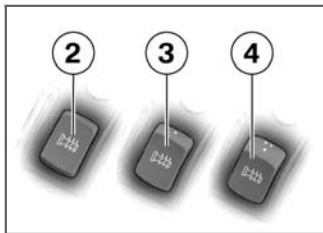

- 2 Heating function off.
- 3 50 % heat output (one dot visible).
- 4 100 % heat output (three dots visible).

Clutch

Adjusting clutch lever

! If the position of the clutch fluid reservoir is changed, air can enter the clutch system. Do not reposition the handlebar controls on the handlebars or the handlebars in their mounts.◀

! Adjusting the clutch lever while driving can lead to accidents. Only adjust the clutch lever when the motorcycle is stationary.◀

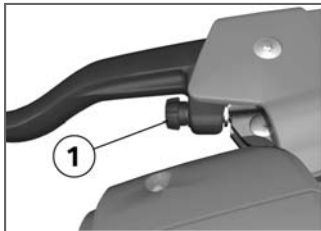

- Turn adjusting screw **1** clockwise.
- ▶ The adjusting screw has a limit position and can be turned more easily when you press the clutch lever forward.◀
- » Distance between handlebar grip and clutch lever increases.
- Turn adjusting screw **1** counterclockwise.

» Distance between handlebar grip and clutch lever decreases.

Brakes

Adjusting handbrake lever

! Changing the position of the brake-fluid reservoir can allow air to penetrate the brake system.

Do not reposition the handlebar controls on the handlebars or the handlebars in their mounts.◀

! Adjusting the brake lever while driving can lead to accidents.

Only adjust the brake lever when the motorcycle is stationary.◀

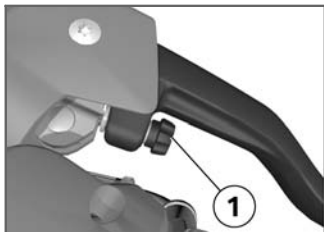

- Turn adjusting screw **1** clockwise.

▶ The adjusting screw has a limit position and can be turned more easily when you press the handbrake lever forward.◀

- » Distance between handlebar grip and handbrake lever increases.
- Turn adjusting screw **1** counterclockwise.
- » Distance between handlebar grip and handbrake lever decreases.

Mirrors

Adjusting mirrors

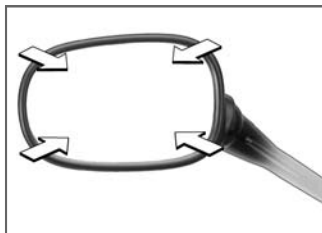

- Move mirror into desired position by twisting.

Spring preload

Spring preload

It is essential to set spring preload of the rear suspension to suit the load carried by the motorcycle. Increase spring preload when the motorcycle is heavily loaded and reduce spring preload accordingly when the motorcycle is lightly loaded.

Adjusting spring preload for rear wheel

- Removing seat (→ 56)



- Remove toolkit **1**.

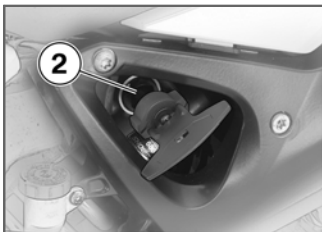

 Basic setting of spring preload, rear

– Turn adjusting screw counterclockwise as far as possible and then turn back 12 clicks (Full tank of gas, with rider 187 lbs (85 kg))

with OE Lowered suspension:

– Turn adjusting screw counterclockwise as far as possible and then turn back 4 clicks (Full tank of gas, with rider 187 lbs (85 kg))<



• Insert toolkit **1**.

• Installing seat (➡ 56)

Damping

Damping

The damping must be adapted to the spring preload. An increase in spring preload requires firmer damping, a reduction in spring preload requires softer damping.

Adjusting damping on rear wheel

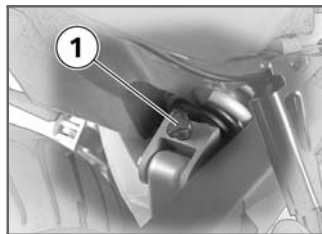

• Adjust damping via adjusting screw **1**.

 Your motorcycle's handling will suffer if you do not match the spring-preload and damping-characteristic settings. Adjust the damping characteristic to suit the spring preload.◀

- To increase spring preload, turn handwheel **2** clockwise using toolkit.
- To decrease spring preload, turn handwheel **2** counterclockwise using toolkit.

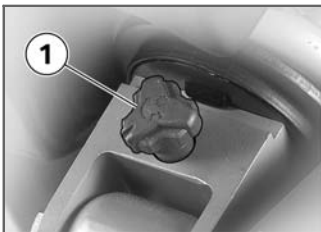

- To increase damping, turn adjusting screw **1** clockwise.
- To decrease damping, turn adjusting screw **1** counterclockwise.

 Basic setting of rear wheel rear-wheel damping

- Turn adjusting screw clockwise as far as possible and then turn back 1 1/2 clicks (Full tank of gas, with rider 187 lbs (85 kg))

Tires

Checking tire pressure

- Make sure ground is level and firm and park motorcycle.

 Incorrect tire inflation pressure results in poorer handling characteristics of the motorcycle and reduces the life of the tires.

Ensure proper tire inflation pressure. ◀

 At high road speeds, tire valves have a tendency to open as a result of centrifugal force.

Fit metal valve caps with rubber seals and screw them on firmly to prevent sudden deflation. ◀

- Check tire pressures against data below.



Tire pressure, front

- 36.3 psi (2.5 bar) (Single rider, with cold tire)
- 36.3 psi (2.5 bar) (Driver with passenger and/or load, with cold tire)



Tire pressure, rear

- 40.6 psi (2.8 bar) (Single rider, with cold tire)
- 40.6 psi (2.8 bar) (Driver with passenger and/or load, with cold tire)

If tire pressure is too low:

- Correct tire pressure.

Headlight

Adjusting headlight for RHD/LHD traffic

If the motorcycle is ridden in a country where the opposite rule of the road applies, its asymmetric low-beam headlight will tend to dazzle oncoming traffic.

Have the headlight adjusted to the relevant conditions by a specialized workshop, preferably an authorized BMW Motorrad retailer.



Ordinary adhesive tape damages the plastic lens.

To prevent damage to the plastic lens, consult a specialized workshop, preferably an authorized BMW Motorrad retailer. ◀

Headlight range and spring preload

The headlight range generally remains constant due to the adjustment of the spring preload to the loading state.

Spring preload adjustment may only be insufficient when the motorcycle is very heavily loaded. In this case, the headlight range must be adjusted to the weight.

▶ If you are unsure whether the basic headlight setting is correct, consult a specialized workshop, preferably an authorized BMW Motorrad retailer. ◀

Adjusting headlight range

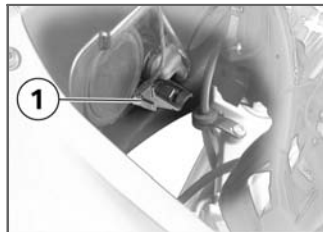

1 Headlight range adjustment

In the case of very high payloads, the available spring preload adjustment might not be adequate. To avoid dazzling oncoming traffic, the headlight adjustment can be corrected by adjusting the swivel lever.

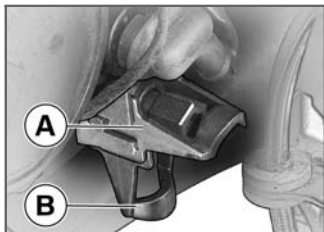

- A** Neutral position
B Position with heavy payload

Seat

Removing seat

- Make sure ground is level and firm and park motorcycle.

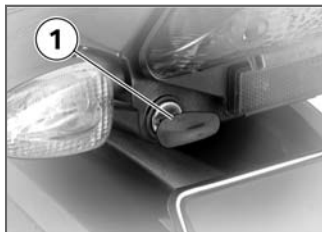

- Unlock seat lock **1** with ignition key and hold.

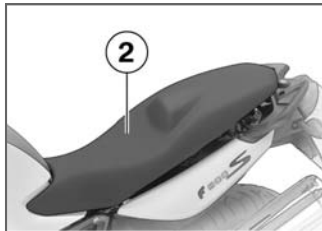

- Remove seat **2**.
- Place seat on a clean surface with seat surface facing downward.

Installing seat



- Push seat **2** forward into retaining brackets **3**.
 - Firmly press down on seat at rear.
- » Seat can be heard to lock into place.

Helmet holder

Locking helmet on motorcycle

- Removing seat (🔗 56)

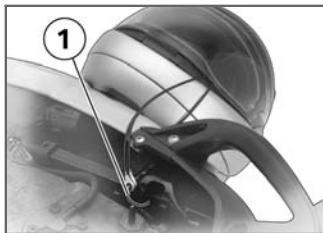

watch the position of the helmet lock.◀

- To do this, guide steel cable through helmet and push cable eyes onto holder **1**.
- Installing seat (➡ 56)

- Secure helmet on helmet holder **1** using steel cable available as an optional accessory.



 The helmet catch can scratch the paneling.
When hooking on the helmet,

Riding

Safety instructions	60
Checklist	61
Starting	62
Running in	64
Brakes	65
Parking your motorcycle	66
Refueling	68

Safety instructions

Rider's equipment

Do not ride without the correct clothing. Always wear:

- Helmet
- Rider's suit
- Gloves
- Boots

This applies even to short journeys, and to every season of the year. Your authorized BMW Motorrad retailer will be happy to advise you and has the correct clothing for every purpose.

Speed

If you ride at high speed, always bear in mind that various boundary conditions can adversely affect the handling of your motorcycle:

- Settings of spring-strut and shock absorber system
- Imbalanced load

- Loose clothing
- Insufficient tire inflation pressure
- Poor tire tread
- Etc.

Correct loading



Overloading and imbalanced loads can adversely affect the motorcycle's handling. Do not exceed the gross weight limit and observe the loading information.◀

Alcohol and drugs



Even small amounts of alcohol or drugs will adversely affect your perception and your ability to assess situations and make decisions, and slow down your reflexes. Medication can exacerbate these effects.

Do not ride your motorcycle after consuming alcohol, drugs and/or medication.◀

Risk of poisoning

Exhaust fumes contain carbon monoxide, which is colorless and odorless but highly toxic.



Inhaling exhaust fumes therefore represents a health hazard and can even cause loss of consciousness with fatal consequences.

Do not inhale exhaust fumes. Do not run the engine in closed rooms.◀

High voltage



Touching live parts of the ignition system with the engine running can cause electric shock.

Do not touch parts of the ignition system when the engine is running.◀

Catalytic converter

If misfiring causes unburned fuel to enter the catalytic converter, there is a danger of overheating and damage.

For this reason, observe the following points:

- Do not run the fuel tank dry
- Do not run the engine with the spark-plug cap removed
- Stop the engine immediately if it misfires
- Use unleaded fuel only
- Comply with all specified maintenance intervals.

 Unburned fuel will destroy the catalytic converter. Note the points listed for protection of the catalytic converter. ◀

Risk of fire

Temperatures at the exhaust are high.

 Flammable materials (e.g. hay, leaves, grass, clothing and luggage, etc.) could ignite if allowed to come into contact with the hot exhaust pipe. Make sure that no highly flammable materials can come in contact with the hot exhaust system. ◀

 Cooling would be inadequate if the engine were allowed to idle for a lengthy period with the motorcycle at a standstill: overheating would result. In extreme cases, the motorcycle could catch fire. Do not allow the engine to idle unnecessarily. After starting, ride off immediately. ◀

Tampering with control unit of electronic engine-management system

 Tampering with the engine control unit can damage the motorcycle and cause accidents.

Do not tamper with the engine control unit. ◀

 Tampering with the engine control unit can result in mechanical loads that the motorcycle's components are not designed to withstand. Damage caused in this way is not covered by the warranty. Do not tamper with the engine control unit. ◀

Checklist

Use the following checklist to check important functions, settings and wear limits before you ride off.

- Brakes
- Front and rear brake fluid levels
- Clutch
- Shock absorber setting and spring preload
- Tread depth and tire inflation pressure
- Firm seating of cases and luggage

At regular intervals:

- Engine oil level (every time you refuel)
- Brake pad wear (during every third stop for refueling)

Starting

Side stand

You cannot start the motorcycle with the side stand extended and a gear engaged. The engine will switch itself off if you start it with the transmission in neutral and then engage a gear before retracting the side stand.

Transmission

You can start the engine when the transmission is in neutral or if you pull the clutch with a gear engaged. Do not engage the clutch until after switching on the ignition, as otherwise the engine cannot be started. When the transmission is in neutral, the green neutral indicator light is on and the gear indicator in the multifunction display shows **N**.

Starting engine

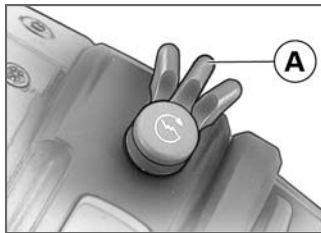

- Emergency ON/OFF switch in operating position **A**.



Transmission lubrication is only ensured when the engine is running. Insufficient lubrication can lead to transmission damage.

Do not allow the motorcycle to roll for longer periods or push it over longer distances with the engine switched off. ◀

- Switch on ignition.
 - » Pre-ride check is performed. (🔧 63)

with OE BMW Motorrad ABS:

- Switch on ignition.
 - » Pre-ride check is performed. (🔧 63)
 - » ABS self-diagnosis is performed. (🔧 64) ◀



- Press starter button **1**.

▶ At extremely low temperatures it may be necessary to operate the throttle twist grip during starting. At ambient temperatures below 32 °F (0 °C), actuate the clutch after switching on the ignition. ◀

▶ The start attempt is automatically interrupted if battery voltage is too low. Recharge the battery before you start the engine, or use jump leads and a donor battery to start. ◀

» Engine starts.

» If the engine fails to start, the troubleshooting table in the chapter "Technical Data" may provide assistance. (▶▶ 120)

Pre-ride check

After the ignition is switched on, the instrument cluster conducts a test of the pointer instruments and the warning and indicator lights. This so-called Pre-Ride-Check is canceled as soon as the engine is started.

Phase 1

The pointer of the tachometer and speedometer are run up to the end stop.

- » At the same time, the following warning and indicator lights are switched on consecutively:
- Indicator light for high-beam headlight and telltale light for left turn indicator
 - General warning light in yellow and indicator light for idling

- Warning light for fuel reserve and indicator light for right turn indicator
- Warning light for oil pressure

with OE BMW Motorrad ABS:

» ABS warning light

Phase 2

 General warning light changes from yellow to red.

Phase 3

The pointers of the tachometer and speedometer are run back. At the same time, all switched-on warning and indicator lights are switched off consecutively in the reverse order. If a pointer has not been moved, or if one of the specified warning and indicator lights has not been switched on:



If it was not possible to switch on the warning lights, possible malfunctions cannot be indicated.

Watch all warning and indicator lights on the display.◀

- Have the malfunction corrected as soon as possible by a specialized workshop, preferably an authorized BMW Motorrad retailer.

ABS self-diagnosis^{OE}

The readiness for operation of the BMW Motorrad ABS is checked by the self-diagnosis. Self-diagnosis is performed automatically when you switch on the ignition. To check the wheel sensors, the motorcycle must be driven a few yards.

Phase 1

- » Checking the diagnosable system components while stopped.



ABS warning light flashes.



Possible country-specific version of ABS warning light.

Phase 2

- » Checking the wheel sensors while starting off.



ABS warning light flashes.



Possible country-specific version of ABS warning light.

ABS self-diagnosis completed

- » The ABS warning light goes out.

If an ABS fault is indicated after the ABS self-diagnosis is completed:

- Continued driving is possible. It must be noted that the ABS function is not available.

- Have the malfunction corrected as soon as possible by a specialized workshop, preferably an authorized BMW Motorrad retailer.

Running in

The first 600 miles (1,000 km)

- While running in the motorcycle, vary the throttle opening and engine-speed range frequently.
- Try to do most of your riding during this initial period on twisting, fairly hilly roads, avoiding high-speed main roads and highways if possible.



Exceeding the specified engine speeds while running in will lead to increased engine wear.

Adhere to the specified engine run-in speeds.◀

- Do not exceed the engine run-in speeds.



Engine break-in speed

– <5000 min⁻¹

- Do not accelerate at full throttle.
- Avoid low engine speeds at full load.
- After 300 - 750 miles (500 - 1,200 km), have the first inspection performed.

Brake pads

New brake pads must "bed down" and therefore do not achieve their optimum friction levels during the first 300 miles (500 km). This initial reduction in braking efficiency can be compensated for by exerting greater pressure on the levers.



New brake pads can extend stopping distance by a significant margin.

Brake early. ◀

Tires

New tires have a smooth surface. This must be roughened by riding in a restrained manner at various heel angles until the tires are run in. This running in procedure is essential if the tires are to achieve maximum grip.



New tires have not achieved their full adhesion yet. There is a danger of accidents when driving at extreme angles.

Avoid extreme angles. ◀

Brakes

How is the shortest braking distance achieved?

The dynamic load distribution between the front and rear wheel changes during braking. The heavier you brake, the more the front wheel is loaded. The greater the wheel load, the more braking force can be transferred. To achieve the shortest possible braking distance, the front brake must be applied quickly and with increasing force. This optimally utilizes the dynamic load increase on the front wheel. At the same time, the clutch should also be actuated. With the "forced braking" often practiced in which the brake pressure is generated as quickly as possible and with great force, the dynamic load distribution cannot follow the increased deceleration and

the braking force cannot be completely transferred to the road surface. To prevent the front wheel from locking, the ABS system must intervene and reduce the brake pressure; the braking distance increases.

Descending mountain passes

 There is a danger of the brakes fading if you use only the rear brakes when descending mountain passes. Under extreme conditions, the brakes could overheat and suffer severe damage.

Use both front and rear brakes, and make use of the engine's braking effect as well. ◀

Wet brakes

 After washing the motorcycle, after driving through water or in the rain, braking can

be delayed due to damp brake disks and brake pads. Brake early until the brakes are dry or braked until dry. ◀

Salt on brakes

 The full braking effect can be delayed if the motorcycle is ridden on salt-covered roads and the brakes are not applied for some time.

Brake early until the salt layer of the brake disks and brake pads has been braked off. ◀

Oil or grease on brakes

 Oil and grease on the brake disks and pads considerably diminish braking efficiency.

Especially after repair and maintenance tasks, make sure that the brake disks and brake pads are free of oil and grease. ◀

Dirt or mud on brakes

 When the motorcycle is ridden on loose surfaces or muddy roads, the brakes may fail to take effect immediately because of dirt or moisture on the disks or brake pads.

Brake early until the brakes are braked clean. ◀

 Driving on unpaved or dirty roads leads to increased brake pad wear.

Check the brake pad thickness more often and replace the brake pads sooner. ◀

Parking your motorcycle

Placing on side stand

 If the ground is soft or uneven, there is no guarantee that the motorcycle will rest firmly on the stand.

Always check that the ground

under the stand is level and firm.◀

- Switch off the engine.
- Pull handbrake lever.
- Hold motorcycle upright and balanced.
- Use your left foot to extend side stand fully.

 The side stand is designed to support only the weight of the motorcycle.

Do not lean or sit on the motorcycle with the side stand extended.◀

- Slowly lean motorcycle to side until its weight is taken by stand and dismount to left.

 If the motorcycle is on the side stand, the surface of the ground will determine whether it is better to turn the handlebars to the left or right. However, the motorcycle is more stable on a level surface with the handlebars turned to the left than

with the handlebars turned to the right.

On level ground, always turn the handlebars to the left to set the steering lock.◀

- Turn handlebars to full left or right lock position.
- Check that motorcycle is standing firmly.

 On a grade, the motorcycle should always face uphill; select 1st gear.◀

- Lock steering lock.

Remove from side stand

- Unlock steering lock.
- From left, grip handlebars with both hands.
- Pull handbrake lever.
- Swing your right leg over seat and lift motorcycle to upright position.
- Hold motorcycle upright and balanced.



An extended side stand can catch on the ground when the motorcycle is moving and lead to a fall.

Retract the side stand before moving the vehicle.◀

- Sit on motorcycle and use your left foot to retract side stand.

Placing on center stand^{OA}



If the ground is soft or uneven, there is no guarantee that the motorcycle will rest firmly on the stand.

Always check that the ground under the stand is level and firm.◀

- Switch off the engine.
- Dismount and keep your left hand on left handlebar grip.
- Grasp passenger seat handle or rear frame with your right hand.
- Place right foot on extended arm of center stand, and press

stand down until its curved feet touch ground.

- Place full weight of body on center stand while pulling motorcycle toward rear.

! Excessive movements could result in the center stand retracting, and the motorcycle would topple as a result.

Do not sit on the motorcycle while it is resting on the center stand.◀

- Check that motorcycle is standing firmly.
- Lock steering lock.

Pushing off center stand^{OA}

- Unlock steering lock.
- Place your left hand on left handlebar grip.
- With your right hand, grip rear grab handle or rear frame.

- Push motorcycle forward off center stand.
- Make sure that center stand is fully retracted.

Refueling

! Fuel is highly flammable. Fire at the fuel tank can result in fire and explosion. Do not smoke. Never bring a naked flame near the fuel tank.◀

! Fuel expands when exposed to heat. When the tank is overfilled, fuel can escape and get onto the rear wheel. This results in a danger of falling. Do not fill the tank past the bottom edge of the filler neck.◀

! Fuel attacks plastic surfaces, making them cloudy or unattractive. Wipe off any fuel that gets onto plastic parts immediately.◀

! Fuel can attack the material of the windshield and the side wind deflectors, making them cloudy or unattractive. Wipe off any fuel that gets onto the windshield and wind deflectors immediately.◀



! Leaded fuel will destroy the catalytic converter. Use only unleaded fuel.◀

- Make sure ground is level and firm and park motorcycle.



- Open protective cap.

- Open fuel tank cap with ignition key by turning it counter-clockwise.
- Refuel with quality listed below at most until lower edge of filler neck is reached.

 Recommended fuel quality
– 95 ROZ/RON (Super unleaded)
with OE Regular unleaded (RON 91):
– 91 ROZ/RON (Regular unleaded (fuel type can be used with reduced performance and consumption))<
 Usable fuel quantity
– 4.2 gal (16 l)

 Reserve fuel quantity
– ≥ 1.1 gal (≥ 4 l)

- Press fuel tank cap down firmly to close.
- Remove key and close protective cap.

Technology in detail

Brake system with BMW Motorrad ABS ^{OE}	72
Tire Pressure Control TPC ^{OE}	74

Brake system with BMW Motorrad ABS^{OE}

How does ABS work?

The maximum braking force that can be transferred to the road surface is partially dependent on the friction coefficient of the road surface. Gravel, ice, snow and wet roads offer a considerably poorer friction coefficient than a dry, clean asphalt surface. The poorer the friction coefficient of the road surface is, the longer the braking distance will be. If the maximum transferrable braking force is exceeded when the driver increases the brake pressure, the wheels begin to block and driving stability is lost, and a fall can result. Before this situation occurs, ABS intervenes and adjusts the brake pressure to the maximum transferrable braking force. This enables the wheels to continue to turn and

maintains driving stability regardless of the road surface condition.

What happens when rough roads are encountered?

Bumpy or rough roads can briefly lead to a loss of contact between the tires and the road surface, until the transferrable braking force is reduced to zero. If braking is carried out in this situation, ABS must reduce the brake pressure to ensure driving stability when restoring contact to the road. At this point in time, the BMW Motorrad ABS must assume extremely low friction coefficients (gravel, ice, snow) so that the running wheels turn in every imaginable case and the driving stability is ensured. After detecting the actual conditions, the system adjusts the optimum brake pressure.

Lifting off rear wheel

Even during severe braking, a high level of tire grip can mean that the front wheel does not lock up until very late, if at all. Consequently, ABS does not intervene until very late, if at all. Under these circumstances the rear wheel can lift off the ground, and the outcome can be a high-siding situation in which the motorcycle can flip over.



Heavy braking can lead to the rear wheel lifting off the ground.

When braking, bear in mind that the ABS control cannot be relied on in all circumstances to prevent the rear wheel from lifting off the ground. ◀

What are the design characteristics of the BMW Motorrad ABS?

The BMW Motorrad ABS ensures driving stability on any surface within the limits of driving physics. The system is not optimized for special requirements resulting under extreme weather conditions offroad or on the racetrack.

Special situations

To detect the tendency of the wheels to lock up, the speeds of the front and rear wheel are compared. If implausible values are detected over a longer period of time, the ABS function is deactivated for safety reasons and an ABS fault is indicated. The condition for a fault message is the completed self-diagnosis. In addition to problems on the BMW Motorrad ABS, unusual

driving conditions can also lead to a fault message.

Unusual driving conditions:

- Driving on the rear wheel (wheely) for a longer period.
- Rear wheel spinning in place with front brake pulled (burn out).
- Heating up on the main or auxiliary stand at idle or with gear engaged.
- Locked-up rear wheel for a longer period of time, e.g. when riding downhill offroad.

Should a fault message result due to one of the driving conditions described above, the ABS function can be reactivated by switching the ignition off and then on again.

How important is regular maintenance?



Any technical system is always only as good as its maintenance condition.

To ensure that the BMW Motorrad ABS is in an optimally maintained condition, it is vital that the specified inspection intervals be complied with. ◀

Reserves for safety

But remember: the potentially shorter braking distances which BMW Motorrad ABS permits must not be used as an excuse for careless riding. ABS is primarily a means of ensuring a safety margin in genuine emergencies.

Take care when cornering. When you apply the brakes on a corner, the motorcycle's weight and momentum take over and even

BMW Motorrad ABS is unable to counteract their effects.

Tire Pressure Control TPC^{OE}

Function

A sensor is located in each tire, which measures the air temperature and the air pressure inside the tire and sends these values to the control unit.

The sensors are equipped with a centrifugal controller, which does not enable the transmission of the measured values until a speed of approx. 20 mph (30 km/h) is reached. Before initial reception of the tire pressure, -- is shown in the display for each tire. The sensors continue to transmit the measured values for approx. 15 minutes after the motorcycle comes to a stop.

The control unit can manage four sensors, and as a result two sets

of wheels with TPC sensors can be driven. If a TPC control unit is installed without the wheels being equipped with sensors, an error message is output.

Temperature compensation

The tire pressures are shown temperature-compensated in the multifunction display; they refer to a tire air temperature of 68 °F (20 °C). As the air-pressure testers at filling stations show a temperature-dependent tire pressure, they do not match the values indicated in the multifunction display in most cases.

Air pressure ranges

The TPC control unit distinguishes between three air pressure ranges matched to the motorcycle:

- Air pressure within the permissible tolerance.
- Air pressure at the limits of the permissible tolerance.
- Air pressure outside the permissible tolerance.

Accessories

General instructions.....	76
Onboard socket.....	76
Luggage	77
Case ^{OA}	78
Topcase ^{OA}	81

General instructions

BMW Motorrad recommends the use of parts and accessories for your motorcycle that are approved by BMW for this purpose. Your authorized BMW Motorrad retailer is the right place to go for genuine BMW parts and accessories, other BMW-approved products, and expert advice on their installation and use.

These parts and products have been tested by BMW for safety, function and suitability. BMW accepts product liability for these products.

Conversely, BMW is unable to accept any liability whatsoever for parts and accessories which it has not approved.



BMW Motorrad cannot examine or test each product of outside origin to ensure that it can be used on or in connection with BMW motorcycles without

constituting a safety hazard. Nor is this guarantee provided when the official approval of a specific country has been granted. Tests conducted by these instances cannot make provision for all operating conditions experienced by BMW motorcycles and, consequently, they are not sufficient in some circumstances.

Use only parts and accessories approved by BMW for your motorcycle. ◀

Whenever you are planning modifications, comply with all the legal requirements. The motorcycle must not infringe on national road-vehicle construction and use regulations.

Onboard socket

Ratings

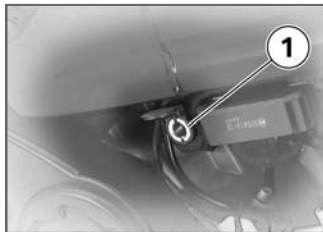

The supply to the socket **1** is cut off automatically if battery voltage is low or the load exceeds the maximum rating.

Operating electrical accessories

You can start using electrical accessories only when the ignition is switched on. The accessory remains operational if the ignition is subsequently switched off. Approx. 15 minutes after switching off the ignition and/or during

starting, the onboard socket is switched off to take the load off the vehicle electrical system.

Cable routing

The cables from the onboard socket to the auxiliary device must be routed in such a way that they:

- Do not impede the rider
- Do not restrict or obstruct the steering angle and handling characteristics
- Cannot be trapped



Improperly routed cables can impede the rider.

Route the cables as described above. ◀

Luggage

Correct loading



Overloading and imbalanced loads can adversely affect the motorcycle's handling. Do not exceed the gross weight

limit and observe the loading information. ◀

- Adjust setting of spring preload, damping characteristic and tire inflation pressures to suit total weight.
- Ensure that case volumes on left and right are equal.
- Make sure that weight is uniformly distributed between right and left.
- Pack heavy items of luggage downwards and inwards.
- Observe maximum payload of case and corresponding top speed.

 Payload of case
with OA Case:
- ≤18 lbs (≤8 kg)◀

 Speed limit for driving with case
with OA Case:
- ≤112 mph (≤180 km/h)◀

- Observe maximum payload of Topcase and corresponding top speed.

 Payload of Topcase
with OA Topcase:
- ≤11 lbs (≤5 kg)◀

 Speed limit for driving with Topcase
with OA Topcase:
- ≤112 mph (≤180 km/h)◀

- Observe maximum payload of tank rucksack.



Payload of tank rucksack

with OA Tank rucksack:

– ≤11 lbs (≤5 kg)◁

- Observe maximum payload of tank bag.



Payload of tank bag

with OA Tank bag:

– ≤11 lbs (≤5 kg)◁

- Comply with maximum payload of luggage rack.



Payload of luggage carrier

with OA Luggage rack:

– ≤22 lbs (≤10 kg)◁

Lashing down luggage

- Removing seat (➡ 56)

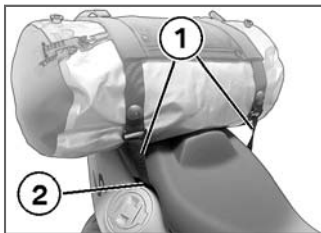

- Pull luggage belt **1** through under seat in area **2** of fuel-tank fill location. Make sure that belt is in front of bars on underside of seat.
- Installing seat (➡ 56)
- Guide luggage belt along piece of luggage in area provided to luggage rack.

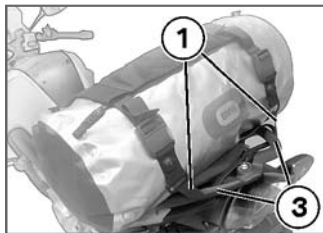

- Pull luggage belt **1** through luggage rack **3** and lash down.
- Check piece of luggage for secure hold.

Case^{OA}

Release levers

There is a release lever on the left and right of each case lock. The gray lever marked OPEN is used to open and close the cases.

The black lever marked RELEASE is used to remove and attach the cases.

Opening case

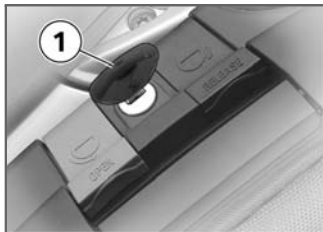

- Turn lock barrel **1** to position OPEN.

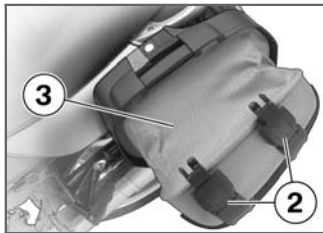

- Pull gray release lever (OPEN) upward.
» Lock straps **2** open.

- Pull gray release lever (OPEN) upward again.
- Pull case lid **3** out of retainer.
» Case completely opened.

Closing case

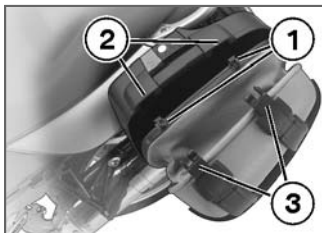

- Press catches **1** of case lid into retainers **2**.
» The catches can be heard to lock into place.
- Press catches **3** of lock straps into retainers **2**.
» The catches can be heard to lock into place.

Adjusting case volume

- Close case lid.



- Press lock straps **2** outward and pull out upward.
» Maximum volume is now set.



- Close lock straps **2**.
- Press case lid against case body.
- » Case volume is adapted to contents.

Removing case

- Turn lock barrel in direction RELEASE.
- Pull black release lever (RELEASE) upward.

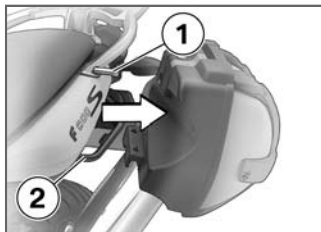

- Pull case out of upper mount **1**.
- Lift case out of lower mount **2**.

Mounting case

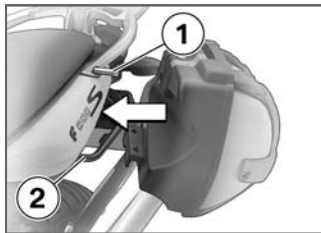

- Hook case into lower mounting **2**.

- Pull black release lever (RELEASE) upward.
- Press case into upper mounting **1**.
- Press black release lever (RELEASE) downward.
- » Case is locked into place.
- Lock case.
- Check secure attachment of case.

Secure hold

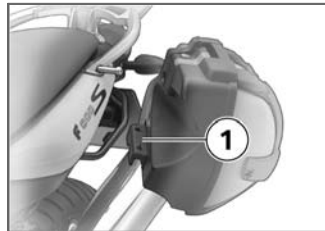

If a case wobbles or is difficult to fit, it must be adapted to the gap between the upper and lower mounting. To achieve this, the

height of the lower bracket **1** on the case can be changed.

Adapting case

- Open case.



- Unfasten screws **1**.
- Adjust height of bracket.
- Tighten screws **1**.

Topcase^{OA}

Opening Topcase

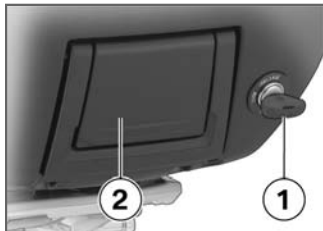

- Turn lock barrel **1** to position OPEN.
- Press lock barrel.
 - » Locking lever **2** pops out.



- Fully open locking lever **2**.
- Open lid.

Closing Topcase

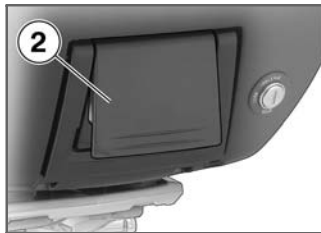

- Fully open locking lever **2**.

- Close lid and press down. Check that nothing is trapped between lid and case.
- Press locking lever **2** down.
 - » Lever audibly engages.

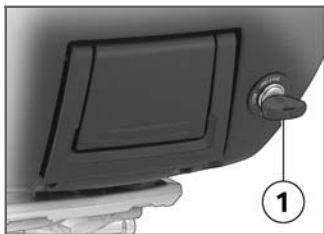

- Turn lock barrel **1** to position LOCK.
- » Topcase is locked.

Removing Topcase

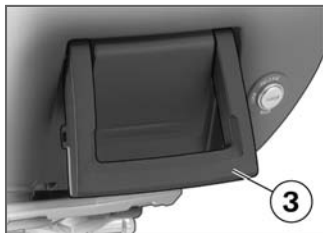

- Turn lock barrel in direction RELEASE.
- » Handle **3** pops out.
- Pull up handle **3** completely.
- Lift Topcase at rear and remove it from carrier plate.

Mounting Topcase

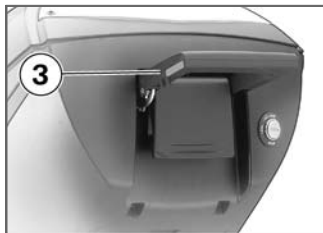

- Pull up handle **3** completely.

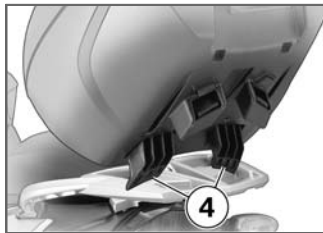

- Hook Topcase into position on carrier. Make sure that hooks **4** are securely seated in corresponding mounts.

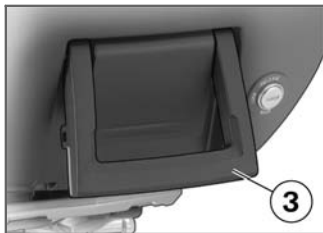

- Press down carrying handle **3** completely.
» Carrying handle audibly engages.

Maintenance

General instructions.....	86
Onboard-toolkit service set	86
Engine oil	87
General brake system.....	88
Brake pads	89
Brake fluid	91
Coolant	93
Clutch	94
Tires.....	95
Rims	95
Wheels	95
Front wheel stand	102
Rear-wheel stand	103
Lamps	104
Jump-starting.....	110

Battery.....	111
--------------	-----

General instructions

The "Maintenance" chapter describes work involving the checking and replacement of wear parts that can be performed with a minimum of effort.

If special tightening torques are to be taken into account for assembly, these are listed. An overview of all required tightening torques is contained in the chapter "Technical Data".

Information on additional maintenance and repair work is provided in the Repair Manual for your motorcycle on DVD/CD-ROM (RepROM), which you can obtain from your authorized BMW Motorrad retailer.

Special tools and a thorough knowledge of motorcycles are required to carry out some of the work described here. If you are in doubt, consult a certified work-

shop, preferably your authorized BMW Motorrad retailer.

Onboard-toolkit service set

Your BMW Motorrad retailer offers the onboard-toolkit service set for additional work.

Information on conducting this work is provided in the Repair Manual on DVD/CD-ROM, which is also available from your BMW Motorrad retailer.

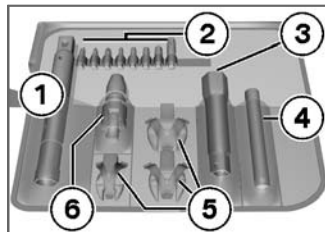

1 Pull-out tool holder

- Holding of all tools with adapter
- Removing and installing spark plugs

2 1/4" bits

- 5x Torx, e.g. removing and installing rear wheel
- 2x Phillips
- 1x Straight-blade

3 3/8" Allen key, 22 mm

- Removing and installing front axle

4 Flashlight

- LED technology

5 Socket wrench

- 3x open-ended wrench, e.g. removing and installing battery terminals

6 Adapter

- Mounting for 1/4" bits
- 9x12 mm and 3/8" jointed adapter

Engine oil

Checking engine oil level

 The engine can seize if the oil level is low, and this can lead to accidents.

Always make sure that the oil level is correct.◀

 The oil level varies with the temperature of the oil. The higher the temperature, the higher the level of oil in the sump. Checking the oil level with the

engine cold or after a short trip leads to misinterpretations and therefore to incorrect oil fill quantities.

To ensure that the display of the engine oil level is correct, only check the oil level after a longer trip.◀

- Wipe area around oil fill location clean.
 - Allow engine to idle until fan starts up, then allow to continue running for an additional minute.
 - Switch off the engine.
 - Make sure ground is level and firm and hold motorcycle at operating temperature vertically.
- with OA Center stand:
- Make sure ground is level and firm and place motorcycle at operating temperature on its center stand.<

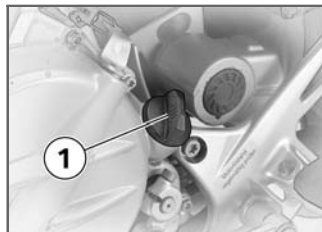

- Remove oil dipstick **1** by turning counterclockwise.

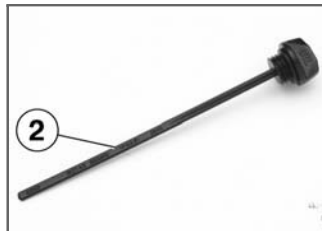

- Clean measuring range **2** of oil dipstick with a dry cloth.
- Place oil dipstick on oil fill location, but do not install.

- Remove oil dipstick and read off oil level.



Engine oil level

- between MIN and MAX markings on oil dipstick
- 0.4 quarts (0.4 l) (Difference between MIN and MAX)

If oil level is below MIN mark:

- Topping up engine oil (➡ 88)

If oil level is above MAX mark:

- Have oil level corrected by a specialized workshop, preferably an authorized BMW Motorrad retailer.

Topping up engine oil



Both too little and too much engine oil can lead to engine damage.

Always make sure that the oil level is correct. ◀

- Wipe area around fill location clean.
- Remove oil dipstick.

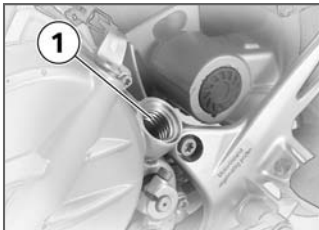

- Top up engine oil up to specified level via fill location **1**.
- Checking engine oil level (➡ 87)
- Install oil dipstick.

General brake system

Brake safety

A fully functional brake system is a basic requirement for the road safety of your motorcycle.

Do not ride the motorcycle if you have any doubts about the dependability of the brake system. In this case, have the brake system checked by a specialized workshop, preferably by an authorized BMW Motorrad retailer.



Incorrect working practices endanger the reliability of the brakes.

Have all work on the brake system performed by a specialized workshop, preferably by an authorized BMW Motorrad retailer. ◀

Checking brake operation

- Pull handbrake lever.
 - » Pressure point must be clearly perceptible.
- Press footbrake lever.
 - » Pressure point must be clearly perceptible.

If no clear pressure points are perceptible:

- Have the brakes checked by a certified workshop, preferably an authorized BMW Motorrad dealer.

Brake pads

Checking front brake pad thickness



Dropping below the minimum pad thickness leads to reduced braking performance and may result in damage to the brakes.

In order to ensure the operating reliability of the brake system, make sure that the brake pads are not worn beyond their minimum thickness. ◀

- Make sure ground is level and firm and park motorcycle.

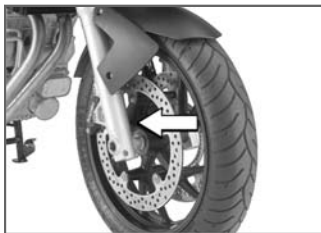

- Visually inspect the left and right brake pads to ascertain their thickness. Direction of view: between wheel and fork tube at brake caliper.

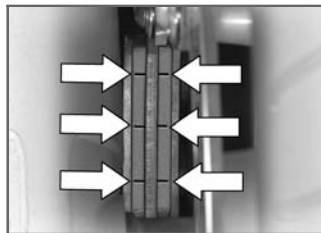

Front brake-pad wear limit

– min 0.04 in (min 1 mm) (Only friction material without carrier plate)

– Wear marking (grooves) must be clearly visible.

If the wear indicating marks are no longer clearly visible:

- Have the brake pads replaced by a specialized workshop, preferably an authorized BMW Motorrad retailer.

Checking rear brake pad thickness

 Dropping below the minimum pad thickness leads to reduced braking performance and may result in damage to the brakes.

In order to ensure the operating reliability of the brake system, make sure that the brake pads are not worn beyond their minimum thickness. ◀

- Make sure ground is level and firm and park motorcycle.

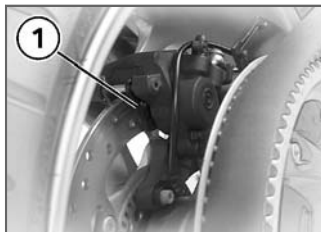

- Visually check brake pad thickness **1** from rear.

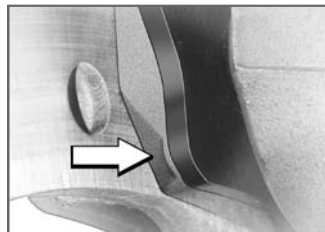

Rear brake-pad wear limit

– min 0.04 in (min 1 mm) (Only friction material without carrier plate)

– Wear indicators must be clearly visible.

If the wear indicating mark is no longer visible:

- Have brake pads replaced by a specialized workshop, preferably an authorized BMW Motorrad retailer.

Brake fluid

Checking front brake fluid level

 A low fluid level in the brake reservoir can allow air to penetrate the brake system. This significantly reduces braking efficiency.

Check brake fluid level regularly. ◀

- Make sure ground is level and firm and hold motorcycle vertically.

with OA Center stand:

- Make sure ground is level and firm and place motorcycle on its center stand. ◀
- Move handlebars into straight-ahead position.

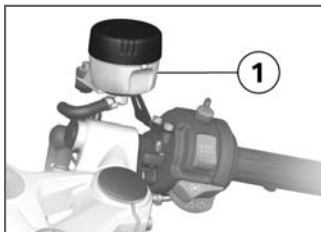

- Read off brake fluid level at front brake-fluid reservoir **1**.

 The brake fluid level in the brake-fluid reservoir drops due to brake pad wear. ◀



 Front brake fluid level

– Brake fluid DOT4

– The brake fluid level must not fall below the MIN mark.

If brake fluid level drops below permissible level:

- Have the defect corrected as soon as possible by a specialized workshop, preferably an authorized BMW Motorrad retailer.

Checking rear brake fluid level

! A low fluid level in the brake reservoir can allow air to penetrate the brake system. This significantly reduces braking efficiency. Check brake fluid level regularly.◀

- Make sure ground is level and firm and hold motorcycle vertically with OA Center stand:
- Make sure ground is level and firm and place motorcycle on its center stand.◁

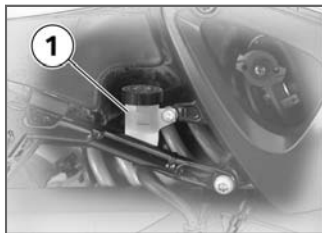

- Read off brake fluid level at rear brake-fluid reservoir **1**.
- ▶ The brake fluid level in the brake-fluid reservoir drops due to brake pad wear.◀



 Rear brake fluid level

– Brake fluid DOT4

– The brake fluid level must not fall below the MIN mark.

If brake fluid level drops below permissible level:

- Have the defect corrected as soon as possible by a specialized workshop, preferably an authorized BMW Motorrad retailer.

Coolant

Checking coolant level

- Make sure ground is level and firm and park motorcycle.

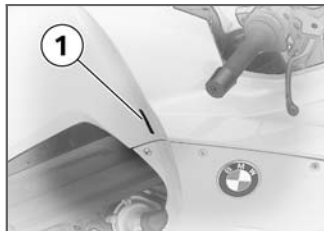

- Check coolant level on scale **1** of coolant reservoir.

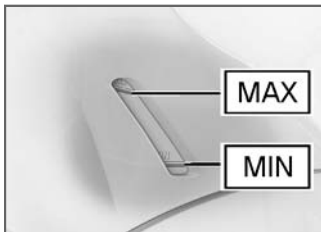

Coolant level

– between MIN and MAX marks on the expansion tank

If coolant level is too low:

- Add coolant.

Topping up coolant

- Removing battery compartment cover (➔ 113)

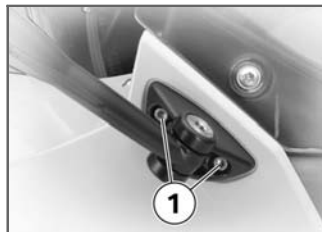

- Remove screws **1** of right mirror.
- Remove mirror.

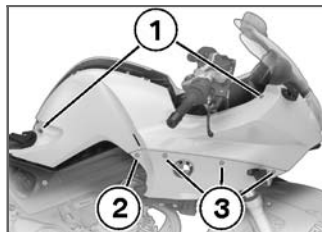

- Remove two screws **1**.
- Remove short screw **2**.
- Remove three screws **3**.

- Remove side panel upward.

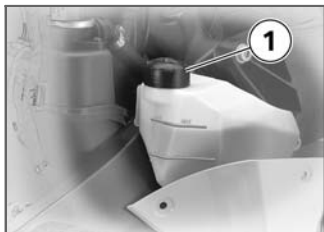

- Open cap **1** of coolant fill location by turning counterclockwise.
- Pour in coolant up to specified level.
- Close cap of coolant fill location by turning clockwise.

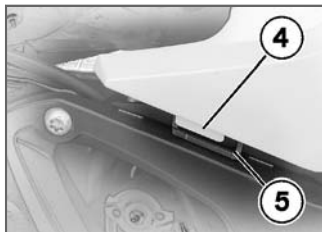

- Push side section behind lower side panel while making sure that guide **4** of side section grips into mount **5**.

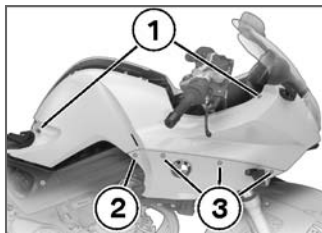

- Install three screws **3**.
- Install short screw **2**.

- Install two screws **1**.

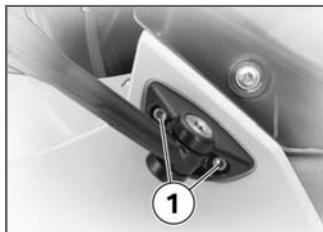

- Position mirror.
- Install screws **1**.
- Installing battery compartment cover (➔ 113)

Clutch

Checking clutch operation

- Pull the clutch lever.
- » Pressure point must be clearly perceptible.

If no clear pressure point can be felt:

- Have the clutch checked by a specialized workshop, prefer-

ably an authorized BMW Motorrad retailer.

Tires

Checking tire tread depth



The handling of your motorcycle can already change for the worse before the legally prescribed minimum tread depth is reached.

Have tires replaced even before the minimum tread depth is reached.◀

- Make sure ground is level and firm and park motorcycle.
- Measure tire tread depth in main tread grooves with wear indicating marks.

 Tires have wear indicators integrated into the main tread grooves. If the tire tread has worn down to the level of the marks, the tire is completely worn. The locations of the marks are indicated on the edge of the

tire, e.g. by the letters TI, TWI or by an arrow.◀

If the tire tread depth no longer complies with the legally required minimum tread depth:

- Replace tire.

Rims

Visual inspection

- Make sure ground is level and firm and park motorcycle.
- Visually inspect rims for defects.
- Have damaged rims checked and, if necessary, replaced by a specialized workshop, preferably an authorized BMW Motorrad retailer.

Wheels

Approved wheels and tires

For every size of tire, BMW Motorrad has tested certain makes and approved those it has found to be roadworthy. If you use wheels and tires that have not been approved, BMW Motorrad cannot assess their suitability or provide any guarantee as to their road safety.

Use only wheels and tires that BMW Motorrad has approved for your type of motorcycle.

Extensive information is available at your authorized BMW Motorrad retailer or on the Internet at www.bmw-motorrad.com.

TPC sticker^{OE}

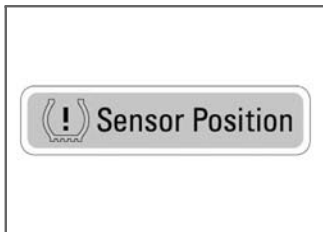

! The TPC sensors can be damaged by improper tire mounting.

Inform the BMW Motorrad retailer or the specialized workshop that the wheel is equipped with a TPC sensor. ◀

On motorcycles equipped with TPC, a corresponding sticker is located on the wheel rim at the position of the TPC sensor. During a tire change it must be ensured that the TPC sensor is not damaged. Inform the BMW Mo-

torrad retailer or the specialized workshop of the TPC sensor.

Removing front wheel

- Place motorcycle on an auxiliary stand; BMW Motorrad recommends BMW Motorrad rear wheel stand.
 - Installing rear-wheel stand (➔ 103)
- with OA Center stand:
- Place motorcycle onto center stand. ◀

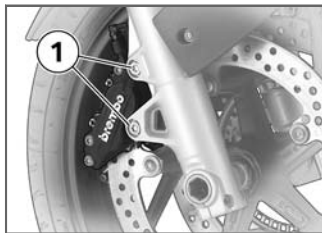

! Once the calipers have been removed, there is a risk of the brake pads being

pressed together to the extent that they cannot be slipped back over the brake disk on reassembly.

Do not operate the handbrake lever when the brake calipers have been removed. ◀

- Remove mounting bolts **1** of brake calipers on left and right.

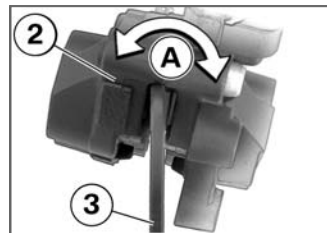

- Press brake pads in brake caliper **2** apart slightly by rocking back and forth **A** in relation to brake disks **3**.

- Mask off area of wheel rim that could be scratched in process of removing brake calipers.
- Carefully pull brake calipers back and out until clear of brake disks.

with OE BMW Motorrad ABS:

- When pulling off left brake caliper, make sure that ABS sensor cable is not damaged.<
- Raise front of motorcycle until the front wheel can turn freely. BMW Motorrad recommends the BMW Motorrad front-wheel stand for lifting the motorcycle.
- Mounting front wheel stand (➡ 102)

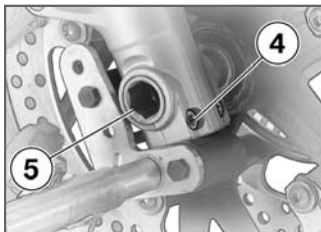

- Remove axle clamping screw **4**.
- Remove quick-release axle **5** while supporting wheel.
- Roll front wheel forward to remove.

with OE BMW Motorrad ABS:

- When rolling out wheel, watch ABS sensor on left side.<

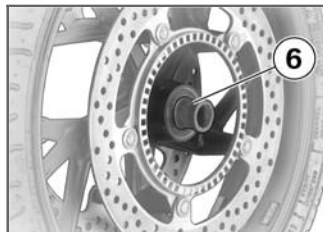

- Remove spacing bushing **6** on left side from wheel hub.

Installing front wheel



Threaded fasteners not tightened to the specified torque can work loose or their threads can suffer damage.

Always have the tightening torques checked by a specialized workshop, preferably an authorized BMW Motorrad retailer.◀



During the following work, parts of the front brake, in

particular of the BMW Motorrad ABS, can be damaged.

Take care not to damage the brake system, in particular the ABS sensor with cable and the ABS sensor ring. ◀

 The front wheel must be installed right way round to rotate in the correct direction. Observe the direction of rotation arrows on the tires or on the rim. ◀

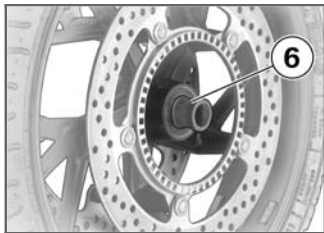

- Mount spacing bushing **6** on left side on wheel hub.
- Roll front wheel into front forks.

with OE BMW Motorrad ABS:

- When rolling in wheel, watch ABS sensor on left side. ◀

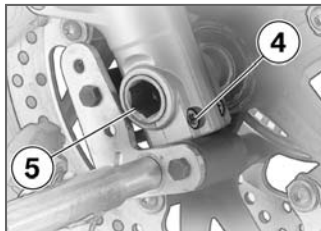

- Lift front wheel and install quick-release axle **5** with appropriate torque.



Quick-release axle in axle mount

– 37 lb/ft (50 Nm)

- Tighten axle clamping screw **4** with appropriate torque.



Pinch bolt of quick-release axle

– 15 lb/ft (20 Nm)

- Remove front wheel stand.
- Ease brake calipers onto brake disks.

with OE BMW Motorrad ABS:



 The cable of the ABS sensor could chafe through if it comes into contact with the brake disk. Ensure installation of the ABS sensor cable close to the front suspension. ◀

- Route ABS sensor cable **2** as shown in picture.◁

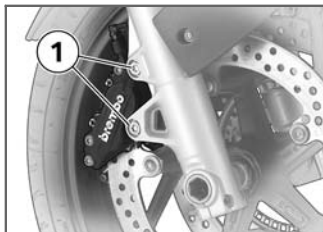

- Tighten mounting screws **1** with appropriate torque.



Brake caliper on slider tube

– 22 lb/ft (30 Nm)

- Remove adhesive tape from wheel rim.
- Operate brakes several times until brake pads contact brake disk.

Removing rear wheel

- Place motorcycle on an auxiliary stand; BMW Motorrad recommends BMW Motorrad rear wheel stand.
- Installing rear-wheel stand (103) with OA Center stand:
- Place motorcycle onto center stand.◁

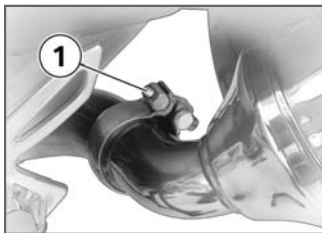

- Loosen screw **1** on muffler.
- Do not remove sealing grease from clamp.

- Support exhaust manifold with suitable object (e.g. wooden block).



- Remove screw **2** for bracket of muffler from passenger footrest.

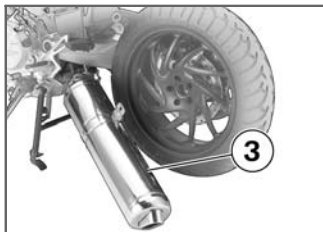

- Turn muffler **3** downward and lay aside.
- Shift into first gear.

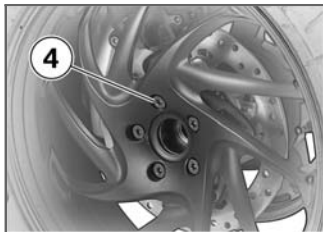

- Remove mounting bolts **4** of rear wheel, holding wheel as you do so.

- Lower rear wheel to ground.
- Roll rear wheel out toward rear.

Installing rear wheel

 Threaded fasteners not tightened to the specified torque can work loose or their threads can suffer damage. Always have the tightening torques checked by a specialized workshop, preferably an authorized BMW Motorrad retailer. ◀

- Roll rear wheel onto rear wheel support.
- Place rear wheel on rear wheel support.

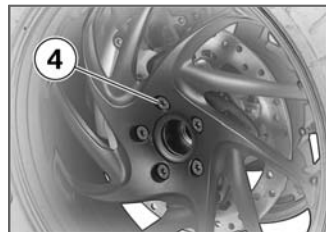

- Tighten wheel bolts **4** diagonally with specified torque.

	Rear wheel on drive shaft
– 44 lb/ft (60 Nm)	

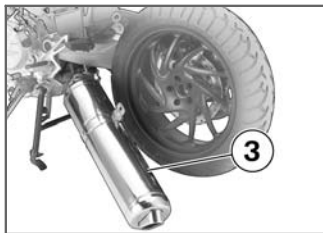

- Turn muffler **3** to its initial position.

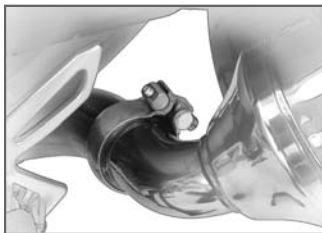

- Tighten clamp on muffler to appropriate torque.

 Muffler on manifold
- 26 lb/ft (35 Nm)



- Tighten screw **2** for bracket of muffler on passenger footrest with appropriate torque.

 Muffler on rear frame
- 14 lb/ft (19 Nm)



- Install screw **2** for muffler bracket in rear footrest, but do not tighten it at this point.

Front wheel stand

Use

A front-wheel stand for simple, safe changing of the front wheel is available from BMW Motorrad. The front wheel stand with the BMW special tool number 36 3 970 can be obtained from your authorized BMW Motorrad retailer.

! The BMW Motorrad front wheel stand is not designed for holding motorcycles without a center or other auxiliary stands. A motorcycle standing on the front wheel stand and the rear wheel alone can fall over.

Place the motorcycle on the center stand or an auxiliary stand before lifting it with the BMW Motorrad front wheel stand.◀

Mounting front wheel stand

- Place motorcycle on an auxiliary stand; BMW Motorrad recommends BMW Motorrad rear wheel stand.
- Installing rear-wheel stand (➔ 103) with OA Center stand:
- Place motorcycle onto center stand.◀

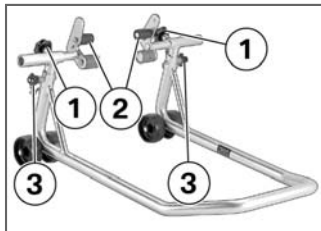

- Loosen adjusting screws **1**.
- Push two mounts **2** far enough apart that front forks fit between them.

- Use locating pins **3** to set front wheel stand to desired height.
- Center front wheel stand relative to front wheel and push it against front axle.

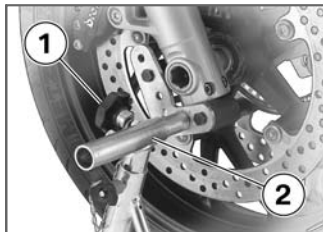

- Align two mounts **2** so that front forks rest securely on them.
- Tighten adjusting screws **1**.



- Apply uniform pressure to push front wheel stand down and raise motorcycle.

Rear-wheel stand

Use

In order to be able to work safely on motorcycles without center stands, BMW Motorrad offers a rear wheel stand. This rear wheel stand with the BMW special tool number 36 3 980 can be obtained from your authorized BMW Motorrad retailer.

Installing rear-wheel stand

- Make sure ground is level and firm and park motorcycle.

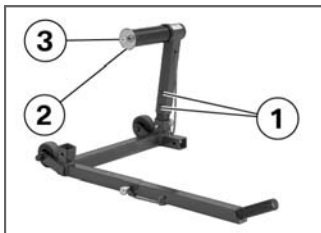

- Set desired height of rear wheel stand using bolts **1**.
- Remove lock washer **2**; to do so, press unlock button **3**.



- Push rear-wheel stand from right onto rear axle.
- Apply retaining disk from left; to do so, press unlock button.
- Place your left hand on passenger grab handle of motorcycle and your right hand on lever of rear wheel stand **4**.



- Raise motorcycle while simultaneously pressing lever downward until motorcycle stands vertically.
- Press lever onto ground.

Lamps

General instructions

A bulb failure is signaled to you in the multifunction display by a warning indicator.

 A defective bulb places your safety at risk because it is easier for other users to oversee the motorcycle. Replace defective bulbs as

soon as possible; always carry a complete set of spare bulbs if possible. ◀

 The bulb is pressurized and can cause injury if damaged.

Wear eye and hand protection when replacing bulbs. ◀

 An overview of the bulb types installed in your motorcycle is provided in the chapter "Technical Data". ◀

 Do not touch the glass of new bulbs with your fingers. For installation, use a clean, dry cloth. Dirt deposits, in particular oil and grease, interfere with heat radiation from the bulb. Overheating and therefore short service life of the bulbs are the consequence. ◀

Replacing high-beam/low-beam bulb

 If it is not standing firmly, the motorcycle could topple in the course of the operations described below.

Make sure that the motorcycle is steady on its stand. ◀

- Make sure ground is level and firm and park motorcycle.
- Switch off ignition.

 To achieve better accessibility, turn the handlebars to the left. ◀

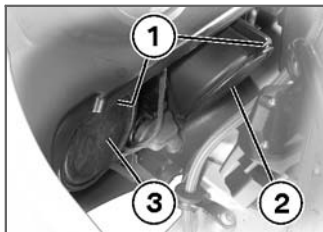

- Remove cover **2** (low beam) or cover **3** (high beam) by pulling on lever **1**.

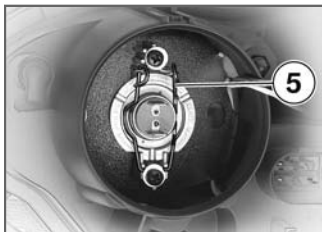

- Remove spring strap **5** from detents and fold to side.

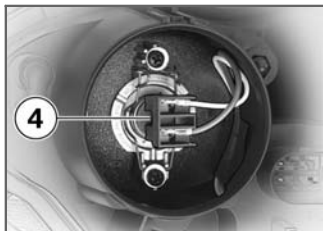

- Disconnect plug **4**.

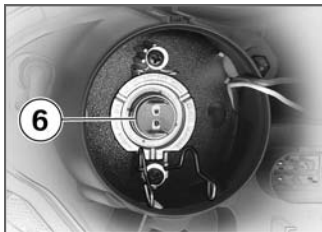

- Remove bulb **6**.
- Replace defective bulb.

	Bulb for high-beam headlight
- H7 / 12 V / 55 W	

	Bulb for low-beam headlight
- H7 / 12 V / 55 W	



- Install bulb while ensuring correct position of lug **7** (high beam bottom/low beam top) and make sure that bulb is properly engaged.

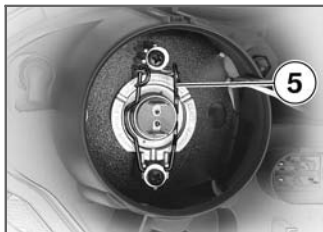

- Close and lock spring strap **5**.

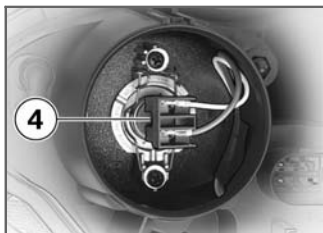

- Close connector **4**.

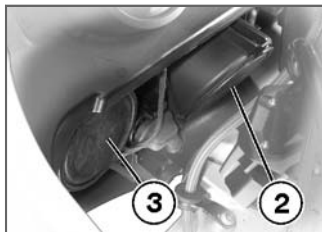

- Install cover **2** (low beam) or cover **3** (high beam).

Replacing parking light bulb

⚠ If it is not standing firmly, the motorcycle could topple in the course of the operations described below.

Make sure that the motorcycle is steady on its stand. ◀

- Make sure ground is level and firm and park motorcycle.
- Switch off ignition.

▶ To achieve better accessibility, turn the handlebars to the left. ◀

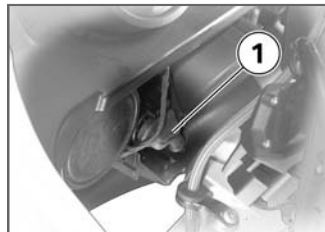

- Take off cover cap **1**.

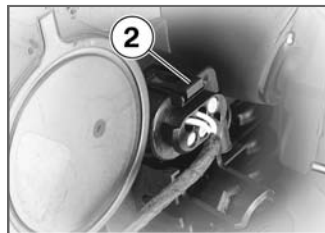

- Disconnect connector **2**.



- Remove bulb socket **3** by turning counterclockwise.

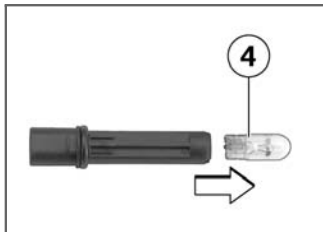

- Remove bulb **4** from bulb holder.
- Replace defective bulb.



Bulb for parking light

- W5W / 12 V / 5 W

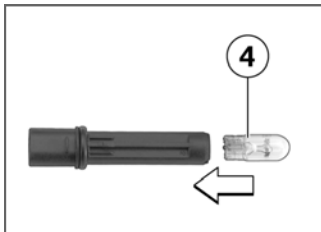

- Press bulb **4** into socket.



- Install bulb socket **3** by turning clockwise.

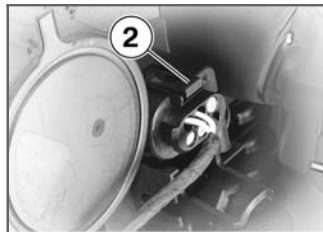

- Close connector **2**.

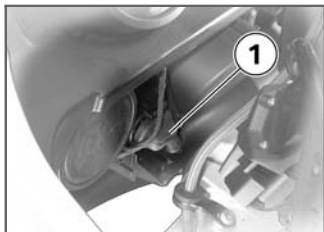

- Install cap **1**.

Replacing brake light and tail light bulbs

 If it is not standing firmly, the motorcycle could topple in the course of the operations described below.

Make sure that the motorcycle is steady on its stand. ◀

- Make sure ground is level and firm and park motorcycle.
- Switch off ignition.

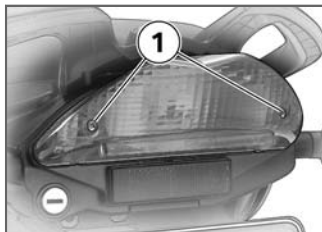

- Remove screws **1**.
- Pull off light housing toward rear.

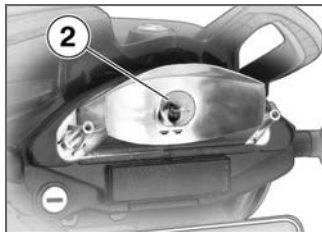

- Press bulb **2** into socket and turn counterclockwise to remove.

- Replace defective bulb.

 Bulb for taillight/brake light

– P21/5W / 12 V / 5 W / 21 W

- Use a clean, dry cloth to hold new bulb.

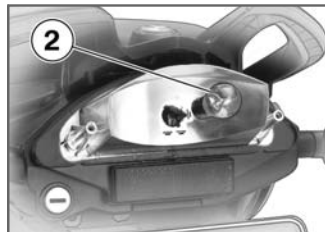

- Press bulb **2** into fitting and install turning clockwise.

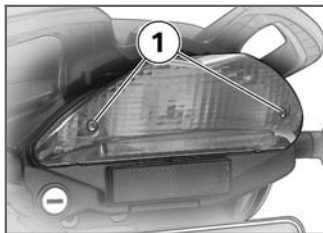

- Install light housing with screws **1**.

Replacing front or rear turn indicator bulbs



- Remove screw **1**.

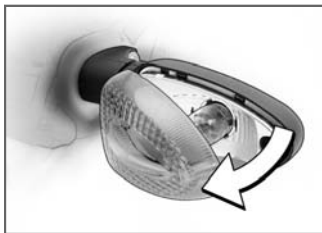

- Pull glass on screw connection side out of mirror housing.

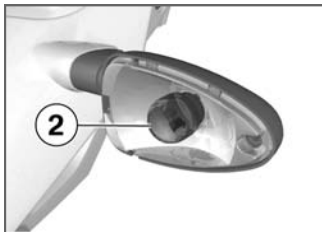

- Remove bulb **2** from light housing by turning it counterclockwise.
- Replace defective bulb.

	Bulbs for flashing turn indicators, front
– R10W / 12 V / 10 W	
with OE White turn indicators:	
– RY10W / 12 V / 10 W◁	

	Bulbs for flashing turn indicators, rear
– R10W / 12 V / 10 W	
with OE White turn indicators:	
– RY10W / 12 V / 10 W◁	

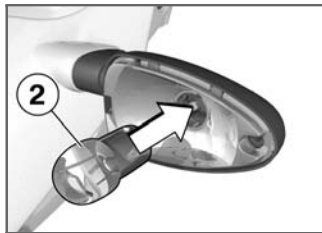

- Install bulb **2** by turning clockwise in light housing.

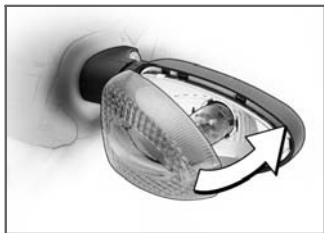

- Insert inside end of lens into light housing and close.



- Install screw **1**.

Jump-starting

 The wires leading to the power socket do not have a load-capacity rating adequate for jump-starting the engine. Excessively high current can lead to a cable fire or damage to the motorcycle electronics.

Do not use the onboard socket to jump-start the engine of the motorcycle. ◀

 Touching live parts of the ignition system with the engine running can cause electric shock.

Do not touch parts of the ignition system when the engine is running. ◀

 A short-circuit can result if the crocodile clips of the jump leads are accidentally brought into contact with the motorcycle.

Use only jump leads fitted with

fully insulated crocodile clips at both ends. ◀

 Jump-starting with a donor-battery voltage higher than 12 V can damage the motorcycle electronics.

The battery of the donor vehicle must have a voltage of 12 V. ◀

- Removing battery compartment cover (➡ 113)
- When jump-starting the engine, do not disconnect the battery from the onboard electrical system.

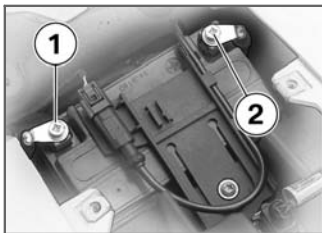

- Run engine of donor vehicle during jump-starting.
- Begin by connecting one end of the red jump lead to the positive terminal **2** of the discharged battery and the other end to the positive terminal of the donor battery.
- Connect the black jump lead to the negative terminal of the donor battery and then to the negative terminal **1** of the discharged battery.
- Start engine of motorcycle with discharged battery in usual way; if engine refuses to start, wait a few minutes before re-

peating attempt to protect starter and supporting battery.

- Allow both engines to idle for a few minutes before disconnecting jumper cables.
- First disconnect jump lead from negative terminal **1**, then from positive terminal **2**.

 To start the engine, do not use start sprays or similar items. ◀

- Installing battery compartment cover (➡ 113)

Battery

Maintenance instructions

Correct upkeep, recharging and storage will prolong the life of the battery and are essential if warranty claims are to be considered.

Compliance with the points below is important in order to maximize battery life:

- Keep the surface of the battery clean and dry
- Do not open the battery
- Do not top up with water
- Be sure to read and comply with the instructions for charging the battery on the following pages
- Do not turn the battery upside down

 If the battery is not disconnected, the onboard electronics (clock etc.) will drain the battery. This can cause the battery to run flat. If this happens, warranty claims will not be accepted.

During periods when the motorcycle is not being used, of more than four weeks, disconnect the battery from the motorcycle or connect a trickle charger to the battery. ◀

 BMW Motorrad has developed a trickle-charger specially designed for compatibility with the electronics of your motorcycle. Using this charger, you can keep the battery charged during long periods when the motorcycle is not being used without having to disconnect the battery from the motorcycle's onboard systems. Additional information is available at your authorized BMW Motorrad retailer.◀

Charging connected battery

 Charging the connected battery directly at the battery terminals can damage the motorcycle electronics. To charge the battery via the battery terminals, disconnect the battery first.◀

 Charging the battery via the onboard socket is only possible with suitable chargers. Unsuitable chargers can result in damage to the motorcycle electronics. Use BMW chargers with the part numbers 71 60 7 688 864 (220 V) or, as applicable, 71 60 7 688 865 (110 V). If in doubt, charge the disconnected battery directly at the terminals.◀

 If you switch on the ignition and the multifunction display and indicator lights fail to light up, the battery is completely flat. Attempting to charge a completely flat battery via the onboard socket can cause damage to the motorcycle's electronics. Always charge a completely drained battery directly at the terminals of the disconnected battery.◀

- Charge disconnected battery via onboard socket.
- Comply with the operating instructions of the charger.

 The motorcycle's onboard electronics know when the battery is fully charged. The onboard socket is switched off when this happens.◀

Charging disconnected battery

- Charge battery using a suitable charger.
- Comply with the operating instructions of the charger.
- Once the battery is fully charged, disconnect the charger's terminal clips from the battery terminals.

 In the case of longer periods when the motorcycle is not being used, the battery must be recharged regularly. See the instructions for caring for your

battery. Always fully recharge the battery before returning it to use.◀

Removing battery compartment cover

- Removing seat (➡ 56)

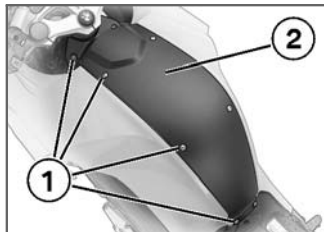

- Remove four screws **1** on left and right and take off battery compartment cover **2**.

Installing battery compartment cover

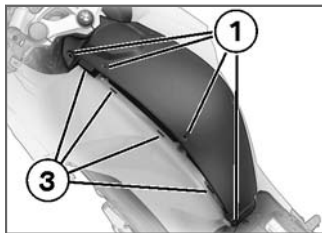

- Install battery compartment cover in guides **3** on left and right.
- Install four screws **1** on left and right.
- Installing seat (➡ 56)

Removing battery

- Make sure ground is level and firm and park motorcycle.
- Switch off ignition.
- Removing battery compartment cover (➡ 113)

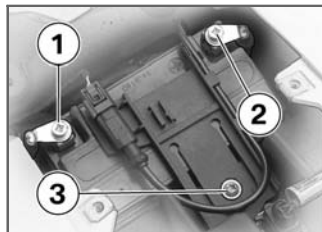

! An incorrect disconnection sequence increase the risk of short-circuiting. Always observe the proper sequence.◀

- Remove negative cable **1** first.
- Then remove positive cable **2**.
- Remove screw **3** and take off battery retaining strap.
- Lift battery up and out, using tilting movements if it is difficult to move.

Installing battery

- Switch off ignition.

- Insert battery into battery compartment, with positive terminal on right in direction of travel.

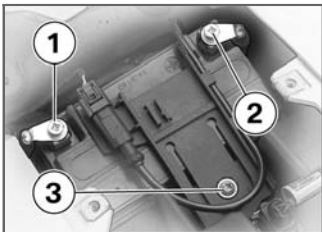

- Push battery retaining strap over battery and install screw **3**.



An incorrect connection sequence increases the risk of short-circuiting. Always observe the proper sequence.◀

- Install positive cable **2**.
- Install negative cable **1**.

▶ If the motorcycle was disconnected from the battery for a longer time, the current date must be entered in the instrument cluster to ensure the proper operation of the service display.

Consult a certified workshop, preferably an authorized BMW Motorrad retailer, for setting of the date.◀

- Installing battery compartment cover (➡ 113)
- Setting clock (➡ 40)

Care

Care products	116
Washing your motorcycle	116
Cleaning sensitive motorcycle parts	116
Paint care	117
Protective wax coating	118
Storing motorcycle.....	118
Returning motorcycle to use	118

Care products

BMW Motorrad recommends that you use cleaning and care products available at your authorized BMW Motorrad retailer. BMW Care Products have been materials tested, laboratory tested, and field tested and provide optimum care and protection for the materials used in your motorcycle.

 The use of unsuitable cleaning and care products can damage motorcycle components.

For cleaning, do not use any solvents such as nitro-thinners, cold cleaning agents, fuel or similar, and do not use cleaning agents that contain alcohol.◀

Washing your motorcycle

BMW Motorrad recommends that you use BMW Insect Remover to soften and wash off insects and stubborn dirt from painted parts before washing the motorcycle.

To prevent stains, do not wash the motorcycle immediately after it has been exposed to bright sunlight and do not wash it in the sun.

Make sure that the motorcycle is washed frequently, especially during the winter months.

To remove road salt, clean the motorcycle with cold water immediately after every trip.

 After washing the motorcycle, after driving through water or in the rain, braking can be delayed due to damp brake disks and brake pads.

Brake early until the brakes are dry or braked until dry.◀

 Warm water intensifies the effect of salt.

Only use cold water to remove road salt.◀

 The high pressure of steam cleaners can damage seals, the hydraulic brake system, the electrical system and the seat. Do not use a steam jet or high-pressure cleaning equipment.◀

Cleaning sensitive motorcycle parts

Plastics

Clean plastic parts with water and BMW plastic care emulsion. This includes in particular:

- Windshields and wind deflectors
- Headlight lens made of plastic
- Covering glass of the instrument cluster

– Black, unpainted parts

 If plastic parts are cleaned using unsuitable cleaning agents, the surfaces can be damaged.

Do not use cleaning agents that contain alcohol, solvents or abrasives to clean plastic parts. 'Fly sponges' or sponges with hard surfaces can also lead to scratches.◀

 Soften stubborn dirt and dead insects by covering the affected areas with a wet cloth.◀

Windshield

Clean off dirt and insects with a soft sponge and plenty of water.

 Fuel and chemical solvents attack the windshield material; the windshield becomes cloudy or dull.

Do not use cleaning agents.◀

Chrome

Especially in the case of road salt, carefully clean chrome parts with plenty of water and BMW auto shampoo. Use chrome polish for additional treatment.

Radiator

Clean the radiator regularly to prevent overheating of the engine due to inadequate cooling. For example, use a garden hose with low water pressure.

 Cooling fins can be bent easily.

When cleaning the radiator, ensure that the fins are not bent.◀

Rubber

Treat rubber components with water or BMW rubber protection coating agent.

 Using silicone sprays for the care of rubber seals can cause damage.

Do not use silicon sprays or other care products that contain silicon.◀

Paint care

Washing the motorcycle regularly will help counteract the long-term effects of substances that damage the paint, especially if your motorcycle is ridden in areas with high air pollution or natural sources of dirt, e.g. tree resin or pollen.

However, remove particularly aggressive materials immediately; otherwise changes in the paint or discoloration can occur. These include spilled fuel, oil, grease, brake fluid as well as bird droppings. BMW Car Polish or BMW Paint Cleaner are recommended for this.

Contamination of the paint finish is particularly easy to see after the motorcycle has been washed. Remove this type of soiling with

cleaning naphtha or spirit on a clean cloth or cotton ball. BMW Motorrad recommends removing tar spots with BMW Tar Remover. Then add a protective wax coating to the paint at these locations.

Protective wax coating

To preserve the finish of your motorcycle, BMW Motorrad recommends using BMW Car Wax or agents that contain carnauba or synthetic waxes.

A sure sign that the paint must be protected, is the fact that water no longer pearls up on it.

Storing motorcycle

- Clean the motorcycle.
- Remove the battery.
- Spray the brake and clutch lever, the side stand pivot and, if necessary, the main stand pivot with a suitable lubricant.

- Coat bare metal and chrome-plated parts with an acid-free grease (e.g. Vaseline).
- Park the motorcycle in a dry room so that both wheels are unloaded.

▶ Before putting the motorcycle into storage, have the engine oil and the oil filter element changed by a specialist workshop, preferably an authorized BMW Motorrad retailer. Combine work for storing/returning to use with maintenance service or an inspection.◀

Returning motorcycle to use

- Remove the protective wax coating.
- Clean the motorcycle.
- Install a charged battery.
- Before starting: Observe checklist.

Technical data

Troubleshooting chart	120	Riding specifications	132
Threaded fasteners	121		
Engine	122		
Fuel	123		
Engine oil	123		
Clutch	124		
Transmission	124		
Rear-wheel drive	125		
Running gear	125		
Brakes	126		
Wheels and tires	126		
Electrical system	129		
Frame	130		
Dimensions	131		
Weights	132		

Troubleshooting chart

Engine does not start at all or is very difficult to start

Possible cause	Remedy
Emergency ON/OFF switch activated.	Emergency ON/OFF switch in operating position.
Side stand extended and gear engaged.	Retract side stand (➡ 62).
Gear engaged and clutch not operated.	Place transmission in neutral or disengage clutch (➡ 62).
Clutch disengaged with ignition switched off.	Switch on ignition first, then disengage clutch.
No fuel in tank.	Refueling (➡ 68)
Battery not adequately charged.	Charging connected battery (➡ 112)

Threaded fasteners

Front wheel	Value	Valid
Brake caliper on slider tube		
M10 x 35 - 10.9	22 lb/ft (30 Nm)	
Pinch bolt of quick-release axle		
M8 x 40	15 lb/ft (20 Nm)	
Quick-release axle in axle mount		
M24 x 1.5	37 lb/ft (50 Nm)	
Rear wheel	Value	Valid
Rear wheel on drive shaft		
M10 x 1.25	44 lb/ft (60 Nm)	
Muffler on manifold		
M8 x 60 - 10.9	26 lb/ft (35 Nm)	
Muffler on rear frame		
M8	14 lb/ft (19 Nm)	

Engine

Engine design	Two-cylinder, four-stroke engine, DOHC control with toothed chain drive, 4 valves actuated by trailing valve levers, compensating connecting rods, liquid cooling for cylinders and cylinder head. Integrated water pump, 6-speed transmission and dry-sump lubrication
Displacement	798 cc (798 cm ³)
Cylinder bore	3.2 in (82 mm)
Piston stroke	3 in (75.6 mm)
Compression ratio	12:1
Rated output	85 hp (62.5 kW), at engine speed: 8000 min ⁻¹
with OE Regular unleaded (RON 91):	83 hp (61 kW), at engine speed: 8000 min ⁻¹
with OE Power reduction:	34 hp (25 kW), at engine speed: 7000 min ⁻¹
Torque	63 lb/ft (86 Nm), at engine speed: 5800 min ⁻¹
with OE Regular unleaded (RON 91):	61 lb/ft (83 Nm), at engine speed: 5800 min ⁻¹
with OE Power reduction:	41 lb/ft (55 Nm), at engine speed: 3500 min ⁻¹
Maximum engine speed	max 9000 min ⁻¹
Idle speed	1250±50 min ⁻¹

Fuel

Recommended fuel quality	95 ROZ/RON, Super unleaded
with OE Regular unleaded (RON 91):	91 ROZ/RON, Regular unleaded (fuel type can be used with reduced performance and consumption)
Usable fuel quantity	4.2 gal (16 l)
Reserve fuel quantity	≥1.1 gal (≥4 l)

Engine oil

Engine oil, capacity	3.2 quarts (3 l), with filter change
	0.3 quarts (0.3 l), when removing swinging-arm shaft cover, additionally
Lubricant	Engine oil 15W-40
Oil grades	Mineral engine oils of the API classification SF to SH. BMW Motorrad does not recommend using oil additives, as these can worsen clutch operation. Ask your BMW Motorrad retailer for engine oils suitable for your motorcycle.

Permissible viscosity classes

SAE 10 W-40	≥-4 °F (≥-20 °C), Operation at low temperatures
SAE 15 W-40	≥14 °F (≥-10 °C)

Clutch

Clutch design	Multi-disk oil-bath clutch
---------------	----------------------------

Transmission

Transmission design	Claw-shifted 6-speed transmission integrated in engine housing
---------------------	--

Gear ratios

Transmission gear ratios	1.943 (35/68 teeth), Primary gear ratio 1:2.462 (13/32 teeth), 1st gear 1:1.750 (16/28 teeth), 2nd gear 1:1.381 (21/29 teeth), 3rd gear 1:1.174 (23/27 teeth), 4th gear 1:1.042 (24/25 teeth), 5th gear 1:0.960 (25/24 teeth), 6th gear
--------------------------	---

Rear-wheel drive

Type of final drive	Belt drive with jerk damping in its own housing
Type of rear suspension	Single-arm light-alloy cast swinging arm with rear wheel axle adjustable via eccentric

Running gear

Type of front suspension	Telescopic forks
Spring travel, front	5.5 in (140 mm), On wheel
with OE Lowered suspension:	4.3 in (110 mm), On wheel
Type of rear suspension	Single-arm light-alloy cast swinging arm with rear wheel axle adjustable via eccentric
Type of rear suspension	Directly articulated central spring strut with steplessly adjustable rebound-stage damping
Spring travel at rear wheel	5.5 in (140 mm), On wheel
with OE Lowered suspension:	4.4 in (113 mm), On wheel

Brakes

Type of front brake	hydraulically operated twin disk brake with 4-piston fixed calipers and floating brake disks
Brake-pad material, front	Sintered metal
Type of rear brake	Hydraulic 1-piston floating calipers with fixed brake disk
Brake-pad material, rear	Sintered metal

Wheels and tires

Tire combinations recommended at time of going to press (As at: 12.04.2007)	front: Bridgestone Battlax BT 014 F Radial F, 120/70 ZR17 M/C (58W) rear: Bridgestone Battlax BT 014R Radial F, 180/55 ZR17 M/C (73W)
	front: Bridgestone Battlax BT 020 F UU Radial, 120/70 ZR17 M/C (58W) rear: Bridgestone Battlax BT 020R Radial N, 180/55 ZR17 M/C (73W)
	front: Continental Conti Sport Attack, 120/70 ZR17 M/C (58W) rear: Continental Conti Sport Attack, 180/55 ZR17 M/C (73W)

	front: Dunlop Sportmax D 220 F ST P, 120/70 ZR17 M/C (58W) rear: Dunlop Sportmax D 220 ST P, 180/55 ZR17 M/C (73W)
	front: Metzeler Sporttec M-1 E, 120/70 ZR17 M/C (58W) rear: Metzeler Sporttec M-1 B, 180/55 ZR17 M/C (73W)
	front: Metzeler Roadtec Z6 Front, 120/70 ZR17 M/C (58W) rear: Metzeler Roadtec Z6 E, 180/55 ZR17 M/C (73W)
	front: Michelin Pilot Road B, 120/70 ZR17 M/C (58W) rear: Michelin Pilot Road K, 180/55 ZR17 M/C (73W)

Front wheel

Front wheel design	Cast aluminum, MT H2
Front-wheel rim size	3.50" x 17"
Front tire designation	120/70 ZR 17

Rear wheel

Battery manufacturer and designation	ETX 14 BS
Rear-wheel rim size	5.5" x 17"
Rear tire designation	180/55 ZR 17

Tire inflation pressure

Tire pressure, front	36.3 psi (2.5 bar), Single rider, with cold tire 36.3 psi (2.5 bar), Driver with passenger and/or load, with cold tire
Tire pressure, rear	40.6 psi (2.8 bar), Single rider, with cold tire 40.6 psi (2.8 bar), Driver with passenger and/or load, with cold tire

Electrical system

Electrical rating of onboard socket	5 A, an onboard socket
Fuses	All electrical circuits are electronically protected. If an electronic fuse trips and de-energizes a circuit, the circuit is active as soon as the ignition is switched on after the fault has been rectified.

Battery

Battery manufacturer and designation	ETX 14 BS
Battery design	AGM (Absorptive Glass Matt) battery
Battery voltage	12 V
Battery capacity	14 Ah

Spark plugs

Spark plugs, manufacturer and designation	NGK DCPR 8 E
Electrode gap of spark plug	0.04 \pm 0 in (0.9 \pm 0 mm), New
	max 0.05 in (max 1.2 mm), Wear limit

Bulbs

Bulb for high-beam headlight	H7 / 12 V / 55 W
Bulb for low-beam headlight	H7 / 12 V / 55 W
Bulb for parking light	W5W / 12 V / 5 W
Bulb for taillight/brake light	P21/5W / 12 V / 5 W / 21 W
Bulbs for flashing turn indicators, front	R10W / 12 V / 10 W
with OE White turn indicators:	RY10W / 12 V / 10 W
Bulbs for flashing turn indicators, rear	R10W / 12 V / 10 W
with OE White turn indicators:	RY10W / 12 V / 10 W

Frame

Frame design	Aluminum delta-box frame
Location of type plate	Right steering head
Location of vehicle identification number	Right steering head

Dimensions

Motorcycle length	82 in (2082 mm)
Motorcycle height	45.5 in (1155 mm), Without driver at unladen weight, up to upper edge of windshield
Motorcycle width	33.9 in (860 mm), Across mirrors
Driver's seat height	32.3 in (820 mm), Without driver at unladen weight
with OE Low dual seat:	31.1 in (790 mm), Without driver at unladen weight
with OE Lowered suspension:	31.1 in (790 mm), Without driver at unladen weight
with OE Lowered suspension and with OE Low dual seat:	29.9 in (760 mm), Without driver at unladen weight

Weights

Unladen weight	450 lbs (204 kg), DIN unladen weight, ready for road, 90 % full tank of gas, without OE
Permissible gross weight	893 lbs (405 kg)
Maximum payload	443 lbs (201 kg)

Riding specifications

Top speed	>124 mph (>200 km/h)
with OE Power reduction:	96 mph (155 km/h)

Service

BMW Motorrad Service	134
BMW Motorrad Service Quality	134
BMW Motorrad Service Card - On- the-spot breakdown assistance	134
BMW Motorrad Service Network	135
Maintenance work	135
Confirmation of maintenance work	136
Confirmation of service	141

BMW Motorrad Service

Advanced technology requires specially adapted methods of maintenance and repair.



If this maintenance and repair work is performed inexpertly, there is a danger of damage and associated safety risks. BMW Motorrad recommends having corresponding work on your motorcycle carried out by a specialized workshop, preferably by an authorized BMW Motorrad retailer. ◀

You can obtain information on the contents of the BMW Services from your BMW Motorrad retailer.

Have all maintenance and repair work carried out confirmed in the "Service" chapter in this manual. Your authorized BMW Motorrad retailer is supplied with all the latest technical information and therefore possesses the neces-

sary technical know-how. BMW Motorrad recommends that you refer any questions about your motorcycle to your authorized BMW Motorrad retailer.

BMW Motorrad Service Quality

BMW Motorrad means not only quality workmanship and high reliability, but also an outstanding quality of service.

To ensure that your BMW is always in optimum condition, BMW Motorrad recommends that you adhere to the regular maintenance schedule for your motorcycle, preferably having the work done by your authorized BMW Motorrad retailer. For generous treatment of claims submitted after the warranty period has expired, evidence of regular maintenance is essential.

Certain signs of wear, moreover, may otherwise not be noticed

until it is too late to correct them at moderate cost. The workshop personnel at BMW Motorrad retailers have thorough knowledge of your motorcycle and can take action before minor problems can turn into major trouble. By having the necessary repairs done properly and in good time, you save time and money in the long run.

BMW Motorrad Service Card - On-the-spot breakdown assistance

With all new BMW motorcycles, the BMW Motorrad Service Card protects you in the event of a breakdown with an extensive range of services such as breakdown assistance, motorcycle transportation etc. (differing regulations are possible in individual countries). In the case of a breakdown, contact the Mobile Service of BMW Motorrad. Here you will find our specialists ready

to help with both advice and action.

Important country-specific contact addresses and the relevant after-sales service organization phone numbers as well as information on Mobile Service and the retail network can be found in the "Service Kontakt/Service Contact" brochures.

BMW Motorrad Service Network

With its worldwide service network, BMW Motorrad can attend to you and your motorcycle in over 100 countries around the globe. In Germany alone, there are approximately 200 authorized BMW Motorrad retailers ready to assist you.

All information concerning the international dealership network can be found in the brochure "Service Contact Europe" or

"Service Contact Africa, America, Asia, Australia, Oceania".

Maintenance work

BMW Pre-Delivery Check

The BMW pre-delivery check is carried out by your authorized BMW Motorrad retailer before it turns over the motorcycle to you.

BMW Running-in Check

The BMW running-in check has to be performed when the motorcycle has covered between 300 miles (500 km) and 750 miles (1,200 km).

BMW Service

BMW Service is carried out once a year. The scope of the services performed may be dependent on the vehicle owner and the mileage driven. Your BMW Motorrad retailer confirms that the service has been performed

and enters the date for the next service.

For drivers who drive long distances annually, it may be necessary to come in for service before the entered date. In this case a corresponding maximum odometer reading will also be entered in the confirmation of service. If this odometer reading is reached before the next service date, service must be performed sooner.

The service display in the multi-function display reminds you of the next service date approx. one month or 600 miles (1,000 km) before the entered values.

Confirmation of maintenance work

BMW Pre-Delivery Check

Conducted

on _____

Stamp, Signature

BMW Running-in Check

Conducted

on _____

Odometer reading _____

Next service
at the latest

on _____

or, if reached sooner,

Odometer reading _____

Stamp, Signature

BMW Service

Conducted

on _____

Odometer reading _____

Next service
at the latest

on _____

or, if reached sooner,

Odometer reading _____

Stamp, Signature**BMW Service**

Conducted

on _____

Odometer reading _____

Next service
at the latest

on _____

or, if reached sooner,

Odometer reading _____

Stamp, Signature**BMW Service**

Conducted

on _____

Odometer reading _____

Next service
at the latest

on _____

or, if reached sooner,

Odometer reading _____

Stamp, Signature

BMW Service

Conducted

on _____

Odometer reading _____

Next service
at the latest

on _____

or, if reached sooner,

Odometer reading _____

Stamp, Signature**BMW Service**

Conducted

on _____

Odometer reading _____

Next service
at the latest

on _____

or, if reached sooner,

Odometer reading _____

Stamp, Signature**BMW Service**

Conducted

on _____

Odometer reading _____

Next service
at the latest

on _____

or, if reached sooner,

Odometer reading _____

Stamp, Signature

BMW Service

Conducted

on _____

Odometer reading _____

Next service

at the latest

on _____

or, if reached sooner,

Odometer reading _____

Stamp, Signature**BMW Service**

Conducted

on _____

Odometer reading _____

Next service

at the latest

on _____

or, if reached sooner,

Odometer reading _____

Stamp, Signature**BMW Service**

Conducted

on _____

Odometer reading _____

Next service

at the latest

on _____

or, if reached sooner,

Odometer reading _____

Stamp, Signature

BMW Service

Conducted

on _____

Odometer reading _____

Next service
at the latest

on _____

or, if reached sooner,

Odometer reading _____

Stamp, Signature**BMW Service**

Conducted

on _____

Odometer reading _____

Next service
at the latest

on _____

or, if reached sooner,

Odometer reading _____

Stamp, Signature**BMW Service**

Conducted

on _____

Odometer reading _____

Next service
at the latest

on _____

or, if reached sooner,

Odometer reading _____

Stamp, Signature

Confirmation of service

The table is intended as proof of maintenance, warranty and repair work, the installed optional accessories and any special campaign (recall) work carried out.

Work carried out	Odometer reading	Date

A

- Abbreviations and symbols, 6
- ABS
 - Self-diagnosis, 64
- Accessories
 - General instructions, 76
- Anti-theft alarm, 18

B

- Battery, 15
 - Charging connected battery, 112
 - Charging disconnected battery, 112
 - Installing, 113
 - Installing compartment cover, 113
 - Maintenance instructions, 111
 - Removing, 113
 - Removing compartment cover, 113
 - Technical data, 129
- Brake fluid
 - Checking front level, 91
 - Checking rear level, 92

Brake pads

- Check front, 89
- Check rear, 90
- Running in, 65

Brakes

- Adjusting handbrake lever, 51
- Checking operation, 88
- Front fluid tank, 13
- Rear fluid reservoir, 13
- Safety instructions, 65
- Technical data, 126

C

- Care, 115
- Case
 - Adapting, 81
 - Adjusting, 79
 - Closing, 79
 - Mounting, 80
 - Opening, 79
 - Removing, 80
- Checklist, 61
- Cleaning, 115
- Clock, 22
 - Adjusting, 18, 40

Clutch

- Adjusting clutch lever, 51
- Checking operation, 94
- Technical data, 124
- Commissioning, 118
- Confirmation of maintenance work, 136
- Coolant
 - Check level, 93
 - Display, 13
 - Temperature display, 22
 - Topping up, 93
- Currentness of this manual, 7

D

- Damping, 13, 53
- Dimensions
 - Technical data, 131

E

- Electrical system
 - Technical data, 129
- Emergency ON/OFF switch, 17, 50

Engine

- Starting, 62

- Technical data, 122

- Warning for engine electronics, 27

Engine oil

- Check level, 87

- Dipstick, 11

- Fill location, 11

- Temperature display, 24

- Topping up, 88

- Warning for engine oil pressure, 28

Engine speed warning, 45

- Display, 18

Equipment, 6**EWS, 39**

- Warning indicator, 27

F**First-aid kit**

- Location, 14

Flat tire set

- Location, 15

Frame

- Technical data, 130

Front wheel stand, 102**Fuel**

- Quantity indicator, 22, 24

- Refueling, 68

- Technical data, 4

- Warning for fuel down to reserve, 27

Fuses, 129**G**

- Gear indicator, 22, 23

H**Handlebar fittings**

- General view, left, 16

- General view, right, 17

Hazard warning flashers, 16

- Switching off, 49

- Switching on, 48

Headlight

- Adjusting for RHD/LHD traffic, 55

- Headlight range, 55

Headlight flasher, 16**Heated hand grips, 17, 50****Helmet holder, 14, 56****High-beam headlight, 16, 19**

- Indicator light, 22

Horn, 16**I****Idling**

- Indicator light, 22

Ignition

- Switching off, 38

- Switching on, 38

Immobilizer, 39

- Warning indicator, 27

Indicator lights, 18

- Overview, 22

Instrument cluster

- Overview, 18

- Sensor for instrument cluster lighting, 18

J

Jump-starting, 110

K

Keys, 38

L

Lamps

General instructions, 104

High-beam headlight, 19

Low-beam headlight, 19

Parking lights, 19

Replacing brake light and tail light bulbs, 108

Replacing front turn indicator bulb, 109

Replacing high-beam bulb, 104

Replacing low-beam bulb, 104

Replacing parking-light bulb, 106

Replacing rear turn indicator bulb, 109

Technical data, 130

Warning for bulb failure, 28

Lights

Adjusting headlight range, 11

Headlight flasher, 47

High-beam headlight, 47

Low-beam headlight, 47

Parking light, 47

Parking lights, 46

Low-beam headlight, 19

Luggage

Correct loading, 77

Lashing down, 78

M

Maintenance

General instructions, 86

Mirrors

Adjusting, 52

Motorcycle

Care, 115

Cleaning, 115

General view of left side, 11

General view of right side, 13

Returning to use, 118

Storing, 118

Switching off, 66

Multifunction display, 18

O

Odometer and tripmeters

Display range, 22

Resetting, 41

Selecting readings, 40

Onboard computer, 16

Ambient temperature, 42

Average consumption, 42

Average speed, 42

Range, 43

Resetting average consumption, 43

Resetting average speed, 42

Selecting readings, 41

Stopwatch, 44, 45

Onboard socket, 13, 76

Overview of warning indicators, 26, 31, 33

P

Parking lights, 19

Pre-ride check, 63

R

- Rear-wheel drive
 - Technical data, 125
- Rear-wheel stand, 103
- Refueling, 68
- Reserve
 - Warning indicator, 27
- Rider's Manual (US Model), 14
- Running gear
 - Technical data, 125
- Running in, 64

S

- Safety instructions, 60
 - Brakes, 65
- Seat, 14
 - Installing, 56
 - Removing, 56
- Seat lock, 11
- Service, 134
 - Shown in display, 22
- Service Card, 134
- Side stand
 - During starting, 62

- Spark plugs
 - Technical data, 129
- Speedometer, 18
- Spring preload
 - Adjusting, 13, 52
 - Adjustment key, 14
- Starter, 17
- Starting, 62
- Steering lock, 39
- Stopwatch, 18, 22, 44, 45
- Storing, 118
- Switching off, 66

T

- Tachometer, 18
- Technical data
 - Battery, 129
 - Brakes, 126
 - Bulbs, 130
 - Clutch, 124
 - Dimensions, 131
 - Electrical system, 129
 - Engine, 122
 - Frame, 130
 - Fuel, 4

- Rear-wheel drive, 125
- Running gear, 125
- Spark plugs, 129
- Standards, 7
- Transmission, 124
- Weights, 132
- Wheels and tires, 126
- Tire Pressure Control TPC
 - Status indicators, 46
 - Sticker on wheel rim, 96
 - Warning indicators, 32
- Tires
 - Approved tires, 95
 - Checking inflation pressure, 54
 - Checking tread depth, 95
 - Running in, 65
 - Technical data, 126
- Toolkit, 14
 - Service set, 86
- Topcase
 - Closing, 81
 - Mounting, 82
 - Opening, 81
 - Removing, 82
- Torques, 121

- Transmission
 - During starting, 62
 - Technical data, 124
- Troubleshooting chart, 120
- Turn indicators
 - Indicator light, 22
 - Left, 16, 47
 - Right, 17, 48
 - Switching off, 17, 48

W

- Warning indicators
 - Display, 24
- Warning lamps, 18
- Warning symbols
 - Display range, 22
- Weights
 - Technical data, 132
- Wheels
 - Installing front wheel, 97
 - Installing rear wheel, 100
 - Removing front wheel, 96
 - Removing rear wheel, 99
 - Technical data, 126

Reporting Safety Defects

If you believe that your vehicle has a defect which could cause a crash or could cause injury or death, you should immediately inform the National Highway Traffic Safety Administration (NHTSA) in addition to notifying BMW of North America, LLC.

If NHTSA receives similar complaints, it may open an investigation, and if it finds that a safety defect exists in a group of vehicles, it may order a recall and remedy campaign. However, NHTSA cannot become involved in individual problems between you, your dealer, or BMW of North America, LLC.

To contact NHTSA, you may call the Vehicle Safety Hotline toll-free at 1-888-327-4236 (TTY: 1-800-424-9153); go to <http://www.safercar.gov>; or write to:
Administrator, NHTSA,
400 Seventh Street, SW.,
Washington, DC 20590.
You can also obtain other information about motor vehicle safety from <http://www.safercar.gov>.

Details described or illustrated in this booklet may differ from the motorcycle's actual specification as purchased, the accessories fitted or the national-market specification. No claims will be entertained as a result of such discrepancies.

Dimensions, weights, fuel consumption and performance data are quoted to the customary tolerances.

The right to modify designs, equipment and accessories is reserved.

Errors and omissions excepted.

© 2007 BMW Motorrad

Not to be reproduced either wholly or in part without written permission from BMW Motorrad, After Sales.

Printed in Germany.

Important data for refueling

Fuel	
Recommended fuel quality	95 ROZ/RON, Super unleaded
with OE Regular unleaded (RON 91):	91 ROZ/RON, Regular unleaded (fuel type can be used with reduced performance and consumption)
Usable fuel quantity	4.2 gal (16 l)
Reserve fuel quantity	≥1.1 gal (≥4 l)
Tire inflation pressure	
Tire pressure, front	36.3 psi (2.5 bar), Single rider, with cold tire 36.3 psi (2.5 bar), Driver with passenger and/or load, with cold tire
Tire pressure, rear	40.6 psi (2.8 bar), Single rider, with cold tire 40.6 psi (2.8 bar), Driver with passenger and/or load, with cold tire

BMW recommends 

Order No.: 01 47 7 709 227
06.2007, 3rd Edition



F 800 S / F 800 ST

D	Korrektur zu F 800 S und F 800 ST (Seite 77)
	Tempolimit für Fahrten mit Koffer: siehe Hinweisschild im Koffer.
GB	Correction for F 800 S and F 800 ST (Page 77)
	Maximum permissible speed for riding with cases: See label inside the case.
F	Correction concernant F 800 S et F 800 ST (Page 79)
	Limitation de vitesse pour conduites avec valises : voir plaquette d'avertissement dans la valise.
E	Modificación para F 800 S y F 800 ST (Página 83)
	Límite de velocidad con maleta montada: véase placa de advertencia de la maleta.
I	Correzione per F 800 S e F 800 ST (Pagina 77)
	Limite di velocità per la marcia con valigia: vedere la targhetta di avvertenza nella valigia.
S	Korrigerig för F 800 S och F 800 ST (Sidan 75)
	Hastighetsgräns för körning med toppbox: se anvisningsskylt i toppboxen.
NL	Correctie voor F 800 S en F 800 ST (Pagina 77)
	Snelheidslimiet voor het rijden met koffer: Zie de sticker in de koffer.

USA	Correction for F 800 S and F 800 ST (Page 77)
	Speed limit when riding with case: see label in case.
P	Correcção referente à F 800 S e F 800 ST (Página 78)
	Limite de velocidade para viagens com mala: consultar etiqueta de informação na mala.
FIN	Korjaus käsikirjoihin F 800 S ja F 800 ST (Sivu 78)
	Nopeusrajoitus laukut asennettuina: ks. huomautuskilpi laukussa.
GR	Διόρθωση για F 800 S και F 800 ST (Σελίδα 77)
	Όριο ταχύτητας για οδήγηση με βαλίτσες: βλέπε πινακίδα οδηγιών στη βαλίτσα.
J	改訂 : F 800 S および F 800 ST (ページ 77)
	ケースを装着している場合の最高速度 : ケース内の注意ステッカーを参照
PL	Korekta do F 800 S i F 800 ST (Strona 79)
	Ograniczenie prędkości dla jazdy z kufrem: patrz tabliczka informacyjna w kufrze.

