

# Rider's Manual

## R 1200 S



BMW Motorrad



The Ultimate Riding  
Machine

## Motorcycle data/dealership details

### Motorcycle data

---

Model

---

Vehicle identification number

---

Colour code

---

Date of first registration

---

Registration number

### Dealership details

---

Person to contact in Service department

---

Ms/Mr

---

Phone number

---

Dealership address/phone number  
(company stamp)

## **Welcome to BMW**

We congratulate you on your choice of a motorcycle from BMW and welcome you to the community of BMW riders. Familiarise yourself with your new motorcycle so that you can ride it safely and confidently in all traffic situations. Please read this Rider's Manual carefully before starting to use your new BMW motorcycle. It contains important information on how to operate the controls and how to make the best possible use of all your BMW's technical features. In addition, it contains information on maintenance and care to help you maintain your motorcycle's reliability and safety, as well as its value. If you have questions concerning your motorcycle, your

authorised BMW Motorrad dealer will gladly provide advice and assistance.

We hope that you will enjoy riding your BMW and that all your journeys will be pleasant and safe.

BMW Motorrad.

## Table of Contents

You can also consult the index at the end of this Rider's Manual if you want to find a particular topic or item of information.

<b>1 General instructions ...</b>	<b>5</b>	<b>3 Status indicators .....</b>	<b>19</b>	Lights .....	40
Overview .....	6	Multifunction display .....	20	Headlight .....	41
Abbreviations and symbols .....	6	Warning and telltale lights .....	20	Turn indicators .....	42
Equipment .....	7	ABS warning light <sup>OE</sup> .....	20	Front and rear seats .....	44
Technical data .....	7	Function indicators .....	20	Helmet holder .....	45
Currency .....	7	Warnings, general .....	21	Mirrors .....	46
<b>2 General views .....</b>	<b>9</b>	ABS warning indicators <sup>OE</sup> .....	27	ABS <sup>OE</sup> .....	46
General view, left side ...	11	<b>4 Operation .....</b>	<b>31</b>	Suspension settings .....	47
General view, right side .....	13	Ignition switch and steering lock .....	32	Settings, standard suspension .....	47
Underneath the seat .....	14	Electronic immobiliser (EWS) .....	33	Settings, sport suspension <sup>OE</sup> .....	49
Handlebar fitting, left .....	15	Hazard warning flashers .....	34	Tyres .....	53
Handlebar fitting, right ...	16	Tripmaster .....	35	<b>5 Riding .....</b>	<b>55</b>
Instrument cluster .....	17	Clock .....	37	Safety instructions .....	56
Headlight .....	18	Emergency off switch (kill switch) .....	38	Checklist .....	58
		Grip heating <sup>OE</sup> .....	39	Starting .....	58
		Clutch .....	39	Running in .....	60
		Brakes .....	40	Parking your motorcycle .....	61
				Refuelling .....	62
				Brake system, general ...	63

Brake system with BMW Motorrad ABS <sup>OE</sup> .....	64				
<b>6 Accessories .....</b>	<b>69</b>				
General instructions .....	70				
Power socket .....	70				
<b>7 Maintenance .....</b>	<b>73</b>				
General instructions .....	74				
Toolkit .....	74				
Additional toolkit for sport suspension (OE) .....	74				
Engine oil .....	74				
Brake system, general ...	76				
Brake pads .....	77				
Brake fluid .....	78				
Clutch .....	80				
Tyres .....	81				
Rims .....	81				
Wheels .....	81				
Front-wheel stand .....	87				
Rear wheel stand .....	88				
Bulbs .....	89				
Jump start .....	96				
Battery .....	97				
		<b>8 Care .....</b>	<b>101</b>		
		Care products .....	102		
		Washing motorcycle ....	102		
		Cleaning easily damaged components .....	103		
		Paint care .....	104		
		Protective wax coating .....	104		
		Laying up motorcycle ...	104		
		Restoring motorcycle to use .....	105		
		<b>9 Technical data .....</b>	<b>107</b>		
		Troubleshooting chart .....	108		
		Threaded fasteners .....	109		
		Engine .....	110		
		Riding specifications ...	112		
		Clutch .....	112		
		Transmission .....	112		
		Final drive .....	113		
		Running gear .....	113		
		Brakes .....	115		
		Wheels and tyres .....	115		
		Electrics .....	116		
		Frame .....	118		
		Dimensions .....	118		
		Weights .....	119		
		<b>10 Service .....</b>	<b>121</b>		
		BMW Motorrad service .....	122		
		BMW Motorrad service quality .....	122		
		BMW Motorrad Service Card: on-the-spot breakdown assistance .....	123		
		BMW Motorrad service network .....	123		
		Maintenance work .....	123		
		Maintenance schedules .....	124		
		Confirmation of maintenance work .....	125		
		Confirmation of service .....	130		



## **General instructions**

Overview .....	6
Abbreviations and symbols .....	6
Equipment .....	7
Technical data .....	7
Currency .....	7

## Overview

Chapter 2 of this Rider's Manual will provide you with an initial overview of your motorcycle. All maintenance and servicing work on the motorcycle is documented in Chapter 10. This record of the maintenance work you have had performed on your motorcycle is a precondition for generous treatment of goodwill claims.

When the time comes to sell your BMW, please remember to hand over this Rider's Manual; it is an important part of the motorcycle.

## Abbreviations and symbols

 Indicates warnings that you must comply with for reasons of your safety and the safety of others, and to pro-

tect your motorcycle against damage.

 Specific instructions on how to operate, control, adjust or look after items of equipment on the motorcycle.

◀ Indicates the end of an item of information.

• Instruction.

» Result of an activity.

 Reference to a page with more detailed information.

◁ Indicates the end of a passage relating to specific accessories or items of equipment.

 Tightening torque.



Item of technical data.

OE Optional extra  
Your motorcycle was assembled complete with all the BMW optional extras you ordered.

OA Optional accessory  
You can obtain optional accessories through your authorised BMW Motorrad dealer; optional accessories have to be retrofitted to the motorcycle.

EWS Electronic immobiliser (Elektronische Wegfahrsicherung).

ABS Anti-lock brake system

DWA Anti-theft alarm (Diebstahlwarnanlage)



## Equipment

When you ordered your BMW motorcycle, you chose various items of custom equipment. This Rider's Manual describes optional extras (OE) offered by BMW and selected optional accessories (OA). This explains why the manual may also contain descriptions of equipment which you have not ordered. Please note, too, that your motorcycle might not be exactly as illustrated in this manual on account of country-specific differences. If your BMW was supplied with equipment not described in this Rider's Manual, you will find these features described in separate manuals.

## Technical data

All dimensions, weights and power ratings stated in the Rider's Manual are quoted to the standards and comply with the tolerance requirements of the Deutsche Institut für Normung e.V. Versions for individual countries may differ.

## Currency

The high safety and quality standards of BMW motorcycles are maintained by constant development work on designs, equipment and accessories. Because of this, your motorcycle may differ from the information supplied in the Rider's Manual. Nor can BMW Motorrad entirely rule out errors and omissions. We hope you will appreciate that no claims can be entertained on the basis of the

data, illustrations or descriptions in this manual.



## General views

General view, left side .....	11
General view, right side .....	13
Underneath the seat .....	14
Handlebar fitting, left .....	15
Handlebar fitting, right .....	16
Instrument cluster .....	17
Headlight .....	18

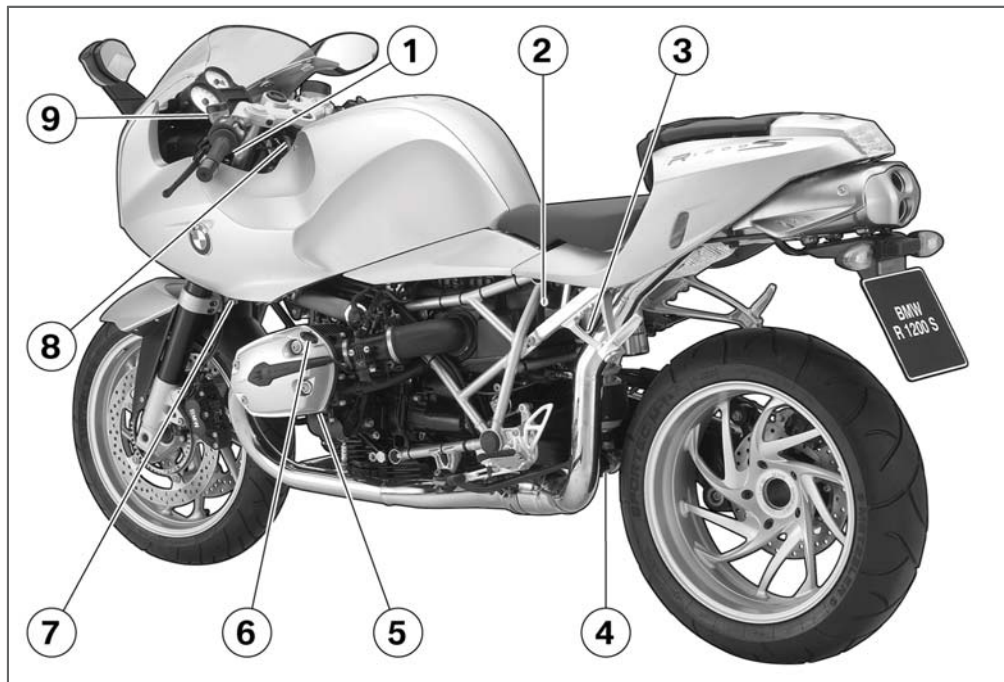

## General view, left side

- 1 Adjuster for headlight beam throw underneath the instrument cluster (⇒ 42)
- 2 Seat lock (⇒ 44)
- 3 Adjuster, spring preload, rear (⇒ 47)
- 4 Adjuster, damping, rear, standard suspension (⇒ 47)
- 5 Oil sight glass (⇒ 74)
- 6 Filler neck, engine oil (⇒ 76)
- 7 Adjuster, damping, front, sport suspension (OE) (⇒ 47)
- 8 Adjuster, spring preload, front, sport suspension (OE) (⇒ 47)
- 9 Clutch-fluid reservoir (⇒ 80)

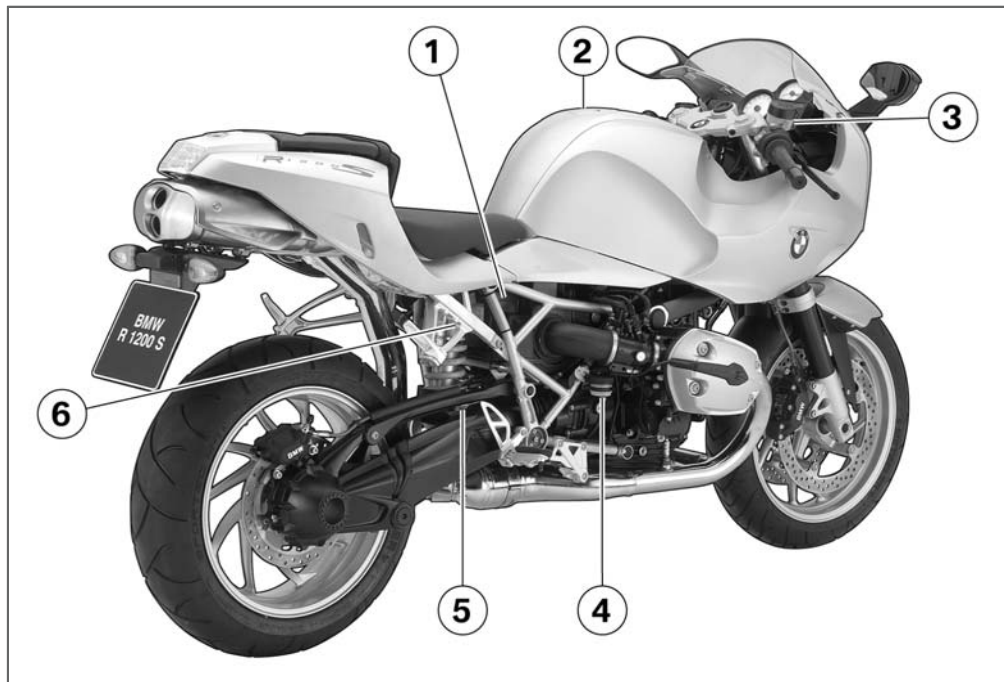

## General view, right side

- 1 Power socket (➡ 70)
- 2 Filler neck, fuel (➡ 62)
- 3 Brake-fluid reservoir, front (➡ 78)
- 4 Brake-fluid reservoir, rear (➡ 79)
- 5 Adjuster, rebound-stage damping, rear, sport suspension (OE) (➡ 47)
- 6 Adjuster, compression-stage damping, rear, sport suspension (OE) (➡ 47)

## Underneath the seat

- 1 Hook wrench
- 2 Release, rear seat  
(→ 44)
- 3 Table of tyre pressures
- 4 Toolkit (→ 99)
- 5 Battery (→ 99)

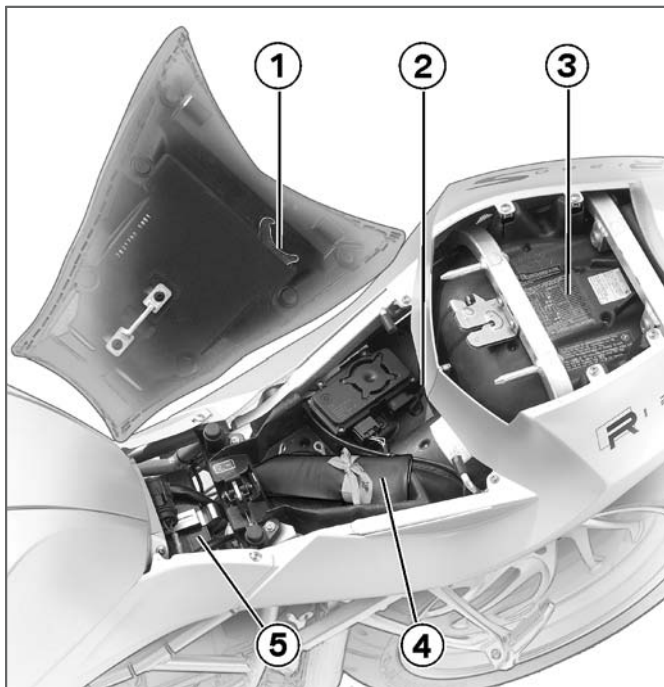



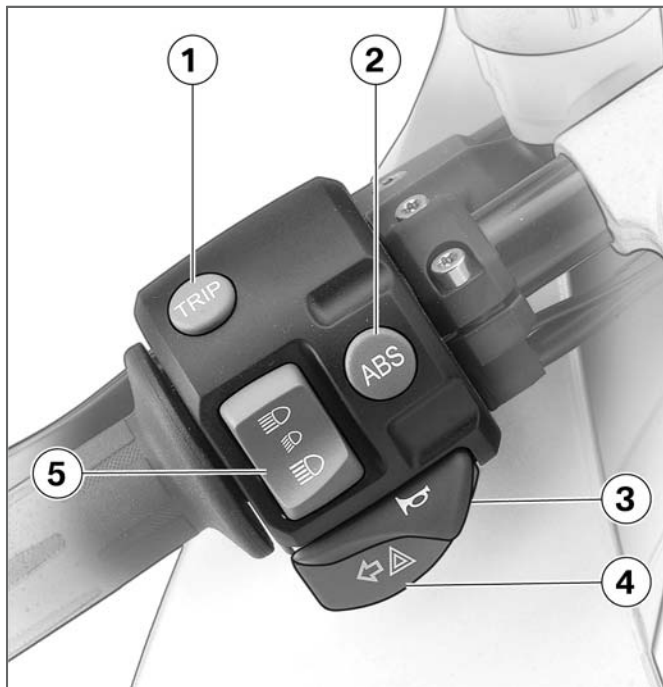

## Handlebar fitting, left

- 1 Button for Tripmaster (➡ 35)
- 2 Pushbutton, ABS (OE) (➡ 46)
- 3 Pushbutton, horn
- 4 Pushbutton, left flashing turn indicators and hazard warning flashers (➡ 42) (➡ 34)
- 5 Switch, high-beam headlight and headlight flasher (➡ 41)

## Handlebar fitting, right

- 1 Emergency off switch (kill switch) (➔ 38)
- 2 Pushbutton, starter (➔ 58)
- 3 With OE Heated handlebar grips:  
Grip heating (➔ 39)
- 4 Pushbutton, right flashing turn indicators and hazard warning flashers (➔ 43) (➔ 34)
- 5 Pushbutton, cancel flashing turn indicators and hazard warning flashers (➔ 43) (➔ 35)



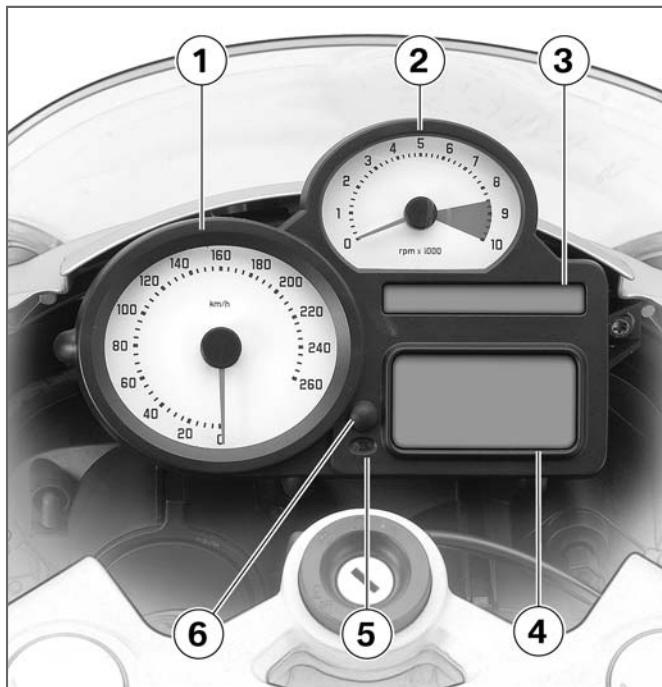

## Instrument cluster

- 1 Speedometer
- 2 Rev. counter
- 3 Warning and telltale lights (➡ 21)
- 4 Multifunction display (➡ 21)
- 5 Telltale light for anti-theft alarm (OE) and sensor for instrument cluster lighting
- 6 Button for setting clock and operating Tripmaster (➡ 37) (➡ 35)

▶ The instrument-cluster lighting has automatic day and night switchover. ◀

## Headlight

- 1 Low-beam headlight
- 2 High-beam headlight
- 3 Parking light

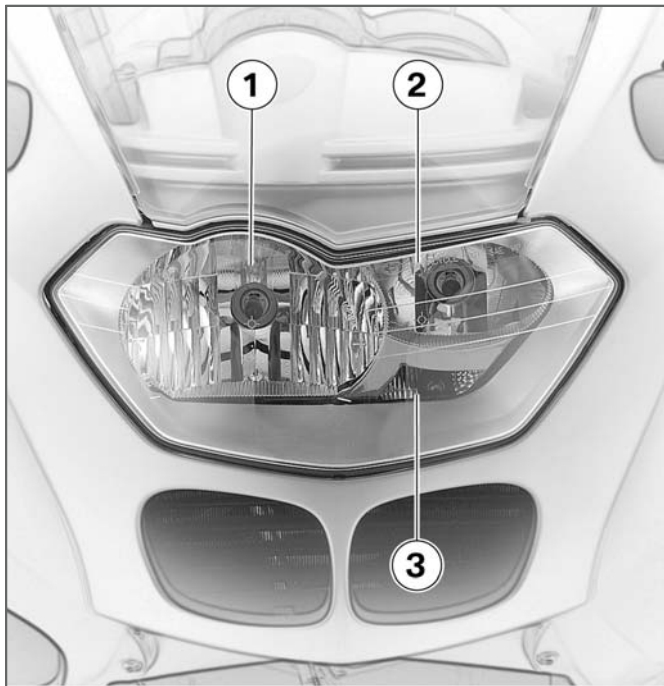

## Status indicators

Multifunction display .....	20
Warning and telltale lights .....	20
ABS warning light <sup>OE</sup> .....	20
Function indicators .....	20
Warnings, general .....	21
ABS warning indicators <sup>OE</sup> .....	27

## Multifunction display

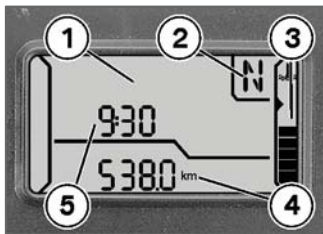

- 1 Panel for warnings (⇒ 21)
- 2 Gear indicator (⇒ 20)
- 3 Engine-oil temperature display (⇒ 20)
- 4 Tripmaster display (⇒ 35)
- 5 Clock (⇒ 37)

## Warning and telltale lights

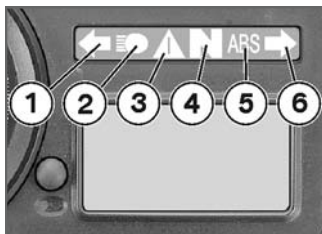

- 1 Telltale light, left turn indicator
- 2 Telltale light, high-beam headlight
- 3 Warning light, general
- 4 Telltale light, neutral
- 5 Warning light, ABS (OE)
- 6 Telltale light, right turn indicator

## ABS warning light<sup>OE</sup>

The way in which the ABS warning light indicates status can differ in some countries.



Alternative for the ABS warning light.

## Function indicators

### Gear



Shows which gear is engaged.

If no gear is engaged, the gear indicator shows N and the 'neutral' telltale light also lights up.

### Engine-oil temperature



The horizontal bars below the temperature symbol indicate the engine-oil temperature.

## **Warnings, general**











### **Mode of presentation**

General warnings are displayed by means of plain-text messages and symbols in the multifunction display. In some cases, they are accompanied by the 'General' warning light showing red or yellow. Two or more warnings can be issued at the same time.

## Warnings, overview

### Mode of presentation

### Meaning

	Shows yellow		The <b>EWS!</b> warning appears on the display.	Electronic immobiliser active (➡ 24)
	Shows yellow		The <b>FUEL!</b> warning appears on the display.	Fuel down to reserve (➡ 24)
	Shows yellow		Appears on the display	Engine electronics (➡ 24)
	Flashes red four times per second		Appears on the display	Insufficient engine oil pressure (➡ 25)
	Shows red		Appears on the display	Insufficient battery charge current (➡ 25)
	Shows yellow		The <b>LAMP R!</b> warning appears on the display.	Rear light bulb defective (➡ 26)
			The <b>LAMP F!</b> warning appears on the display.	Front light bulb defective (➡ 26)
	Shows yellow		The <b>LAMP S!</b> warning appears on the display.	Bulbs defective (➡ 26)



## Mode of presentation

## Meaning

	The DWA ! warning appears on the display.	Anti-theft alarm battery weak (➡ 27)
 Shows yellow	The DWA ! warning appears on the display.	Anti-theft alarm battery flat (➡ 27)

### Electronic immobiliser active



General warning light shows yellow.

The EWS ! warning appears on the display.

The key being used is not authorised for starting, or communication between key and engine electronics is disrupted.

- Remove all other vehicle keys from the same ring as the ignition key.
- Use the reserve key.
- Have the defective key replaced, preferably by an authorised BMW Motorrad dealer.

### Fuel down to reserve



General warning light shows yellow.

The FUEL ! warning appears on the display.



Lack of fuel can result in the engine misfiring and cutting out unexpectedly. Misfiring can damage the catalytic converter; a hazardous situation can result if the engine cuts out unexpectedly. Do not run the fuel tank dry. ◀



The Tripmaster calculates the residual operating range and shows this estimated figure on the display. ◀

The fuel tank contains no more than the reserve quantity of fuel.



Fuel capacity, reserve

4 l

- Refuelling (➡ 62)

### Engine electronics



General warning light shows yellow.



Engine electronics symbol appears on the display.



The engine is running in emergency operating mode. Engine power might be reduced and this can cause hazardous situations, particularly if you attempt to overtake other road users. Engine power level might be lower than normal: adapt your style of riding accordingly. ◀

The engine electronics control unit has diagnosed a fault. In exceptional cases, the engine stops and refuses to start. Otherwise, the engine runs in emergency operating mode.

- You can continue to ride, but bear in mind that the usual engine power might not be available.
- Have the fault rectified as quickly as possible by a

specialist workshop, preferably an authorised BMW Motorrad dealer.

### Insufficient engine oil pressure



General warning light flashes red four times per second.



Engine oil pressure symbol appears on the display.

The oil pressure in the lube-oil system is too low.



The insufficient oil pressure warning does not fulfil the function of an oil gauge. The only way of checking whether the oil level is correct is to check the oil sight glass.◀

A low oil level is one reason why a warning indicating insufficient oil pressure is issued.

- Checking engine oil level (➡ 74)

If the oil level is too low:

- Topping up the engine oil (➡ 76)

If the warning indicating insufficient engine oil level is issued and a check indicates that the engine oil level is correct:



Other engine problems besides a low oil level can cause the insufficient engine oil pressure warning to be issued. Continuing to ride in these cases can cause engine damage.

If this warning is issued even though the engine oil level is correct: do not continue to ride.◀

- Do not continue your journey.
- Have the fault rectified as quickly as possible by a

specialist workshop, preferably an authorised BMW Motorrad dealer.

### Insufficient battery charge current



General warning light shows red.



Battery charge current symbol is displayed.



A discharged battery can result in the engine cutting out unexpectedly, causing a hazardous situation. Have faults rectified as soon as possible.◀



If the battery is not charging, continuing to ride can cause it to discharge completely, in which case it will suffer irreparable damage. If possible, do not continue your journey.◀

Battery is not being charged.

- You can continue to ride until the battery is discharged. Bear in mind, however, that the engine could cut out suddenly and that the battery could discharge until completely flat, in which case it might have suffered irreparable damage.
- Have the fault rectified as quickly as possible by a specialist workshop, preferably an authorised BMW Motorrad dealer.

### Rear light bulb defective



General warning light shows yellow.

The LAMPR ! warning appears on the display.



A defective bulb places your safety at risk because it is easier for other

users to oversee you and your motorcycle.

Replace defective bulbs as soon as possible; always carry a complete set of spare bulbs if possible. ◀

Rear light or brake light bulb defective.

- Have the fault rectified by a specialist workshop, preferably an authorised BMW Motorrad dealer.

### Front light bulb defective

The LAMPF ! warning appears on the display.



A defective bulb places your safety at risk because it is easier for other users to oversee you and your motorcycle.

Replace defective bulbs as soon as possible; always carry a complete set of spare bulbs if possible. ◀

Low-beam headlight, high-beam headlight, side-light or turn-indicator bulb defective.

- Replacing high-beam/low-beam headlight bulb (⇒ 90)
- Replacing parking-light bulb (⇒ 92)
- Replacing front turn indicator bulb (⇒ 94)
- Replacing rear turn indicator bulb (⇒ 95)

### Bulbs defective



General warning light shows yellow.

The LAMPS ! warning appears on the display.



A defective bulb places your safety at risk because it is easier for other users to oversee you and your motorcycle.

Replace defective bulbs as soon as possible; always

carry a complete set of spare bulbs if possible. ◀

A combination of the bulb defects described above has occurred.

- See the fault descriptions above.

### **Anti-theft alarm battery weak**

The DWA ! warning appears on the display.

The integral battery in the anti-theft alarm has lost a significant proportion of its original capacity. There is no assurance of how long the anti-theft alarm can remain operational if the motorcycle's battery is disconnected.

- Seek the advice of a specialist workshop, preferably an authorised BMW Motorrad dealer.

### **Anti-theft alarm battery flat**



General warning light shows yellow.

The DWA ! warning appears on the display.

The integral battery in the anti-theft alarm has lost its entire original capacity. There is no assurance that the anti-theft alarm will be operational if the motorcycle's battery is disconnected.

- Seek the advice of a specialist workshop, preferably an authorised BMW Motorrad dealer.

## **ABS warning indicators<sup>OE</sup>**

### **Mode of presentation**

ABS warnings are indicated by the ABS warning light. The warning light can show continuously or flash at a rate of one flash per second.

There are two country-dependent versions of the ABS warning light:



Version 1.



Version 2.

Version 1 is used as the basis for the description of the warnings in this section.

**Warnings, overview****Mode of presentation****Meaning**

Flashes once per second

Self-diagnosis not completed  
(⇒ 29)

Lights up

ABS fault (⇒ 29)



Lights up

ABS switched off (⇒ 29)

### Self-diagnosis not completed

 ABS warning light flashes once per second.

The ABS function is not available, because self-diagnosis did not complete. The motorcycle has to move forward a few metres for the wheel sensors to be tested.

- Pull away slowly. Bear in mind that the ABS function is not available until self-diagnosis has completed.

### ABS fault

 ABS warning light ON.

The ABS control unit has detected a fault. The ABS function is not available.

- You can continue to ride. Bear in mind that the ABS function is not available.

Bear in mind the more detailed information on situations that can lead to an ABS fault (➡ 66).

- Have the fault rectified as quickly as possible by a specialist workshop, preferably an authorised BMW Motorrad dealer.

### ABS switched off

 ABS warning light ON.

The rider has switched off the ABS system.

With OE Anti-lock braking system (ABS):

- Activate the ABS function (➡ 46)





## Operation

Ignition switch and steering lock.....	32	Mirrors.....	46
Electronic immobiliser (EWS) ...	33	ABS <sup>OE</sup> .....	46
Hazard warning flashers .....	34	Suspension settings .....	47
Tripmaster .....	35	Settings, standard suspension.....	47
Clock .....	37	Settings, sport suspension <sup>OE</sup> ..	49
Emergency off switch (kill switch).....	38	Tyres .....	53
Grip heating <sup>OE</sup> .....	39		
Clutch .....	39		
Brakes .....	40		
Lights .....	40		
Headlight .....	41		
Turn indicators .....	42		
Front and rear seats .....	44		
Helmet holder .....	45		

## Ignition switch and steering lock

### Keys

You receive one master key and one spare key. Please consult the information on the electronic immobiliser (EWS) if a key is lost or mislaid (➔ 33).

▶ Ignition switch and steering lock, seat lock and tank filler cap lock are all operated with the same key.◀

### Switching on ignition



- Turn the key to position **1**.
  - » Side lights and all function circuits switched on.
  - » Engine can be started.
  - » Pre-ride check is performed. (➔ 59)

With OE Anti-lock braking system (ABS):

- Turn the key to position **1**.
  - » Side lights and all function circuits switched on.
  - » Engine can be started.
  - » Pre-ride check is performed. (➔ 59)

» ABS self-diagnosis is performed. (➔ 60)◀

### Switching off ignition

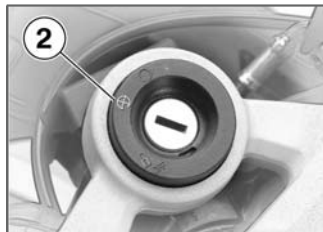

- Turn the key to position **2**.
  - » Lights switched off.
  - » Handlebars not locked.
  - » Key can be removed.
  - » Electrically powered accessories remain operational for a limited period of time.
  - » The battery can be recharged via the on-board socket.

## Locking handlebars

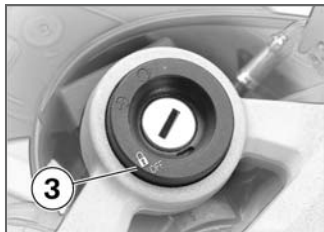

**!** If the motorcycle is on the side stand, the surface of the ground will determine whether it is better to turn the handlebars to the left or right. However, the motorcycle is more stable on a level surface with the handlebars turned to the left than with the handlebars turned to the right.

On level ground, always turn the handlebars to the left to set the steering lock. ◀

- Turn the handlebars to the full left or right lock position.
- Turn the key to position **3**, while moving the handlebars slightly.
  - » Ignition, lights and all function circuits switched off.
  - » Handlebars locked.
  - » Key can be removed.

## Electronic immobiliser (EWS)

### Protection against theft

The electronic immobiliser helps protect your BMW Motorrad motorcycle from theft, and this enhanced security is at your disposal without any need for you to set parameters or activate additional systems. The engine of a motorcycle fitted with this electronic immobiliser can be started only with the keys that belong to the vehicle. You can also

have your authorised BMW Motorrad dealer bar individual keys, for example if a particular key goes missing. The engine cannot be started with a key that has been barred.

### In-key electronics

An electronic component is integrated into each of your keys. The motorcycle's electronics exchange certain continuously changing signals with the electronics in the key; these signals are specific to your motorcycle and they are transmitted via the ring aerial in the ignition lock. The ignition is not enabled for starting until the key has been recognised as "authorised" for your motorcycle.

▶ A spare key attached to the same ring as the ignition key used to start the engine could "irritate" the

electronics, in which case the enabling signal for starting is not issued. The EWS warning appears in the multifunction display.

Always keep the spare key separately from the ignition key. ◀

## Replacement and extra keys

You can obtain replacement/extra keys only through an authorised BMW Motorrad dealer. The keys are part of an integrated security system, so the dealer is under an obligation to check the legitimacy of all applications for replacement/extra keys. If you want to have a lost key barred, you have to bring with you all the other keys that belong to the motorcycle. A key that has been barred can

subsequently be cleared and reactivated for use.

## Hazard warning flashers

### Switching on hazard warning flashers

- Switch on the ignition.

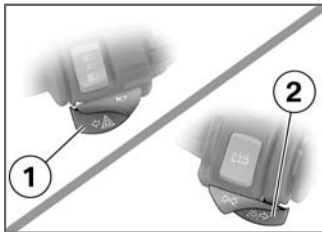

- Simultaneously press button **1** for left turn indicators and button **2** for right turn indicators.

▶ The hazard warning flashers place a strain on the battery. Do not use the hazard warning flashers for longer than absolutely necessary. ◀

▶ If you press a turn-indicator button with the ignition switched on, the turn-indicator function is activated instead of the hazard warning flashers, and remains active until you release the button. The hazard warning flashers recommence flashing as soon as the button is released. ◀

- » Hazard warning flashers in operation.
- » Left/right turn indicator tell-tale lights flash.
- Switch off the ignition.
- » The hazard warning flashers continue to operate.

- » Left/right turn indicator tell-tale lights off.

## Switching off hazard warning flashers

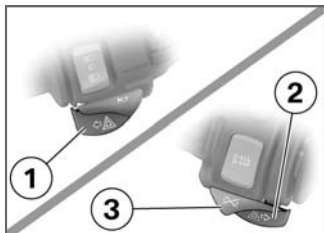

- Press cancel button **3**.
- » Hazard warning flashers switched off.
- Alternative: Simultaneously press button **1** for left turn indicators and button **2** for right turn indicators.
- » Hazard warning flashers switched off.

## Tripmaster

### Operating Tripmaster

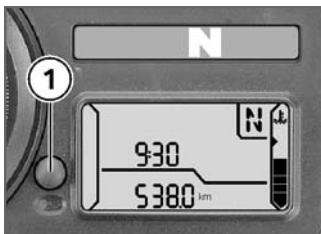

You have the option of using pushbutton **1** in the instrument cluster to operate the Tripmaster as described below.

### Selecting readings

- Switch on the ignition.

▶ When you switch on the ignition, the information shown by the Tripmaster when the ignition was switched off always reappears on the multifunction display.◀



- Briefly press the Tripmaster button **1** once to proceed to each subsequent step in the cycle.

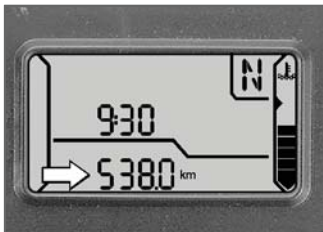

The Tripmaster display field cycles through the following sequence:

- Total distance covered
- Tripmeter 1 (Trip I)
- Tripmeter 2 (Trip II)
- Residual range (once fuel level is down to reserve)

### Resetting tripmeter

- Switch on the ignition.
- Select the desired tripmeter.



- Press and hold down Tripmaster button **1** until the reading changes.
- » The tripmeter is reset to zero.

### Residual range

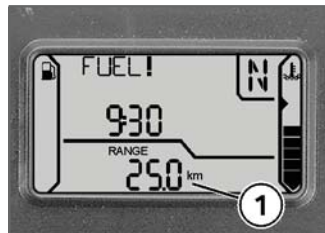

Residual range **1** is displayed with the word **RANGE** only when the fuel level has dropped to reserve. Residual range is calculated on the basis of your style of riding and the amount of fuel left in the tank; the reading indicates the estimated distance you can travel before the fuel supply runs out.

If the motorcycle is resting on its side stand, the level in the tank cannot be measured correctly, so this estimate of

residual operating range will be inaccurate.

When you refuel, the Tripmaster does not register the increase in fuel level unless several litres are added to the fuel already in the tank.

▶ The calculated range is an approximate value. Consequently, BMW Motorrad recommends that you should not try to use the full residual range before refuelling.◀

## Clock

### Setting clock



You have the option of using Tripmaster button **1** to set the clock as described below.

### Setting clock

- Switch on the ignition.

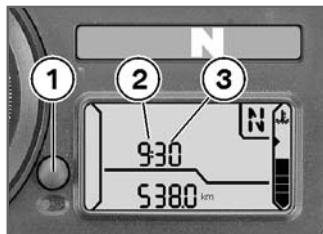

 Attempting to set the clock while riding the motorcycle can lead to accidents.

Set the clock only when the motorcycle is stationary.◀

- Repeatedly press button **1** until the Tripmaster shows the total distance covered.
- Press and hold down button **1** until the reading changes.
  - » Hours reading **2** starts to flash.
- Press button **1**.

- » The hour increments by one each time you press the button.
- Press and hold down button **1** until the reading changes.
- » Minutes reading **3** starts to flash.
- Press button **1**.
- » The minute increments by one each time you press the button.
- Press and hold down button **1** until the reading changes.
- » The reading stops flashing.
- » The time is now set.

## Emergency off switch (kill switch)

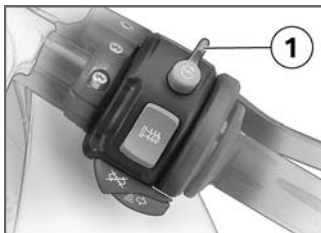

**1** Emergency off switch (kill switch).

 Operating the kill switch when riding can cause the rear wheel to lock and thus cause a fall. Do not operate the kill switch when riding.◀

The emergency off switch is a kill switch for switching off the engine quickly and easily.

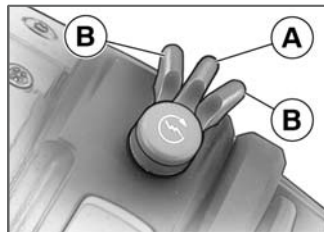

- A** Normal operating position (run)
- B** Engine switched off.

 You cannot start the engine unless the kill switch is in the run position.◀



## Grip heating<sup>OE</sup>

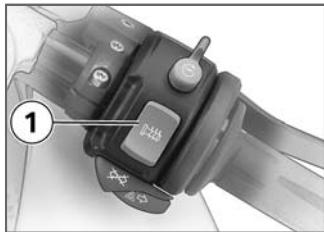

1 Grip heating switch

The handlebar grips have two-stage heating. Grip heating can be activated only when the engine is running.

▶ The increase in power consumption caused by the grip heating can drain the battery if you are riding at low engine speeds. If the charge level is low, grip heating is switched off to ensure the battery's starting capability.◀

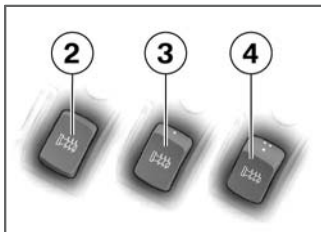

- 2 Heating off.
- 3 50 % heat output (one dot visible).
- 4 100 % heat output (three dots visible)

## Clutch

### Adjusting clutch lever

⚠ If the position of the clutch fluid reservoir is changed, air can enter the clutch system. Do not twist the handlebar fitting or the handlebars.◀

⚠ Attempting to adjust the clutch lever while riding the motorcycle can lead to accidents.

Do not attempt to adjust the clutch lever unless the motorcycle is at a standstill.◀

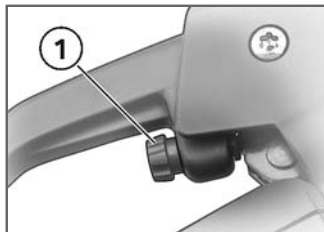

- Turn adjusting screw 1 clockwise.

▶ The adjusting screw is indexed and is easier to turn if you push the clutch lever forward.◀

» Span between handlebar grip and clutch lever increases.

- Turn adjusting screw **1** counter-clockwise.
- » Span between handlebar grip and clutch lever decreases.

## Brakes

### Adjusting handbrake lever

 Changing the position of the brake-fluid reservoir can allow air to penetrate the brake system.

Do not twist the handlebar fitting or the handlebars. ◀

 Attempting to adjust the brake lever while riding the motorcycle can lead to accidents.

Do not attempt to adjust the brake lever unless the motorcycle is at a standstill. ◀

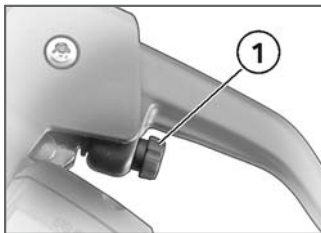

- Turn adjusting screw **1** clockwise.

 The adjusting screw is indexed and is easier to turn if you push the handbrake lever forward. ◀

- » Span between handlebar grip and handbrake lever increases.
- Turn adjusting screw **1** counter-clockwise.
- » Span between handlebar grip and handlebar lever decreases.

## Lights

### Switching on the side lights

The side lights switch on automatically when the ignition is switched on.

 The side lights place a strain on the battery. Do not switch the ignition on for longer than absolutely necessary. ◀

### Switching on the low-beam headlight

The low-beam headlight switches on automatically when you start the engine.

 When the engine is not running you can switch on the high-beam headlight by switching on the ignition and either switching on the high-beam headlight or operating the headlight flasher. ◀

## Switching on high-beam headlight



- Press the top part of switch **1** for the high-beam headlight.
- » High-beam headlight switched on.
- Move switch **1** for the high-beam headlight to the centre position.
- » High-beam headlight switched off.
- Press the bottom part of switch **1** for the high-beam headlight.

» The high-beam headlight is switched on until you release the button (headlight flasher).

## Switching on parking lights

- Switch off the ignition.

▶ You can switch on the parking lights only immediately after switching off the ignition. ◀



- Press and hold down switch **1** for the left turn

indicators until the parking lights are ON.

## Switching off parking lights

- Switch on the ignition.
- » Parking lights switched off.

## Headlight

### Adjusting headlight for driving on left/driving on right

If the motorcycle is ridden in a country where the opposite rule of the road applies, its asymmetric low-beam headlight will tend to dazzle oncoming traffic.

Have the headlight set accordingly by a specialist workshop, preferably an authorised BMW Motorrad dealer.

 Commercially available adhesive tape will damage the plastic lens of the light.

Consult a specialist workshop, preferably an authorised BMW Motorrad dealer, in order to avoid damaging the plastic lens of the light. ◀

## Headlight beam throw and spring preload

Headlight beam throw is generally kept constant when spring preload is adjusted to suit load.

Spring preload adjustment might not suffice only if the motorcycle is very heavily loaded. Under these circumstances, headlight beam throw has to be adjusted to suit the weight carried by the motorcycle.

 Consult a specialist workshop, preferably an authorised BMW Motorrad dealer, if you are unsure whether the headlight basic setting is correct. ◀

## Adjusting headlight beam throw

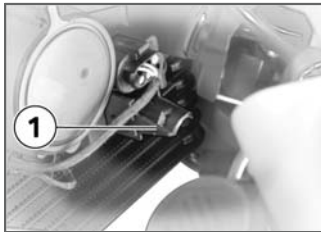

- 1 Headlight beam-throw adjustment

Moving the pivot lever adjusts headlight beam throw so as not to dazzle oncoming traffic.

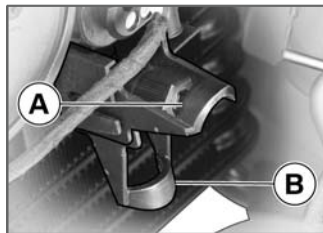

- A Neutral position
- B Position for heavy load

## Turn indicators

### Switching on left flashing turn indicators

- Switch on the ignition.



- Press left-hand turn indicator button **1**.
  - » Left-hand turn indicators switched on.
  - » Telltale light for left-hand turn indicators flashes.

### Switching on right flashing turn indicators

- Switch on the ignition.

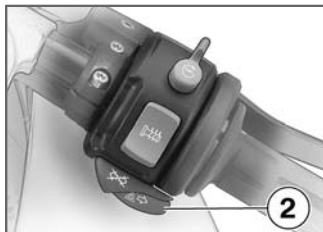

- Press right-hand turn indicator button **2**.
  - » Right-hand turn indicators switched on.
  - » Telltale light for right-hand turn indicator flashes.

### Cancelling turn indicators



- Press cancel button **3**.

 The turn indicators are cancelled automatically after you have ridden for approximately 10 seconds, or covered a distance of about 200 m. ◀

- » Flashing turn indicators switched off.
- » Turn indicator telltale light is off.

## Front and rear seats

### Removing front seat

- Make sure the ground is level and firm and place the motorcycle on its stand.

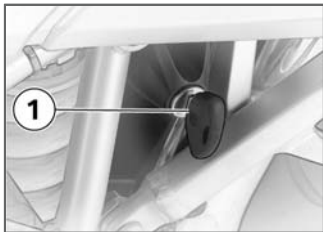

- Turn key **1** clockwise in the seat lock, while pressing down on the front part of the front seat.

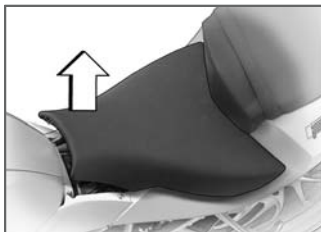

- Raise the seat at the front and lift it off the motorcycle.

### Installing front seat

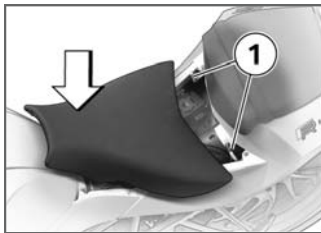

- Position the front seat in mounts **1** and press it firmly down at the front.

» The front seat engages with an audible click.

### Remove the rear seat

- Make sure the ground is level and firm and place the motorcycle on its stand.
- Removing front seat (→ 44)



- Pull and hold loop **1** and pull the rear seat forward to remove.

## Installing rear seat



- Position the rear seat in mounts **1** and push it back.  
» The rear seat engages with two audible clicks.

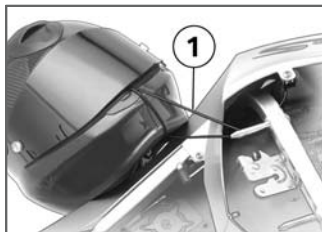

**!** The helmet catch can scratch the panelling. Make sure the lock is out of the way when you hook the helmet into position. ◀

- Use the wire rope available as an optional extra to secure the helmet to helmet holder **1**.

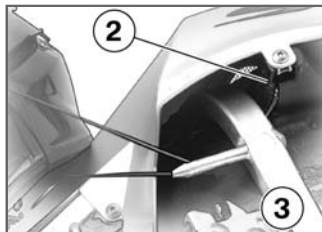

- Guide the wire rope underneath rear frame **3** and slip the eyes of the wire rope into helmet-holder slot **2**.
- Installing rear seat (➡ 45)

## Helmet holder

### Using helmet holder

- Make sure the ground is level and firm and place the motorcycle on its stand.
- Remove the rear seat (➡ 44)

## Mirrors

### Adjusting mirrors

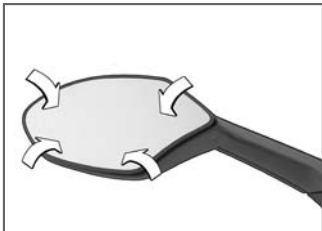

- Move the mirror to the desired position by pressing it lightly close to the edge.

## ABS<sup>OE</sup>

### Deactivatable ABS

Under certain circumstances, it can be best to dispense with ABS when you ride on loose surfaces or in practice sessions. Consequently, you have the option of temporarily

deactivating this motorcycle's ABS function.

Note the detailed description of the ABS system, which starts on page (➔ 64).

### Deactivating ABS function

- Switch on the ignition, or bring the motorcycle to a stop.



- Press and hold down ABS button **1**.

**ABS** ABS warning light ON.

- When the ABS warning light comes on, release the ABS button within five seconds.

 The warnings for 'ABS fault' and 'ABS OFF' are identical. ◀

- » The ABS function is deactivated.

**ABS** ABS warning light remains ON.

### Activating ABS function

- Bring the motorcycle to a standstill.





▶ If you switch the ignition off then on again and the ABS light comes back on, there is a fault in the ABS. ◀

## Suspension settings

### Spring preload and weight

It is essential to set spring preload of the rear suspension to suit the load carried by the motorcycle. Increase spring preload when the motorcycle is heavily loaded and reduce spring preload accordingly when the motorcycle is lightly loaded.

### Spring preload and road-surface condition with sport suspension<sup>OE</sup>

The spring preload of the front suspension can be adjusted to the rider's weight

to suit the terrain and the intended use.

## Shock-absorber settings and spring preload

Damping must be adapted to suit spring preload. An increase in spring preload requires firmer damping, a reduction in spring preload requires softer damping.

## Settings, standard suspension

### Adjusting spring preload for rear wheel

 Your motorcycle's handling will suffer if you do not match the spring-preload and damping-characteristic settings.

Adjust the damping characteristic to suit spring preload. ◀

- Press and hold down ABS button **1**.
  - » The ABS warning light goes out.
- When the ABS warning light goes out, release the ABS button within five seconds.
  - » The ABS warning light remains off.
  - » The ABS function is activated.
- Instead of pressing the ABS button, you have the option of switching the ignition off and then on again.

- Make sure the ground is level and firm and place the motorcycle on its stand.



- If you want to increase spring preload, use the tool from the on-board toolkit to turn adjusting ring **1** clockwise.
- If you want to reduce spring preload, use the tool from the on-board toolkit to turn adjusting ring **1** counter-clockwise.

 Spring preload, basic setting

Turn adjusting ring to stage 2. (Motorcycle with full load of fuel, with rider 85 kg)

### Adjusting damping for rear wheel



Your motorcycle's handling will suffer if you do not match the spring-preload and damping-characteristic settings.

Adjust the damping characteristic to suit spring preload. ◀

- Make sure the ground is level and firm and place the motorcycle on its stand.



- Adjust the rear shock absorber, using a screwdriver to turn adjusting screw **1**.



- If you want a harder damping characteristic, use a screwdriver to turn adjust-

ing screw **1** in the direction indicated by the H arrow.

- If you want a softer damping characteristic, use a screwdriver to turn adjusting screw **1** in the direction indicated by the S arrow.

 Rear suspension damping, basic setting

Turn adjusting screw clockwise to limit stop (H), then back it off 3/4 of a turn. (Motorcycle with full load of fuel, with rider 85 kg)

## Settings, sport suspension<sup>OE</sup>

### Adjusting spring preload for front wheel

- Make sure the ground is level and firm and place the motorcycle on its stand.

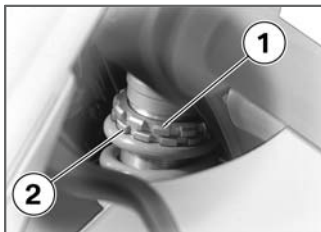

- Use adjusting rings **1** and **2** to adjust spring preload.

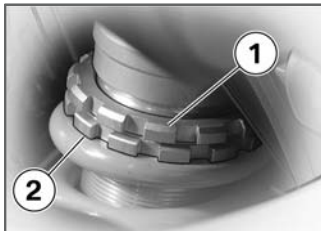

- Use the tool from the on-board toolkit to hold adjusting ring **2**.
- Use the tool from the on-board toolkit to release the

lock by turning adjusting ring **1** counter-clockwise.

- If you want to increase spring preload, turn adjusting ring **2** clockwise.
- If you want to reduce spring preload, turn adjusting ring **2** counter-clockwise.

 Spring preload, basic setting

With OE Sport suspension: 184 mm (Motorcycle with full load of fuel, with rider weighing 85 kg)◀

- When you have adjusted spring preload, use the tool from the on-board toolkit to hold adjusting ring **2**.
- Use the tool from the on-board toolkit to turn adjusting ring **1** clockwise until it is locked against adjusting ring **2**.

## Adjusting damping characteristic for front wheel

 Your motorcycle's handling will suffer if you do not match the spring-preload and damping-characteristic settings.

Adjust the damping characteristic to suit spring preload. ◀

- Make sure the ground is level and firm and place the motorcycle on its stand.

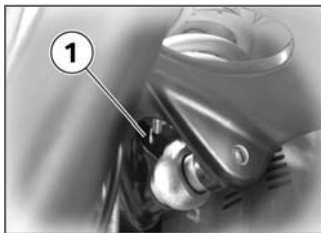

- Adjust damping by turning adjusting ring **1**.

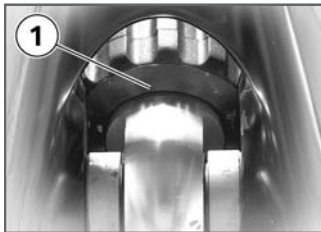

- If you want to increase damping, turn adjusting ring **1** counter-clockwise.

- If you want to reduce damping, turn adjusting ring **1** clockwise.

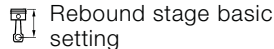

With OE Sport suspension:  
Turn bottom knob clockwise to limit stop, then back it off 16 clicks. (Motorcycle with full load of fuel, with rider 85 kg) ◀

## Adjusting spring preload for rear wheel

 Your motorcycle's handling will suffer if you do not match the spring-preload and damping-characteristic settings.

Adjust the damping characteristic to suit spring preload. ◀

 Adjusting spring preload while the motorcycle is

being ridden can lead to accidents.

Do not attempt to adjust spring preload unless the motorcycle is at a standstill. ◀

- Make sure the ground is level and firm and place the motorcycle on its stand.

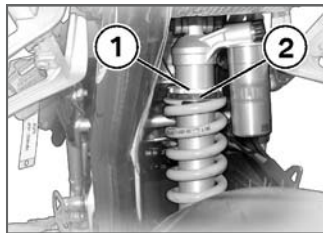

- Use adjusting rings **1** and **2** to adjust spring preload.

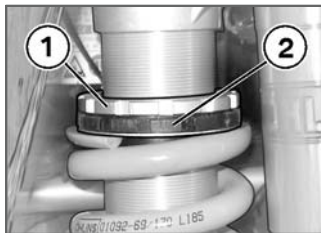

- Use the tool from the on-board toolkit to hold adjusting ring **2**.
- Use the tool from the on-board toolkit to release the lock by turning adjusting ring **1** counter-clockwise.
- If you want to increase spring preload, turn adjusting ring **2** clockwise.
- If you want to reduce spring preload, turn adjusting ring **2** counter-clockwise.



Spring preload, basic setting

With OE Sport suspension:  
85 kg (Motorcycle with full load of fuel, with rider)  
158 mm (Spring length (no load on rear wheel))◀

### Adjusting rebound-stage damping for rear wheel

- Make sure the ground is level and firm and place the motorcycle on its stand.

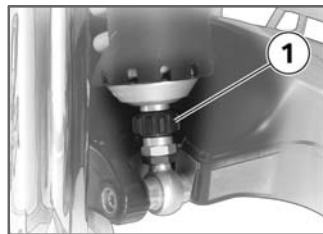

- Adjust rebound-stage damping by turning adjusting ring **1**.



- If you want to increase rebound-stage damping, turn adjusting ring **1** counter-clockwise.
- If you want to reduce rebound-stage damping, turn adjusting ring **1** clockwise.

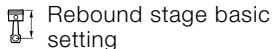

Rebound stage basic setting

With OE Sport suspension:  
Turn bottom knob (on piston rod) clockwise to limit stop, then back it off 16 clicks. (Motorcycle with full load of fuel, with rider 85 kg)◀

## Adjusting compression-stage damping for rear wheel

- Make sure the ground is level and firm and place the motorcycle on its stand.



- Adjust compression-stage damping by turning adjusting ring **1**.



- If you want to increase compression-stage damping, turn adjusting ring **1** in the H direction.
- If you want to reduce compression-stage damping, turn adjusting ring **1** in the S direction.

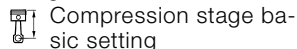

Compression stage basic setting

With OE Sport suspension:  
Turn top knob (on reservoir) clockwise to limit stop, then back it off 14 clicks. (Motorcycle with full load of fuel, with rider 85 kg)◀

## Setting length of spring strut

- Make sure the ground is level and firm and place the motorcycle on its stand.
- Removing rear wheel (➔ 86)

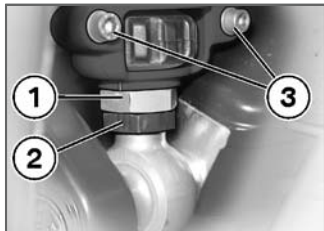

- Slacken screws **3** of the spray guard.
- Back off nut **2** by turning it clockwise.
- If you want to increase the length of the spring strut, turn nut **1** counter-clockwise.

- If you want to reduce the length of the spring strut, turn nut **1** clockwise.
- Once you have set the spring strut to the desired length, turn nut **2** counter-clockwise to lock the adjuster.

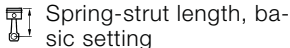

With OE Sport suspension:  
Turn the bottom spring retain-  
er down as far as it will go.  
(Motorcycle with full load of  
fuel, with rider 85 kg)◀

- Align the spray guard as shown in the illustration.
- Tighten screws **3** of the spray guard.
- Installing rear wheel (➔ 86)

## Tyres

### Checking tyre pressures

 Incorrect tyre pressure adversely affects the handling characteristics of the motorcycle and can lead to accidents.

Always check that the tyre pressures are correct.◀

 At high road speeds, tyre valves have a tendency to open as a result of centrifugal force.

In order to avoid a sudden loss of tyre pressure, fit a metal valve cap with rubber sealing ring to the rear tyre and make sure that the cap is screwed on firmly.◀

 Incorrect tyre pressure reduces the operating life of the tyres.

Always check that the tyre pressures are correct.◀

- Check tyre pressures against the data below.



Tyre pressure, front

2.2 bar (One-up, tyre cold)

2.5 bar (Two-up and/or with luggage, tyre cold)



Tyre pressure, rear

2.5 bar (One-up, tyre cold)

2.9 bar (Two-up and/or with luggage, tyre cold)

If tyre pressure is too low:

- Correct tyre pressure.



## **Riding**

Safety instructions .....	56
Checklist .....	58
Starting .....	58
Running in .....	60
Parking your motorcycle .....	61
Refuelling .....	62
Brake system, general .....	63
Brake system with BMW Motorrad ABS <sup>OE</sup> .....	64

## Safety instructions

### Rider's equipment

Do not ride without the correct clothing. Always wear:

- Helmet
- Motorcycling jacket and trousers
- Gloves
- Boots

This applies even to short journeys, and to every season of the year. Your authorised BMW Motorrad dealer will be glad to advise you on the correct clothing for every purpose.

### Speed

If you ride at high speed, always bear in mind that various boundary conditions can adversely affect the handling of your motorcycle:

- settings of the spring-strut and shock-absorber system
- imbalanced load
- loose clothing
- insufficient tyre pressure
- poor tyre tread
- etc.

### Correct loading



Overloading and imbalanced loads can adversely affect the motorcycle's handling.

Do not exceed the permissible gross weight and be sure to comply with the instructions on loading. ◀

### Alcohol and drugs



Even small amounts of alcohol or drugs will adversely affect your perception and your ability to assess situations and make decisions, and slow down your

reflexes. Medication can exacerbate these effects.

Do not ride your motorcycle after consuming alcohol, drugs and/or medication. ◀

### Risk of poisoning

Exhaust fumes contain carbon monoxide, which is colourless and odourless but highly toxic.



Inhaling the exhaust fumes therefore represents a health hazard and can even cause loss of consciousness with fatal consequences.

Do not inhale exhaust fumes. Do not run the engine in an enclosed space. ◀

## High voltage

 Touching live parts of the ignition system with the engine running can cause electric shock.

Do not touch parts of the ignition system when the engine is running. ◀

## Catalytic converter

If misfiring causes unburned fuel to enter the catalytic converter, there is a danger of overheating and damage.

For this reason, observe the following points:

- Do not run the fuel tank dry.
- Do not attempt to start or run the engine with a spark-plug cap disconnected.
- Stop the engine immediately if it misfires.
- Use only unleaded fuel.
- Comply with all specified maintenance intervals.

 Unburned fuel will destroy the catalytic converter.

Note the points listed for protection of the catalytic converter. ◀

## Risk of fire

Temperatures at the exhaust are high.

 Flammable materials (e.g. hay, leaves, grass, clothing and luggage, etc.) could ignite if allowed to come into contact with the hot exhaust pipe.

Do not permit flammable materials to come into contact with the hot exhaust system. ◀

 Cooling would be inadequate if the engine were allowed to idle for a lengthy period with the motorcycle at a standstill: overheating would result.

In extreme cases, the motorcycle could catch fire. Do not allow the engine to idle unnecessarily. Ride away immediately after starting the engine. ◀

## Tampering with the control unit of the electronic engine-management system

 Tampering with the control unit of the electronic engine-management system can damage the motorcycle and cause accidents. Do not tamper with the control unit of the electronic engine-management system. ◀

 Tampering with the control unit of the electronic engine-management system can result in mechanical loads that the motorcycle's com-

ponents are not designed to withstand. Damage caused in this way is not covered by the warranty.

Do not tamper with the control unit of the electronic engine-management system. ◀

## Checklist

Use the following checklist to check important functions, settings and wear limits before you ride off.

- Brakes
- Brake-fluid levels, front and rear
- Clutch
- Clutch fluid level
- Shock absorber setting and spring preload
- Tyre-tread depth and tyre pressures

- Cases correctly installed and luggage secured

At regular intervals:

- Engine oil level (every refuelling stop)
- Brake-pad wear (every third refuelling stop)

## Starting

### Side stand

You cannot start the motorcycle with the side stand extended and a gear engaged. The engine will switch itself off if you start it with the gearbox in neutral and then engage a gear before retracting the side stand.

### Gearbox

You can start the engine when the gearbox is in neutral or if you pull the clutch with a gear engaged. Do not pull the clutch until after you have

switched on the ignition, as otherwise the engine will refuse to start. When the gearbox is in neutral, the green neutral telltale light is on and the gear indicator in the multifunction display shows 0.

## Starting engine

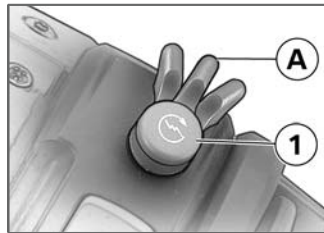

- Kill switch **1** in run position **A**.
- Switch on the ignition.
- » Pre-ride check is performed. (➡ 59)

With OE Anti-lock braking system (ABS):

- Switch on the ignition.
  - » Pre-ride check is performed. (➡ 59)
  - » ABS self-diagnosis is performed. (➡ 60)◀



- Press starter button **1**.

▶ If ambient temperatures are very low, you might find it necessary to open the throttle slightly when starting the engine. At ambient temperatures below 0 °C, disen-

gage the clutch after switching on the ignition.◀

▶ The start attempt is automatically interrupted if battery voltage is too low. Recharge the battery before you start the engine, or use jump leads and a donor battery to start.◀

- » The engine starts.
- » Consult the troubleshooting chart below if the engine refuses to start. (➡ 108)

### Pre-ride check

The instrument cluster runs a test of the 'General' warning light when the ignition is switched on. The warning light shows first yellow and then red, so that you can check that it is in working order. This pre-ride check is indicated by the word CHECK! appearing in the display. The

test is aborted if you start the engine before it completes.

### Phase 1

⚠ General warning light shows red.

- The CHECK! reminder appears on the display.

### Phase 2

⚠ General warning light shows yellow.

- The CHECK! reminder appears on the display.

If the 'General' warning light is not displayed:

⚠ Some malfunctions cannot be indicated if the 'General' warning light cannot be displayed.

Check that the 'General' warning light comes on, and that it lights up yellow and then red.◀

- Have the fault rectified as quickly as possible by a specialist workshop, preferably an authorised BMW Motorrad dealer.

## ABS warning lights<sup>OE</sup>



Version 1.



Version 2.

The description below is based on version 1.

## ABS self-diagnosis<sup>OE</sup>

BMW Motorrad ABS performs self-diagnosis to ensure its operability. Self-diagnosis is performed automatically when you switch on the ignition. The motorcycle has to move forward a few metres for the wheel sensors to be tested.

### Phase 1

- » Test of the diagnosis-compatible system components with the motorcycle at a standstill.



ABS warning light flashes once per second.

### Phase 2

- » Test of the wheel sensors as the motorcycle pulls away from rest.



ABS warning light flashes once per second.

### Phase 3

- » ABS self-diagnosis completed.
- » The ABS warning light goes out.

If an indicator showing an ABS fault appears when ABS self-diagnosis completes:

- You can continue to ride. Bear in mind that the ABS function is not available.
- Have the fault rectified as quickly as possible by a specialist workshop, preferably an authorised BMW Motorrad dealer.

## Running in

### The first 1000 km

- While running in the motorcycle, vary the throttle opening and engine-speed range frequently.
- Try to do most of your riding during this initial period on twisting, fairly hilly roads, avoiding high-speed main roads and highways if possible.



Exceeding the specified engine speeds while running in will lead to increased engine wear.

Keep to the specified engine speeds for running in. ◀

- Do not exceed the rpm limits recommended for running in.



Running-in speed

4000 min<sup>-1</sup>

- No full-load acceleration.
- Avoid low engine speeds at full load.
- Do not omit the first inspection after 500 - 1200 km.

## Brake pads

New brake pads must "bed down" and therefore do not achieve their optimum friction levels during the first 500 km. You can compensate for this initial reduction in braking efficiency by exerting greater pressure on the levers.



New brake pads can extend stopping distance by a significant margin. Apply the brakes in good time. ◀

## Tyres

New tyres have a smooth surface. This must be roughened by riding in a restrained manner at various heel angles until the tyres are run in. This running in procedure is essential if the tyres are to achieve maximum grip.



Tyres do not have their full grip when new and there is a risk of accident at extreme angles of heel. Avoid extreme angles of heel. ◀

## Parking your motorcycle

### Placing motorcycle on side stand



If the ground is soft or uneven, there is no guarantee that the motorcycle will rest firmly on the stand. Always check that the ground under the stand is level and firm. ◀

- Switch off the engine.
- Pull the handbrake lever.
- Hold the motorcycle upright and balanced.
- Use your left foot to extend the side stand fully.



The side stand is designed to support only the weight of the motorcycle. Do not lean or sit on the motorcycle with the side stand extended. ◀

- Slowly lean the motorcycle to the side until its weight is taken by the stand and dismount to the left.

 If the motorcycle is on the side stand, the surface of the ground will determine whether it is better to turn the handlebars to the left or right. However, the motorcycle is more stable on a level surface with the handlebars turned to the left than with the handlebars turned to the right.

On level ground, always turn the handlebars to the left to set the steering lock.◀

- Turn the handlebars to full left or right lock.
- Check that the motorcycle is standing firmly.

 On a gradient, the motorcycle should always face uphill; select 1st gear.◀

## Removing motorcycle from side stand

- Unlock the steering lock.
- From the left, grip the handlebars with both hands.
- Pull the handbrake lever.
- Swing your right leg over the seat and lift the motorcycle to the upright position.
- Hold the motorcycle upright and balanced.

 An extended side stand can catch on the ground when the motorcycle is moving and lead to a fall. Retract the side stand before moving the motorcycle.◀

- Sit on the motorcycle and use your left foot to retract the side stand.

## Refuelling

 Fuel is highly flammable. A naked flame close to the fuel tank can cause a fire or explosion.

Do not smoke. Never bring a naked flame near the fuel tank.◀

 Fuel expands when hot. Fuel escaping from an overfilled tank could make its way onto the rear tyre. This could cause a fall.

Do not fill the tank past the bottom edge of the filler neck.◀

 Fuel attacks plastics, which become dull or unsightly.

Wipe off plastic parts immediately if they come into contact with fuel.◀



 Leaded fuel will destroy the catalytic converter. Use only unleaded fuel. ◀

- Make sure the ground is level and firm and place the motorcycle on its stand.

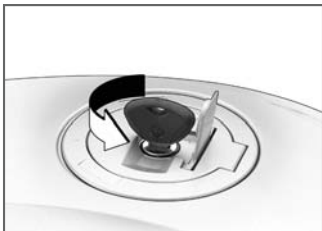

- Open the protective cap.
- Open the fuel tank cap with the ignition key by turning it counter-clockwise.
- Refuel with fuel of the grade stated below.

▶ The ratings for performance and consumption

are quoted for the recommended grade of fuel. ◀

 Recommended fuel grade

Super Plus unleaded (98 RON / 88 MON)

 Fuel grade, usable with power- and consumption-related restrictions

Super unleaded (95 RON / 85 MON)

 Fuel capacity, usable

17 l

 Fuel capacity, reserve

4 l

- Press the filler cap down firmly to close.
- Remove the key and close the protective cap.

## Brake system, general

### Descending mountain passes

 There is a danger of the brakes fading if you use only the rear brakes when descending mountain passes. Under extreme conditions, the brakes could overheat and suffer severe damage. Use both front and rear brakes, and make use of the engine's braking effect as well. ◀

### Wet brakes

 After the motorcycle has been washed, ridden through water or ridden in the rain, the brake discs and pads might be wet and the brakes might not take effect immediately. Apply the brakes in good time

until the brakes have dried out. ◀

### **Salt on brakes**

 The brakes may fail to take effect immediately if the motorcycle was ridden on salt-covered roads and the brakes were not applied for some time.

Apply the brakes in good time until the salt layer on the brake discs and brake pads has been removed. ◀

### **Oil or grease on brakes**

 Oil and grease on the brake discs and pads considerably diminish braking efficiency.

Especially after repair and maintenance work, make sure that the brake discs and brake pads are free of oil and grease. ◀

### **Dirt or mud on brakes**

 When riding on loose surfaces or muddy roads, the brakes may fail to take effect immediately because of dirt or moisture on the discs or brake pads.

Apply brakes in good time until the brakes have been cleaned. ◀

 The brake pads will wear more rapidly if you ride frequently on unsurfaced tracks or poor roads.

Check the thickness of the brake pads more frequently and replace the brake pads in good time. ◀

## **Brake system with BMW Motorrad ABS<sup>OE</sup>**

### **How does ABS work?**

The amount of braking force that can be transferred to the road depends on factors that include the coefficient of friction of the road surface. Loose stones, ice and snow or a wet road all have much lower coefficients of friction than a clean, dry asphalt surface. The lower the coefficient of friction, the longer the braking distance.

If the rider increases braking pressure to the extent that braking force exceeds the maximum transferrable limit, the wheels start to lock and the motorcycle loses its directional stability; a fall is imminent. Before this situation can occur, ABS intervenes and adapts braking pressure

to the maximum transferrable braking force, so the wheels continue to turn and directional stability is maintained irrespective of the condition of the road surface.

### **What are the effects of surface irregularities?**

Humps and surface irregularities can cause the wheels to lose contact temporarily with the road surface; if this happens the braking force that can be transmitted to the road can drop to zero. If the brakes are applied under these circumstances the ABS has to reduce braking force to ensure that directional stability is maintained when the wheels regain contact with the road surface. At this instant the BMW Motorrad ABS must assume an extremely low coefficient of friction, so

that the wheels will continue to rotate under all imaginable circumstances, because this is the precondition for ensuring directional stability. As soon as it registers the actual circumstances, the system reacts instantly and adjusts braking force accordingly to achieve optimum braking.

### **How can stopping distance be minimised?**

Each time the brakes are applied, a load distribution shift takes place with the load shifting forward from the rear to the front wheel. The sharper the motorcycle decelerates, the more load is shifted to the front wheel. The higher the wheel load, the more braking force can be transmitted without the wheel locking.

To optimise stopping distance, apply the front brakes rapidly and keep on increasing the force you apply to the brake lever. This makes the best possible use of the dynamic increase in load at the front wheel. Remember to pull the clutch at the same time. In the "panic braking situations" that are trained so frequently braking force is applied as rapidly as possible and with the rider's full force applied to the brake levers; under these circumstances the dynamic shift in load distribution cannot keep pace with the increase in deceleration and the tyres cannot transmit the full braking force to the surface of the road. ABS has to intervene to keep the front wheel from locking; this increases stopping distance.

## Reserves for safety

The potentially shorter braking distances which BMW Motorrad ABS permits must not be used as an excuse for careless riding. ABS is primarily a means of ensuring a safety margin in genuine emergencies.

Take care when cornering. When you apply the brakes on a corner, the motorcycle's weight and momentum take over and even BMW Motorrad ABS is unable to counteract their effects.

## Rear wheel lift

Even under severe braking, a high level of tyre grip can mean that the front wheel does not lock up until very late, if at all. Consequently, ABS does not intervene until very late, if at all. Under these circumstances the rear wheel

can lift off the ground, and the outcome can be a highsiding situation in which the motorcycle can flip over.



Severe braking can cause the rear wheel to lift off the ground. When you brake, bear in mind that ABS control cannot be relied on in all circumstances to prevent the rear wheel from lifting clear of the ground.◀

## What is the design baseline for BMW Motorrad ABS?

Within the limits imposed by physics, BMW Motorrad ABS ensures directional stability on any surface. The system is not optimised for special requirements that apply under extreme competitive situations off-road or on the track.

## Special situations

The speeds of the front and rear wheels are compared as one means of detecting a wheel's incipient tendency to lock. If the system registers implausible values for a lengthy period the ABS function is deactivated for safety reasons and an ABS fault message is issued. Self-diagnosis has to complete before fault messages can be issued. In addition to problems with the BMW Motorrad ABS, exceptional riding conditions can lead to a fault message being issued.

### Exceptional riding conditions:

- Riding for a lengthy period with the front wheel lifted off the ground (wheely).
- Rear wheel rotating with the motorcycle held stationary

- by applying the front brake (burn-out).
- Heating up with the motorcycle on the centre stand or an auxiliary stand, engine idling or with a gear engaged.
  - Rear wheel locked for a lengthy period, for example while descending off-road.

torrad Integral ABS is always maintained in optimum condition, it is essential for you to comply strictly with the specified inspection intervals. ◀

If a fault message is issued on account of exceptional riding conditions as outlined above, you can reactivate the ABS function by switching the ignition off and on again.

### **What significance devolves on regular maintenance?**



Invariably, a technical system cannot perform beyond the abilities dictated by its level of maintenance. To ensure that the BMW Mo-



## **Accessories**

General instructions .....	70
Power socket .....	70

## General instructions

BMW Motorrad recommends the use of parts and accessories for your motorcycle that are approved by BMW for this purpose.

Genuine BMW parts and accessories and other products which BMW has approved can be obtained from your authorised BMW Motorrad dealer, together with expert advice on their installation and use.

These parts and products have been tested by BMW for safety, function and suitability. BMW accepts product liability for them.

Conversely, BMW is unable to accept any liability whatsoever for parts and accessories which it has not approved.



BMW Motorrad cannot assess each non-BMW product to determine whether it can be used on or in connection with BMW motorcycles without constituting a safety hazard. Country-specific official authorisation does not suffice as assurance. Tests conducted by these instances cannot make provision for all operating conditions experienced by BMW motorcycles and, consequently, they are not sufficient in some circumstances. Use only parts and accessories approved by BMW for your motorcycle. ◀

Whenever you are planning modifications, comply with all the legal requirements. Make sure that the motorcycle does not infringe national road-vehicle construction and use regulations.

## Power socket Ratings

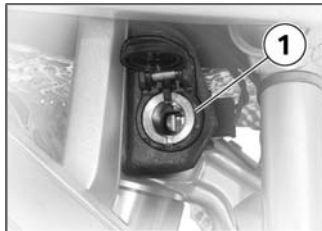

The supply to socket **1** is cut off automatically if battery voltage is low or the load exceeds the maximum rating.

### Operating electrical accessories

You can start using electrical accessories only when the ignition is switched on. The accessory remains operational if the ignition is subsequently switched off. In order to ensure that the drain on the on-



board power supply system is minimised, the supply to the power socket is cut off approximately 15 minutes after the ignition is switched off, and it is also temporarily interrupted during the start procedure.

### **Cable routing**

The cables from the power socket to the auxiliary device must be routed in such a way that they:

- do not impede the rider
- do not restrict or obstruct the steering angle and handling characteristics
- cannot be trapped



Incorrectly routed cables can impede the rider.

Route the cables as described above. ◀



## Maintenance

General instructions .....	74	Jump start .....	96
Toolkit .....	74	Battery .....	97
Additional toolkit for sport suspension (OE) .....	74		
Engine oil .....	74		
Brake system, general .....	76		
Brake pads .....	77		
Brake fluid .....	78		
Clutch .....	80		
Tyres .....	81		
Rims .....	81		
Wheels .....	81		
Front-wheel stand .....	87		
Rear wheel stand .....	88		
Bulbs .....	89		

## General instructions

The Maintenance chapter describes straightforward procedures for checking and replacing certain wear parts. Special tightening torques are listed as applicable. The tightening torques for the threaded fasteners on your motorcycle are listed in the section entitled "Technical data".

You will find information on more extensive maintenance and repair work in the Repair Manual on CD-ROM (RePROM) for your motorcycle, which is available from your authorised BMW Motorrad dealer.

## Toolkit

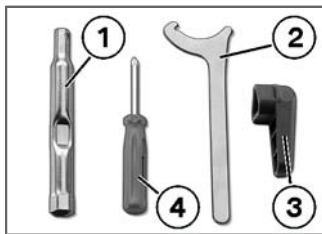

- 1 Extension, hook wrench
- 2 Hook wrench
- 3 Lever for cap, oil filler neck
- 4 Screwdriver, reversible, with cross-head/plain blades

▶ A supplementary on-board toolkit for more complicated maintenance work on your motorcycle is available from BMW Motorrad. You can obtain additional

information from your authorised BMW Motorrad dealer. ◀

## Additional toolkit for sport suspension (OE)

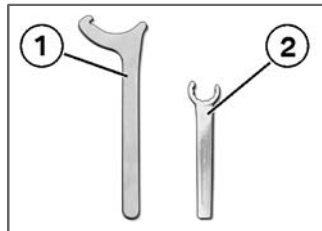

- 1 Second hook wrench
- 2 Wrench for adjusting spring-strut length

## Engine oil

### Checking engine oil level



The engine can seize if the oil level is low, and this can lead to accidents.

Always make sure that the oil level is correct. ◀

 The oil level varies with the temperature of the oil. The higher the temperature, the higher the level of oil in the sump. Checking the oil level with the engine cold or after no more than a short ride will lead to misinterpretation; this in turn, means that the engine will be operated with the incorrect quantity of oil.

In order to ensure that the engine oil level is read correctly, check the oil level only after a lengthy trip. ◀

 The insufficient oil pressure warning does not fulfil the function of an oil gauge. The only way of checking whether the oil level is correct is to check the oil sight glass. ◀

- Check that the engine is at operating temperature, make sure that the ground is level and firm and place the motorcycle on its stand.
- Wait five minutes after switching off the engine.
- Hold the motorcycle upright.

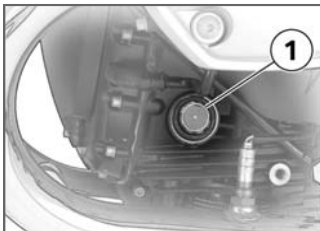

- Check the oil level in oil-level indicator **1**.

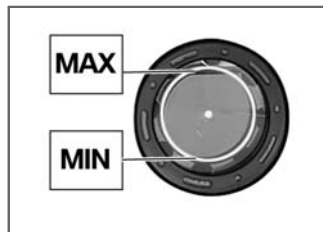

 Engine oil, specified level

Between MIN and MAX marks

If the oil level is below the MIN mark:

- Top up the engine oil.

If the oil level is above the MAX mark:

- Have the oil level corrected by a specialist workshop, preferably an authorised BMW Motorrad dealer.

## Topping up the engine oil

- Checking engine oil level (➔ 74)



**!** Damage to the engine can result if it is operated without enough oil, but the same also applies if the oil level is too high. Always make sure that the oil level is correct. ◀

- Wipe the area around the filler neck clean.
- Use the tool from the toolkit to remove cap **1** from the engine oil filler neck.

- Top up the engine oil to the specified level.
- Use the tool from the toolkit to install the cap in the engine oil filler neck.

## Brake system, general Dependability of the brake system

A fully functional brake system is a basic requirement for the road safety of your motorcycle.

Do not ride the motorcycle if you have any doubts about the dependability of the brake system.

Under these circumstances have the brake system checked by a specialist workshop, preferably an authorised BMW Motorrad dealer.

**!** Incorrect working practices endanger the reliability of the brakes. Have all work on the brake system performed by a specialist workshop, preferably an authorised BMW Motorrad dealer. ◀

## Checking brake operation

- Pull the handbrake lever.
    - » The pressure point must be clearly perceptible.
  - Press the footbrake lever.
    - » The pressure point must be clearly perceptible.
- If pressure points are not clearly perceptible:
- Have the brakes checked by a specialist workshop, preferably an authorised BMW Motorrad dealer.

## Brake pads

### Checking brake-pad thickness, front brakes

 Brake pads worn past the minimum permissible thickness can cause a reduction in braking efficiency and under certain circumstances they can cause damage to the brake system.

In order to ensure the dependability of the brake system, do not permit the brake pads to wear past the minimum permissible thickness. ◀

- Make sure the ground is level and firm and place the motorcycle on its stand.



- Visually inspect the left and right brake pads to ascertain their thickness. Viewing direction: Between wheel and fork tube toward the brake caliper.

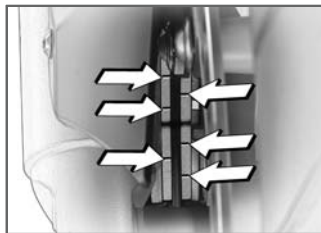

 Brake-pad wear-indicating marks, front

The wear-indicating marks must be clearly visible on the pads.

If the wear indicating marks are no longer clearly visible:

- Have the brake pads replaced by a specialist workshop, preferably an authorised BMW Motorrad dealer.

## Checking brake pad thickness, rear brakes

**!** Brake pads worn past the minimum permissible thickness can cause a reduction in braking efficiency and under certain circumstances they can cause damage to the brake system.

In order to ensure the dependability of the brake system, do not permit the brake pads to wear past the minimum permissible thickness. ◀

- Make sure the ground is level and firm and place the motorcycle on its stand.



- Visually inspect the brake pads of the rear brake caliper from the left to ascertain their thickness.

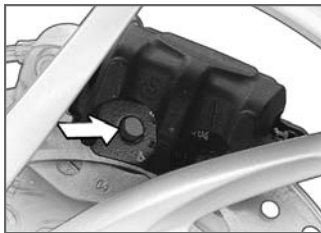

Brake-pad thickness, rear

Make sure that the brake disc is not visible through the bore in the inboard brake block.

If the brake disc is visible:

- Have the brake pads replaced by a specialist workshop, preferably an authorised BMW Motorrad dealer.

## Brake fluid

### Checking brake-fluid level, front brakes

**!** A low fluid level in the brake reservoir can allow air to penetrate the brake system. This significantly reduces braking efficiency. Check the brake-fluid level at regular intervals. ◀

- Make sure the ground is level and firm and hold the motorcycle upright.



- Move the handlebars to the straight-ahead position.



- Check the brake fluid level in front reservoir **1**.

▶ Wear of the brake pads causes the brake fluid level in the reservoir to sink.◀



 Brake fluid level, front

Do not permit the brake fluid level to drop below the MIN mark. (Motorcycle upright and handlebars in straight-ahead position)

If the brake fluid level drops below the permitted level:

- Have the defect rectified as quickly as possible by a specialist workshop, preferably an authorised BMW Motorrad dealer.

## Checking brake-fluid level, rear brakes

 A low fluid level in the brake reservoir can allow air to penetrate the brake system. This significantly reduces braking efficiency. Check the brake-fluid level at regular intervals.◀

- Make sure the ground is level and firm and hold the motorcycle upright.



- Check the brake fluid level in rear reservoir **1**.

▶ Wear of the brake pads causes the brake fluid level in the reservoir to sink. ◀



 Brake fluid level, rear

Do not permit the brake fluid level to drop below the MIN mark. (motorcycle upright)

If the brake fluid level drops below the permitted level:

- Have the defect rectified as quickly as possible by a specialist workshop, preferably an authorised BMW Motorrad dealer.

## Clutch

### Checking operation of the clutch

- Pull the clutch lever.
    - » The pressure point must be clearly perceptible.
- If the pressure point is not clearly perceptible:
- Have the clutch checked by a specialist workshop, preferably an authorised BMW Motorrad dealer.

### Checking the clutch fluid level

- Make sure the ground is level and firm and hold the motorcycle upright.
- Move the handlebars to the straight-ahead position.



- Check the clutch fluid level in reservoir **1**.

▶ Wear of the clutch causes the fluid level in the clutch fluid reservoir to rise. ◀

▶ The clutch system is filled with a special hydraulic fluid that does not have to be changed. ◀

 Clutch fluid level

Do not permit the clutch fluid level to drop.

If the fluid level drops:



Unsuitable hydraulic fluids could cause damage to the clutch system.

Do not attempt to top up the system with fluids of any kind. ◀

- Have the defect rectified as quickly as possible by a specialist workshop, preferably an authorised BMW Motorrad dealer.

## Tyres

### Checking tyre tread depth



Your motorcycle's handling and grip can be impaired even before the tyres wear to the minimum tyre tread depth permitted by law. Have the tyres changed in good time before they wear

to the minimum permissible tread depth. ◀

- Make sure the ground is level and firm and place the motorcycle on its stand.
- Measure the tyre tread depth in the main tread grooves with wear marks.

 Tyres have wear indicators integrated into the main tread grooves. The tyre is worn out when the tyre tread has worn down to the level of the marks. The locations of the marks are indicated on the edge of the tyre, e.g. by the letters TI, TWI or by an arrow. ◀

If the tyre tread no longer complies with the minimum legally required tread depth:

- Replace tyre.

## Rims

### Checking rims

- Make sure the ground is level and firm and place the motorcycle on its stand.
- Visually inspect the rims for defects.
- Have damaged rims checked and, if necessary, replaced by a specialist workshop, preferably an authorised BMW Motorrad dealer.

## Wheels

### Approved wheels and tyres

For each size of tyre BMW Motorrad tests certain makes, and approves those that it certifies as roadworthy. If BMW Motorrad has not approved the wheels and tyres, it cannot assess their suitability.

ility or provide any guarantee of road safety.

Use only wheels and tyres approved by BMW Motorrad for your type of motorcycle.

You can obtain detailed information from your authorised BMW Motorrad dealer or on the Internet at [www.bmw-motorrad.com](http://www.bmw-motorrad.com).

## Removing front wheel

- Place the motorcycle on an auxiliary stand; BMW Motorrad recommends the BMW Motorrad rear-wheel stand.
- Fit the rear wheel stand (→ 89)

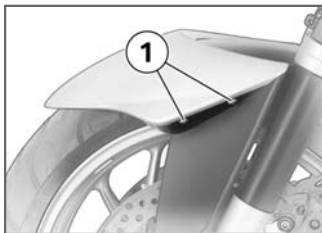

- Remove screws **1** on left and right.
- Lift the mudguard up and forward, pulling the two sides slightly apart.

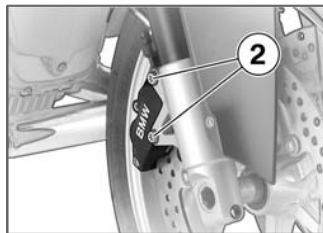

- ! Once the calipers have been removed, there is a risk of the brake pads being pressed together to the extent that they cannot be slipped back over the brake disc on reassembly. Do not operate the handbrake lever when the brake calipers have been removed.◀
- Remove securing screws **2** of the left and right brake calipers.

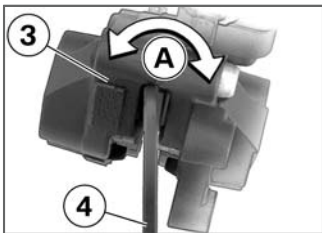

- Force the brake pads slightly apart by rocking brake calipers **3** back and forth **A** against brake discs **4**.
- Mask off the parts of the wheel rim that could be scratched in the process of removing the brake calipers.
- Carefully pull the brake calipers back and out until clear of the brake discs.

With OE Anti-lock braking system (ABS):

- When removing the left brake caliper, take care not

to damage the ABS sensor cable.◀

- Raise the front of the motorcycle until the front wheel can rotate freely. BMW Motorrad recommends the BMW Motorrad front wheel stand for lifting the motorcycle.
- Fit the front wheel stand (➡ 87)

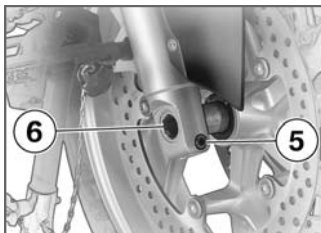

- Release axle clamping screw **5**.

- Remove quick-release axle **6**, while supporting the wheel.

▶ BMW Motorrad can supply an adapter for removing the quick-release axle. This adapter can be combined with any commercially available w/f 22 open-end or ring spanner. The BMW special tool number is 363691 and the adapter is available from your authorised BMW Motorrad dealer. The supplementary toolkit available as an optional accessory also includes a tool for removing the quick-release axle.◀

- Roll the front wheel forward to remove.

With OE Anti-lock braking system (ABS):

- Do not damage the ABS sensor on the left-hand side when rolling out the wheel.<

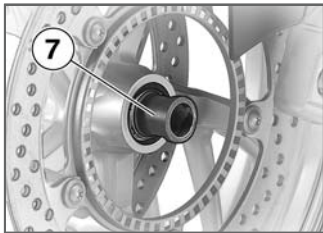

- Remove spacing bushing **7** from the left-hand side of the wheel hub.

### Installing front wheel

**!** Threaded fasteners not tightened to the specified torque can work loose or their threads can suffer damage.

Always have the security of

the fasteners checked by a specialist workshop, preferably an authorised BMW Motorrad dealer.<

**!** There is a risk of damaging parts of the front brake, particularly the BMW Motorrad ABS, in the course of the procedure described below.

Take care not to damage the brake system, in particular the ABS sensor with cable and the ABS sensor ring.<

**!** The front wheel must be installed right way round to rotate in the correct direction.

Note the direction-of-rotation arrows on the tyre or the wheel rim.<

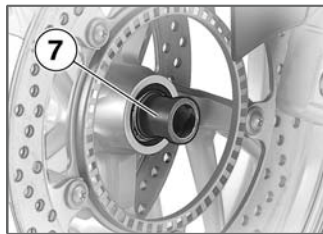

- Slip spacing bushing **7** into the left-hand side of the wheel hub.
- Roll the front wheel into position between the front forks.

With OE Anti-lock braking system (ABS):

- Do not damage the ABS sensor on the left-hand side when rolling in the wheel.<

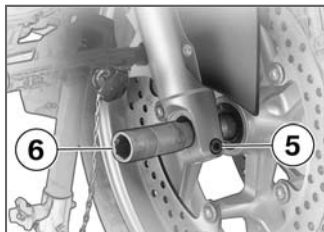

- Raise the front wheel, insert quick-release axle **6** and tighten to specified torque.

 Quick-release axle in axle holder

50 Nm

- Tighten axle clamping screw **5** to the specified torque.

 Quick-release axle clamp screws

19 Nm

- Remove the front wheel stand.
- Ease the brake calipers on to the brake discs.

With OE Anti-lock braking system (ABS):

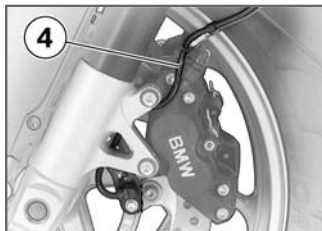

 The cable of the ABS sensor could chafe through if it comes into contact with the brake disc. Make sure that the ABS sensor cable is routed snugly along the front suspension. ◀

- Route ABS sensor cable **4** as illustrated here. ◀

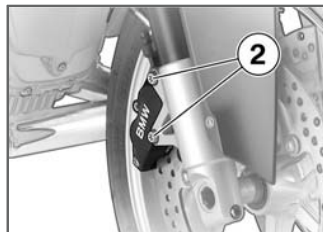

- Install securing screws **2** and tighten to specified torque.

 Brake caliper to slider tube

30 Nm

- Remove the adhesive tape from the wheel rim.

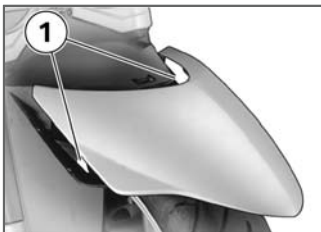

- Seat the mudguard in holder **1**.
- Install the screws on left and right.
- Operate the brake several times until the brake pads are bedded.
- Remove the rear-wheel stand, if installed.

## Removing rear wheel

 Parts of the exhaust system can be hot.

Do not touch hot parts of the exhaust system. ◀

- Place the motorcycle on an auxiliary stand; BMW Motorrad recommends the BMW Motorrad rear-wheel stand.
- Fit the rear wheel stand (➔ 89)
- Engage first gear.

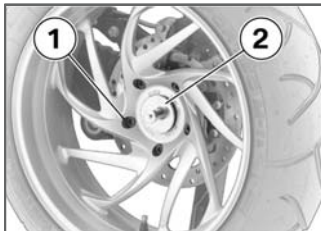

- Place a support underneath the rear wheel and remove 5 studs **1**.
- If applicable, remove lock washer **2** of the rear-wheel stand.
- Lower the rear wheel to the ground.

- Roll the rear wheel out toward the rear.

## Installing rear wheel

 Threaded fasteners not tightened to the specified torque can work loose or their threads can suffer damage.

Always have the security of the fasteners checked by a specialist workshop, preferably an authorised BMW Motorrad dealer. ◀

- Check that the wheel adapter and wheel hub are free of grease.
- Place the rear wheel on the wheel adapter.



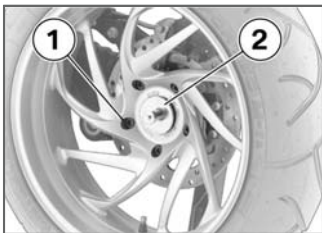

## Front-wheel stand

### Use

A front wheel stand for simple, safe changing of the front wheel is available from BMW Motorrad. The BMW special tool number is 36 3 970 and the front-wheel stand is available from your authorised BMW Motorrad dealer.

**!** The BMW Motorrad front wheel stand is not designed to support motorcycles not fitted with a centre stand or without other auxiliary stands. A motorcycle resting only on the front wheel stand and the rear wheel can topple.

Place the motorcycle on its centre stand or another auxiliary stand before lifting the

- If applicable, install lock washer **2** of the auxiliary stand.
- Hand-tighten wheel studs **1** and then tighten to specified torque in diagonally opposite sequence.

 Rear wheel to wheel carrier

60 Nm

Tightening sequence: in diagonally opposite sequence

- Remove the auxiliary stand.

front wheel with the BMW Motorrad front-wheel stand. ◀

### Fit the front wheel stand

- Place the motorcycle on an auxiliary stand; BMW Motorrad recommends the BMW Motorrad rear-wheel stand.
- Fit the rear wheel stand (➔ 89)



- Slacken adjusting screws **1**.
- Push the two pins **2** apart until the front forks fit between them.

- Use locating pins **3** to set the front wheel stand to the desired height.
- Centre the front wheel stand relative to the front wheel and push it against the front axle.

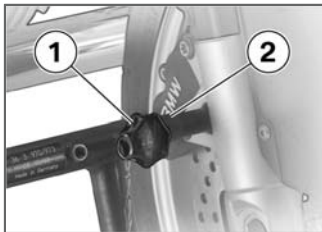

- Push both mounting pins **2** through the triangles of the brake caliper anchorages just far enough to allow the front wheel to be rolled between them.

 There is a risk of damaging the ABS sensor ring of the BMW Motorrad ABS.

Push the pin in just far enough to ensure that it clears the sensor ring of the BMW Motorrad ABS. ◀

- Tighten adjusting screws **1**.

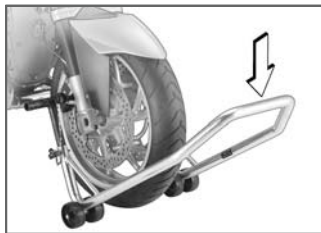

- Apply uniform pressure to push the front wheel stand down and raise the motorcycle.

## Rear wheel stand

### Rear wheel stand

BMW Motorrad offers a rear-wheel stand for holding motorcycles (including those without centre stands) securely upright for maintenance work. The BMW special tool number is 36 3 980 and the rear-wheel stand is available from your authorised BMW Motorrad dealer.

## Fitting rear wheel stand



- Use screws **1** to set the rear-wheel stand to the desired height.
- Remove retaining disc **2**. To do so, press release button **3**.



- Push the rear-wheel stand from the right onto the rear axle.
- Push the retaining disc on from the left, while holding the unlock button down.
- Grip the rear grab handle of the motorcycle with your left hand and use your right to grip the lever of the rear wheel stand **4**.



- Lift the motorcycle upright, simultaneously pressing the lever down until the stand supports the motorcycle in the upright position.
- Press the lever down to the ground.

## Bulbs

### General instructions

A warning appears in the multifunction display if a bulb is defective.



A defective bulb places your safety at risk because it is easier for other

users to oversee you and your motorcycle.

Replace defective bulbs as soon as possible; always carry a complete set of spare bulbs if possible. ◀

**!** The bulb is pressurised and can cause injury if damaged.

Wear protective goggles and gloves when changing bulbs. ◀

▷ The types of bulb fitted to your motorcycle are listed in the section entitled "Technical data". ◀

▷ Do not touch the glass of new bulbs with your fingers. Use a clean, dry cloth to hold the bulbs when handling them. Dirt deposits, in particular oil and grease, interfere with heat radiation from the bulb. This leads to

overheating and shortens the bulb's operating life. ◀

## Replacing high-beam/low-beam headlight bulb

**!** If it is not standing firmly, the motorcycle could topple in the course of the operations described below. Always make sure that the motorcycle is stable and firmly supported. ◀

- Make sure the ground is level and firm and place the motorcycle on its stand.
- Switch off the ignition.

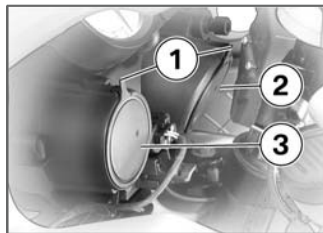

- Remove cover **2** (low-beam headlight) or cover **3** (high-beam headlight) by pulling lever **1**.

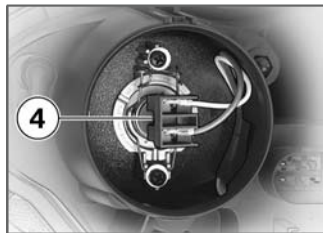

- Disconnect plug **4**.



- Disengage spring clips **5** from the fastenings and swing them aside.

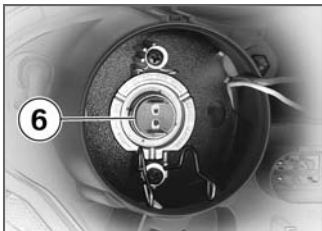

- Remove bulb **6**.
- Replace the defective bulb.

 High-beam headlight bulb

H7 / 12 V / 55 W

 Low-beam headlight bulb

H7 / 12 V / 55 W



- Insert the bulb; make sure that projection **7** is correctly positioned (high-beam headlight down / low-beam headlight up) and make check that the bulb engages correctly.

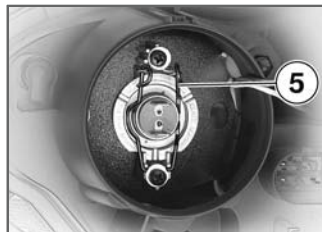

- Close and lock spring clips **5**.

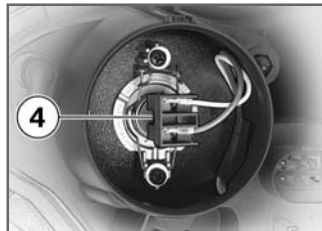

- Connect plug **4**.

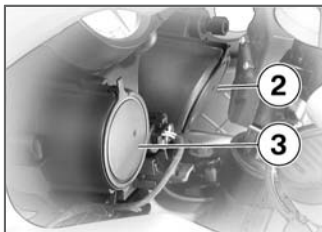

- Install cover **2** (low-beam headlight) or cover **3** (high-beam headlight).

## Replacing parking-light bulb

**!** If it is not standing firmly, the motorcycle could topple in the course of the operations described below. Always make sure that the motorcycle is stable and firmly supported. ◀

- Make sure the ground is level and firm and place the motorcycle on its stand.

- Switch off the ignition.

▶ Turn the handlebars to the left to facilitate access. ◀

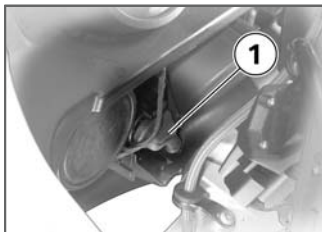

- Remove cap **1**.

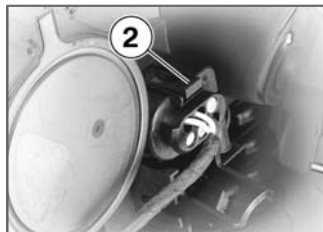

- Disconnect plug **2**.



- Remove bulb holder **3** by turning it counter-clockwise.

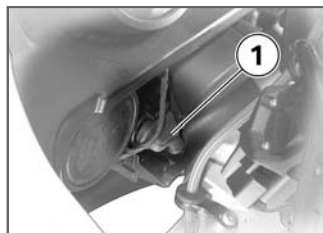
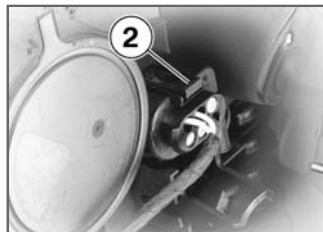
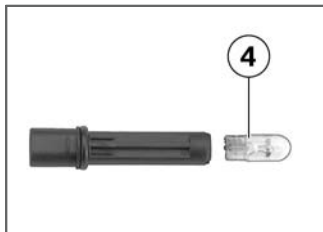
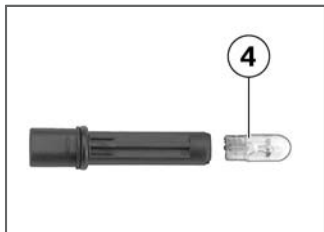

- Remove bulb **4** from the bulb holder.
- Replace the defective bulb.

- Push bulb **4** into its socket.

- Connect plug **2**.

 Parking-light bulb

- Turn bulb socket **3** clock-wise to install.

- Install cap **1**.

W5W / 12 V / 5 W

## Replacing front turn indicator bulb

**!** If it is not standing firmly, the motorcycle could topple in the course of the operations described below. Always make sure that the motorcycle is stable and firmly supported. ◀

- Make sure the ground is level and firm and place the motorcycle on its stand.
- Switch off the ignition.

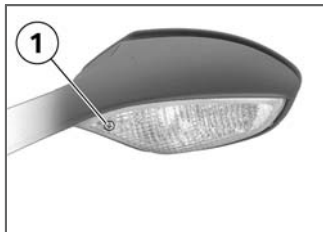

- Remove screw **1**.



- Pull the bulb housing out of the mirror housing at the threaded-fastener side.

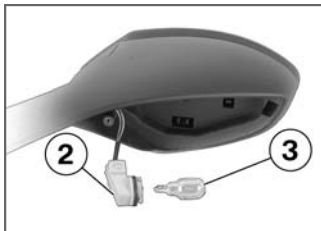

- Remove the bulb holder **2** from the bulb housing by turning it counter-clockwise.

- Remove bulb **3** from the bulb holder.
- Replace the defective bulb.

Front flashing turn indicator bulbs  
R10W / 12 V / 10 W

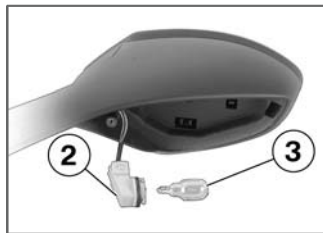

- Insert bulb **3** into the bulb socket.
- Turn bulb socket **2** clockwise to install it in the bulb housing.
- Seat the bulb housing in the mirror shell.



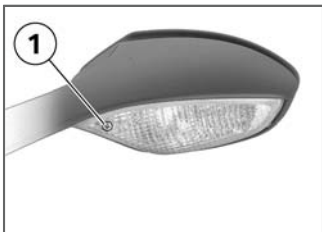

- Install screw **1**.



- Remove screw **1**.

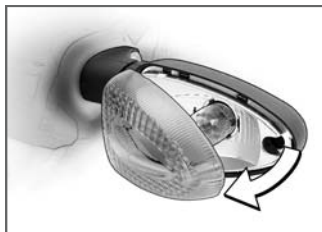

- Pull the glass out of the reflector housing at the threaded-fastener side.

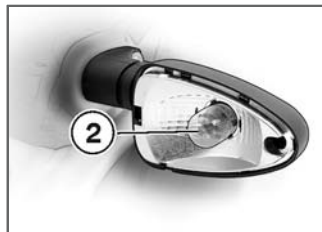

- Turn bulb **2** counter-clockwise and remove it from the bulb housing.
  - Replace the defective bulb.
-  Rear flashing turn indicator bulbs

R10W / 12 V / 10 W

## Replacing rear turn indicator bulb

 If it is not standing firmly, the motorcycle could topple in the course of the operations described below. Always make sure that the motorcycle is stable and firmly supported. ◀

- Make sure the ground is level and firm and place the motorcycle on its stand.

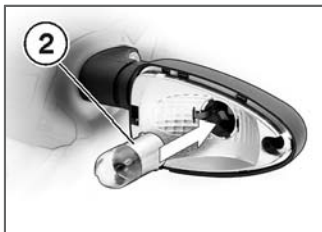

- Turn bulb **2** clockwise to install it in the bulb housing.



- Working from the inboard side, insert the glass into the bulb housing and close the housing.



- Install screw **1**.

## Jump start

 The wires leading to the power socket do not have a load-capacity rating adequate for jump-starting the engine. Excessively high current can lead to a cable fire or damage to the vehicle electronics.

Do not use the on-board socket to jump-start the engine of the motorcycle. ◀

 Touching live parts of the ignition system with the engine running can cause electric shock.

Do not touch parts of the ignition system when the engine is running. ◀

 A short-circuit can result if the crocodile clips of the jump leads are accidentally brought into contact with the motorcycle.

Use only jump leads fitted with fully insulated crocodile clips at both ends. ◀

 Jump-starting with a donor-battery voltage higher than 12 V can damage the vehicle electronics. Make sure that the battery of the donor vehicle has a voltage rating of 12 V. ◀

- Make sure the ground is level and firm and place the motorcycle on its stand.

- Removing front seat (⇒ 44)
- When jump-starting the engine, do not disconnect the battery from the on-board electrical system.

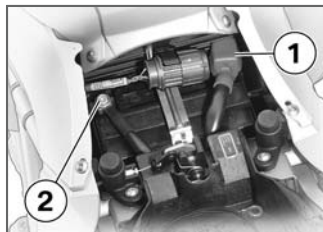

- Remove the protective cap from the battery's positive terminal **1**.
- Run the engine of the donor vehicle during jump-starting.
- Begin by connecting one end of the red jump lead to the positive terminal of the discharged battery and the other end to the pos-

itive terminal of the donor battery.

- Then connect one end of the black jump lead to the negative terminal of the donor battery, and the other end to negative terminal **2** of the discharged battery.
- Start the engine of the vehicle with the discharged battery in the usual way; if the engine does not start, wait a few minutes before repeating the attempt in order to protect the starter motor and the donor battery.
- Allow both engines to idle for a few minutes before disconnecting the jump leads.
- Disconnect the jump lead from the negative terminals **2** first, then disconnect the second jump lead from the positive terminals **1**.

Do not use proprietary start-assist sprays or other products to start the engine. ◀

- Installing front seat (⇒ 44)

## Battery

### Maintenance instructions

Correct upkeep, recharging and storage will prolong the life of the battery and are essential if warranty claims are to be considered.

Compliance with the points below is important in order to maximise battery life:

- Keep the surface of the battery clean and dry
- Do not open the battery
- Do not top up with water
- Be sure to read and comply with the instructions for charging the battery on the following pages

- Do not turn the battery upside down



If the battery is not disconnected, the on-board electronics (e.g. clock, etc.) gradually drain the battery. This can cause the battery to run flat. If this happens, warranty claims will not be accepted.

If the motorcycle is to be out of use for more than four weeks, disconnect the battery or connect a suitable trickle charger to the battery. ◀



BMW Motorrad has developed a trickle-charger specially designed for compatibility with the electronics of your motorcycle. Using this charger, you can keep the battery charged during long periods of disuse, without having to disconnect the battery from the motorcycle's

on-board systems. You can obtain additional information from your authorised BMW Motorrad dealer. ◀

### Charging battery when connected



Charging the connected battery directly at the battery terminals can damage the vehicle electronics.

Always disconnect the battery from the on-board circuits before recharging it with a charger connected directly to the battery posts. ◀



Only chargers suitable for this mode of charging can be used to recharge the battery via the on-board socket. Unsuitable chargers could cause damage to the motorcycle's on-board electrics.

Use BMW chargers with the part numbers 71 60

7 688 864 (220 V) or, as applicable, 71 60 7 688 865 (110 V). If you are in doubt, disconnect the battery from the on-board systems and connect the charger directly to the battery. ◀



If you switch on the ignition and the multifunction display and telltale lights fail to light up, the battery is completely flat. Attempting to charge a completely flat battery via the on-board socket can cause damage to the motorcycle's electronics.

If a battery has discharged to the extent that it is completely flat, it has to be disconnected from the on-board circuits and charged with the charger connected directly to the battery posts. ◀

- Charge via the power socket, with the battery connec-

ted to the motorcycle's on-board electrical system.

- Comply with the operating instructions of the charger.

▷ The motorcycle's on-board electronics know when the battery is fully charged. The on-board socket is switched off when this happens.◀

### Charging battery when disconnected

- Charge the battery using a suitable charger.
- Comply with the operating instructions of the charger.
- Once the battery is fully charged, disconnect the charger terminal clips from the battery terminals.

▷ The battery has to be recharged at regular intervals in the course of a lengthy period of disuse. See the in-

structions for caring for your battery. Always fully recharge the battery before restoring it to use◀

### Remove the battery

- Make sure the ground is level and firm and place the motorcycle on its stand.
- Removing front seat (➡ 44)
- Switch off the ignition.

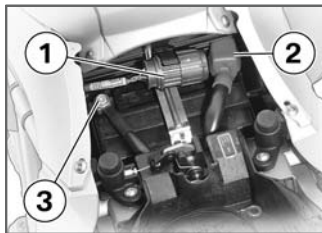

- Remove the screw and remove battery retainer 4.



Disconnection in the wrong sequence increases the risk of short-circuits.

Always proceed in the correct sequence.◀

- Disconnect negative lead **3** first.
- Then pull back protective cap **2** of the positive terminal and disconnect the positive lead.

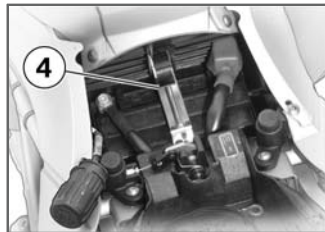

- Remove the screw and remove battery retainer **4**.

- Lift the battery up and out; work it slightly back and forth if it is difficult to remove.

### Installing battery

- Make sure the ground is level and firm and place the motorcycle on its stand.
- Switch off the ignition.
- Insert the battery into the battery compartment, with the positive terminal on the right in the direction of travel.

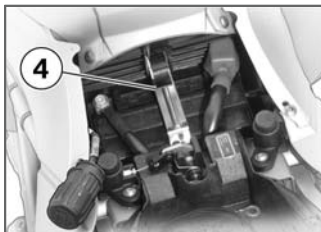

- Slip battery retainer **4** over the battery and install the screw.

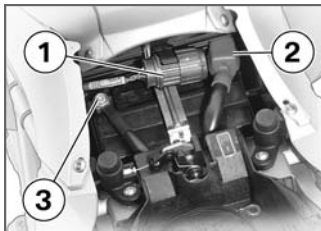

 Installation in the wrong sequence increases the risk of short-circuits.

Always proceed in the correct sequence.

Never install the battery without the protective cap. ◀

- Connect the positive lead to the positive terminal.
- Install protective cap **2**.
- Connect negative lead **3** to the negative terminal.
- Seat diagnosis plug **1** in the holder.
- Installing front seat (⇒ 44)
- Set the clock (⇒ 37)

## Care

Care products .....	102
Washing motorcycle .....	102
Cleaning easily damaged components .....	103
Paint care .....	104
Protective wax coating .....	104
Laying up motorcycle .....	104
Restoring motorcycle to use .....	105

## Care products

BMW Motorrad recommends that you use the cleaning and care products you can obtain from your authorised BMW Motorrad dealer. The substances in BMW Care Products have been tested in laboratories and in practice; they provide optimised care and protection for the materials used in your vehicle.

 The use of unsuitable cleaning and care products can damage vehicle components.

Do not use solvents such as cellulose thinners, cold cleaners, fuel or the like, and do not use cleaning products that contain alcohol. ◀

## Washing motorcycle

BMW Motorrad recommends that you use BMW insect remover to soften and wash off insects and stubborn dirt on painted parts prior to washing the motorcycle.

To prevent stains, do not wash the motorcycle immediately after it has been exposed to strong sunlight and do not wash it in the sun. Make sure that the motorcycle is washed frequently, especially during the winter months.

To remove road salt, clean the motorcycle with cold water immediately after every trip.

 After the motorcycle has been washed, ridden through water or ridden in the rain, the brake discs and pads might be wet and the

brakes might not take effect immediately.

Apply the brakes in good time until the brakes have dried out. ◀

 Warm water intensifies the effect of salt.

Use only cold water to wash off road salt. ◀

 The high pressure of steam cleaners can damage seals, the hydraulic brake system, the electrical system, and the seat.

Do not use a steam jet or high-pressure cleaning equipment. ◀



## Cleaning easily damaged components

### Plastics

Clean plastic parts with water and BMW plastic care emulsion. This includes in particular:

- Windscreen and slipstream deflectors
- Headlight lens made of plastic
- Glass cover of the instrument cluster
- Black, unpainted parts

 If plastic parts are cleaned using unsuitable cleaning agents, the surfaces can be damaged.

Do not use cleaning agents that contain alcohol, solvents or abrasives to clean plastic parts.

Even fly-remover pads or cleaning pads with hard

surfaces can produce scratches. ◀

 Soften stubborn dirt and insects by covering the affected areas with a wet cloth. ◀

### Windscreen

Clean off dirt and insects with a soft sponge and plenty of water.

 Fuel and chemical solvents attack the material of the windscreen; the windscreen becomes opaque or dull. Do not use cleaning agents. ◀

### Chrome

Use plenty of water and BMW shampoo to clean chrome, particularly if it has been exposed to road salt. Use chrome polish for additional treatment.

### Radiator

Clean the radiator regularly to prevent overheating of the engine due to inadequate cooling.

For example, use a garden hose with low water pressure.

 Cooling fins can be bent easily. Take care not to bend the fins when cleaning the radiator. ◀

### Rubber

Treat rubber components with water or BMW rubber-care products.

 Using silicone sprays for the care of rubber seals can cause damage. Do not use silicone sprays or other care products that contain silicon. ◀

## Paint care

Washing the motorcycle regularly will help counteract the long-term effects of substances that damage the paint, especially if your motorcycle is ridden in areas with high air pollution or natural sources of dirt, for example tree resin or pollen.

Remove particularly aggressive substances immediately, however, as otherwise the paint can be affected or become discoloured. Substances of this nature include spilt fuel, oil, grease, brake fluid and bird droppings. We recommend BMW vehicle polish or BMW paint cleaner for this purpose.

Marks on the paintwork are particularly easy to see after the motorcycle has been washed. Remove stains of

this kind immediately, using cleaning-grade benzene or petroleum spirit on a clean cloth or ball of cotton wool. BMW Motorrad recommends BMW tar remover for removing specks of tar. Remember to wax the parts treated in this way.

## Protective wax coating

BMW Motorrad recommends applying only BMW car wax or products containing carnauba wax or synthetic wax.

It is time to re wax the paintwork when water "puddles" on the surface, instead of forming beads.

## Laying up motorcycle

- Clean the motorcycle.
- Remove the battery.

- Spray the brake and clutch lever pivots, the side stand pivots and the centre stand pivots (if the motorcycle is fitted with a centre stand) with a suitable lubricant.
- Coat bright metal and chrome-plated parts with an acid-free grease (e.g. Vaseline).
- Stand the motorcycle in a dry room in such a way that there is no load on either wheel.

 Before laying the vehicle up out of use, have the engine oil and the oil filter element changed by a specialist workshop, preferably an authorised BMW Motorrad dealer. Combine work for laying up/restoring to use with a BMW service or inspection.◀

## Restoring motorcycle to use

- Remove the protective wax coating.
- Clean the motorcycle.
- Install a charged battery.
- Before starting: work through the checklist.



## Technical data

Troubleshooting chart .....	108
Threaded fasteners .....	109
Engine .....	110
Riding specifications .....	112
Clutch .....	112
Transmission .....	112
Final drive .....	113
Running gear .....	113
Brakes .....	115
Wheels and tyres .....	115
Electrics .....	116
Frame .....	118
Dimensions .....	118
Weights .....	119

## Troubleshooting chart

Engine does not start at all or is difficult to start.

<b>Possible cause</b>	<b>Remedy</b>
Kill switch activated.	Kill switch in operating position (run).
Side stand extended and gear engaged.	Retract the side stand (➡ 58).
Gear engaged and clutch not disengaged.	Select neutral or pull clutch lever (➡ 58).
Clutch pulled when ignition was OFF	Switch on the ignition, then pull the clutch lever.
No fuel in tank.	Refuelling (➡ 62)
Battery not adequately charged.	Charge the battery when connected (➡ 98)

## Threaded fasteners

<b>Front wheel</b>	<b>Value</b>	<b>Valid</b>
<b>Quick-release axle clamp screws</b>		
M8 x 35	19 Nm	
<b>Quick-release axle in axle holder</b>		
M24 x 1.5	50 Nm	
<b>Brake caliper to slider tube</b>		
M8 x 32	30 Nm	
<b>Rear wheel</b>	<b>Value</b>	<b>Valid</b>
<b>Rear wheel to wheel carrier</b>		
M10 x 40 x 1.25	<b>in diagonally opposite sequence</b>	
	60 Nm	

## Engine

Engine design	Four-stroke opposed twin, air-cooled with oil-cooled exhaust ports, installed longitudinally, two overhead camshafts, electronic engine management
Effective displacement	1170 cm <sup>3</sup>
Cylinder bore	101 mm
Piston stroke	73 mm
Compression ratio	12.5 : 1
Nominal output	90 kW, - at engine speed: 8250 min <sup>-1</sup>
Maximum torque	112 Nm, - at engine speed: 6800 min <sup>-1</sup>
With OE Power reduction:	102 Nm, - at engine speed: 4800 min <sup>-1</sup>
Idle speed	1150±50 min <sup>-1</sup>

### Fuel

Recommended fuel grade	Super Plus unleaded (98 RON / 88 MON)
Fuel grade, usable with power- and consumption-related restrictions	Super unleaded (95 RON / 85 MON)
Fuel capacity, usable	17 l
Fuel capacity, reserve	4 l



<b>Engine oil</b>	
Engine oil, capacity	4 l, with filter change
Lubricant	Engine oil, 20W-50
Engine oil, quantity for topping up	0.5 l, difference between MIN and MAX
Oil grades	Engine oils of API classification SF or better. Engine oils of ACEA classification A2 or better. BMW Motorrad recommends not using synthetic oils for the first 10,000 km. Please do not hesitate to contact your authorised BMW Motorrad dealer if you have any questions relating the choice of a suitable engine oil for your motorcycle.
<b>Permissible viscosity classes</b>	
SAE 5 W- $\geq 30$	-20...20 °C, Operation at low temperatures
SAE 10 W-40	-10...30 °C, Operation at moderate temperatures
SAE 15 W- $\geq 40$	$\geq 0$ °C
SAE 20 W- $\geq 40$	$\geq 0$ °C
SAE 5 W- $\geq 50$	$\geq -20$ °C, High-grade and synthetic oils, operation in all temperature ranges
SAE 10 W- $\geq 50$	$\geq -20$ °C, High-grade and synthetic oils, operation in all temperature ranges

## Riding specifications

Top speed	>200 km/h
Acceleration 0-100 km/h	3.15 s

## Clutch

Clutch type	Single dry plate with high-leverage pressure plate
-------------	----------------------------------------------------

## Transmission

Gearbox type	Helical 6-speed gearbox with integral reaction damper, claw-action shift by sliding sleeves
--------------	---------------------------------------------------------------------------------------------

### Gear ratios

Primary transmission ratio	1.824 (31:17 teeth)
Gear ratio, 1st gear	2.277 (41:18 teeth)
Gear ratio, 2nd gear	1.583 (38:24 teeth)
Gear ratio, 3rd gear	1.259 (34:27 teeth)
Gear ratio, 4th gear	1.033 (31:30 teeth)
Gear ratio, 5th gear	0.903 (28:31 teeth)
Gear ratio, 6th gear	0.805 (29:36 teeth)

## Final drive

Final drive, type	Shaft drive with bevel gears
Final drive gear ratio	2.62:1

## Running gear

Front suspension, type	BMW Telelever, leading link pivot-mounted on engine and telescopic forks, central spring strut supported by leading link and main frame
With OE Sport suspension:	BMW Telelever, with anti-dive top fork bridge, leading link pivot-mounted on engine and telescopic forks, with adjustable rebound-stage damping and adjustable spring preload, central spring strut supported by leading link and main frame
Spring strut, front, type	Central spring strut with coil spring and twin-tube, gas-filled shock absorber
With OE Sport suspension:	Central spring strut with coil spring and twin-tube, gas-filled shock absorber, adjustable rebound damping and adjustable spring preload
Front suspension, total suspension travel	110 mm, At wheel

Rear wheel guidance, type	BMW Paralever, consisting of rear wheel swinging arm with central spring strut, reaction link supported by final-drive housing and frame.
Rear suspension type	Central spring strut with single-tube, gas-filled shock absorber, progressive compression-stage damping, steplessly adjustable rebound-stage damping and adjustable spring preload
With OE Sport suspension:	Central spring strut with single-tube, gas-filled shock absorber, external expansion tank, adjustable rebound-stage and progressive compression-stage damping, steplessly adjustable spring preload and length adjustment
Total spring travel at rear wheel	120 mm

## Brakes

Front brakes, type	Hydraulically operated twin disc brake with 4-piston fixed calipers and floating brake discs
Brake-pad material, front	Sintered metal
Rear brakes, type	Hydraulically operated disc brake with 2-piston floating calliper and brake disc fixed to final drive
Brake-pad material, rear	Organic material

## Wheels and tyres

Front wheel, type	Cast aluminium wheel with 5 double spokes, MT H2
Front wheel rim size	3.50" x 17"
Tyre designation, front	120/70-17
Rear wheel type	Cast aluminium wheel with 5 double spokes, MT H2
Rear wheel rim size	5.50" x 17"
With OE Wide tyres:	6.00" x 17"

Tyre designation, rear	180/55-17
With OE Wide tyres:	190/50-17
<b>Tyre pressures</b>	
Tyre pressure, front	2.2 bar, One-up, tyre cold 2.5 bar, Two-up and/or with luggage, tyre cold
Tyre pressure, rear	2.5 bar, One-up, tyre cold 2.9 bar, Two-up and/or with luggage, tyre cold

## Electrics

Rating of on-board socket	5 A
Fuses	Electronic fuses protect the circuits. If an electronic fuse trips and de-energises a circuit, the circuit is active as soon as the ignition is switched on after the fault has been rectified.

## Battery

Battery type	AGM (Absorbent Glass Mat) battery
Battery rated voltage	12 V
Battery rated capacity	14 Ah

**Spark plugs**

Spark plug manufacturer and designation	Bosch YR5LDE
Spark plug electrode gap	0.8±0.1 mm, When new
Spark plug electrode gap	1 mm, Wear limit

**Lighting**

High-beam headlight bulb	H7 / 12 V / 55 W
Low-beam headlight bulb	H7 / 12 V / 55 W
Parking-light bulb	W5W / 12 V / 5 W
Front flashing turn indicator bulbs	R10W / 12 V / 10 W
Rear flashing turn indicator bulbs	R10W / 12 V / 10 W

## Frame

Frame type	Tubular spaceframe with steel front and centre sections, aluminium rear section and load-bearing drive unit
Type plate, location	Front panel carrier, inboard, right
Vehicle identification number (VIN), location	Frame front section, top centre

## Dimensions

Length of motorcycle	2151 mm
Height of motorcycle	1177 mm, in DIN normal-load position; with mirrors
Width of motorcycle	870 mm, across mirrors
Front-seat height	830 mm, at unladen weight



## Weights

Unladen weight	213 kg, DIN unladen weight, ready for road 90 % load of fuel, without optional extras
permitted gross weight	410 kg
maximum payload (without optional extras)	197 kg



## Service

BMW Motorrad service .....	122
BMW Motorrad service quality .....	122
BMW Motorrad Service Card: on-the-spot breakdown assistance .....	123
BMW Motorrad service network .....	123
Maintenance work .....	123
Maintenance schedules .....	124
Confirmation of maintenance work .....	125
Confirmation of service .....	130

## BMW Motorrad service

Advanced technology requires specially adapted methods of maintenance and repair.



If maintenance and repair work is performed inexpertly, it could result in consequential damage and thus constitute a safety risk.

BMW Motorrad recommends you to have all the associated work on your motorcycle carried out by a specialist workshop, preferably an authorised BMW Motorrad dealer. ◀

Your authorised BMW Motorrad dealer can provide information on the specified Service, Inspection and Annual Inspection work needed. Have all maintenance and repair work carried out

confirmed in the "Service" chapter in this manual.

Authorised BMW Motorrad dealers are supplied with the latest technical information and have the necessary technical know-how. BMW Motorrad recommends that you contact your authorised BMW Motorrad dealer if you have questions regarding your motorcycle.

### BMW Motorrad service quality

Along with its reputation for engineering quality and high reliability, BMW Motorrad is a byword for excellent quality of service.

To ensure that your BMW is always in optimum condition, BMW Motorrad recommends that you have the maintenance work required for your motorcycle carried out reg-

ularly, preferably by your authorised BMW Motorrad dealer. For generous treatment of claims submitted after the warranty period has expired, evidence of regular maintenance is essential.

Certain signs of wear, moreover, may otherwise not be noticed until it is too late to put them right at moderate cost. Your authorised BMW Motorrad dealer's mechanics know every detail of your motorcycle and can take remedial action if necessary before minor faults develop into serious problems. By having the necessary repairs done properly and in good time, you save time and money in the long run.

## **BMW Motorrad Service Card: on-the-spot breakdown assistance**

In the event of a breakdown, the BMW Motorrad Service Card issued with each new BMW motorcycle enables you to access an extensive range of services such as breakdown assistance, motorcycle transportation etc. (details can differ from country to country). In the event of a breakdown, contact BMW Motorrad's Mobile Service. The specialists will provide the necessary advice and assistance.

You will find important country-specific contact addresses and the after-sales service organisation phone numbers in the "Service Kontakt / Service Contact"

brochures, along with information on Mobile Service and the dealership network.

## **BMW Motorrad service network**

BMW Motorrad has an extensive after-sales service network in place to look after you and your motorcycle in more than 100 countries. In Germany alone, you have the best possible access to approximately 200 authorised BMW Motorrad dealers.

All information concerning the international dealership network can be found in the brochures entitled "Service Contact Europe" and "Service Contact Africa, America, Asia, Australia, Oceania".

## **Maintenance work Intervals**

Some maintenance tasks have to be performed after a certain time, others depend on the distance covered by the motorcycle.

### **BMW Running-in Check**

The BMW running-in check has to be performed when the motorcycle has covered between 500 km and 1,200 km

### **BMW Annual Inspection**

Some maintenance work has to be carried out at least once a year. Other tasks depend on the distance the motorcycle has covered.

## **BMW Service**

After the first 10,000 km and every additional 20,000 km (30,000 km, 50,000 km, 70,000 km, etc.) if this distance is covered within a year.

## **BMW Inspection**

After the first 20,000 km and every additional 20,000 km (40,000 km, 60,000 km, 80,000 km, etc.) if this distance is covered within a year.

## **Maintenance schedules**

The maintenance schedule for your motorcycle depends on the equipment fitted, and on the motorcycle's age and the distance it has covered. Your authorised BMW Motorrad dealer will be happy to supply

a copy of the current maintenance schedule for your motorcycle on request.

## Confirmation of maintenance work

### **BMW Pre-delivery Check**

Carried out in accordance with manufacturer's instructions

\_\_\_\_\_  
Date, stamp, signature

### **BMW Running-in Check**

Carried out in accordance with manufacturer's instructions

Odometer reading \_\_\_\_\_

Brake fluid, new

\_\_\_\_\_  
Date, stamp, signature

**BMW Service**

- BMW Annual Inspection
- BMW Service
- BMW Inspection

Carried out in accordance with manufacturer's instructions

Odometer reading\_\_\_\_\_

- Brake fluid, new

\_\_\_\_\_  
Date, stamp, signature

**BMW Service**

- BMW Annual Inspection
- BMW Service
- BMW Inspection

Carried out in accordance with manufacturer's instructions

Odometer reading\_\_\_\_\_

- Brake fluid, new

\_\_\_\_\_  
Date, stamp, signature

**BMW Service**

- BMW Annual Inspection
- BMW Service
- BMW Inspection

Carried out in accordance with manufacturer's instructions

Odometer reading\_\_\_\_\_

- Brake fluid, new

\_\_\_\_\_  
Date, stamp, signature



### **BMW Service**

- BMW Annual Inspection
- BMW Service
- BMW Inspection

Carried out in accordance with manufacturer's instructions

Odometer reading\_\_\_\_\_

- Brake fluid, new

\_\_\_\_\_  
Date, stamp, signature

### **BMW Service**

- BMW Annual Inspection
- BMW Service
- BMW Inspection

Carried out in accordance with manufacturer's instructions

Odometer reading\_\_\_\_\_

- Brake fluid, new

\_\_\_\_\_  
Date, stamp, signature

### **BMW Service**

- BMW Annual Inspection
- BMW Service
- BMW Inspection

Carried out in accordance with manufacturer's instructions

Odometer reading\_\_\_\_\_

- Brake fluid, new

\_\_\_\_\_  
Date, stamp, signature

**BMW Service**

- BMW Annual Inspection
- BMW Service
- BMW Inspection

Carried out in accordance with manufacturer's instructions

Odometer reading\_\_\_\_\_

- Brake fluid, new

\_\_\_\_\_  
Date, stamp, signature

**BMW Service**

- BMW Annual Inspection
- BMW Service
- BMW Inspection

Carried out in accordance with manufacturer's instructions

Odometer reading\_\_\_\_\_

- Brake fluid, new

\_\_\_\_\_  
Date, stamp, signature

**BMW Service**

- BMW Annual Inspection
- BMW Service
- BMW Inspection

Carried out in accordance with manufacturer's instructions

Odometer reading\_\_\_\_\_

- Brake fluid, new

\_\_\_\_\_  
Date, stamp, signature

### **BMW Service**

- BMW Annual Inspection
- BMW Service
- BMW Inspection

Carried out in accordance with manufacturer's instructions

Odometer reading\_\_\_\_\_

- Brake fluid, new

\_\_\_\_\_  
Date, stamp, signature

### **BMW Service**

- BMW Annual Inspection
- BMW Service
- BMW Inspection

Carried out in accordance with manufacturer's instructions

Odometer reading\_\_\_\_\_

- Brake fluid, new

\_\_\_\_\_  
Date, stamp, signature

### **BMW Service**

- BMW Annual Inspection
- BMW Service
- BMW Inspection

Carried out in accordance with manufacturer's instructions

Odometer reading\_\_\_\_\_

- Brake fluid, new

\_\_\_\_\_  
Date, stamp, signature

## Confirmation of service

The table is intended as a record of maintenance, warranty and repair work, the installation of optional accessories and, if appropriate, special campaign (recall) work.

Item	Odometer reading	Date

Item	Odometer reading	Date

- A**  
Abbreviations and symbols, 6  
ABS  
  Pushbutton, 15  
  Warning light, 20  
Accessories  
  General instructions, 70  
Anti-theft alarm, 17
- B**  
Battery, 14  
  Charging battery when connected, 98  
  Charging battery when disconnected, 99  
  Installation, 100  
  Maintenance instructions, 97  
  Removal, 99  
  Warning, battery charge current, 25  
Beam throw  
  Adjusting, 11
- Brake fluid  
  checking fluid level, front brakes, 78  
  Checking fluid level, rear brakes, 79  
  Fluid reservoir, rear, 13  
  Front fluid reservoir, 13  
Brake lever  
  Adjusting handbrake lever, 40  
Brake pads  
  checking front, 77  
  Checking rear, 78  
  Running in, 61  
Brakes  
  Checking operation, 76  
  Safety instructions, 63  
  Technical data, 115  
Bulbs  
  General instructions, 89  
  High-beam headlight, 18  
  Low-beam headlight, 18  
  Parking light, 18  
  Replacing front turn indicator bulb, 94  
  Replacing high-beam headlight bulb, 90  
  Replacing low-beam headlight bulb, 90  
  Replacing parking-light bulb, 92  
  Replacing rear turn indicator bulb, 95  
  Technical data, 117  
  Warning, bulb failure, 26
- C**  
Care, 101  
Checklist, 58  
Cleaning, 101  
Clock, 20  
  Adjusting, 17, 37  
Clutch  
  Adjusting clutch lever, 39  
  Checking operation, 80  
  Fluid reservoir, 11  
  Technical data, 112  
Confirmation of maintenance work, 125  
Currency, 7

## D

- Dimensions
  - Technical data, 118

## E

- Electrics
  - Technical data, 116
- Emergency off switch (kill switch), 16, 38
- Engine
  - Starting, 58
  - Technical data, 110
  - Temperature gauge, 20
  - Warning, engine electronics, 24
- Engine oil
  - Checking level, 74
  - Filler neck, 11
  - Technical data, 111
  - Temperature gauge, 20
  - Topping up, 76
  - Warning, engine oil pressure, 25
- Equipment, 7

## EWS

- Function description, 33
- Protection against theft, 33
- Warning, 24

## F

- Final drive
  - Technical data, 113
- Frame
  - Technical data, 118
- Front seat
  - Installation, 44
  - Removal, 44
- Front-wheel stand, 87
- Fuel
  - Filler neck, 13
  - refuelling, 62
  - technical data, 4, 110
  - Warning, fuel down to reserve, 24
- Fuses, 116

## G

- Gear indicator, 20
- Grip heating, 16, 39

## H

- Handlebar fittings
  - General view, left side, 15
  - General view, right side, 16
- Hazard warning flashers, 15
  - Switching off, 35
  - Switching on, 34
- Headlight
  - Adjusting headlight beam throw, 42
  - Adjustment for driving on left/driving on right, 41
- Headlight flasher, 15
- High-beam headlight, 15, 18
  - Telltale light, 20
- Horn, 15

## I

- Idle
  - Telltale light, 20
- Ignition
  - Switching off, 32
  - Switching on, 32
- Immobiliser
  - Warning, 24

- Instrument cluster
  - Overview, 17
  - Sensor for lighting, 17

**J**

- Jump start, 96

**K**

- Keys, 32
  - Replacement and extra keys, 34

**L**

- Laying up, 104
- Lights
  - Adjusting headlight beam throw, 42
  - Switching off parking lights, 41
  - Switching on high-beam headlight, 41
  - Switching on low-beam headlight, 40
  - Switching on parking lights, 41

- Switching on side lights, 40
- Low-beam headlight, 18

**M**

- Maintenance
  - General instructions, 74
  - Intervals, 123
- Multifunction display, 17

**P**

- Parking, 61
- Parking light, 18
- Power socket, 13, 70
- Pre-ride check, 59

**R**

- Rear seat
  - Installation, 45
  - Releasing, 14
  - Removal, 44
- Rear wheel stand, 88
- Refuelling, 62
- Residual range, 36
- Restoring to use, 105
- Rev. counter, 17

- Running gear
  - Setting length, 53
  - Technical data, 113
- Running in, 60

**S**

- Safety instructions, 56
  - Brakes, 63
    - correct loading, 56
- Seat lock, 11
- Service, 122
- Service Card, 123
- Side stand
  - Placing motorcycle on side stand, 61
  - Removing motorcycle from side stand, 62
  - starting the engine, 58
- Spark plugs
  - technical data, 117
- Speedometer, 17
- Spring preload
  - Adjusting, 47



Spring preload, front  
  Adjusting, 49  
  Setting for sport suspension, 47

Spring preload, rear  
  Adjusting, 47  
  Setting for sport suspension, 50  
  Setting with sport suspension, 11  
  Setting with standard suspension, 11

Starter, 16

Starting, 58

Steering lock, 33

Suspension damping, front  
  Adjusting, 50  
  Setting with sport suspension, 11

Suspension damping, rear  
  Adjusting, 11, 48  
  Setting for sport suspension, 51, 52  
  Setting with sport suspension, 13

## T

Technical data  
  Brakes, 115  
  Bulbs, 117  
  Clutch, 112  
  Dimensions, 118  
  Electrics, 116  
  Engine, 110  
  Engine oil, 111  
  Final drive, 113  
  Frame, 118  
  fuel, 4, 110  
  Running gear, 113  
  spark plugs, 117  
  Standards, 7  
  Transmission, 112  
  Weights, 119  
  Wheels and tyres, 115

Telltale lights, 17  
  Overview, 20

Toolkit, 14  
  Overview, 74

Torques, 109

Transmission  
  Starting engine, 58  
  Technical data, 112

Tripmaster  
  Operation, 35  
  Resetting tripmeter, 36  
  Residual range, 36  
  Scale range, 20  
  Selecting readings, 35

Troubleshooting chart, 108

Turn indicators  
  Left, 15, 42  
  Right, 16, 43  
  Switching off, 16, 43  
  Telltale light, 20

Tyres  
  Air pressure, 4, 116  
  Air-pressures table, 14  
  Approved tyres, 81  
  checking tread depth, 81  
  checking tyre pressures, 53  
  Running in, 61  
  Technical data, 115

**V**

## Vehicle

- Care, 101
- Cleaning, 101
- General view, left side, 11
- General view, right side, 13
- Laying up, 104
- Parking, 61
- Restoring to use, 105

**W**

- Warning light, general, 20
- Warning lights, 17
  - Overview, 20
- Warning symbols
  - Scale range, 20
- Warnings
  - Mode of presentation, 21
- Warnings, overview, 22, 28
- Weights
  - Technical data, 119

## Wheels

- Installing front wheel, 84
- Installing rear wheel, 86
- Removing front wheel, 82
- Removing rear wheel, 86
- Technical data, 115

Details described or illustrated in this booklet may differ from the motorcycle's actual specification as purchased, the accessories fitted or the national-market specification. No claims will be entertained as a result of such discrepancies.

Dimensions, weights, fuel consumption and performance data are quoted to the customary tolerances.

The right to modify designs, equipment and accessories is reserved.

Errors and omissions excepted.

© 2006 BMW Motorrad

Not to be reproduced either wholly or in part without written permission from BMW

Motorrad, After Sales.

Printed in Germany.

Important data for refuelling.

<b>Fuel</b>	
Recommended fuel grade	Super Plus unleaded (98 RON / 88 MON)
Fuel grade, usable with power- and consumption-related restrictions	Super unleaded (95 RON / 85 MON)
Fuel capacity, usable	17 l
Fuel capacity, reserve	4 l
<b>Tyre pressures</b>	
Tyre pressure, front	2.2 bar, One-up, tyre cold 2.5 bar, Two-up and/or with luggage, tyre cold
Tyre pressure, rear	2.5 bar, One-up, tyre cold 2.9 bar, Two-up and/or with luggage, tyre cold

BMW recommends 

Order No. 01 41 7 699 281  
02.2006, 1st edition

