

Rider's Manual (US Model)

K 1200 R



BMW Motorrad



The Ultimate Riding
Machine

Motorcycle/Retailer Data

Motorcycle data

Model

Vehicle Identification Number

Color number

First registration

Registration number

Retailer Data

Contact in Service

Ms./Mr.

Phone number

Retailer's address/phone number
(company stamp)

Welcome to BMW

We congratulate you on your choice of a motorcycle from BMW and welcome you to the community of BMW riders.

Familiarize yourself with your new motorcycle so that you can ride it safely and confidently in all traffic situations. Please read this Rider's Manual carefully before starting to use your new BMW motorcycle. It contains important information on how to operate the controls and how to make the best possible use of all your BMW's technical features.

In addition, it contains information on maintenance and care to help you maintain your motorcycle's reliability and safety, as well as its value.

If you have questions concerning your motorcycle, your

authorized BMW Motorrad retailer will gladly provide advice and assistance.

We wish you many miles of safe and enjoyable riding

BMW Motorrad.

Table of Contents

You can also use the index at the end of this Rider's Manual to find a specific topic.

1 General instructions ... 5

Overview 6

Abbreviations and symbols 6

Equipment 7

Technical data 7

Currentness of this manual 7

2 Overviews 9

General view, left side ... 11

General view, right side 13

Underneath seat 15

Left handlebar fitting 16

Handlebar fitting, right ... 17

Instrument cluster 18

Headlight 19

3 Status indicators 21

Multifunction display 22

Warning and indicator lights 22

ABS warning light^{OE} 22

Function indicators 22

General warning indicators 23

Warning indicators of Tire Pressure Control

TPC^{OE} 30

ABS warning indicators^{OE} 35

4 Operation 39

Ignition switch and steering lock 40

Electronic immobilizer EWS 41

Hazard warning flashers 42

Odometer and tripmeters 43

Clock 45

Tire Pressure Control

TPC^{OE} 46

Onboard computer^{OE} 46

Emergency ON/OFF switch 50

Heated hand grips^{OE}..... 50

Clutch 51

Brakes 51

Lights 52

Headlight 53

Turn indicators 54

Seat 55

Helmet holder 56

Luggage loops 57

Mirrors 57

Spring preload 58

Shock absorbers 59

Electronic suspension adjustment ESA^{OE} 60

Tires 61

5 Riding	63	Brake fluid	89	9 Technical data	123
Safety instructions	64	Clutch	91	Troubleshooting	
Checklist	66	Tires	92	chart	124
Starting	66	Rims	92	Threaded fasteners	125
Running in	68	Wheels	93	Engine	126
Parking your		Front wheel stand	101	Riding specifications	129
motorcycle	69	Rear-wheel stand	102	Clutch	129
Refueling	71	Lights	104	Transmission	129
Tire Pressure Control		Jump-starting	111	Rear-wheel drive	131
TPC ^{OE}	72	Battery	112	Running gear	131
General brake system	72	8 Care	117	Brakes	132
Brake system with BMW		Care products	118	Wheels and tires	132
Motorrad Integral		Washing your		Electrical system	133
ABS ^{OE}	73	motorcycle	118	Frame	135
6 Accessories	77	Cleaning sensitive		Dimensions	135
General instructions	78	motorcycle parts	119	Weights	136
Onboard socket	78	Paint care	120	10 Service	137
Luggage	79	Protective wax		BMW Motorrad	
Case ^{OA}	79	coating	120	Service	138
7 Maintenance	83	Storing motorcycle	120	BMW Motorrad Service	
General instructions	84	Returning motorcycle to		Quality	138
Toolkit	84	use	120	BMW Motorcycle Service	
Engine oil	85			Card - breakdown	
General brake system	87			service on the road	139
Brake pads	87				

BMW Motorrad Service

Network.....	139
Maintenance work	139
Maintenance schedules	140
Confirmation of maintenance work	141
Confirmation of service	146

General instructions

Overview	6
Abbreviations and symbols	6
Equipment	7
Technical data	7
Currentness of this manual	7

Overview

Chapter 2 of this Rider's Manual will provide you with an initial overview of your motorcycle. All maintenance and repair work carried out on your motorcycle will be documented in Chapter 10. Proof of the maintenance work performed is a prerequisite for generous treatment of claims. Should you want to sell your BMW one day, please also remember to turn over the Rider's Manual to the new owner; it is an important part of your motorcycle.

Abbreviations and symbols



Indicates warnings you should always observe to ensure your own safety, the safety of others and to

protect your motorcycle from damage.



Special information on operating and inspecting your motorcycle as well as maintenance and adjustment procedures.



Indicates the end of a note.



Instruction to take action.



Results of an action.



Reference to a page with additional information.



Indicates the end of accessory or equipment-dependent information.



Tightening torque.



Technical data.



Optional equipment BMW equipment available only as a factory installed option.



Optional accessories BMW optional accessories can be purchased and installed at your authorized BMW Motorrad retailer.



Electronic immobilizer.



Electronic Suspension Adjustment Electronic suspension adjustment.



Anti-theft alarm.

ABS Anti-Lock Brake System.

TPC Tire Pressure Control.

Equipment

When you ordered your BMW motorcycle, you chose various items of custom equipment. This Rider's Manual describes optional equipment (OE) offered by BMW and selected optional accessories (OA). This explains why the manual may also contain descriptions of equipment which you have not ordered. Please note, too, that your motorcycle might not be exactly as illustrated in this manual on account of country-specific differences.

If your BMW is equipped with options or accessories not described in this Rider's Manual, then this equipment is

described in a separate operating manual.

Technical data

All dimensions, weights and performance specifications in the Rider's Manual refer to the standards of the Deutsche Institut für Normung e.V. (DIN) and comply with its tolerance specifications. Versions for individual countries may differ.

Currentness of this manual

The high safety and quality standards of BMW motorcycles are maintained by constant development work on designs, equipment and accessories. Because of this, your motorcycle may differ from the information supplied in the Rider's Manual. Nor can errors and omissions be

entirely ruled out. We hope you will appreciate that no claims can be entertained on the basis of the data, illustrations or descriptions in this manual.

Overviews

General view, left side	11
General view, right side	13
Underneath seat	15
Left handlebar fitting	16
Handlebar fitting, right	17
Instrument cluster	18
Headlight	19

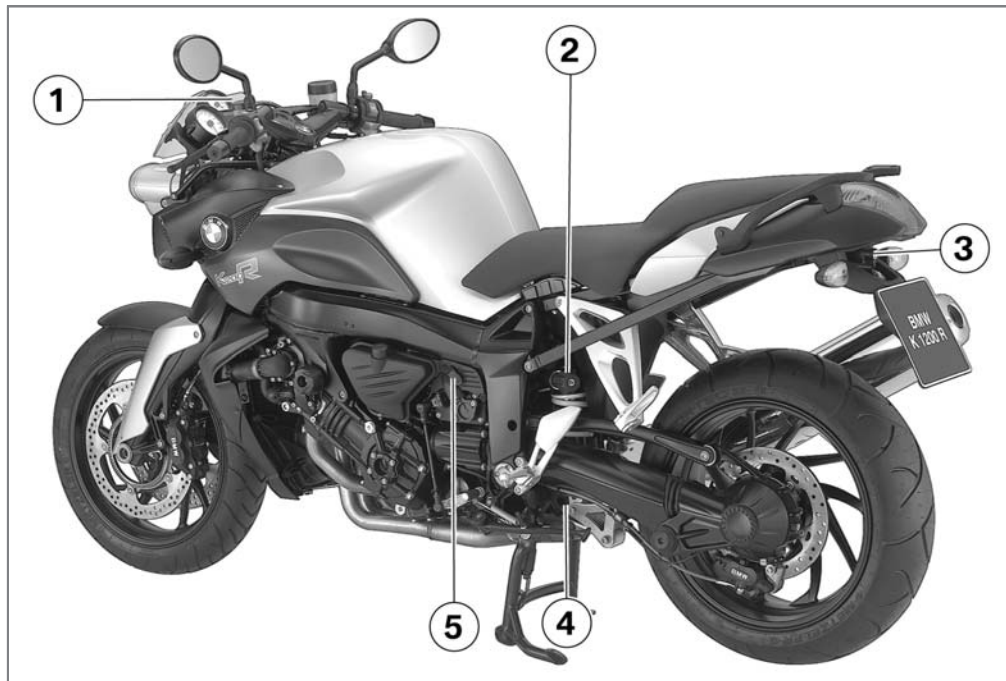

General view, left side

- 1 Clutch fluid reservoir
(➡ 91)
- 2 Adjuster, spring preload,
rear (➡ 58)
- 3 Seat lock, beneath tail
light (➡ 55)
- 4 Adjuster, rear shock ab-
sorber (➡ 59)
- 5 Onboard socket (➡ 78)

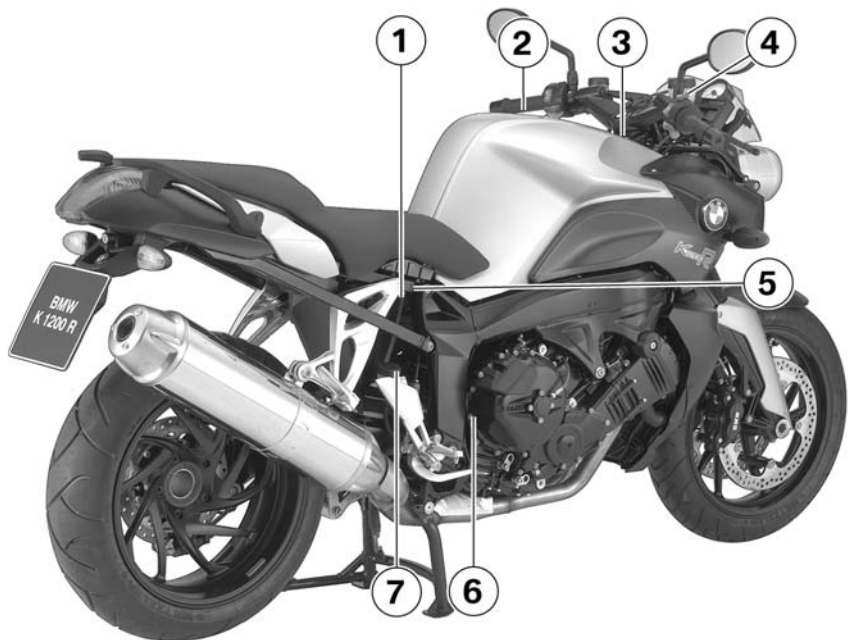

General view, right side

- 1 Display for engine oil level (➡ 85)
- 2 Fill location for fuel (➡ 71)
- 3 Battery compartment (➡ 115)
- 4 Brake-fluid reservoir, front (➡ 89)
- 5 Type plate
- 6 Vehicle Identification Number
- 7 Brake-fluid reservoir, rear (➡ 90)

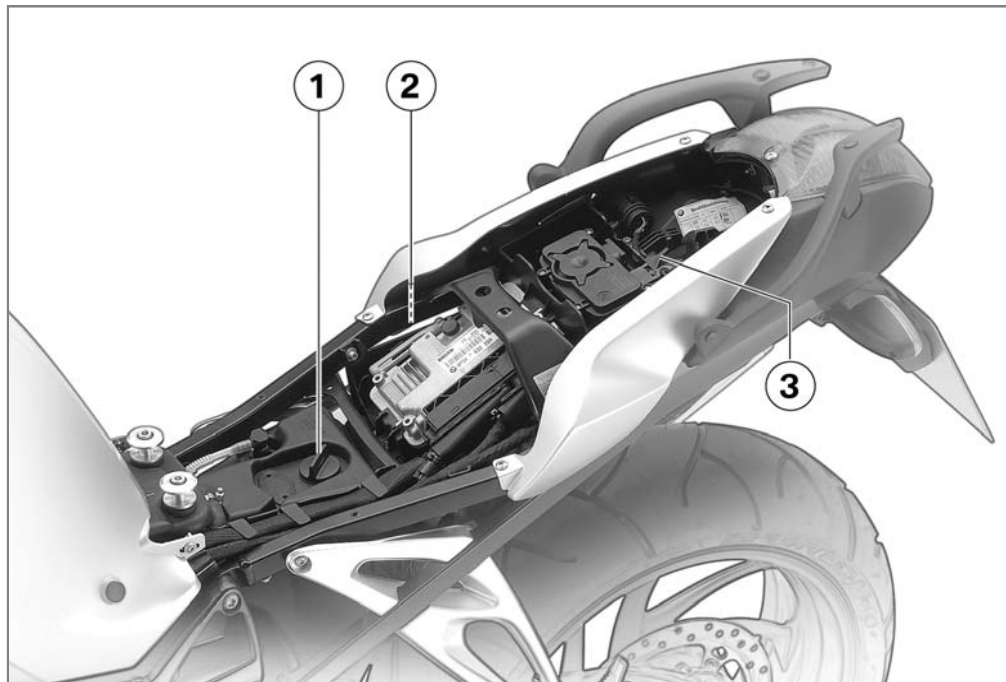

Underneath seat

- 1 Filler neck, engine oil (➡ 86)
- 2 Toolkit (➡ 84)
- 3 Helmet holder (➡ 56)

Left handlebar fitting

- 1 INFO button for odometer (➔ 43), INFO button for onboard computer^{OE} (➔ 46)
- 2 ESA button^{OE} (➔ 60)
- 3 Pushbutton, horn
- 4 Left turn indicator button (➔ 54), Hazard warning flashers button (➔ 42)
- 5 Switch, high-beam headlight and headlight flasher (➔ 52)



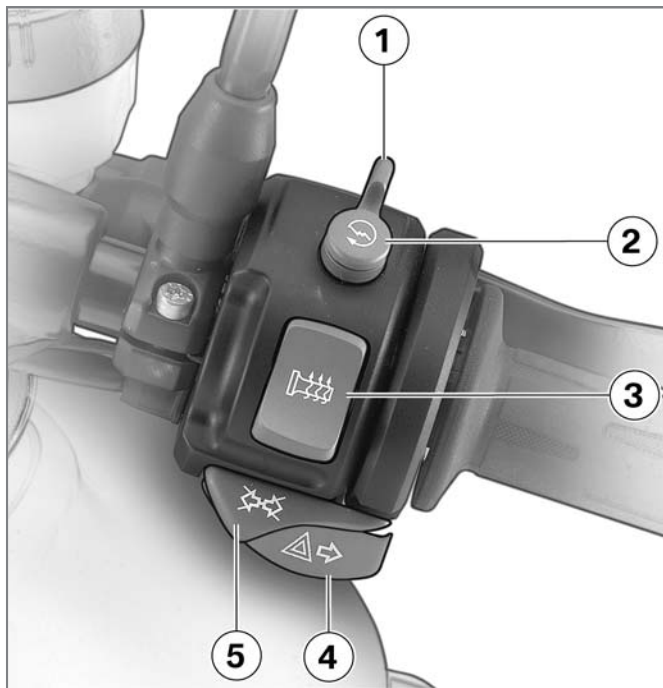

Handlebar fitting, right

- 1 Emergency ON/OFF switch (➔ 50)
- 2 Pushbutton, starter (➔ 66)
- 3 Heated hand grips switch^{OE} (➔ 50)
- 4 Right turn indicator button (➔ 54), Hazard warning flashers button (➔ 42)
- 5 Turn indicators off button (➔ 54), Hazard warning flashers off button (➔ 43)

Instrument cluster

- 1 Speedometer
- 2 Tachometer
- 3 Warning and indicator lights (➔ 22)
- 4 Multifunction display (➔ 22)
- 5 Anti-theft alarm indicator light (OE) and sensor for instrument lighting (➔ 22)
- 6 Control, odometer (➔ 43)

▶ The instrument-cluster lighting has automatic day and night switchover. ◀

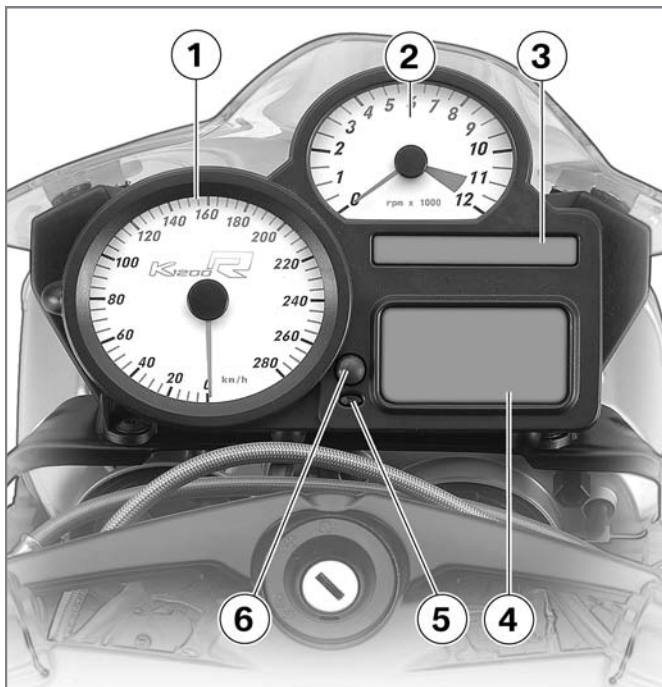

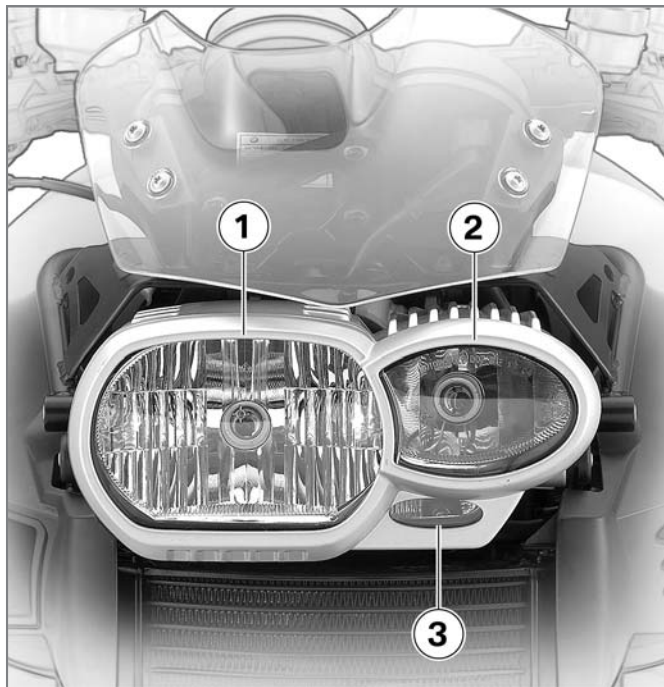

Headlight

- 1 High-beam headlights
- 2 Low-beam headlight
- 3 Side light

Status indicators

Multifunction display	22
Warning and indicator lights ...	22
ABS warning light ^{OE}	22
Function indicators	22
General warning indicators.....	23
Warning indicators of Tire Pressure Control TPC ^{OE}	30
ABS warning indicators ^{OE}	35

Multifunction display

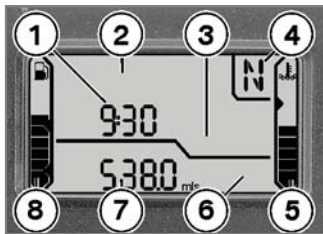

- 1 Clock (➡ 45), Area for TPC displays^{OE} (➡ 46), Area for oil level information^{OE} (➡ 49)
- 2 Area for warning symbols (➡ 23)
- 3 Area for onboard computer displays^{OE} (➡ 46)
- 4 Gear indicator (➡ 22)
- 5 Display, coolant temperature (➡ 23)
- 6 Area for ESA displays^{OE} (➡ 60)
- 7 Odometer display (➡ 43)
- 8 Fuel gauge (➡ 22)

Warning and indicator lights

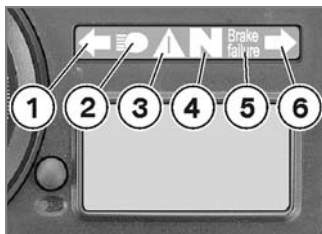

- 1 Indicator light, left turn indicator
- 2 Indicator light, high-beam headlight
- 3 Warning light, general
- 4 Indicator light, neutral
- 5 ABS warning light (OE)
- 6 Indicator light, right turn indicator

ABS warning light^{OE}

In some countries a different display of the ABS warning light is possible.



Possible country-dependent versions.

Function indicators

Fuel capacity



The horizontal bars under the gas pump symbol indicated the remaining fuel quantity.

Gear



Engaged gear is indicated.

If no gear is engaged, the gear indicator displays N and the 'neutral' indicator light lights up.

Coolant temperature



The lateral bars under the temperature symbol show the coolant temperature level.

General warning indicators













Display

General warnings are displayed by means of warning lights or texts and symbols in the multifunction display. In some cases, an additional general warning light lights up in red or yellow. If several warnings are active, all corresponding indicator lights and warning symbols are displayed. Warnings are shown alternately.

Overview of warning indicators



Display

Meaning

	Lights up in yellow		EWS ! warning appears.	Electronic immobilizer is active (➡ 26)
	Lights up in yellow		Warning FUEL ! flashes	Fuel down to reserve (➡ 26)
	Lights up in red		Temperature display flashes	Coolant temperature too high (➡ 26)
	Lights up in yellow		Appears	Engine electronics (➡ 27)
	Flashes in red		Appears	Engine oil pressure insufficient (➡ 27)
			Displayed with CHECK OIL warning	Engine oil level too low (➡ 28)
	Lights up in red		Appears	Battery charge current insufficient (➡ 28)
	Lights up in yellow		LAMP R ! warning appears.	Rear bulb defective (➡ 29)
			LAMP F ! warning appears.	Front bulb defective (➡ 29)

Display

Meaning

	Lights up in yellow	LAMPS ! warning appears.	Bulbs defective (➡ 29)	
			Appears	Ice warning (➡ 29)
		DWAL0 ! warning appears	Anti-theft alarm battery (OE) weak (➡ 30)	
	Lights up in yellow	DWA ! warning appears.	Anti-theft alarm battery (OE) dead (➡ 30)	

Electronic immobilizer is active

 General warning light lights up in yellow.

EWS ! warning appears.

The key being used is not authorized for starting, or communication between the key and engine electronics is disrupted.

- Remove other ignition keys located on the ignition key.
- Use the reserve key.
- Have the defective key replaced, preferably by an authorized BMW Motorrad retailer.

Fuel down to reserve

 General warning light lights up in yellow.

Warning FUEL ! flashes.

 A fuel shortage can lead to misfiring and to the engine dying unexpectedly. Misfiring can damage the catalytic converter, and the engine dying unexpected can lead to accidents.

Do not drive until the fuel tank is completely empty. ◀

 The probable operating range is indicated. ◀

At the most, the fuel tank still contains the reserve fuel quantity.

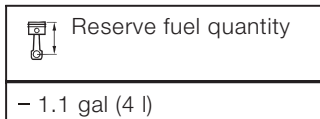

- Refueling (➡ 71)

Coolant temperature too high

 General warning light lights up in red.

 Temperature display flashes.

 Continued driving with an overheated engine can result in engine damage. Be sure to observe the measures listed below. ◀

The coolant temperature is too high.

- If possible, continue driving in the part-load range to cool down the engine.
- In traffic jams, switch off the engine, but keep the ignition switched on so that the radiator fan continues to operate.
- Should the coolant temperature frequently be too high, have the fault recti-

fied as quickly as possible by a specialized workshop, preferably an authorized BMW Motorrad retailer.

Engine electronics



General warning light lights up in yellow.



Engine electronics symbol appears.



The engine is in the emergency operating mode. Only reduced engine performance may be available, which can lead to danger driving situations, especially during passing maneuvers.

Adapt your driving style to the possibly reduced engine performance. ◀

The engine-electronics control unit has diagnosed a fault. In exceptional cases, the engine stops and can no longer

be started. Otherwise, the engine runs in the emergency operating mode.

- Continued driving is possible, however the accustomed engine performance may not be available.
- Have the malfunction corrected as soon as possible by a specialized workshop, preferably an authorized BMW Motorrad retailer.

Engine oil pressure insufficient



General warning light flashes in red.



Engine oil pressure symbol appears.

The oil pressure in the lubricating oil circuit is too low. If the warning light lights up, stop immediately and switch off the engine.



The warning on insufficient engine oil pressure is no substitute for the function of an oil-level indicator. The correct engine oil level can only be checked on the oil level indicator. ◀

The cause of the warning on insufficient engine oil pressure can be an insufficient engine oil level.

- Checking engine oil level (➔ 85)

If oil level is too low:

- Topping up engine oil (➔ 86)

If the warning on insufficient engine oil pressure appears despite a correct engine oil level:



In addition to an insufficient engine oil level, other problems in the engine can lead to the warning on insufficient engine oil pressure.

Continuing to ride in these cases can cause engine damage.

If this warning appears, do not continue to ride even though the engine oil level might be correct. ◀

- Do not continue driving.
- Have the malfunction corrected as soon as possible by a specialized workshop, preferably an authorized BMW Motorrad retailer.

Engine oil level too low



Oil level symbol is displayed with CHECK OIL warning.

The electronic oil level sensor has detected a low engine oil level.

The exact engine oil level can only be determined by checking the oil level indicator. During the next refueling stop:

- Checking engine oil level (➡ 85)

If oil level is too low:

- Topping up engine oil (➡ 86)

If "Check oil level" appears in the display, although a correct oil level has been measured with the oil level indicator, the oil level sensor may be defective.

- Contact a specialized workshop, preferably an authorized BMW Motorrad retailer.

Battery charge current insufficient



General warning light lights up in red.



Battery charge current symbol appears.



A discharged battery can result in the engine cutting out unexpectedly, causing a hazardous situation. Have faults eliminated as soon as possible. ◀



If the battery is no longer charged, continued driving can lead to deep discharging, and therefore to the destruction of the battery. If possible, do not continue driving. ◀

The battery is not being charged.

- Continued driving is possible until the battery is discharged. However, the engine can die suddenly and the battery can be exhaustively discharged and therefore destroyed.
- Have the malfunction corrected as soon as possible by a specialized workshop,

preferably an authorized BMW Motorrad retailer.

Rear bulb defective

 General warning light lights up in yellow.

LAMPR! warning appears.

 A defective bulb places your safety at risk because it is easier for other users to oversee you and your motorcycle.

Replace defective bulbs as soon as possible; always carry a complete set of spare bulbs if possible.◀

Rear light or brake light bulb defective.

- Replacing brake and tail light bulb (⇒ 108)

Front bulb defective

LAMPF! warning appears.

 A defective bulb places your safety at risk because it is easier for other users to oversee you and your motorcycle.

Replace defective bulbs as soon as possible; always carry a complete set of spare bulbs if possible.◀

Low-beam headlight, high-beam headlight, parking light or turn signal bulb defective.

- Replacing low-beam and high-beam bulb (⇒ 104)
- Replacing parking light bulb (⇒ 106)
- Replacing front and rear turn indicator bulbs (⇒ 109)

Bulbs defective

 General warning light lights up in yellow.

LAMPS! warning appears.

 A defective bulb places your safety at risk because it is easier for other users to oversee you and your motorcycle.

Replace defective bulbs as soon as possible; always carry a complete set of spare bulbs if possible.◀

A combination of several bulb defects is present.

- See the fault descriptions above.

Ice warning

 Ice warning symbol is displayed.

The air temperature measured at the motorcycle is lower than 37 °F (3 °C).

 The ice warning does not mean that there is no risk of black ice forming at measured temperatures above 3 °C.

Always take extra care and think well ahead when temperatures are low; remember that the danger of black ice is particularly high on bridges and where the road is in the shade. ◀

- Think well ahead when driving.

Anti-theft alarm battery (OE) weak

DWALO! warning appears.

▶ This error message is only displayed for a short time following the pre-ride check. ◀

The anti-theft alarm battery no longer has its full capacity. The operation of the anti-theft alarm is only ensured for a limited time with the motorcycle battery disconnected.

- Contact a specialized workshop, preferably an autho-

alized BMW Motorrad retailer.

Anti-theft alarm battery (OE) dead

⚠ General warning light lights up in yellow.

DWA! warning appears.

The anti-theft alarm battery has no capacity. The operation of the anti-theft alarm is no longer ensured with the motorcycle battery disconnected.

- Contact a specialized workshop, preferably an authorized BMW Motorrad retailer.

Warning indicators of Tire Pressure Control TPC^{OE}

Display of TPC warning indicators







In the display area of the clock or the onboard computer, the air pressure of the front wheel **1** and the rear wheel **2** are displayed with the text TPC. The critical air pressure flashes. If the critical value is at the limit of the permissible tolerance, the general warning light also lights up in yellow. If

the determined tire pressure is outside the permissible tolerance, the general warning light flashes in red.

Overview of warning indicators

Display

Display		Meaning
	Lights up in yellow	The critical air pressure flashes
	Flashes in red	The critical air pressure flashes
	-- or - - - -	Transmission error (➡ 33)
	Lights up in yellow	Is displayed with -- or - - - -
	Lights up in yellow	Is displayed with TPC! note

Meaning

Tire pressure in limit area of permissible tolerance (➡ 33)

Tire pressure outside permissible tolerance (➡ 33)

Transmission error (➡ 33)

Sensor defective or system fault (➡ 34)

Battery of tire pressure sensor weak (➡ 34)

Tire pressure in limit area of permissible tolerance



General warning light lights up in yellow.



The critical air pressure flashes.

The measured tire pressure is in the limit area of the permissible tolerance.

- Correct tire pressure in accordance with instructions on back of cover of Rider's Manual.



The pressure values on the back of the cover refer to a tire air temperature of 68 °F (20 °C). To also adapt the air pressure at other tire temperatures, proceed as follows:

Calculate the difference between the nominal value according to the Rider's Manual and the value determine by the TPC system. Change the

air pressure in the tire by this difference using an air pressure tester at a filling station. ◀

Tire pressure outside permissible tolerance



General warning light flashes in red.



The critical air pressure flashes.

The measured tire pressure is outside the permissible tolerance.

- Check tire for damage and drivability.

Is it still possible to drive with tire:



Incorrect tire pressure result in poorer handling of the motorcycle.

Always adapt your driving style to the incorrect tire pressure. ◀

- Correct tire pressure at next opportunity.
- Have the tire checked for damage by a specialized workshop, preferably an authorized BMW Motorrad retailer.

If you are unsure about the drivability of the tire:

- Do not continue driving.
- Inform roadside service.
- Have the tire checked for damage by a specialized workshop, preferably an authorized BMW Motorrad retailer.

Transmission error

-- or - - - - .

The motorcycle's speed has not exceeded the threshold of approx. 20 mph (30 km/h). The TPC sensors do not transmit their signal until a speed above this threshold is reached (➡ 72).

- Watch TPC display at higher speed. A permanent fault has not occurred until the general warning light also lights up. In this case:
- Have the fault eliminated by a specialized workshop, preferably an authorized BMW Motorrad retailer.

There is a fault in the radio connection to the TPC sensors. Possible causes are radio systems in the surrounding area, which interfere with the connection between the TPC control unit and the sensors.

- Watch the TPC display in another environment. A permanent fault has not occurred until the general warning light also lights up. In this case:
- Have the fault eliminated by a specialized workshop,

preferably an authorized BMW Motorrad retailer.

Sensor defective or system fault



General warning light lights up in yellow.



Is displayed with -- or - - -.

Tires without installed TPC sensors are mounted.

- Retrofit wheel set with TPC sensors.

One or two TPC sensors have failed.

- Have the fault eliminated by a specialized workshop, preferably an authorized BMW Motorrad retailer.

A system fault has occurred.

- Have the fault eliminated by a specialized workshop, preferably an authorized BMW Motorrad retailer.

Battery of tire pressure sensor weak



General warning light lights up in yellow.



Is displayed with TPC! note.



This error message is only displayed for a short time following the pre-ride check. ◀

The battery of the tire pressure sensor no longer has its full capacity. The operation of the tire pressure control is only ensured for a limited time.

- Contact a specialized workshop, preferably an authorized BMW Motorrad retailer.

ABS warning indicators^{OE}

Display

 ABS warnings are indicated by the ABS warning light. The warning light can light up continuously or flash.

In some countries an alternative display of the ABS warning light is possible.

 Possible country-dependent versions.

Overview of warning indicators

Display



Flashes



Lights up

Meaning

Self-diagnosis not completed
(➡ 37)

ABS error (➡ 37)

Self-diagnosis not completed

 ABS warning light flashes.

The ABS function is not available, because the self-diagnosis has not been completed. To check the wheel sensors, the motorcycle must be driven a few yards.

- Ride off slowly. It must be noted that the ABS function is not available until the self-diagnosis has been completed.

ABS error

 ABS warning light lights up.

The ABS control unit has detected an error. The ABS function is not available.

- Continue driving is possible. It must be noted that the

ABS function is not available. Observe additional information on situations which can lead to an ABS error (➡ 76).

- Have the malfunction corrected as soon as possible by a specialized workshop, preferably an authorized BMW Motorrad retailer.

Operation

Ignition switch and steering lock.....	40	Seat	55
Electronic immobilizer EWS	41	Helmet holder	56
Hazard warning flashers	42	Luggage loops	57
Odometer and tripmeters	43	Mirrors	57
Clock	45	Spring preload	58
Tire Pressure Control TPC ^{OE} ...	46	Shock absorbers	59
Onboard computer ^{OE}	46	Electronic suspension adjustment ESA ^{OE}	60
Emergency ON/OFF switch	50	Tires	61
Heated hand grips ^{OE}	50		
Clutch	51		
Brakes	51		
Lights	52		
Headlight	53		
Turn indicators	54		

Ignition switch and steering lock

Keys

You receive one master key and one spare key. If a key is lost, please note the information on the electronic immobilizer (EWS) (➔ 41).

▶ Ignition key and steering lock, tank filler cap lock and seat lock are all operated with the same key. Cases with locks for the same key as the cases available as optional accessories can be ordered on request. ◀

Switching on ignition



- Turn the key to position **1**.
 - » Parking lights and all function circuits switched on.
 - » Engine can be started.
 - » Pre-ride check is performed. (➔ 67)

with OE BMW Motorrad Integral ABS:

- Turn the key to position **1**.
 - » In addition to the points named above, the ABS self-diagnosis is also carried out. (➔ 67)◀

Switching off ignition

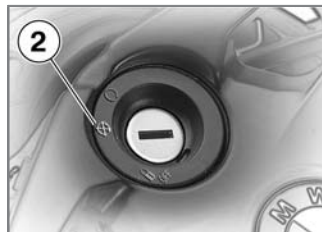

- Turn the key to position **2**.
 - » Light switched off.
 - » Handlebars not locked.
 - » Key can be removed.
 - » Electrically powered accessories remain operational for a limited period of time.
 - » Battery can be recharged via the onboard socket.

Locking handlebars

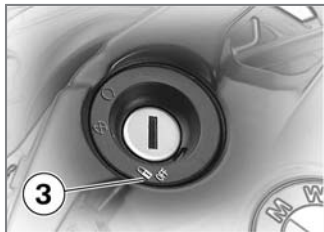

 When you prop the motorcycle on the side stand, the surface of the ground will determine whether it is better to turn the handlebars to the left or right. However, the motorcycle is more stable on a level surface with the handlebars turned to the left than with the handlebars turned to the right. On level ground, always turn the handlebars to the left to set the steering lock. ◀

- Turn handlebars to full left or right lock position.
- Turn the key to position **3** while moving the handlebars slightly.
 - » Ignition, lights and all function circuits switched off.
 - » Handlebars locked.
 - » Key can be removed.

Electronic immobilizer EWS

Theft protection

The electronic immobilizer helps protect your BMW motorcycle from theft, and this enhanced security is at your disposal without any need for you to set parameters or activate additional systems. The engine of a motorcycle fitted with this electronic immobilizer can be started only with the keys that belong to the motorcycle. You can al-

so have your authorized BMW Motorrad retailer disable particular keys, for example in the event that you lose your keys. The engine cannot be started with a key that has been barred.

Electronics in key

An electronic component is integrated into each of your keys. The motorcycle's electronics exchange certain continuously changing signals with the electronics in the key; these signals are specific to your motorcycle and they are transmitted via the ring antenna in the ignition lock. The ignition is not enabled for starting until the key has been recognized as "authorized" for your motorcycle.

 A spare key attached to the same ring as the ignition key used to start the

engine could "irritate" the electronics, in which case the enabling signal for starting is not issued. The warning EWS is shown in the multifunction display.

Always store the spare key separately from the ignition key. ◀

Replacement and extra keys

Replacement and spare keys are only available through an authorized BMW Motorrad retailer. The keys are part of an integrated security system, so the retailer is under an obligation to check the legitimacy of all applications for replacement/extra keys. If you want to have a lost key barred, you must bring along all other keys that belong to the motorcycle. A key that has been barred can subsequently be

cleared and reactivated for use.

Hazard warning flashers

Switching on hazard warning flashers

- Switch on ignition.

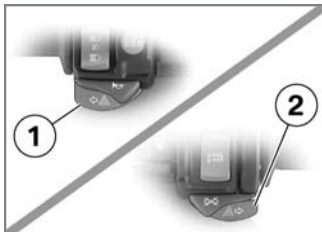

- Press button for left turn indicator **1** and right turn indicator **2** simultaneously.

▶ The hazard warning flashers place a strain on the battery. Do not use the hazard warning flashers

for longer than absolutely necessary. ◀

▶ If a turn indicator button is pressed with the ignition switched on, the flashing function replaces the emergency flashing function as long as the button is pressed. If the turn indicator button is released, the emergency flasher function becomes active again. ◀

- » Hazard warning flashers in operation.
- » Left/right turn indicator lights flash.
- Switch off ignition.
- » Hazard warning flashers continue to operate.
- » Left/right turn indicator lights off.

Switching off hazard warning flashers

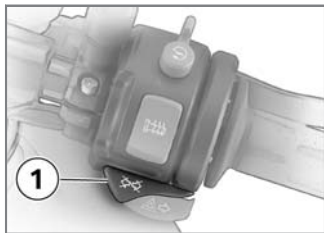

- Press turn-indicator cancel button **1**.
- » Hazard warning flashers are switched off.

Odometer and tripmeters

Operating odometer

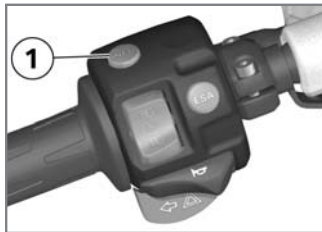

On motorcycles without an onboard computer and without TPC, the operation of the odometer described in the following can also be carried out alternatively with the INFO **1** button.

Selecting readings

- Switch on ignition.

▶ When you switch on the ignition, the information shown by the odometer when the ignition was switched off always reappears on the multifunction display. ◀

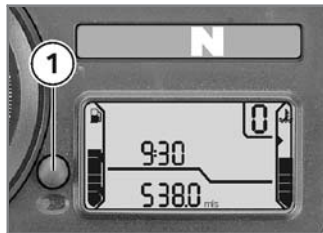

- Press button **1** once briefly.

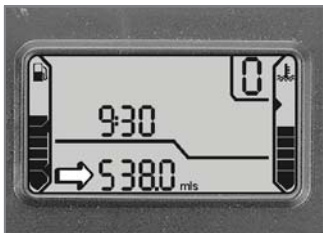

The odometer display field indicates the values below in the following order beginning with the current value:

- Total distance covered
- Tripmeter 1 (Trip I)
- Tripmeter 2 (Trip II)

Resetting tripmeter

- Switch on ignition.
- Select desired tripmeter.

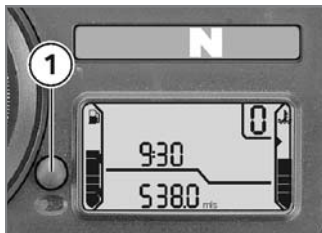

- Press and hold button **1** until display changes.
- » The tripmeter is reset to zero.

Residual range

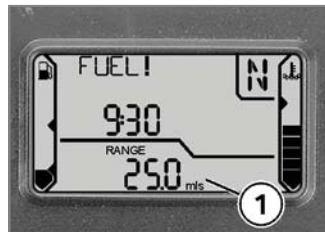

The operating range **1** indicates what distance can still be driven with the remaining fuel. It is only displayed on motorcycles without an on-board computer after the fuel reserve is reached. The calculation is carried out based on the average consumption and the fuel level.

When refueling, fuel is not registered until the quantity added is approx. one gallon (several liters).

▶ The determined residual range is an approximate reading. BMW Motorrad therefore recommends that you do not try to use the full remaining range before refueling. ◀

Clock

Setting clock

⚠ Attempting to set the clock while riding the motorcycle can lead to accidents.

Adjust the clock only when the motorcycle is stationary. ◀

- Switch on ignition.

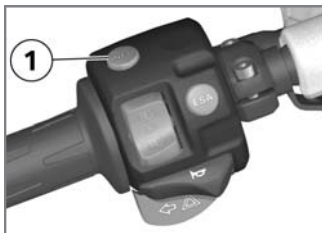

- Press INFO button **1** repeatedly until total mileage is shown.

with OE Onboard computer:



- Press INFO button **1** repeatedly until clock is shown. ◀

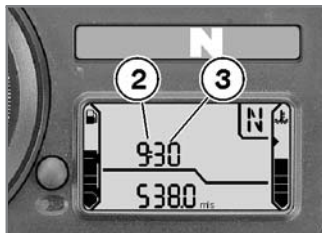

- Press and hold INFO button until display changes.
 - » Hours reading **2** starts to flash.
- Press INFO button.
 - » The hour increments by one each time you press the button.
- Press and hold INFO button until display changes.
 - » Minutes reading **3** starts to flash.
- Press INFO button.
 - » The minute increments by one each time you press the button.

- Press and hold INFO button until display changes.
- » The display stops flashing.
- » Clock setting ended.

Tire Pressure Control TPC^{OE}

Displaying tire pressures

- Switch on ignition.



- Repeatedly press INFO button **1** until the tire pressures appear in the display.



The tire pressures are shown alternately with the clock. The left-hand value indicates the air pressure of the front wheel, and the right-hand value the air pressure of the rear wheel. On motorcycles with an onboard computer, the tire pressures are displayed as an additional value of the onboard computer.

Onboard computer^{OE}

Selecting readings

- Switch on ignition.



- INFO button **1** once each time.

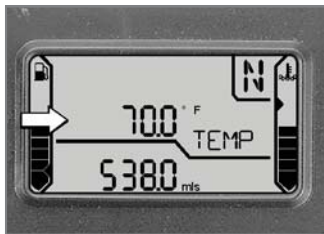

Ambient temperature

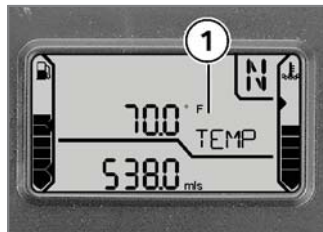

The display of the ambient temperature **1** is only active when the engine is running. Otherwise --- is shown.



An ice warning appears if the ambient-temperature reading drops below 37 °F (3 °C). The display automatically switches from any other mode to the temperature reading when the temperature drops below this threshold for the first time. The reading flashes until you

select some other display mode.

Calculation of average speed



The average speed **1** is calculated based on the elapsed time since the last "RESET". Times during which the engine was stopped are excluded from the calculation.

The onboard-computer display field indicates the values below in the following order beginning with the current value:

- Ambient temperature
- Average speed
- Average consumption
- Range
- Oil level
- Tire pressures (OE)

Resetting average speed



- Repeatedly press INFO button **1** until the average speed appears in the display.
- Press and hold INFO button until display changes ("RESET").
- » Display shows "--- mph".

Calculation of average consumption



The average consumption **1** is calculated by dividing the distance covered since the last "RESET" by the corresponding amount of fuel used.

Resetting average consumption



- Repeatedly press INFO button **1** until average consumption appears in display.
- Press and hold INFO button until display changes ("RESET").
- » Display shows "---. mpg".

Range

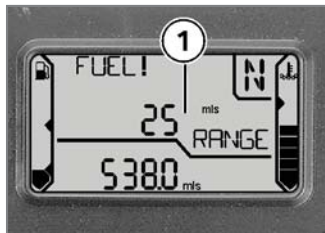

The operating description of the operating range (➔ 44) also applies to the range display. However, the range **1** can also be displayed before the fuel reserve is reached.

To calculate the range, a special average consumption is used, which does not always match the value that can be shown on the display.

▶ The determined range is an approximate reading. BMW Motorrad therefore recommends that you do not

try to use the full range before refueling.◀

Oil level



The oil level indicator **1** provides information on the oil level in the engine.

The conditions for the oil level check are as follows:

- Engine idling (for at least 10 seconds).
- Engine at operating temperature.
- Side-stand retracted.

The readings mean:

OK: Oil level is correct.

CHECK: Check oil level.

---: No measurement possible (above-mentioned conditions not met).

The most recently measured level is displayed for 5 sec. when you next switch on the ignition.

▶ If, despite a correct oil level on the oil sight glass, "Check oil level" continually appear on the display, the oil level sensor may be defective. In this case, please contact your authorized BMW Motorrad retailer.◀

Emergency ON/OFF switch

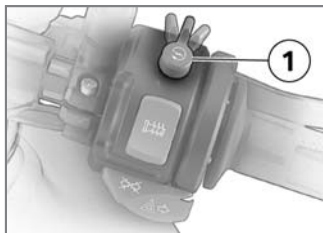

1 Emergency ON/OFF switch.

! Actuating the emergency ON/OFF switch while driving can cause the rear wheel to lock up, resulting in a fall.

Do not operate the emergency ON/OFF switch while riding. ◀

The engine can be easily and quickly switched off using the emergency ON/OFF switch.

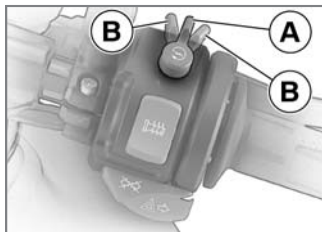

- A Operating position
- B Engine switched off.

▶ The engine can only be started in the operating position. ◀

Heated hand grips^{OE}

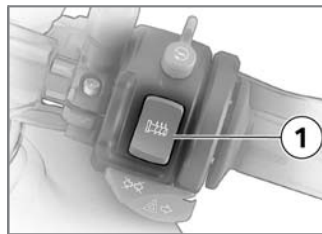

1 Heated hand grips switch

The handlebar grips can be heated at two different levels. The heated hand grips option can only be activated when the engine is running.

▶ The increase in power consumption caused by the heated hand grips can drain the battery if you are riding at low engine speeds. If the battery is inadequately charged, the heated hand

grips are switched off to ensure starting capability. ◀

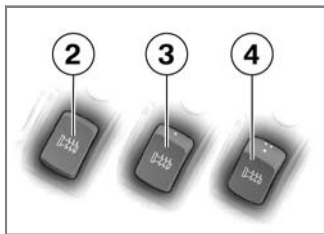

- 2 Heating function off.
- 3 50 % heat output (one dot visible).
- 4 100 % heat output (three dots visible).

Clutch

Adjusting clutch lever

! If the position of the clutch fluid reservoir is changed, air can enter the clutch system.
Do not reposition the handle-

bar controls on the handlebars or the handlebars in their mounts. ◀

! Adjusting the clutch lever while driving can lead to accidents.
Only adjust the clutch lever when the motorcycle is stationary. ◀

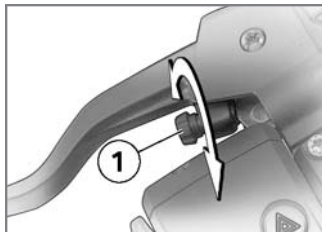

- Turn adjusting screw **1** clockwise.

▶ The adjusting screw has a limit position and can be turned more easily when you press the clutch lever forward. ◀

- » Distance between handlebar grip and clutch lever increases.
- Turn adjusting screw **1** counterclockwise.
- » Distance between handlebar grip and clutch lever decreases.

Brakes

Adjusting handbrake lever

! Changing the position of the brake-fluid reservoir can allow air to penetrate the brake system.

Do not reposition the handlebar controls on the handlebars or the handlebars in their mounts. ◀

! Adjusting the brake lever while driving can lead to accidents.
Only adjust the brake lever

when the motorcycle is stationary. ◀

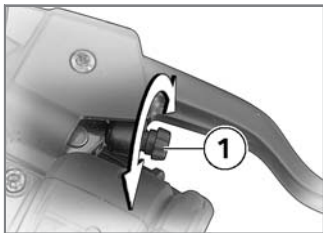

- Turn adjusting screw **1** clockwise.

▷ The adjusting screw has a limit position and can be turned more easily when you press the handbrake lever forward. ◀

- » Distance between handlebar grip and handbrake lever increases.
- Turn adjusting screw **1** counterclockwise.

» Distance between handlebar grip and handbrake lever decreases.

Lights

Switching on side lights

The side lights switch on automatically when the ignition is switched on.

▷ The side lights are a strain on the battery. Do not leave the ignition switched on longer than absolutely necessary. ◀

Switching on low-beam headlight

The low-beam headlight switches on automatically when you start the engine.

▷ With the engine switched off, you can switch on the lights by switching on the high-beam headlight with the

ignition switched on or by operating the headlight flasher. ◀

Switching on high-beam headlight



- Press top part of switch **1** for high-beam headlight.
- » High-beam headlight is switched on.
- Move switch **1** for high-beam headlight to center position.
- » High-beam headlight is switched off.

- Press bottom part of switch **1** for high-beam headlight.
- » High-beam headlight is switched on as long as switch is pressed (headlight flasher).

Switching on parking light

- Switch off ignition.

 You can switch on the parking lights only immediately after switching off the ignition.◀



- Press and hold left turn indicator switch **1** until parking light is switched on.

Switching off parking light

- Switch ignition on and then off again.
- » Parking light switched off.

Headlight

Adjusting headlight for RHD/LHD traffic

 Ordinary adhesive tape damages the plastic lens.

To prevent damage to the plastic lens, consult a specialized workshop, preferably an authorized BMW Motorrad retailer.◀

When riding in countries where traffic drives on the opposite side of the road to that in which the motorcycle was registered, the asymmetrical low headlight beam will dazzle oncoming traffic.

Have the headlight adjusted to the relevant conditions by a specialized workshop, preferably an authorized BMW Motorrad retailer.

Turn indicators

Switching on left-hand turn indicator

- Switch on ignition.



- Press left-hand turn indicator button **1**.

▶ After driving for approx. ten seconds or after covering a distance of approx. 650 ft (200 m), the turn indicators are automatically switched off.◀

- » Left-hand turn indicator is switched on.

- » Indicator light for left-hand turn indicator flashes.

Switching on right-hand turn indicator

- Switch on ignition.

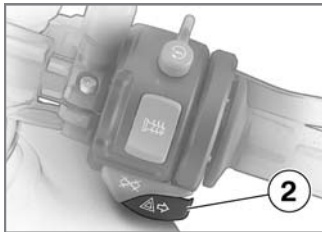

- Press right-hand turn indicator button **2**.

▶ After driving for approx. ten seconds or after covering a distance of approx. 650 ft (200 m), the turn indicators are automatically switched off.◀

- » Right-hand turn indicator is switched on.
- » Indicator light for right-hand turn indicator flashes.

Switching off turn indicator

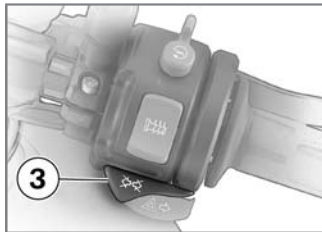

- Press turn-indicator cancel button **3**.

- » Turn indicator is switched off.
- » Turn indicator lights in indicator light panel are off.

Seat

Removing seat

- Make sure ground is level and firm and park the motorcycle.



- Turn key counterclockwise in seat lock.

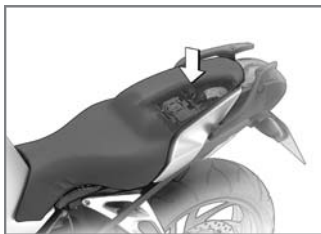

- Press down seat to assist.

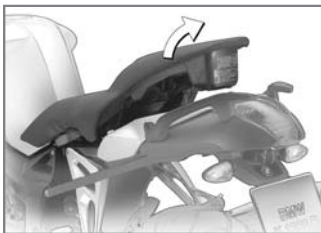

- Raise seat at rear.

! If seat is laid on a rough surface, seat edges can be damaged.

Lay seat on cover side on a

smooth, clean surface, e.g. on tank. ◀

- Release key and pull seat out of holder toward rear.

Installing seat



! If too much pressure is applied in the forward direction, there is a danger that the motorcycle will be pushed off its stand.

Make sure that the motorcycle is steady on its stand. ◀

- Slide seat forward into holders **1**.

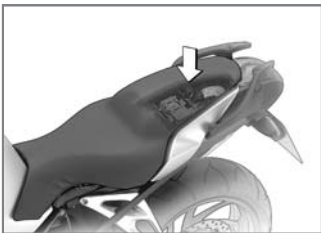

- Firmly press down seat over locking device.
- » Seat audibly engages.

Helmet holder

Helmet holder under seat

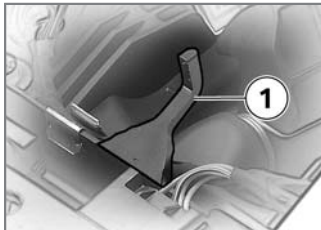

The helmet holder **1** is located under the seat.

A motorcycle helmet with chin strap can be attached to the helmet holder. If cases are mounted or if the chin strap is too short, a steel cable can be used to secure the helmet.

Using helmet holder

- Make sure ground is level and firm and park the motorcycle.

- Removing seat (➔ 55)

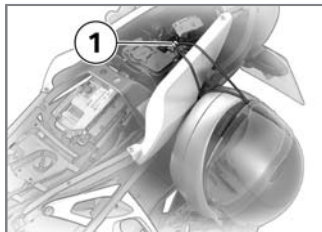

! The helmet catch can scratch the paneling. When hooking on the helmet, watch the position of the helmet lock.◀

! On the right-hand side of the motorcycle, the helmet could be damaged by heat from the end muffler. Only attach the helmet to the left-hand side of the motorcycle.◀

- Secure helmet on helmet holder **1** using steel cable

available as an optional accessory.

Luggage loops

Luggage loops under seat

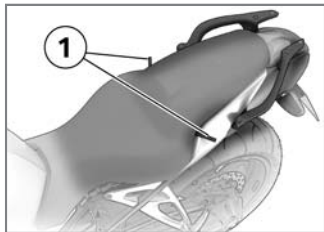

The loops **1** for attaching luggage straps are located on the underside of the seat.

Use luggage straps

- Make sure ground is level and firm and park the motorcycle.
- Removing seat (➡ 55)

- Turn over seat.

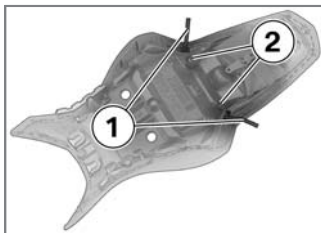

- Pull loops **1** out of retaining brackets **2**.
» Luggage straps can be hooked into loops.

Mirrors

Adjusting mirrors



- Move the mirrors into the desired position by pressing lightly on one of the corners.

Adjusting mirror arm



- Slide up protective cap over threaded fastener on mirror arm.
- Loosen union nut **1**.
- Turn mirror arm into desired position.
- Retighten union nut.



Mirror on clamping piece

– 13 lb/ft (18 Nm)

- Slide protective cap over screw fitting.

Spring preload

Spring preload and weight

The spring preload must be adapted to the load of the motorcycle. Increase spring preload when the motorcycle is heavily loaded and reduce spring preload accordingly when the motorcycle is lightly loaded.

Adjusting spring preload for rear wheel

 Your motorcycle's handling will suffer if you do not match the spring-preload and damping-characteristic settings.

Adjust the damping characteristic to suit the spring preload. ◀



Adjusting the spring preload while the motorcycle is being ridden can lead to accidents.

Adjust the spring preload only when the motorcycle is stationary. ◀

- Make sure ground is level and firm and park the motorcycle.

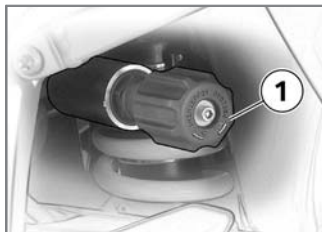

- To increase spring preload, turn handwheel **1** in direction of arrow HIGH.

- To decrease spring preload, turn handwheel **1** in direction of arrow LOW.

 One click corresponds to a half turn of the handwheel. The range of adjustment comprises 15 turns. ◀

 Spring-preload basic setting

- Turn handwheel as far as possible in direction of arrow LOW, then turn 15 clicks in direction of arrow HIGH (Full tank of gas, with rider 187 lbs (85 kg))

Shock absorbers

Damping and spring preload

The damping must be adapted to the spring preload. An increase in spring preload requires firmer damping, a reduction in spring preload requires softer damping.

Adjusting rear shock absorber

 Your motorcycle's handling will suffer if you do not match the spring-preload and damping-characteristic settings.

Adjust the damping characteristic to suit the spring preload. ◀

- Make sure ground is level and firm and park the motorcycle.

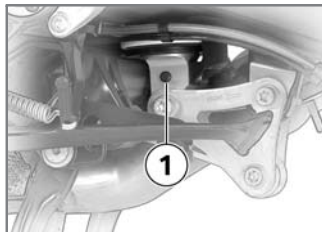

- Adjust rear shock absorber, using a screwdriver to turn adjusting screw **1**.



- To increase damping, turn adjusting screw in direction of arrow H.

- To decrease damping, turn adjusting screw in direction of arrow S.

▶ The range of adjustment comprises three and a half turns of the adjusting screw. ◀



Rear-wheel damping basic setting

- Turn adjusting screw as far as possible in direction of arrow H, then turn one and one-half turn in direction of arrow S (Solo mode with one person 187 lbs (85 kg))

Electronic suspension adjustment ESA^{OE}

Settings

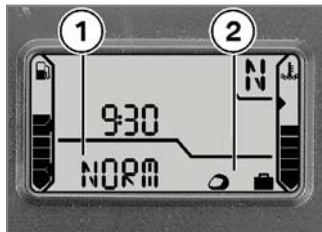

Using the electronic suspension adjustment ESA you can conveniently adjust your motorcycle to various driving conditions. Three spring preloads can be combined with three damping settings to optimally adapt the motorcycle to the load and the road surface. The damping setting is displayed in the multifunction display

in the area **1**, and the spring preload in the area **2**. The odometer display is hidden for the duration of the ESA display.

Calling up settings

- Switch on ignition.



- Press button **1**.
 - » The current setting is displayed.
 - » Display goes out automatically after a few seconds.

Adjusting damping

- Switch on ignition.

 The damping cannot be adjusted while the motorcycle is being ridden. ◀



- Press button **1**.
 - » Current setting is displayed.
- Press button **1** once briefly. Starting from the current state, the display is in the following order:
 - COMF comfortable damping
 - NORM normal damping
 - SPORT sporty damping

» If button **1** is not pressed for a longer time, damping is set as indicated. During setting procedure, display flashes.

Adjusting spring preload

- Start engine.

 The spring preload cannot be adjusted while the motorcycle is being ridden. ◀



- Press button **1**.
 - » Current setting is displayed.

- Press and hold button **1** until display changes each time.

Starting from the current state, the display is in the following order:



One-up



One-up with luggage



Two-up (with luggage)

- If button **1** is not pressed for a longer time, spring preload is set as indicated. During setting procedure, display flashes.

Tires

Checking tire pressures



Incorrect tire pressures result in poorer handling of the motorcycle and can lead to accidents.

Ensure proper tire pressure.◀



At high road speeds, tire valves have a tendency to open as a result of centrifugal force.

To avoid a sudden loss of tire pressure, use a metal valve cap with rubber sealing ring on the rear wheel and tighten it securely.◀



Incorrect tire pressure reduces the life of the tires.

Ensure proper tire pressure.◀

- Check correct tire pressure using following data.



Front tire pressure

– 36.3 psi (2.5 bar) (Single rider, with cold tire)

– 36.3 psi (2.5 bar) (Driver with passenger and/or load, with cold tire)



Rear tire pressure

– 42.1 psi (2.9 bar) (Single rider, with cold tire)

– 42.1 psi (2.9 bar) (Driver with passenger and/or load, with cold tire)

In case of insufficient tire pressure:

- Correct air pressure.

Riding

Safety instructions	64
Checklist	66
Starting	66
Running in	68
Parking your motorcycle	69
Refueling	71
Tire Pressure Control TPC ^{OE} ...	72
General brake system	72
Brake system with BMW Motorrad Integral ABS ^{OE}	73

Safety instructions

Rider's equipment

Do not ride without the correct clothing. Always wear:

- Helmet
- Rider's suit
- Gloves
- Boots

This applies even to short journeys, and to every season of the year. Your authorized BMW Motorrad retailer will be glad to advise you and has the correct clothing for every purpose.

Speed

If you ride at high speed, always bear in mind that various boundary conditions can adversely affect the handling of your motorcycle:

- Settings of the spring-strut and shock absorber system
- Imbalanced load
- Loose clothing
- Insufficient tire pressure
- Poor tire tread
- Etc.

Correct loading



Overloading and uneven loading can diminish the riding stability of the motorcycle.

Do not exceed the gross weight limit and observe the loading information. ◀

Alcohol and drugs



Even small amounts of alcohol or drugs will adversely affect your perception and your ability to assess situations and make decisions, and slow down your reflexes.

Medication can exacerbate these effects.

Do not ride your motorcycle after consuming alcohol, drugs and/or medication. ◀

Risk of poisoning

Exhaust fumes contain carbon monoxide, which is colorless and odorless but highly toxic.



Inhaling exhaust fumes therefore represents a health hazard and can even cause loss of consciousness with fatal consequences. Do not inhale exhaust fumes. Do not run the engine in closed rooms. ◀

High voltage



Touching live parts of the ignition system with the engine running can cause electric shock.

Do not touch parts of the ignition system when the engine is running. ◀

Catalytic converter

If misfiring causes unburned fuel to enter the catalytic converter, there is a danger of overheating and damage.

For this reason, observe the following points:

- Do not run the fuel tank dry
- Do not run the engine with the spark-plug cap removed
- Stop the engine immediately if it misfires
- Use unleaded fuel only
- Comply with all specified maintenance intervals.

 Unburned fuel will destroy the catalytic converter.

Note the points listed for protection of the catalytic converter. ◀

Risk of fire

Temperatures at the exhaust are high.

 Flammable materials (e.g. hay, leaves, grass, clothing and luggage, etc.) could ignite if allowed to come into contact with the hot exhaust pipe.

Make sure that no highly flammable materials can come in contact with the hot exhaust system. ◀

 Cooling would be inadequate if the engine were allowed to idle for a lengthy period with the motorcycle at a standstill: overheating would result.

In extreme cases, the motorcycle could catch fire. Do not allow the engine to idle unnecessarily. After starting, ride off immediately. ◀

Tampering with the control unit of the electronic engine-management system

 Modification of the engine-electronics control unit can lead to damage to the motorcycle, and therefore to accidents. Do not modify the engine-electronics control unit. ◀

 Tampering with control unit of electronic engine-management system can result in mechanical loads that the motorcycle's components are not designed to withstand. Damage caused in this way is not covered by the warranty.

Do not tamper with the control unit of the electronic engine-management system. ◀

Checklist

Use the following checklist to check important functions, settings and wear limits before you ride off.

- Brakes
- Front and rear brake fluid levels
- Clutch
- Clutch fluid level
- Shock absorber setting and spring preload
- Tread depth and tire pressure
- Firm seating of cases and luggage

At regular intervals:

- Engine oil level (every time you refuel)
- Brake pad wear (during every third stop for refueling)

Starting

Side stand

You cannot start the motorcycle with the side stand extended and a gear engaged. The engine will switch itself off if you start it with the transmission in neutral and then engage a gear before retracting the side stand.

Transmission

You can start the engine when the transmission is in neutral or if you pull the clutch with a gear engaged. Do not engage the clutch until after switching on the ignition, as otherwise the engine cannot be started. When the transmission is in neutral, the green neutral indicator light is on and the gear indicator in the multifunction display shows N.

Starting engine

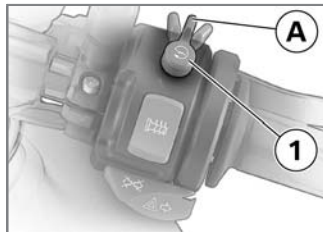

- Emergency ON/OFF switch **1** in operating position **A**.
- Switch on ignition.
 - » Pre-ride check is performed. (➡ 67)

with OE BMW Motorrad Integral ABS:

- Switch on ignition.
 - » Pre-ride check is performed. (➡ 67)
 - » ABS self-diagnosis is performed. (➡ 67)<1

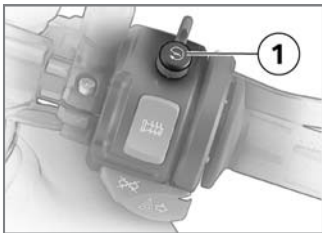

- Press starter button **1**.

▶ At extremely low temperatures it may be necessary to operate the throttle twist grip during starting. At ambient temperatures below 32 °F (0 °C), actuate the clutch after switching on the ignition. ◀

▶ The start attempt is automatically interrupted if battery voltage is too low. Recharge the battery before you start the engine, or use jump leads and a donor battery to start. ◀

- » Engine starts.
- » Consult the troubleshooting chart if the engine refuses to start. (➡ 124)

Pre-ride check

After the ignition is switched on, the instrument cluster carries out a general warning light test. In the process, the warning lamp first lights up in red and then yellow to test its function. This test, called a "Pre-Ride Check", is indicated by the lettering CHECK! in the display. If the engine is started during the test, the test is canceled.

Phase 1

 General warning light lights up in red.

- CHECK! warning appears.

Phase 2

 General warning light lights up in yellow.

- CHECK! warning appears. If the general warning light is not shown:

 If the general warning light cannot be displayed, several malfunctions cannot be indicated.

Watch the display of the general warning light in red and yellow. ◀

- Have the malfunction corrected as soon as possible by a specialized workshop, preferably an authorized BMW Motorrad retailer.

ABS self-diagnosis^{OE}

The readiness for operation of the BMW Motorrad Integral ABS is checked by the self-diagnosis. Self-diagnosis is performed automatically when

you switch on the ignition. To check the wheel sensors, the motorcycle must drive faster than 3 mph (5 km/h).

Phase 1

- » Checking the diagnosable system components while stopped.

 ABS warning light flashes.

 Possible country-specific version of ABS warning light.

Phase 2

- » Checking the wheel sensors while starting off.

 ABS warning light flashes.

 Possible country-specific version of ABS warning light.

ABS self-diagnosis completed

- » The ABS warning light goes out.

If an ABS fault is indicated after the ABS self-diagnosis is completed:

- Continue driving is possible. It must be noted that neither the ABS nor the integral function is available.
- Have the malfunction corrected as soon as possible by a specialized workshop, preferably an authorized BMW Motorrad retailer.

Running in

The first 600 miles (1,000 km)

- While running in motorcycle, vary throttle opening and engine-speed range frequently.

- Try to do most of your riding during this initial period on twisting, fairly hilly roads, avoiding high-speed main roads and highways if possible.

 Exceeding the specified engine speeds while running in will lead to increased engine wear. Adhere to the specified engine run-in speeds.◀

- Do not exceed engine run-in speeds.

	Engine run-in speeds
– <7000 min ⁻¹	

- Do not accelerate at full throttle.
- Avoid low engine speeds at full load.

- After 300 - 750 miles (500 - 1,200 km), have the first inspection performed.

Brake pads

New brake pads must "bed down" and therefore do not achieve their optimum friction levels during the first 300 miles (500 km). This initial reduction in braking efficiency can be compensated for by exerting greater pressure on the levers.

-  New brake pads can extend stopping distance by a significant margin. Brake early. ◀

Tires

New tires have a smooth surface. This must be roughened by riding in a restrained manner at various heel angles until the tires are run in. This running in procedure is

essential if the tires are to achieve maximum grip.

-  New tires have not achieved their full adhesion yet. There is a danger of accidents when driving at extreme angles. Avoid extreme angles. ◀

Parking your motorcycle

Placing on side stand

-  If the ground is soft or uneven, there is no guarantee that the motorcycle will rest firmly on the stand. Always check that the ground under the stand is level and firm. ◀

- Switch off engine.
- Pull handbrake lever.
- Hold motorcycle upright and balanced.

- Use your left foot to extend side stand fully.

-  The side stand is designed to support only the weight of the motorcycle. Do not lean or sit on the motorcycle with the side stand extended. ◀

- Slowly lean the motorcycle to the side until its weight is taken by the stand and dismount to the left.

-  When you prop the motorcycle on the side stand, the surface of the ground will determine whether it is better to turn the handlebars to the left or right. However, the motorcycle is more stable on a level surface with the handlebars turned to the left than with the handlebars turned to the right. On level ground, always turn

the handlebars to the left to set the steering lock.◀

- Turn handlebars to full left or right lock position.
- Check that motorcycle is standing firmly.

 On a grade, the motorcycle should always face uphill; select 1st gear.◀

- Lock steering lock.

Remove from side stand

- Unlock steering lock.
- Grip handlebars with both hands from left.
- Pull handbrake lever.
- Swing your right leg over the seat and lift the motorcycle to the upright position.
- Hold motorcycle upright and balanced.

 An extended side stand can catch on the ground

when the motorcycle is moving and lead to a fall.

Retract the side stand before moving the vehicle.◀

- Sit on the motorcycle and use your left foot to retract the side stand.

Placing on center stand^{OA}

 If the ground is soft or uneven, there is no guarantee that the motorcycle will rest firmly on the stand. Always check that the ground under the stand is level and firm.◀

- Switch off engine.
- Dismount and keep left hand on left handlebar grip.
- With your right hand, grip rear grab handle or rear frame.
- Place right foot on extended arm of center stand, and

press stand down until its curved feet touch ground.

- Place full weight of body on center stand while pulling motorcycle toward rear.

 Excessive movements could result in the center stand retracting, and the motorcycle would topple as a result.

Do not sit on the motorcycle while it is resting on the center stand.◀

- Check that motorcycle is standing firmly.
- Lock steering lock.

Pushing off center stand^{OA}

- Unlock steering lock.
- Place left hand on left handlebar grip.
- With your right hand, grip rear grab handle or rear frame.

- Push motorcycle forward off center stand.
- Make sure that center stand is fully retracted.

Refueling

 Fuel is highly flammable. Fire at the fuel tank can result in fire and explosion. Do not smoke. Never bring a naked flame near the fuel tank. ◀

 Fuel expands when exposed to heat. When the tank is overfilled, fuel can escape and get onto the rear wheel. This results in a danger of falling. Do not fill the tank past the bottom edge of the filler neck. ◀

 Fuel attacks plastic surfaces, making them cloudy or unattractive.

Wipe off any fuel that gets onto plastic parts immediately. ◀

 Leaded fuel will destroy the catalytic converter.

Use only unleaded fuel. ◀

- Make sure ground is level and firm and park the motorcycle.

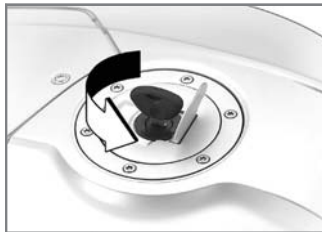

- Open protective cap.
- Open fuel tank cap with ignition key by turning counterclockwise.
- Refuel with the quality listed below at most until the low-

er edge of the filler neck is reached.

 Recommended fuel type

– 98 ROZ/RON (Super Plus unleaded)

– 95 ROZ/RON (Super unleaded (fuel type can be used with reduced performance and consumption))

 Usable fuel quantity

– 5 gal (19 l)

 Reserve fuel quantity

– 1.1 gal (4 l)

- Close fuel tank cap with firm pressure.
- Remove key and close protective cap.

Tire Pressure Control TPC^{OE}

Function

A sensor is located in each tire, which measures the air temperature and the air pressure inside the tire and sends these values to the control unit.

The sensors are equipped with a centrifugal controller, which does not enable the transmission of the measured values until a speed of approx. 20 mph (30 km/h) is reached. Before initial reception of the tire pressure, -- is shown in the display for each tire. The sensors continue to transmit the measured values for approx. 15 minutes after the motorcycle comes to a stop.

The control unit can manage four sensors, and as a result

two sets of wheels with TPC sensors can be driven. If a TPC control unit is installed, however the wheels have no sensors, then an error message is output.

Temperature compensation

The tire pressures are shown temperature-compensated in the multifunction display; they refer to a tire air temperature of 68 °F (20 °C). As the air-pressure testers at filling stations show a temperature-dependent tire pressure, they do not match the values indicated in the multifunction display in most cases.

Air pressure ranges

The TPC control unit distinguishes between three air pressure ranges matched to the motorcycle:

- Air pressure within the permissible tolerance.
- Air pressure at the limits of the permissible tolerance.
- Air pressure outside the permissible tolerance.

General brake system

Descending mountain passes



There is a danger of the brakes fading if you use only the rear brakes when descending mountain passes. Under extreme conditions, the brakes could overheat and suffer severe damage. Use both front and rear brakes, and make use of the engine's braking effect as well. ◀

Wet brakes

 After the motorcycle has been washed, ridden through water or ridden in the rain, the brake disks and pads might be wet and the brakes might not take effect immediately.

Brake early until the brakes are dry or braked until dry.◀

Salt on brakes

 The full braking effect can be delayed if the motorcycle is ridden on salt-covered roads and the brakes are not applied for some time. Brake early until the salt layer of the brake disks and brake pads has been braked off.◀

Oil or grease on brakes

 Oil and grease on the brake disks and pads considerably diminish braking efficiency.

Especially after repair and maintenance tasks, make sure that the brake discs and brake pads are free of oil and grease.◀

Dirt or mud on brakes

 When the motorcycle is ridden on loose surfaces or muddy roads, the brakes may fail to take effect immediately because of dirt or moisture on the disks or brake pads.

Brake early until the brakes are braked clean.◀

Brake system with BMW Motorrad Integral ABS^{OE}

Partially integral brake

Your motorcycle is equipped with a partially integral brake configuration. Both front and rear brakes are applied simultaneously when you pull the handbrake lever. The foot-brake lever acts only on the rear brake.

The BMW Motorrad Integral ABS adapts the braking force distribution between the front and rear wheel brake to the loading of the motorcycle during control.

 Spinning of the rear wheel with the front brake pulled (burn out) is made considerably more difficult by the integral function. The result may be

damage to the rear wheel brake and the clutch.

Avoid burn-outs. ◀

How does ABS work?

The maximum braking force that can be transferred to the road surface is partially dependent on the friction coefficient of the road surface. Gravel, ice, snow and wet roads offer a considerably poorer friction coefficient than a dry, clean asphalt surface. The poorer the friction coefficient of the road surface is, the longer the braking distance will be.

If the maximum transferrable braking force is exceeded when the driver increases the brake pressure, the wheels begin to block and driving stability is lost, and a fall can result. Before this situation occurs, ABS intervenes and

adjusts the brake pressure to the maximum transferrable braking force. This enables the wheels to continue to turn and maintains driving stability regardless of the road surface condition.

What happens when rough roads are encountered?

Bumpy or rough roads can briefly lead to a loss of contact between the tires and the road surface, until the transferrable braking force is reduced to zero. If braking is carried out in this situation, ABS must reduce the brake pressure to ensure driving stability when restoring contact to the road. At this point in time, the BMW Motorrad Integral ABS must assume extremely low friction coefficients (gravel, ice, snow)

so that the running wheels turn in every imaginable case and the driving stability is ensured. After detecting the actual conditions, the system adjusts the optimum brake pressure.

How is the BMW Motorrad Integral ABS noticeable to the driver?

If the ABS system must reduce the braking forces due to the conditions described above, then vibrations can be felt at the handbrake lever. If the handbrake lever is pulled, then braking pressure is built up at the rear wheel with the integral function. If the footbrake pedal is first actuated after this, the brake pressure already built up can be felt earlier than the counter-pressure, than when the footbrake pedal is

actuated before or together with the handbrake lever.

How is the shortest braking distance achieved?

The dynamic load distribution between the front and rear wheel changes during braking. The heavier you brake, the more the front wheel is loaded. The greater the wheel load, the more braking force can be transferred.

To achieve the shortest possible braking distance, the front brake must be applied quickly and with increasing force. This optimally utilizes the dynamic load increase on the front wheel. At the same time, the clutch should also be actuated. With the "forced braking" often practiced in which the brake pressure is generated as quickly as pos-

sible and with great force, the dynamic load distribution cannot follow the increased deceleration and the braking force cannot be completely transferred to the road surface. To prevent the front wheel from locking, the ABS system must intervene and reduce the brake pressure; the braking distance increases.

Rear wheel lift

Even during severe braking, a high level of tire grip can mean that the front wheel does not lock up until very late, if at all. Consequently, ABS does not intervene until very late, if at all. Under these circumstances the rear wheel can lift off the ground, and the outcome can be a highside situation in which the motorcycle can flip over.



Severe braking can cause the rear wheel to lift off the ground. When braking, bear in mind that the ABS control cannot be relied on in all circumstances to prevent the rear wheel from lifting off the ground. ◀

What are the design characteristics of the BMW Motorrad Integral ABS?

The BMW Motorrad Integral ABS ensures driving stability on any surface within the limits of driving physics. The system is not optimized for special requirements resulting under extreme weather conditions offroad or on the racetrack.

Special situations

To detect the tendency of the wheels to lock up, the speeds of the front and rear wheel are compared. If implausible values are detected over a longer period of time, the ABS function is deactivated for safety reasons and an ABS fault is indicated. The condition for a fault message is the completed self-diagnosis.

In addition to problems on the BMW Motorrad Integral ABS, unusual driving conditions can also lead to a fault message.

Unusual driving conditions:

- Heating up on the main or auxiliary stand at idle or with gear engaged.
- Rear wheel locked-up for a longer period of time by engine brake, e.g. when riding downhill offroad.

Should a fault message result due to one of the driving conditions described above, the ABS function can be reactivated by switching the ignition off and then on again.

How important is regular maintenance?



Any technical system is always only as good as its maintenance condition.

To ensure that the BMW Motorrad Integral ABS is in an optimally maintained condition, it is vital that the specified inspection intervals be complied with. ◀

Reserves for safety

But remember: the potentially shorter braking distances which BMW Motorrad Integral ABS permits must not be used as an excuse for careless riding. ABS is primarily

a means of ensuring a safety margin in genuine emergencies.

Take care when cornering. When you apply the brakes on a corner, the motorcycle's weight and momentum take over and even BMW Motorrad Integral ABS is unable to counteract their effects.

Accessories

General instructions	78
Onboard socket	78
Luggage	79
Case ^{OA}	79

General instructions

BMW Motorrad recommends the use of parts and accessories for your motorcycle that are approved by BMW for this purpose.

Your authorized BMW Motorrad retailer is the right place to go for genuine BMW parts and accessories, other BMW-approved products, and expert advice on their installation and use.

These parts and products have been tested by BMW for safety, function and suitability. BMW accepts product liability for these products.

Conversely, BMW is unable to accept any liability whatsoever for parts and accessories which it has not approved.



BMW Motorrad cannot examine or test each product of outside origin to

ensure that it can be used on or in connection with BMW motorcycles without constituting a safety hazard. Nor is this guarantee provided when the official approval of a specific country has been granted. Tests conducted by these instances cannot make provision for all operating conditions experienced by BMW motorcycles and, consequently, they are not sufficient in some circumstances. Use only parts and accessories approved by BMW for your motorcycle. ◀

Whenever you are planning modifications, comply with all the legal requirements. The motorcycle must not infringe on national road-vehicle construction and use regulations.

Onboard socket

Ratings

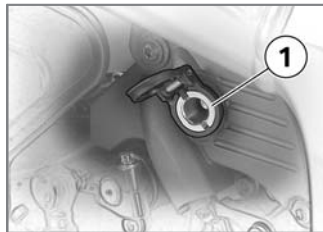

When the battery voltage is insufficient, and when the maximum loading capacity of the standard onboard socket **1** and the additional socket (OA) is exceeded, these sockets are automatically switched off.

Operating electrical accessories

You can start using electrical accessories only when the ignition is switched on. The accessory remains operational if the ignition is subsequently switched off. Approx. 15 minutes after switching off the ignition and/or during the restart operation, the onboard socket is switched off to take the load off the motorcycle electrical system.

Cable routing

The cables from the onboard socket to the auxiliary device must be routed in such a way that they:

- Do not impede the rider
- Do not restrict or obstruct the steering angle and handling characteristics
- Cannot be trapped



Improperly routed cables can impede the rider.

Route the cables as described above.◀

Luggage

Correct loading



Overloading and uneven loading can diminish the riding stability of the motorcycle.

Do not exceed the gross weight limit and observe the loading information.◀

When driving with loaded cases, a top speed of 112 mph (180 km/h) is recommended.

- Adjust setting of spring preload, damping characteristic and tire pressures to suit total weight.
- Ensure that case volumes on left and right are equal.

– Make sure that weight is uniformly distributed between right and left.

– Pack heavy items of luggage downwards and inwards.

– Max. load in each case (left and right): 18 lbs (8 kg).

– Max. load in tank rucksack 11 lbs (5 kg).

Case^{OA}

Release levers

There is a release lever on the left and right of each case lock.

The gray lever marked OPEN is used to open and close the cases.

The black lever marked RELEASE is used to remove and attach the cases.

Opening case



- Turn lock barrel in direction **OPEN**.

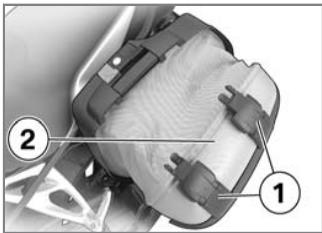

- Pull gray release lever (OPEN) upward.
- » Lock straps **1** open.

- Pull gray release lever (OPEN) upward again.
- Pull case lid **2** out of retainer.

Closing case

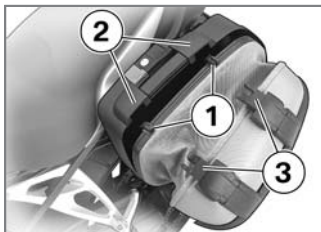

- Press catches **1** of case lid into the retainers **2**.
 - » The catches can be heard to lock into place.
- Press catches **3** of lock straps into retainers **2**.
 - » The catches can be heard to lock into place.
- Make sure catches are secure.

Adjusting case volume

- Close case lid.

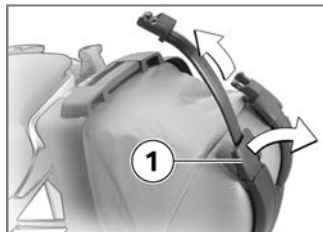

- Turn lock strap buckles **1** of lock straps outward.
- Pull out the lock straps upwards.
- » The maximum volume has been set.

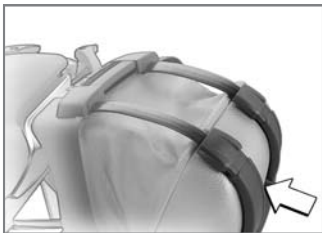

Removing case

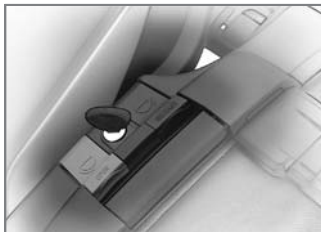

- Turn lock barrel in direction RELEASE.
- Pull black release lever (RELEASE) upward.

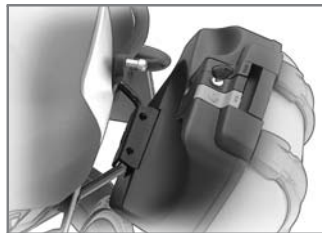

- Pull the case out of the upper mounting.
- Lift the case out of the lower mounting.

- Close the lock straps.
- Press the lock straps against the case body.
- » The case volume is adapted to the contents.

Mounting case

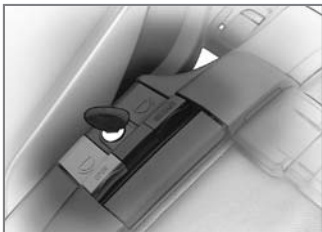

- Turn lock barrel in direction RELEASE.

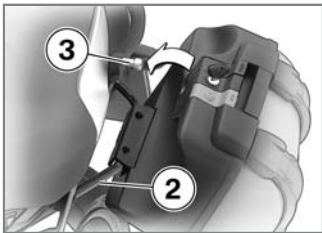

- Hook case into lower mounting **2**.

- Pull black release lever (RELEASE) upward.
- Press case into upper mounting **3**.
- Press black release lever (RELEASE) downward.
 - » Case is locked into place.
- Lock the case.
- Check secure locking.

Secure hold



If a case wobbles or is difficult to mount, it has to be adapted to the gap between the upper and lower mounting. To achieve this, the height of

the lower bracket on the case can be changed.

Adapting case

- Open case.

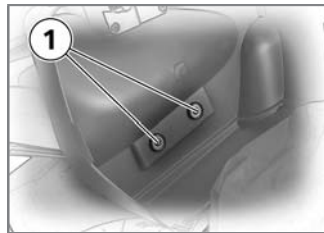

- Unfasten screws **1**.
- Adjust height of bracket.
- Tighten screws **1**.

Maintenance

General instructions	84
Toolkit	84
Engine oil	85
General brake system	87
Brake pads.....	87
Brake fluid	89
Clutch	91
Tires	92
Rims	92
Wheels	93
Front wheel stand	101
Rear-wheel stand	102
Lights	104
Jump-starting	111
Battery.....	112

General instructions

The 'Maintenance' chapter describes work involving the replacement of wear parts that can be performed with a minimum of effort.

If special tightening torques are to be taken into account for assembly, these are also listed.

If you are interested in information on additional work, we recommend the Repair Manual for your motorcycle on CD-ROM. This is available from your BMW Motorrad retailer.

Special tools and a thorough knowledge of motorcycles are required to carry out some of the work described here. If you are in doubt, consult a certified workshop, preferably your authorized BMW Motorrad retailer.

Toolkit

Standard onboard toolkit

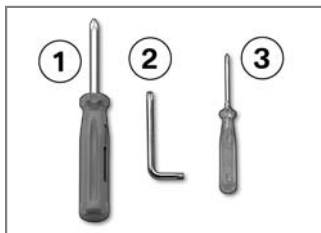

1 Screwdriver, reversible blade

- Removing and installing turn indicator glasses
- Disconnecting battery terminals

2 Torx wrench, T25

- Removing and installing body panels
- Removing and installing battery retaining strap

3 Screwdriver, small

- Removing and installing turn indicator glasses

Onboard-toolkit service set

Your BMW Motorrad retailer offers the onboard-toolkit service set for additional work. Information on conducting this work is provided in the Repair Manual on CD-ROM, which is also available from your BMW Motorrad retailer.

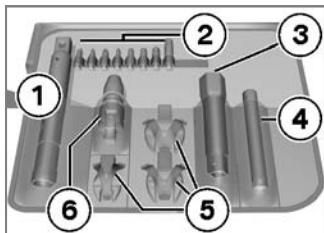

1 Pull-out tool holder

- Holding of all tools with adapter

2 1/4" bits

- 5x Torx
- 2x Phillips
- 1x Straight-blade

3 3/8" Allen key, 22 mm

- Removing and installing front wheel

4 Flashlight

- LED technology

5 Socket wrench

- 3x Open-ended wrench, various wrench sizes

6 Bit adapter

- Mounting for 1/4" bits
- 9x12 mm and 3/8" jointed adapter

Engine oil

Checking engine oil level

 The engine can seize if the oil level is low, and this can lead to accidents. Always make sure that the oil level is correct.◀

 After longer motorcycle immobilization periods, engine oil can collect in the oil pan; this must be pumped into the oil tank before the reading is taken. Here, the engine oil must be at operating temperature. Checking the oil level with the en-

gine cold or after a short trip leads to misinterpretations and therefore to incorrect oil fill quantities.

To ensure that the display of the engine oil level is correct, only check the oil level after a longer trip.◀

 The oil level varies with the temperature of the oil. The higher the temperature, the higher the oil level in the oil tank. Check the engine oil level immediately after a longer journey.◀

- Make sure the ground is level and firm and hold motorcycle at operating temperature vertically, with OA Center stand:
- Make sure ground is level and firm and place motorcycle at operating temperature on its center stand.◀

- Let the engine run in neutral for one minute.
- Switch off ignition.



- Read off the oil level from the display **1**.



Specified level of engine oil

– Between MIN and MAX marking

If oil level is below MIN mark:

- Top up engine oil.

If oil level is above MAX mark:

- Drain off engine oil.

Topping up engine oil

- Make sure ground is level and firm and park the motorcycle.

- Removing seat (➔ 55)



Both too little and too much engine oil can lead to engine damage. Always make sure that the oil level is correct. ◀

- Wipe the area around the filler neck clean.

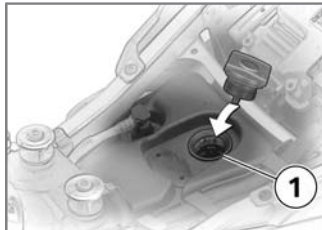

- Remove cap from oil fill location **1** by turning counter-clockwise.
- Add engine oil up to specified level.
- Install cap of oil fill location **1** by turning clockwise.

- Installing seat (➡ 55)

Draining engine oil

- Removing seat (➡ 55)

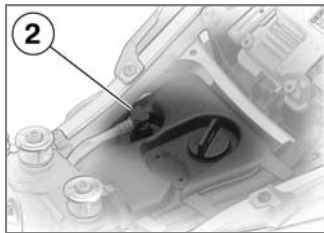

- Press retainer of clear hose **2** on left and right and pull out of oil tank upwards.
- Pull clear hose downward out of frame and drain engine oil into a suitable container until specified level is reached.
- Insert the clear hose in the oil tank and lock into place.

- Store or dispose of excess engine oil in line with sound environmental principles.
- Installing seat (➡ 55)

General brake system

Operating safety

A properly functioning brake system is a basic requirement for the road safety of your motorcycle.

Do not ride the motorcycle if you have any doubts about the dependability of the brake system.

In this case, have the brake system checked by a specialized workshop, preferably by an authorized BMW Motorrad retailer.

 Incorrect working practices endanger the reliability of the brakes.

Have all work on the brake system performed by a spe-

cialized workshop, preferably by an authorized BMW Motorrad retailer. ◀

Checking brake operation

- Pull handbrake lever.
- » Pressure point must be clearly perceptible.
- Press footbrake lever.
- » Pressure point must be clearly perceptible.

Brake pads

Checking front brake pad thickness

 Continuing to use brake pads beyond the minimum pad thickness leads to reduced braking power and under certain circumstances to brake damage.

In order to ensure the operating reliability of the brake system, make sure that the brake

pads are not worn beyond their minimum thickness. ◀

- Make sure ground is level and firm and park the motorcycle.



- Visually inspect left and right brake pads to ascertain their thickness.

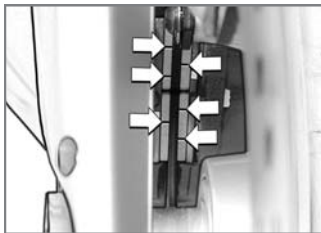

Front brake pad thickness

- The brake pads must have a clearly visible wear indicating mark.

If the wear indicating mark is no longer clearly visible:

- Have the brake pads replaced by a specialized workshop, preferably an authorized BMW Motorrad retailer.

Checking brake pad thickness at rear



Continuing to use brake pads beyond the minimum pad thickness leads to reduced braking power and under certain circumstances to brake damage.

In order to ensure the operating reliability of the brake system, make sure that the brake pads are not worn beyond their minimum thickness. ◀

- Make sure ground is level and firm and park the motorcycle.

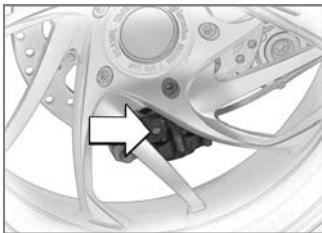

- Perform a visual inspection of the brake pad thickness from the right.



 Rear brake-pad material thickness

– Wear limit

 Rear brake-pad material thickness

– 0.04 in (1 mm) (Only friction material without carrier plate)

– Brake disk must not be visible through bore hole of inner brake pad.

If the brake disk is visible:

- Have the brake pads replaced by a specialized workshop, preferably an authorized BMW Motorrad retailer.

Brake fluid

Checking front brake fluid level

 A low fluid level in the brake reservoir can allow air to penetrate the brake system. This significantly reduces braking efficiency.

Check brake fluid level regularly. ◀

- Make sure the ground is level and firm and hold motorcycle vertically.
- Move handlebars into straight-ahead position with OA Center stand:
- Make sure ground is level and firm and place motorcycle on its center stand.
- Move handlebars into straight-ahead position. ◀



- Read off brake fluid level at front brake-fluid reservoir **1**.

▶ In the event of brake pad wear, the brake fluid level in the brake-fluid reservoir falls. ◀



Front brake fluid level

– Brake fluid DOT4

– The brake fluid level must not fall below the MIN mark. (Brake-fluid reservoir horizontal)

If the brake fluid level drops below the permissible level:

- Have the defect corrected as soon as possible by a specialized workshop, preferably an authorized BMW Motorrad retailer.

Checking rear brake fluid level

 A low fluid level in the brake reservoir can allow air to penetrate the brake system. This significantly reduces braking efficiency. Check brake fluid level regularly. ◀

- Make sure the ground is level and firm and hold motorcycle vertically with OA Center stand:
- Make sure ground is level and firm and place motorcycle on its center stand. ◀



- Read off brake fluid level at brake-fluid reservoir **1**.

▶ In the event of brake pad wear, the brake fluid level in the brake-fluid reservoir falls. ◀

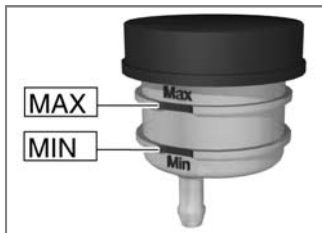

Rear brake fluid level

– Brake fluid DOT4

– The brake fluid level must not fall below the MIN mark. (Brake-fluid reservoir horizontal)

If the brake fluid level drops below the permissible level:

- Have the defect corrected as soon as possible by a specialized workshop, preferably an authorized BMW Motorrad retailer.

Clutch

Checking clutch operation

- Pull the clutch lever.
 - » Pressure point must be clearly perceptible.
- If no clear pressure point can be felt:

- Have the clutch checked by a specialized workshop, preferably an authorized BMW Motorrad retailer.

Checking clutch fluid level

- Make sure the ground is level and firm and hold motorcycle vertically.
 - Move handlebars into straight-ahead position.
- with OA Center stand:
- Make sure ground is level and firm and place motorcycle on its center stand.

- Move handlebars into straight-ahead position.◁



- Read off clutch fluid level at clutch fluid reservoir **1**.

▷ The fluid level in the clutch fluid reservoir rises due to clutch wear.◀



Clutch fluid level

– The clutch fluid level must not drop.

If the fluid level drops:



Unsuitable hydraulic fluids could cause damage to the clutch system.

No fluids may be poured in. ◀

- Have the defect corrected as soon as possible by a specialized workshop, preferably an authorized BMW Motorrad retailer.



The clutch system is filled with a special hydraulic fluid that does not require changing. ◀

Tires

Checking tire tread depth



The handling of your motorcycle can already change for the worse before the legally prescribed minimum tread depth is reached. Have tires replaced even before the minimum tread depth is reached. ◀

- Make sure ground is level and firm and park the motorcycle.
- Measure the tire tread depth in the main tread grooves with wear indicating marks.



Tires have wear indicators integrated into the main tread grooves. If the tire tread has worn down to the level of the marks, the tire is completely worn. The locations of the marks are indicated on the edge of the tire, e.g. by the letters TI, TWI or by an arrow. ◀

If the minimum tread depth is reached:

- Replace tire concerned.

Rims

Checking rims

- Make sure ground is level and firm and park the motorcycle.
- Visually inspect the rims for defects.
- Have damaged rims checked and, if necessary, replaced by a specialized workshop, preferably an

authorized BMW Motorrad retailer.

Wheels

Approved wheels and tires

For every size of tire, BMW Motorrad has tested certain makes and approved those it has found to be roadworthy. If you use wheels and tires that have not been approved, BMW Motorrad cannot assess their suitability or provide any guarantee as to their road safety.

Use only wheels and tires that BMW Motorrad has approved for your type of motorcycle. Extensive information is available at your authorized BMW Motorrad retailer or on the Internet at www.bmw-motorrad.com.

TPC sticker^{OE}

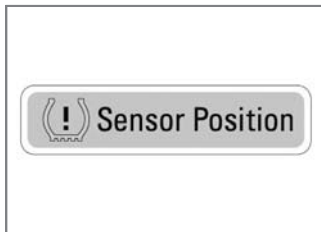

 The TPC sensors can be damaged by improper tire mounting. Inform the BMW Motorrad retailer or the specialized workshop that the wheel is equipped with a TPC sensor. ◀

On motorcycles equipped with TPC, a corresponding sticker is located on the wheel rim at the position of the TPC sensor. During a tire change it must be ensured that the TPC sensor is not

damaged. Inform the BMW Motorrad retailer or the specialized workshop of the TPC sensor.

Removing front wheel

- Place motorcycle on an auxiliary stand; BMW Motorrad recommends BMW Motorrad rear wheel stand.
- Installing rear-wheel stand (➔ 103) with OA Center stand:
- Make sure ground is level and firm and place motorcycle on its center stand. ◀

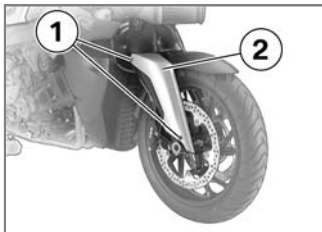

- Remove screws **1** on left and right.
- Remove trim pieces **2** on left and right.

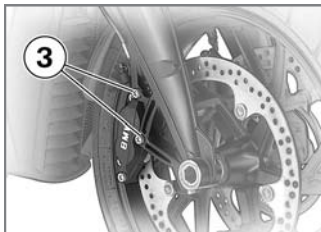

! Once the calipers have been removed, there is a risk of the brake pads being pressed together to the extent that they cannot be slipped back over the brake disk on reassembly. Do not operate the handbrake lever when the brake calipers have been removed. ◀

- Remove mounting bolts **3** of brake calipers on left and right.

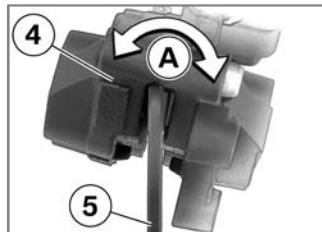

- Press brake pads in brake caliper **4** somewhat apart with rotary movements **A** against brake disks **5**.
- Mask off area of wheel rim that could be scratched in process of removing brake calipers.
- Carefully pull brake calipers back and out until clear of brake disks.

with OE BMW Motorrad Integral ABS:

- When pulling off left brake caliper, make sure that

ABS sensor cable is not damaged.◀

- Raise front of motorcycle until front wheel can rotate freely. To lift motorcycle, BMW Motorrad recommends using BMW Motorrad front wheel stand.
- Mounting front wheel stand (➔ 101)

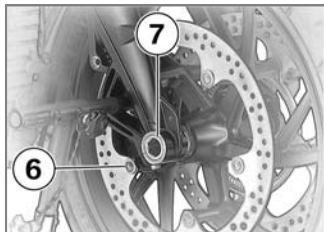

- Remove right-hand axle clamping screw **6**.

with OE BMW Motorrad Integral ABS:

! The left axle clamping screw fixes the threaded bush in place in the front suspension. A poorly aligned threaded bush results in incorrect spacing between the ABS sensor ring and the ABS sensor, and therefore to ABS malfunctions or destruction of the ABS sensor.

To ensure the proper alignment of the threaded bush, do not loosen or remove the left axle clamping screw.◀

- Remove right-hand axle clamping screw **6**.◀
- Remove quick-release axle **7**, holding wheel as you do so.
- Place the front wheel in the front wheel guide on the ground.

- Roll front wheel forward to remove.

with OE BMW Motorrad Integral ABS:

! The ABS sensor can be damaged when rolling out the front wheel. Watch the ABS sensor when rolling out the front wheel.◀

- Roll front wheel forward to remove.◀

Installing front wheel

! ABS malfunctions due to incorrect speed signals. There are differently segmented sensor wheels which may not be interchanged. Only install the correct sensor wheel for the corresponding construction status.◀

! Threaded fasteners not tightened to the specified torque can work loose or

their threads can suffer damage.

Always have the tightening torques checked by a specialized workshop, preferably an authorized BMW Motorrad retailer. ◀

! The front wheel must be installed right way round to rotate in the correct direction.

Observe the direction of rotation arrows on the tires or on the rim. ◀

• Roll the front wheel into the front wheel guide.
with OE BMW Motorrad Integral ABS:

! During the following work, parts of the front brake, in particular of the BMW Motorrad Integral ABS, can be damaged.

Take care not to damage the brake system, in particular the

ABS sensor with cable and the ABS sensor ring. ◀

! The ABS sensor can be damaged when rolling in the front wheel.

Watch the ABS sensor when rolling in the front wheel. ◀

• Roll the front wheel into the front wheel guide. ◀

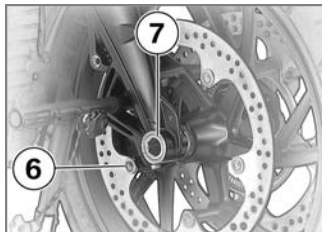

• Lift front wheel and install quick-release axle **7** with torque.



Quick-release axle in threaded bush

– 37 lb/ft (50 Nm)

• Tighten the right-hand axle clamping screw **6** with the appropriate torque.





Clamping screw on quick-release axle in wheel carrier

– 14 lb/ft (19 Nm)

• Remove front wheel stand.
• Ease brake calipers onto brake disks.

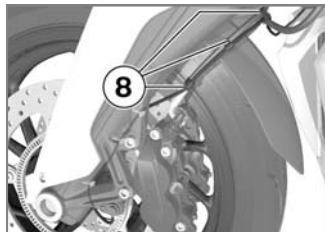
with OE BMW Motorrad
Integral ABS:



 The cable of the ABS sensor could chafe through if it comes into contact with the brake disk. Make sure that ABS sensor cable is routed correctly. ◀

- Carefully route ABS cable. When doing so, make sure ABS sensor cable is clipped into retaining clips **8**. ◀

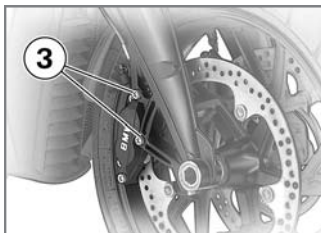

- Install mounting screws **3**.



Front brake caliper on
wheel carrier

– 22 lb/ft (30 Nm)

- Remove adhesive tape from wheel rim.

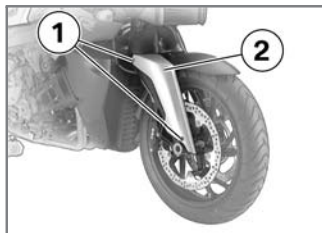

- Position trim pieces **2** on left and right.
- Install screws **1** on left and right.
- Press the handbrake lever firmly a number of times until the resistance point is noticeable.

Removing rear wheel

- Place motorcycle on an auxiliary stand; BMW Motorrad recommends BMW Motorrad rear wheel stand.
- Installing rear-wheel stand (➔ 103)

with OA Center stand:

- Make sure ground is level and firm and place motorcycle on its center stand.<

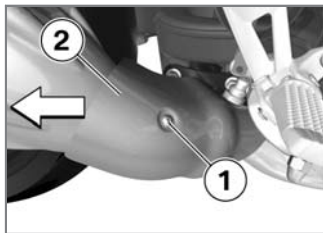

- Remove bolt **1** of muffler cover **2**.
- Pull cover towards rear.

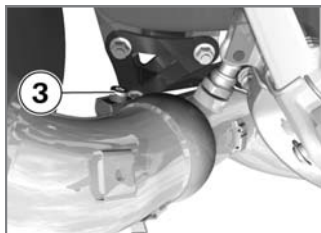

- Remove clamp **3** on muffler.
- Do not remove sealing grease from clamp.



- Remove bolt **4** of end muffler bracket on rear footrest.
- Turn end muffler out.

- Shift into first gear.



- Remove mounting bolts **5** of rear wheel, holding wheel as you do so.
- When using the BMW Motorrad rear wheel stand: remove the lock washer.
- Lower rear wheel onto ground.
- Roll the rear wheel out toward the rear.
- When using the BMW Motorrad rear wheel stand: re-mount the lock washer.

Installing rear wheel

 Threaded fasteners not tightened to the specified torque can work loose or their threads can suffer damage.

Always have the tightening torques checked by a specialized workshop, preferably an authorized BMW Motorrad retailer. ◀

- When using the BMW Motorrad rear wheel stand: remove the lock washer.
- Roll the rear wheel onto the rear wheel support.
- Place the rear wheel on the rear wheel support.
- When using the BMW Motorrad rear wheel stand: re-mount the lock washer.



- Mount wheel bolts **5** and tighten diagonally with appropriate tightening torque.



Rear wheel on wheel flange

– Tightening sequence:
Tighten diagonally

– 44 lb/ft (60 Nm)

- Turn the end muffler to its initial position.



- Install screw **4** for end muffler bracket in rear footrest, but do not tighten it at this point.

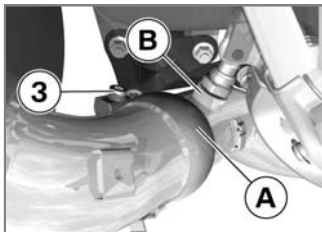

- Align clamp **3** on end muffler with marking **A** (arrow) on lambda probe **B**.
- Tighten clamp **3** on end muffler to appropriate torque.



Muffler on manifold

– 26 lb/ft (35 Nm)



! If the gap between the rear wheel and the end muffler is too small, the rear wheel can overheat. The gap between the rear wheel and the end muffler must be at least 10 mm. ◀

- Tighten screw **4** for bracket of end muffler on passenger footrest with torque.



Muffler on right passenger footrest

– 12 lb/ft (16 Nm)

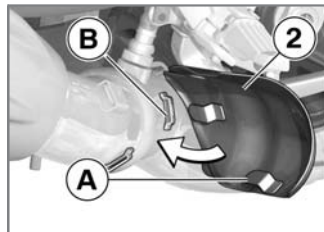

- Push muffler cover **2** with guides **A** into brackets **B**.

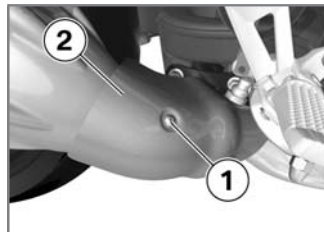

- Install bolt **1** of muffler cover **2**.
- Remove auxiliary stand if mounted.

Front wheel stand

Front wheel stand

A front wheel stand for simple, safe changing of the front wheel is available from BMW Motorrad. The front wheel stand with the BMW special tool number 36 3 971 can be obtained from your authorized BMW Motorrad retailer. You also need the adapters with the BMW special tool number 36 3 973.

 The BMW Motorrad front wheel stand is not designed for holding motorcycles without a center or other auxiliary stands. A motorcycle standing on the front wheel stand and the rear wheel alone can fall over. Place the motorcycle on the center stand or an auxiliary stand before lifting it with the

BMW Motorrad front wheel stand. ◀

Mounting front wheel stand

- Place motorcycle on an auxiliary stand; BMW Motorrad recommends BMW Motorrad rear wheel stand.
- Installing rear-wheel stand (➡ 103) with OA Center stand:
- Make sure ground is level and firm and place motorcycle on its center stand. ◀

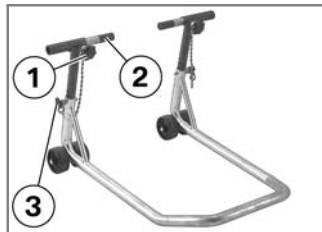

- Loosen adjusting screws **1**.
- Push two mounting pins **2** far enough apart that front suspension fits between them.
- Use locating pins **3** to set front wheel stand to desired height.
- Center the front wheel stand relative to the front wheel and push it against the front axle.



- Push two mounting pins **2** through triangles of brake caliper support toward inside so that front wheel can still be rolled through.

! With BMW Integral ABS the ABS sensor ring can be damaged.

Only push the mounting pin so far inward that it does not touch the sensor ring of the BMW Integral ABS. ◀

- Tighten adjusting screws **1**.



! If the motorcycle is resting on the center stand: The motorcycle is raised too far at the front, the center stand lifts off the ground and the motorcycle can tip over to the side.

When raising the motorcycle, make sure that the center stand remains on the ground. ◀

- Apply uniform pressure to push the front wheel stand down and raise the motorcycle.

Rear-wheel stand

Rear-wheel stand

In order to be able to work safely on motorcycles without center stands, BMW Motorrad offers a rear wheel stand. This rear wheel stand with the BMW special tool number 36 3 980 can be obtained from your authorized BMW Motorrad retailer.

Installing rear-wheel stand

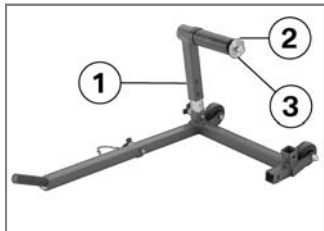

- Set the desired height of the rear wheel stand using the bolts **1**.
- Remove the lock washer **2**; to do so, press the unlock button **3**.

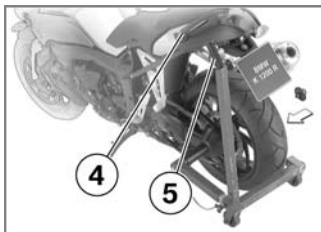

- Push the rear wheel stand from the left into the rear axle.
- Apply the retaining disk from the right; to do so, press the unlock button.
- Place your left hand on the left grab handle of the motorcycle **4** and your right hand on the lever of the rear wheel stand **5**.

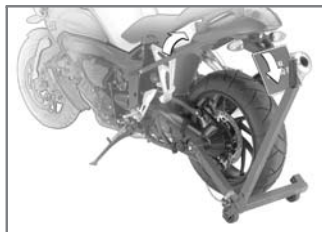

- Raise the motorcycle while simultaneously pressing the lever downward until the motorcycle stands vertically.



- Press the lever onto the ground.

Lights

General instructions

The failure of a bulb is signaled in the display by the lamp defect symbol. If the brake or rear light fails, the general warning light also lights up in yellow. If the rear light fails, the brake light is used as a substitute in that the luminosity of the second glow filament is reduced to rear light level. Failure of the rear light is nevertheless indicated in the display.

! A defective bulb places your safety at risk because it is easier for other users to oversee you and your motorcycle.

Replace defective bulbs as soon as possible; always carry a complete set of spare bulbs if possible. ◀

! The bulb is pressurized and can cause injury if damaged. Wear eye and hand protection when replacing bulbs. ◀

▷ An overview of the bulb types installed in your motorcycle is provided in the chapter "Technical Data". ◀

▷ Do not touch the glass of new bulbs with your fingers. For installation, use a clean, dry cloth. Dirt deposits, in particular oil and grease, interfere with heat radiation from the bulb. Overheating and therefore short service life of the bulbs are the consequence. ◀

Replacing low-beam and high-beam bulb

! If it is not standing firmly, the motorcycle could

tumble in the course of the operations described below. Make sure that the motorcycle is steady on its stand. ◀

▷ To achieve better accessibility, turn the handlebars to the left. ◀

- Make sure ground is level and firm and park the motorcycle.
- Switch off ignition.

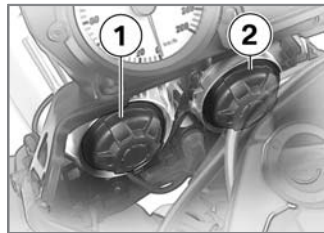

- Remove cover **1** (high-beam headlight) or cover **2** (low-beam headlight) by turning counterclockwise.

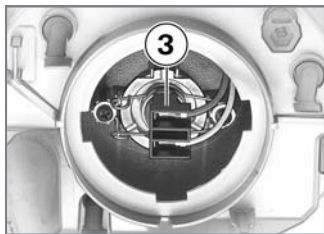

- Disconnect plug **3**.

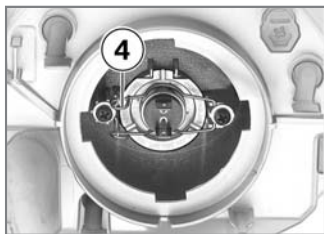

- Remove spring strap **4** from detents and fold up.

▶ The alignment of the spring strap may differ

from the illustration depending on the bulb. ◀

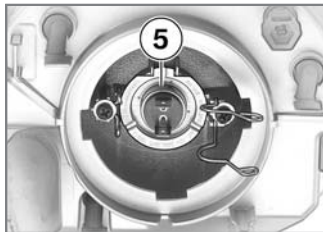

- Remove bulb **5**.
- Replace defective bulb.



High-beam headlight bulb

- H7 / 12 V / 55 W



Low-beam headlight bulb

- H7 / 12 V / 55 W

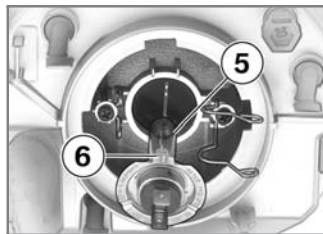

- Install bulb **5**. On assembly, make sure that lug **6** points upwards.

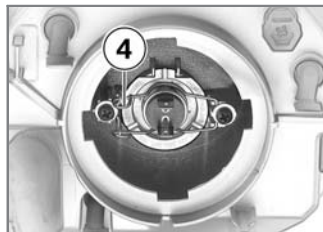

- Install spring straps **4** in locks.

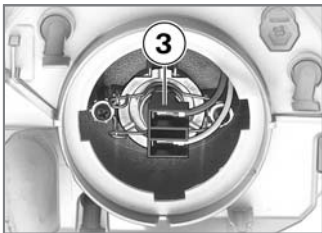

- Close connector **3**.

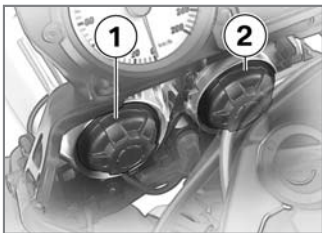

- Install cover **1** (high-beam headlight) or cover **2** (low-beam headlight) by turning clockwise.

Replacing parking light bulb

⚠ If it is not standing firmly, the motorcycle could topple in the course of the operations described below. Make sure that the motorcycle is steady on its stand. ◀

- Make sure ground is level and firm and park the motorcycle.
- Switch off ignition.



- Remove mounting screws **1** on both sides of lamp housing.

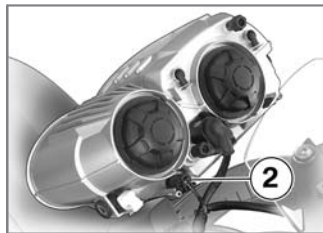

- Pull out lamp housing toward front and fold down slightly.
- Remove bulb holder **2** from headlight housing by turning it counterclockwise.

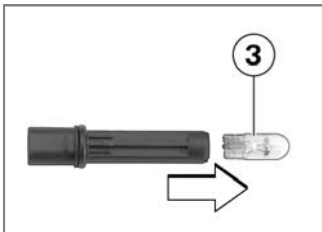

- Remove bulb **3** from bulb holder.
- Replace defective bulb.

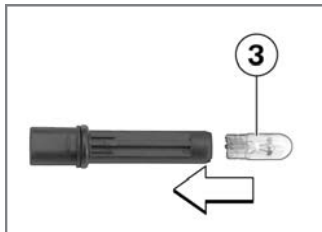

- Insert bulb **3** into bulb socket.
- Install bulb socket in headlight housing by turning clockwise.

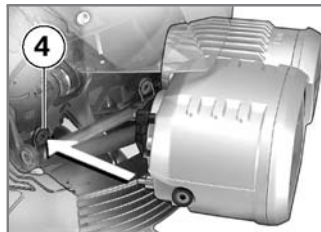
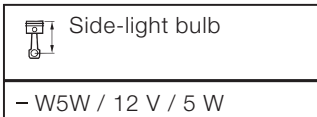

 Incorrectly routed headlight cables can become entangled in the steering. Secure electrical cables with the corresponding retaining clips on the rear wall of the headlight. ◀

- Press lamp housing into mounts **4** on frame.



- Install mounting screws **1** on both sides of lamp housing.

Replacing brake and tail light bulb

⚠ If it is not standing firmly, the motorcycle could topple in the course of the operations described below. Make sure that the motorcycle is steady on its stand. ◀

- Make sure ground is level and firm and park the motorcycle.
- Removing seat (➡ 55)

- Switch off ignition.

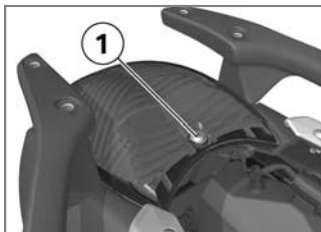

- Remove screw **1**.

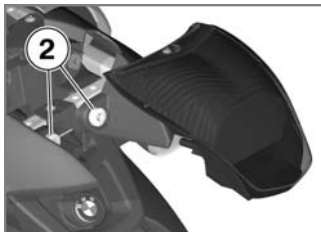

- Pull bulb housing toward rear until it is clear of holders **2**.



- Turn bulb holder **3** counter-clockwise to remove it from bulb housing.

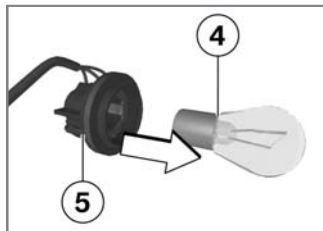

- Press bulb **4** into fitting **5** and remove it by turning it counterclockwise.

- Replace defective bulb.



Bulb of tail/brake light

- P21W / 12 V / 21 W

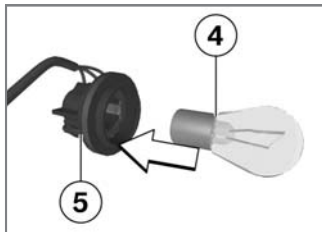

- Press bulb **4** into fitting **5** and install it by turning it clockwise.



- Install bulb socket **3** in lamp housing by turning clockwise.

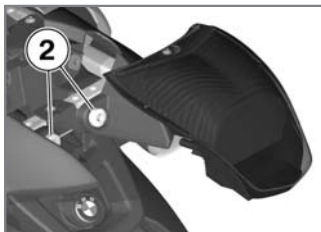

- Insert lamp housing in holders **2**.

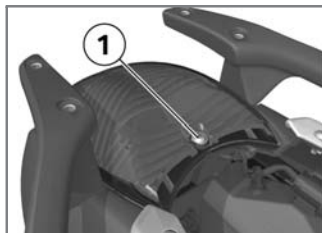

- Install screw **1**.

Replacing front and rear turn indicator bulbs

! If it is not standing firmly, the motorcycle could topple in the course of the operations described below. Make sure that the motorcycle is steady on its stand. ◀

- Make sure ground is level and firm and park the motorcycle.
- Switch off ignition.



- Remove screw **1**.



- Pull lamp housing on screw connection side out of turn indicator housing.

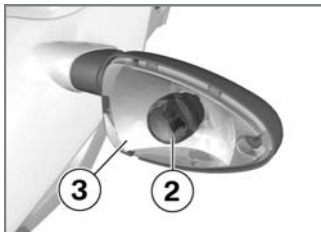

- Press bulb **2** into fitting **3** and remove it by turning it counterclockwise.
- Replace defective bulb.

 Bulb of front turn indicators
- R10W / 12 V / 10 W with OE White turn indicators:
- RY10W / 12 V / 10 W<

 Bulb of rear turn indicators
- R10W / 12 V / 10 W with OE White turn indicators:
- RY10W / 12 V / 10 W<

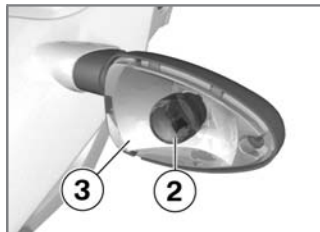

- Install bulb **2** by turning clockwise in bulb socket **3**.

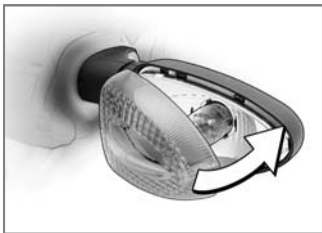

- Place lamp housing on turn indicator housing.



- Install screw **1**.

Jump-starting

⚠ The wires leading to the onboard socket do not have a load-capacity rating adequate for jump-starting the engine. Excessively high current can lead to a cable fire or damage to the motorcycle electronics.

Do not use the onboard socket to jump-start the motorcycle. ◀

⚠ Touching live parts of the ignition system with the engine running can cause electric shock.

Do not touch parts of the ignition system when the engine is running. ◀

⚠ A short-circuit can result if the crocodile clips of the jump leads are accidentally brought into contact with the motorcycle.

Use only jump leads fitted

with fully insulated crocodile clips at both ends. ◀

⚠ Jump-starting with a donor-battery voltage higher than 12 V can damage the motorcycle electronics. The battery of the donor vehicle must have a voltage of 12 V. ◀

⚠ If it is not standing firmly, the motorcycle could topple in the course of the operations described below. Make sure that the motorcycle is steady on its stand. ◀

- When jump-starting the engine, do not disconnect the battery from the onboard electrical system.
- Removing battery compartment cover (➔ 114)
- Run engine of donor vehicle during jump-starting.
- Begin by connecting one end of red jump lead

to positive terminal of discharged battery and other end to positive terminal of donor battery.

- Then connect one end of black jumper lead to negative terminal of donor battery, and other end to negative terminal of discharged battery.
- Start engine of motorcycle with discharged battery in usual way; if engine refuses to start, wait a few minutes before repeating attempt to protect starter and supporting battery.
- Allow both engines to idle for a few minutes before disconnecting the jump leads.
- Disconnect the jump lead from the negative terminals first, then disconnect the second lead from the positive terminals.

- Installing battery compartment cover (➔ 114)

Battery

Maintenance instructions

Correct upkeep, recharging and storage will prolong the life of the battery and are essential if warranty claims are to be considered.

Compliance with the points below is important in order to maximize battery life:

- Keep the surface of the battery clean and dry
- Do not open the battery
- Do not top up with water
- Be sure to read and comply with the instructions for charging the battery on the following pages
- Do not turn the battery upside down



If the battery is not disconnected, the onboard electronics (clock etc.) will drain the battery. This can cause the battery to run flat. If this happens, warranty claims will not be accepted.

During periods when the motorcycle is not being used, of more than four weeks, disconnect the battery from the motorcycle or connect a trickle charger to the battery. ◀



BMW Motorrad has developed a trickle-charger specially designed for compatibility with the electronics of your motorcycle. Using this charger, you can keep the battery charged during long periods when the motorcycle is not being used without having to disconnect the battery from the motorcycle's onboard systems. Additional

information is available at your authorized BMW Motorrad retailer. ◀

Charging connected battery

 Charging the connected battery directly at the battery terminals can damage the motorcycle electronics. To charge the battery via the battery terminals, disconnect the battery first. ◀

 Charging the battery via the onboard socket is only possible with suitable chargers. Unsuitable chargers can result in damage to the motorcycle electronics. Use BMW chargers with the part numbers 71 60 7 688 864 (220 V) or 71 60 7 688 865 (110 V). If in doubt, charge the

disconnected battery directly at the terminals. ◀

 If you switch on the ignition and the multifunction display and indicator lights fail to light up, the battery is completely flat. Attempting to charge a completely flat battery via the onboard socket can cause damage to the motorcycle's electronics.

Always charge a completely drained battery directly at the terminals of the disconnected battery. ◀

- Charge disconnected battery via onboard socket.

 The motorcycle's onboard electronics know when the battery is fully charged. The onboard socket is switched off when this happens. ◀

- Comply with operating instructions of the charger.

 If you are unable to charge the battery via the onboard socket, you may be using a charger that is not compatible with your motorcycle's electronics. In this case, please charge the battery directly at the terminals of the disconnected battery. ◀

Charging disconnected battery

- Charge battery using a suitable charger.
- Comply with operating instructions of the charger.
- Once battery is fully charged, disconnect charger terminal clips from battery terminals.

▷ In the case of longer periods when the motorcycle is not being used, the battery must be recharged regularly. See the instructions for caring for your battery. Always fully recharge the battery before returning it to use.◀

Removing battery compartment cover

⚠ If it is not standing firmly, the motorcycle could topple in the course of the operations described below. Make sure that the motorcycle is steady on its stand.◀

- Make sure ground is level and firm and park the motorcycle.
- Removing seat (⇒ 55)

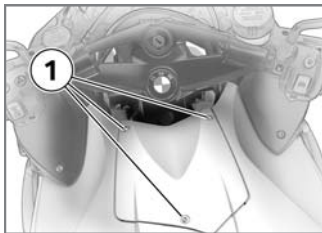

- Remove screws **1**.

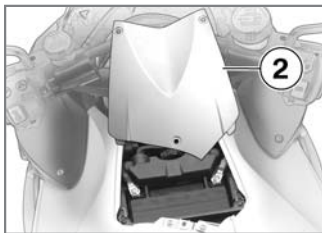

- Remove battery compartment cover **2** forward and upward.

Installing battery compartment cover

⚠ If it is not standing firmly, the motorcycle could topple in the course of the operations described below. Make sure that the motorcycle is steady on its stand.◀

- Make sure ground is level and firm and park the motorcycle.

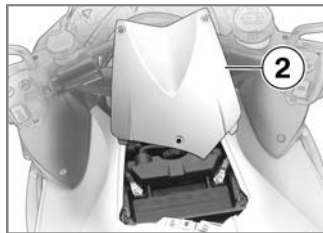

- Install battery compartment cover **2**.

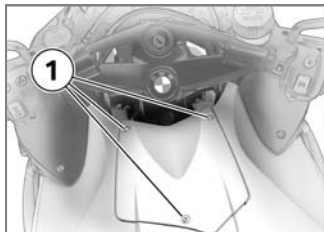

- Install screws **1**.
- Installing seat (➔ 55)

Removing battery

- Removing battery compartment cover (➔ 114)

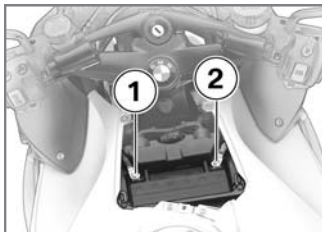

! An incorrect disconnection sequence increase the risk of short-circuiting. Always observe the proper sequence. ◀

- Remove battery ground wire **1** first.
- Then remove positive battery cable **2**.



- Unscrew screws **3** and pull retaining bracket toward rear.
- Lift battery upwards; if it is difficult to move, moving it back and forth will help.

Installing battery

- Switch off ignition.
- Place the battery in the battery compartment, positive terminal on the right in the direction of travel.



- Push retaining strap over battery and install screws **3**.

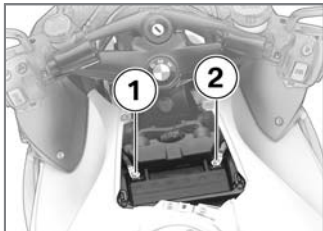

-  An incorrect installation sequence increases the risk of short-circuiting.

Always observe the proper sequence. ◀

- First install positive battery cable **2**.
- Then install negative battery cable **1**.
- Installing battery compartment cover (➡ 114)
- Switch on ignition.
- Fully open the throttle once or twice.
 - » The engine management system records the throttle-valve position.
- Setting clock (➡ 45)

Care

Care products	118
Washing your motorcycle	118
Cleaning sensitive motorcycle parts	119
Paint care	120
Protective wax coating	120
Storing motorcycle	120
Returning motorcycle to use	120

Care products

We recommend that you use cleaning and care products available at your authorized BMW Motorrad retailer. BMW Care Products have been materials tested, laboratory tested, and field tested and provide optimum care and protection for the materials used in your motorcycle.

 The use of unsuitable cleaning and care products can damage motorcycle components.

For cleaning, do not use any solvents such as nitro-thinners, cold cleaning agents, fuel or similar, and do not use cleaning agents that contain alcohol. ◀

Washing your motorcycle

We recommend that you use BMW insect remover to soften and wash off insects and resilient dirt on painted parts prior to washing the motorcycle.

To prevent stains, do not wash the motorcycle immediately after it has been exposed to strong sunlight and do not wash it in the sun. Make sure that the motorcycle is washed frequently, especially during the winter months.

To remove road salt, clean the motorcycle with cold water immediately after every trip.

 After the motorcycle has been washed, ridden through water or ridden in the rain, the brake disks and pads

might be wet and the brakes might not take effect immediately.

Brake early until the brakes are dry or braked until dry. ◀

 Warm water intensifies the effect of salt.

Only use cold water to remove road salt. ◀

 The high pressure of steam cleaners can damage seals, the hydraulic brake system, the electrical system and the seat.

Do not use a steam jet or high-pressure cleaning equipment. ◀

Cleaning sensitive motorcycle parts

Plastics

Clean plastic parts with water and BMW plastic care emulsion. This includes in particular:

- Windshields
- Headlight lens made of plastic
- Covering glass of the instrument cluster
- Black, unpainted parts

 If plastic parts are cleaned using unsuitable cleaning agents, the surfaces can be damaged.

Do not use cleaning agents that contain alcohol, solvents or abrasives to clean plastic parts.

'Fly sponges' or sponges with hard surfaces can also lead to scratches. ◀

 Soften stubborn dirt and dead insects by covering the affected areas with a wet cloth. ◀

Windshield

Clean off dirt and insects with a soft sponge and plenty of water.

 Fuel and chemical solvents attack the windshield material; the windshield becomes cloudy or dull.

Do not use cleaning agents. ◀

Chrome

Especially in the case of road salt, carefully clean chrome parts with plenty of water and BMW auto shampoo. Use chrome polish for additional treatment.

Radiator

Clean the radiator regularly to prevent overheating of the engine due to inadequate cooling.

For example, use a garden hose with low water pressure.

 Cooling fins can be bent easily.

When cleaning the radiator, ensure that the fins are not bent. ◀

Rubber

Treat rubber components with water or BMW rubber protection coating agent.

 Using silicone sprays for the care of rubber seals can cause damage.

Do not use silicon sprays or other care products that contain silicon. ◀

Paint care

Washing the motorcycle regularly will help counteract the long-term effects of substances that damage the paint, especially if your motorcycle is ridden in areas with high air pollution or natural sources of dirt, e.g. tree resin or pollen.

However, remove particularly aggressive materials immediately; otherwise changes in the paint or discoloration can occur. These include spilled fuel, oil, grease, brake fluid as well as bird droppings. BMW Car Polish or BMW Paint Cleaner are recommended for this.

Contamination of the paint finish is particularly easy to see after the motorcycle has been washed. Remove this type of soiling with cleaning naphtha or spirit on a clean cloth

or cotton ball. We recommend removing tar spots with BMW tar remover. Then add a protective wax coating to the paint at these locations.

Protective wax coating

For the protective wax coating of paint, we recommend using only BMW auto wax or agents that contain carnauba or synthetic waxes.

The best way to see whether the paint has to be protected is that water no longer forms pearls.

Storing motorcycle

- Clean motorcycle.
- Remove battery.
- Spray brake and clutch lever, and main and side stand pivots with a suitable lubricant.

- Coat bare metal and chrome-plated parts with an acid-free grease (e.g. Vaseline).
- Park motorcycle in a dry room so that both wheels are unloaded.

 Before storing the vehicle, have the engine oil and the oil filter element changed by a specialized workshop, preferably an authorized BMW Motorrad retailer. Combine work for storing/returning to use with maintenance service or an inspection. ◀

Returning motorcycle to use

- Remove protective wax coating.
- Clean the motorcycle.
- Install a charged battery.

- Before starting: Observe checklist.

Technical data

Troubleshooting chart	124
Threaded fasteners	125
Engine	126
Riding specifications	129
Clutch	129
Transmission	129
Rear-wheel drive	131
Running gear	131
Brakes	132
Wheels and tires	132
Electrical system	133
Frame	135
Dimensions	135
Weights	136

Troubleshooting chart

Engine does not start at all or is very difficult to start

Possible cause	Remedy
Emergency ON/OFF switch activated.	Emergency ON/OFF switch in operating position.
Side stand extended and gear engaged.	Retract side stand (➡ 66).
Gear engaged and clutch not operated	Place transmission in neutral or disengage clutch (➡ 66).
Clutch disengaged with ignition switched off.	Switch on ignition first, then disengage clutch.
No fuel in tank.	Refueling (➡ 71)
Battery not adequately charged.	Charging connected battery (➡ 113)

Threaded fasteners

Front wheel	Value	Valid
Front brake caliper on wheel carrier		
M8 x 32 - 10.9	22 lb/ft (30 Nm)	
Clamping screw on quick-release axle in wheel carrier		
M8 x 30	14 lb/ft (19 Nm)	
Quick-release axle in threaded bush		
M24 x 1.5	37 lb/ft (50 Nm)	
Rear wheel	Value	Valid
Rear wheel on wheel flange		
M10 x 40 x 1.25	Tighten diagonally	
	44 lb/ft (60 Nm)	
Muffler on right passenger footrest		
M8 x 30	12 lb/ft (16 Nm)	

Rear wheel	Value	Valid
Muffler on manifold		
M8 x 60 - 10.9	26 lb/ft (35 Nm)	

Mirrors	Value	Valid
Mirror on clamping piece		
M10	13 lb/ft (18 Nm)	
Clamping piece on clamping block		
	7 lb/ft (10 Nm)	

Engine

Engine design	Transverse-mounted four-cylinder, four-stroke inline engine, angled 55° toward front. With four valves per cylinder, actuated by two overhead camshafts and trailing valve levers; liquid cooled, electronic fuel injection, integrated six-speed cassette transmission, dry-sump lubrication
Effective displacement	1157 cc (1157 cm ³)
Cylinder bore	3.1 in (79 mm)

Piston stroke	2.3 in (59 mm)
Compression ratio	13:1
Rated output	163 hp (120 kW), At: 10250 min ⁻¹
with OE 74 kW power reduction:	101 hp (74 kW), At: 7000 min ⁻¹
with OE 79 kW power reduction:	107 hp (79 kW), At: 8750 min ⁻¹
Maximum torque	94 lb/ft (127 Nm), At: 8250 min ⁻¹
with OE 74 kW power reduction:	81 lb/ft (110 Nm), At: 5250 min ⁻¹
with OE 79 kW power reduction:	76 lb/ft (103 Nm), At: 4500 min ⁻¹
Permissible maximum engine speed	11000 min ⁻¹
Idle speed	1150±50 min ⁻¹
Fuel	
Recommended fuel type	98 ROZ/RON, Super Plus unleaded 95 ROZ/RON, Super unleaded (fuel type can be used with reduced performance and consumption)
Fuel tank capacity	5 gal (19 l), Usable 1.1 gal (4 l), Of that reserve

Engine oil	
Total engine oil capacity	3.7 quarts (3.5 l), With filter change 0.5 quarts (0.5 l), Difference between Min and Max
Lubricant	Castrol GPS 10W-40 (SAE 10W40; API SG; JASO MA)
Oil grades	Mineral engine oils of the API classification SF to SH. BMW Motorrad does not recom- mend using oil additives, as these can wors- en clutch operation. Ask your BMW Motor- rad retailer for engine oils suitable for your motorcycle.
Permissible viscosity classes	
SAE 10 W-40	≥ -4 °F (≥ -20 °C), Operation at low tempera- tures
SAE 15 W-40	≥ 14 °F (≥ -10 °C)

Riding specifications

Top speed	>124 mph (>200 km/h)
-----------	----------------------

Clutch

Clutch design	Multi-disk oil-bath clutch
---------------	----------------------------

Transmission

Transmission design	Claw-shifted 6-speed cassette transmission integrated in engine housing
---------------------	---

Gear ratios

Transmission gear ratios	1.559 (92:59 teeth), Primary gear ratio 2.294 (39:17 teeth), 1st gear 1.789 (34:19 teeth), 2nd gear 1.458 (35:24 teeth), 3rd gear 1.240 (31:25 teeth), 4th gear 1.094 (35:32 teeth), 5th gear 0.971 (33:34 teeth), 6th gear 1.045 (23:22 teeth), Angle drive
--------------------------	---

Rear-wheel drive

Rear-wheel drive design	Shaft drive with bevel gears
Gear ratio of rear-wheel drive	2.91:1

Running gear

Front suspension design	Double leading link
Total spring travel of front suspension	4.5 in (115 mm), Static 4.9 in (125 mm), Dynamic
Rear-wheel suspension design	Lever-system-coupled central spring strut with coil pressure spring and single-tube gas-filled shock absorber. Spring preload with stepless hydraulic adjustment; rebound-stage damping with stepless adjustment
with OE Electronic Suspension Adjustment (ESA):	Lever-system-coupled central spring strut with coil pressure spring and single-tube gas-filled shock absorber. 3x spring base, tensile and compression stage each 3x adjustable
Total suspension travel of rear-wheel suspension	5.3 in (135 mm), On wheel

Brakes

Front brake design	Hydraulic two-disk brake with 4-piston fixed calipers and floating brake disks
Front brake-pad material	Sintered metal
Rear brake design	Hydraulic disk brake with 2-piston floating caliper and fixed brake disk
Rear brake-pad material	Organic

Wheels and tires

Front wheel design	Cast aluminum, MT H2
Front-wheel rim size	3.50" x 17"
Front-wheel tire designation	120/70 ZR17
Rear wheel design	Cast aluminum, MT H2
Rear-wheel rim size	5.50" x 17"
with OE Sports wheel:	6.00" x 17"
Rear-wheel tire designation	180/55 ZR17
with OE Sports wheel:	190/50 ZR17

Tire pressures

Front tire pressure	36.3 psi (2.5 bar), Single rider, with cold tire 36.3 psi (2.5 bar), Driver with passenger and/or load, with cold tire
Rear tire pressure	42.1 psi (2.9 bar), Single rider, with cold tire 42.1 psi (2.9 bar), Driver with passenger and/or load, with cold tire

Electrical system

Rated load of onboard socket	5 A
Fuses	All circuits are electronically protected, so plug-in fuses are no longer necessary. If an electronic fuse trips and de-energizes a circuit, the circuit is active as soon as the ignition is switched on after the fault has been rectified.

Type

Battery design	AGM (Absorptive Glass Matt) battery
----------------	-------------------------------------

Technical data

Battery nominal voltage	12 V
Battery nominal capacity	14 Ah

Technical data	
Spark plug manufacturer and designation	NGK KR9CI
Spark-plug electrode gap	0.03 in (0.8 mm), New
Spark-plug electrode gap (Wear limit)	No wear limit, spark plug is replaced after maintenance interval
Bulbs	
High-beam headlight bulb	H7 / 12 V / 55 W
Low-beam headlight bulb	H7 / 12 V / 55 W
Side-light bulb	W5W / 12 V / 5 W
Bulb of tail/brake light	P21W / 12 V / 21 W
Bulb of front turn indicators	R10W / 12 V / 10 W
with OE White turn indicators:	RY10W / 12 V / 10 W
Bulb of rear turn indicators	R10W / 12 V / 10 W
with OE White turn indicators:	RY10W / 12 V / 10 W
Bulb of license plate light	W5W / 12 V / 5 W

Frame

Frame design	Cast light allow/welded design with screwed-on tubular steel rear frame
Location of type plate	On rear cross frame tube
Location of vehicle identification number	At front right on frame side-section

Dimensions

Motorcycle length	90.1 in (2288 mm)
Motorcycle height	48.4 in (1230 mm), At DIN unladen weight, measured across mirrors
Motorcycle width	33.7 in (856 mm), Across mirrors
Driver's seat height	32.3 in (820 mm), At unladen weight
with OE Low dual seat:	31.1 in (790 mm), At unladen weight

Weights

Unladen weight	522 lbs (237 kg), DIN unladen weight, ready for road, 90 % full tank of gas, without OE
Permissible gross weight	992 lbs (450 kg)
Maximum payload	470 lbs (213 kg)

Service

BMW Motorrad Service	138
BMW Motorrad Service Quality	138
BMW Motorcycle Service Card - breakdown service on the road	139
BMW Motorrad Service Network	139
Maintenance work	139
Maintenance schedules	140
Confirmation of maintenance work	141
Confirmation of service	146

BMW Motorrad Service

Advanced technology requires specially adapted methods of maintenance and repair.

 If this maintenance and repair work is performed inexpertly, there is a danger of damage and associated safety risks.

BMW Motorrad recommends having corresponding work on your motorcycle carried out by a specialized workshop, preferably by an authorized BMW Motorrad retailer. ◀

You can contact your authorized BMW Motorrad retailer for information on the procedures included in BMW service, inspections and the annual inspection.

Have all maintenance and repair work carried out con-

firmed in the "Service" chapter in this manual.

Your authorized BMW Motorrad retailer is supplied with all the latest technical information and therefore possesses the necessary technical know-how. BMW Motorrad recommends that you refer any questions about your motorcycle to your authorized BMW Motorrad retailer.

BMW Motorrad Service Quality

BMW Motorrad means not only quality workmanship and high reliability, but also an outstanding quality of service. To ensure that your BMW is always in optimum condition, we recommend that you adhere to the regular maintenance schedule for your motorcycle, preferably having the work done by your authorized

BMW Motorrad retailer. Proof of regular maintenance is essential for generous treatment of warranty claims.

Certain signs of wear, moreover, may otherwise not be noticed until it is too late to correct them at moderate cost. The workshop personnel at BMW Motorrad retailers have thorough knowledge of your motorcycle and can take action before minor problems can turn into major trouble. By having the necessary repairs done properly and in good time, you save time and money in the long run.

BMW Motorcycle Service Card - breakdown service on the road

With all new BMW motorcycles, the BMW Motorrad Service Card protects you in the event of a breakdown with an extensive range of services such as breakdown assistance, motorcycle transportation etc. (differing regulations are possible in individual countries). In the case of a breakdown, contact the Mobile Service of BMW Motorrad. Here you will find our specialists ready to help with both advice and action. Important country-specific contact addresses and the relevant after-sales service organization phone numbers as well as information on Mobile Service and the retail network

can be found in the "Service Kontakt/Service Contact" brochures.

BMW Motorrad Service Network

With our worldwide service network we support you and your motorcycle in over 100 countries around the globe. In Germany alone, there are approximately 200 authorized BMW Motorrad retailers ready to assist you.

All information on the international retail network is contained in the "Service Contact Europe" brochure and "Service Contact Africa, America, Asia, Australia and Oceania".

Maintenance work Intervals

Some maintenance tasks must be performed after a certain time, others depend on the distance covered by the motorcycle.

BMW Running-In Check

The BMW running-in check must be performed when the motorcycle has covered between 300 miles (500 km) and 750 miles (1,200 km).

BMW Annual Inspection

Some maintenance work must be carried out at least once a year. Other tasks depend on the distance the motorcycle has covered.

BMW Service

After the first 6,000 miles (10,000 km) and every additional 12,000 miles (20,000 km) (18,000 miles, 30,000 miles, 42,000 miles etc. (30 000 km, 50 000 km, 70 000 km etc.)) if this distance is covered within a year.

BMW Inspection

After the first 12,000 mi/20,000 km and every additional 12,000 mi/20,000 km (24,000 mi/40,000 km, 36,000 mi/60,000 km, 48,000 mi/80,000 km, etc.), if this distance is covered within a year.

Maintenance schedules

The maintenance schedule for your motorcycle depends on the equipment installed, and on the motorcycle's age and the distance it has covered. Your authorized BMW Motorrad retailer will be happy to supply a copy of the current maintenance schedule for your motorcycle on request.

Confirmation of maintenance work

BMW Pre-Delivery Check

Carried out properly in accordance with workshop specifications.

Date, stamp, signature

BMW Running-In Check

Carried out properly in accordance with workshop specifications.

Odometer reading_____

Brake fluid changed

Date, stamp, signature

BMW Service

- BMW Annual Inspection
- BMW Service
- BMW Inspection

Carried out properly in accordance with workshop specifications.

Odometer reading _____

- Brake fluid changed

Date, stamp, signature

BMW Service

- BMW Annual Inspection
- BMW Service
- BMW Inspection

Carried out properly in accordance with workshop specifications.

Odometer reading _____

- Brake fluid changed

Date, stamp, signature

BMW Service

- BMW Annual Inspection
- BMW Service
- BMW Inspection

Carried out properly in accordance with workshop specifications.

Odometer reading _____

- Brake fluid changed

Date, stamp, signature

BMW Service

- BMW Annual Inspection
- BMW Service
- BMW Inspection

Carried out properly in accordance with workshop specifications.

Odometer reading _____

- Brake fluid changed

Date, stamp, signature

BMW Service

- BMW Annual Inspection
- BMW Service
- BMW Inspection

Carried out properly in accordance with workshop specifications.

Odometer reading _____

- Brake fluid changed

Date, stamp, signature

BMW Service

- BMW Annual Inspection
- BMW Service
- BMW Inspection

Carried out properly in accordance with workshop specifications.

Odometer reading _____

- Brake fluid changed

Date, stamp, signature

BMW Service

- BMW Annual Inspection
- BMW Service
- BMW Inspection

Carried out properly in accordance with workshop specifications.

Odometer reading _____

- Brake fluid changed

Date, stamp, signature

BMW Service

- BMW Annual Inspection
- BMW Service
- BMW Inspection

Carried out properly in accordance with workshop specifications.

Odometer reading _____

- Brake fluid changed

Date, stamp, signature

BMW Service

- BMW Annual Inspection
- BMW Service
- BMW Inspection

Carried out properly in accordance with workshop specifications.

Odometer reading _____

- Brake fluid changed

Date, stamp, signature

BMW Service

- BMW Annual Inspection
- BMW Service
- BMW Inspection

Carried out properly in accordance with workshop specifications.

Odometer reading _____

- Brake fluid changed

Date, stamp, signature

BMW Service

- BMW Annual Inspection
- BMW Service
- BMW Inspection

Carried out properly in accordance with workshop specifications.

Odometer reading _____

- Brake fluid changed

Date, stamp, signature

BMW Service

- BMW Annual Inspection
- BMW Service
- BMW Inspection

Carried out properly in accordance with workshop specifications.

Odometer reading _____

- Brake fluid changed

Date, stamp, signature

Work carried out	Odometer reading	Date

- A**
 - Abbreviations and symbols, 6
 - Anti-theft alarm, 18
- B**
 - Battery
 - Battery charging-current warning indicator, 28
 - Battery compartment, 13
 - Charging connected battery, 113
 - Charging disconnected battery, 113
 - Installing, 114, 115
 - Removing, 114, 115
 - Technical data, 133
 - Brake fluid
 - Checking front level, 89
 - Checking rear level, 90
 - Brake lever
 - Adjusting handbrake lever, 51
 - Brake pads
 - Checking front, 87
 - Checking rear, 88
- Brakes
 - Fluid reservoir, 13
 - Front fluid tank, 13
 - Rear fluid reservoir, 13
 - Technical data, 132
- C**
 - Case
 - Adapting, 82
 - Adjusting, 80
 - Closing, 80
 - Mounting, 82
 - Opening, 80
 - Removing, 81
 - Checklist, 66
 - Clock, 22
 - Adjusting, 45
 - Clutch
 - Adjusting clutch lever, 51
 - Checking operation, 91
 - Fluid reservoir, 11
 - Technical data, 129
 - Commissioning, 120
 - Confirmation of maintenance work, 141
- D**
 - Dimensions
 - Technical data, 135
- E**
 - Electrical system
 - Technical data, 133
 - Emergency ON/OFF switch, 17, 50
 - Engine
 - Engine-electronics warning indicator, 27
 - Starting, 66
 - Technical data, 126
 - Temperature display, 22, 23
 - Engine oil
 - Checking level, 85
 - Display for engine oil level, 13
 - Draining, 87
 - Engine oil-level warning indicator, 28
 - Engine oil-pressure warning indicator, 27
 - Fill location, 15

Technical data, 128
Topping up, 86

ESA, 60
Adjusting damping, 61
Adjusting spring preload, 61
Calling up settings, 60

EWS
Warning indicator, 26

F

Frame
Technical data, 135

Front wheel stand
Mounting, 101

Fuel
Fill location, 13
Quantity indicator, 22
Refueling, 71
Reserve-quantity warning indicator, 26
Technical data, 127

Fuses, 133

G

Gear indicator, 22

H

Handlebar fittings
General view, left, 16
General view, right, 17

Hazard warning flashers, 16, 17
Switching off, 43
Switching on, 42

Headlight
High-beam headlight, 19
Low-beam headlight, 19
Side lights, 19

Headlight flasher, 16

Heated hand grips, 17, 50

Helmet holder, 15, 56

High-beam headlight, 16

Horn, 16

I

Ignition
Switching off, 40
Switching on, 40

Immobilizer
Warning indicator, 26

Indicator lights, 18

Instrument cluster
Lighting sensor, 18
Overview, 18

J

Jump-starting, 111

L

Lamps
Defective bulb warning indicator, 29
General instructions, 104
Replacing brake light bulb, 108
Replacing front turn indicator bulbs, 109
Replacing high-beam bulb, 104
Replacing low-beam bulb, 104
Replacing parking light bulb, 106
Replacing rear turn indicator bulbs, 109
Replacing tail light bulb, 108
Technical data, 134

Lights

- Switching off parking light, 53
- Switching on high-beam headlight, 52
- Switching on low-beam headlight, 52
- Switching on parking light, 53
- Switching on side lights, 52

M

Maintenance

- General instructions, 84
- Intervals, 139

Mirrors

- Adjusting, 57, 58

Motorcycle

- General view of left side, 11
- General view of right side, 13
- Returning to use, 120
- Storing, 120

Multifunction display, 18, 22

O

- Odometer and tripmeters, 22
 - Button, 16
 - Operation, 43
 - Resetting tripmeter, 44
 - Selecting readings, 43
- Onboard computer
 - Ambient temperature, 47
 - Average consumption, 48
 - Average speed, 47
 - Button, 16
 - Oil level, 49
 - Range, 49
 - Resetting average consumption, 48
 - Resetting average speed, 48
 - Selecting readings, 46
- Onboard socket, 11
- Overview of warning indicators, 24, 32, 36

P

- Pre-ride check, 67

R

- Rear shock absorber system
 - Adjusting, 11, 59
- Rear suspension preload
 - Adjusting, 11, 58
- Rear-wheel drive
 - Technical data, 131
- Rear-wheel stand
 - Mounting, 103
- Refueling, 71
- Reserve
 - Warning indicator, 26
- Residual range, 44
- Running gear
 - Technical data, 131

S

Seat

- Installing, 55
 - Lock, 11
 - Removing, 55
- ### Service, 138
- Service Card, 139
- ### Side stand
- During starting, 66
- ### Spark plugs, 134

Speedometer, 18
Starter, 17
Steering lock, 41
Storing, 120

T

Tachometer, 18
Technical data
 Battery, 133
 Brakes, 132
 Bulbs, 134
 Clutch, 129
 Dimensions, 135
 Electrical system, 133
 Engine, 126
 Engine oil, 128
 Frame, 135
 Fuel, 127
 Rear-wheel drive, 131
 Running gear, 131
 Spark plugs, 134
 Transmission, 129
 Weights, 136
 Wheels and tires, 132

Tire Pressure Control
 Display, 22
 Operation, 46
 Sticker on wheel rim, 93

Tires
 Approved, 93
 Checking air pressure, 61
 Checking tread depth, 92
 Technical data, 132

Toolkit, 15
 Service set, 84
 Standard set, 84

Torques, 125

Transmission
 During starting, 66
 Technical data, 129

Troubleshooting chart, 124

Turn indicators
 Left, 16, 54
 Right, 17, 54
 Switching off, 17, 54

V

Vehicle Identification Number, 13

W

Warning indicators, 22
 Display, 23

Warning lamps, 18

Weights
 Technical data, 136

Wheels
 Installing front wheel, 95
 Installing rear wheel, 99
 Removing front wheel, 93
 Removing rear wheel, 97
 Technical data, 132

Details described or illustrated in this booklet may differ from the motorcycle's actual specification as purchased, the accessories fitted or the national-market specification. No claims will be entertained as a result of such discrepancies.

Dimensions, weights, fuel consumption and performance data are quoted to the customary tolerances. The right to modify designs, equipment and accessories is reserved.

Errors and omissions excepted.

© 2006 BMW Motorrad

Not to be reproduced either wholly or in part without written permission from BMW

Motorrad, After Sales.

Printed in Germany.

The most important data for a filling station stop can be found in the following chart.

Fuel	
Recommended fuel type	98 ROZ/RON, Super Plus unleaded 95 ROZ/RON, Super unleaded (fuel type can be used with reduced performance and consumption)
Fuel tank capacity	5 gal (19 l), Usable 1.1 gal (4 l), Of that reserve
Tire pressures	
Front tire pressure	36.3 psi (2.5 bar), Single rider, with cold tire 36.3 psi (2.5 bar), Driver with passenger and/or load, with cold tire
Rear tire pressure	42.1 psi (2.9 bar), Single rider, with cold tire 42.1 psi (2.9 bar), Driver with passenger and/or load, with cold tire

BMW recommends 

Order No.: 01 47 7 706 137
06.2006, 3rd Edition



Please attach this sticker to the inside back cover page of your Rider's Manual

Reporting Safety Defects

If you believe that your vehicle has a defect which could cause a crash or could cause injury or death, you should immediately inform the National Highway Traffic Safety Administration (NHTSA) in addition to notifying BMW of North America, LLC.

If NHTSA receives similar complaints, it may open an investigation, and if it finds that a safety defect exists in a group of vehicles, it may order a recall and remedy campaign. However, NHTSA cannot become involved in

individual problems between you, your dealer, or BMW of North America, LCC.

To contact NHTSA, you may call the Vehicle Safety Hotline toll-free at 1-888-327-4236

(TTY: 1-800-424-9153); go to <http://www.safercar.gov>, or write to: Administrator, NHTSA, 400 Seventh Street, SW., Washington, DC 20590. You can also obtain other information about motor vehicle safety from <http://www.safercar.gov>.

BMW Motorrad

Order No: 01 47 7 706 697

08.2006