

Rider's Manual (US Model)

K 1200 S



BMW Motorrad



Motorcycle/Retailer Data

Motorcycle data

Model

Vehicle identification number

Color number

First registration

Registration number

Retailer Data

Contact in Service

Ms./Mr.

Phone number

Retailer's address/phone number
(company stamp)

Welcome to BMW

We congratulate you on your choice of a motorcycle from BMW and welcome you to the community of BMW riders.

Familiarize yourself with your new motorcycle so that you can ride it safely and confidently in all traffic situations. Please read this Rider's Manual carefully before starting to use your new BMW motorcycle. It contains important information on how to operate the controls and how to make the best possible use of all your BMW's technical features.

In addition, it contains information on maintenance and care to help you maintain your motorcycle's reliability and safety, as well as its value.

If you have any questions concerning your motorcycle,

your authorized BMW motorcycle retailer will gladly provide advice and assistance.

We wish you many miles of safe and enjoyable riding

BMW Motorrad.

Table of Contents

You can also use the index at the end of this Rider's Manual to find a specific topic.

1 General instructions ... 5

Overview	6
Abbreviations and symbols	6
Equipment	7
Technical data	7
Currency	7

2 Overviews 9

General view, left side ...	11
General view, right side	13
Underneath seat	14
Left handlebar fitting	15
Handlebar fitting, right ...	16
Instrument cluster	17
Headlight	18

3 Status indicators 19

Multifunction display	20
Warning and indicator lights	20
ABS warning light	20
Function indicators	20
General warning indicators	21
ABS warning indicators	28

4 Operation 35

Ignition switch and steering lock	36
Electronic immobilizer....	37
Hazard warning flashers	38
Tripmaster	39
Onboard computer ^{OE}	41
Clock	44
Emergency ON/OFF switch	45
Heated hand grips ^{OE}	45
Clutch	46
Brakes	46
Lights	47

Headlight	48
Turn indicators	49
Seat	50
Helmet holder	52
Luggage loops	53
Mirrors	53
Spring preload	53
Shock absorbers	54
Electronic suspension adjustment ESA ^{OE}	55
Tires	57

5 Riding 59

Safety instructions	60
Checklist	62
Starting	62
Starting off	65
Running in	65
Parking your motorcycle	69
Refueling	76
General brake system ...	77
Brake system with BMW Integral ABS	77

6 Accessories	81	Jump starting	117	Wheels and tires.....	136
General instructions	82	Battery	119	Electrical system	137
Onboard socket	82	8 Care	123	Frame.....	139
Luggage	85	Care products	124	Dimensions	139
Case ^{OA}	86	Washing your		Weights	140
Flat tire kit ^{OA}	89	motorcycle	124	10 Service	141
7 Maintenance	91	Cleaning sensitive		BMW Motorrad	
Maintenance - General		motorcycle parts	125	service	142
Information	92	Paint care	126	BMW Motorrad service	
Toolkit	92	Protective wax		quality	142
Contents of supplemental		coating	126	BMW Motorcycle Service	
set ^{OA}	92	Storing motorcycle	126	Card - breakdown	
Overview of supplemental		Returning motorcycle to		service on the road	143
set.....	92	use	126	BMW Motorrad service	
Engine oil	92	9 Technical data	129	network	143
General brake system.....	94	Troubleshooting		Maintenance work	143
Brake pads.....	95	chart.....	130	Maintenance	
Brake fluid	97	Threaded fasteners	131	schedules	144
Clutch	100	Engine	132	Confirmation of	
Tires	100	Riding specifications	134	maintenance work	145
Rims.....	101	Clutch	134	Confirmation of	
Wheels.....	101	Transmission	134	service	150
Front wheel stand	108	Rear-wheel drive	135		
Rear-wheel stand.....	110	Running gear.....	135		
Lamps	111	Brakes	136		

General instructions

Overview	6
Abbreviations and symbols	6
Equipment	7
Technical data	7
Currency	7

Overview

Chapter 2 of this Rider's Manual will provide you with an initial overview of your motorcycle. All maintenance and repair work carried out on your motorcycle will be documented in Chapter 10. For generous treatment of claims submitted after the warranty period has expired, proof of the maintenance performed is essential.

Should you want to sell your BMW one day, please also remember to turn over the Rider's Manual to the new owner; it is an important part of your motorcycle.

Abbreviations and symbols



Indicates warnings that you must comply with for reasons of your safety and the safety of others, and to protect your motorcycle against damage.



Special information on operating and inspecting your motorcycle as well as maintenance and adjustment procedures.



Indicates the end of an item of information.



Instruction.



Result of an activity.



Reference to a page with more detailed information.

OE	Optional equipment BMW equipment available only as a factory installed option.
OA	Optional accessories BMW optional accessories can be purchased and retrofitted at your authorized BMW motorcycle retailer.
EWS	Electronic immobilizer.
ESA	Electronic Suspension Adjustment Electronic suspension adjustment.
DWA	Anti-theft alarm.
ABS	Anti-Lock Brake System.

Equipment

When you ordered your BMW motorcycle, you chose various items of custom equipment. This Rider's Manual describes optional equipment (OE) offered by BMW and selected optional accessories (OA). This explains why the manual may also contain descriptions of equipment which you have not ordered. Please note, too, that your motorcycle might not be exactly as illustrated in this manual on account of country-specific differences.

If your BMW is equipped with options or accessories not described in this Rider's Manual, then this equipment is described in a separate operating manual.

Technical data

All dimensions, weights and performance specifications in the Rider's Manual refer to the standards of the Deutsche Institut für Normung e.V. (DIN) and comply with its tolerance specifications. Versions for individual countries may differ.

Currency

The high safety and quality standards of BMW motorcycles are maintained by constant development work on designs, equipment and accessories. Because of this, your motorcycle may differ from the information supplied in the Rider's Manual. Nor can errors and omissions be entirely ruled out. We hope you will appreciate that no claims can be entertained on

the basis of the data, illustrations or descriptions in this manual.

Overviews

General view, left side	11
General view, right side	13
Underneath seat	14
Left handlebar fitting	15
Handlebar fitting, right	16
Instrument cluster	17
Headlight	18

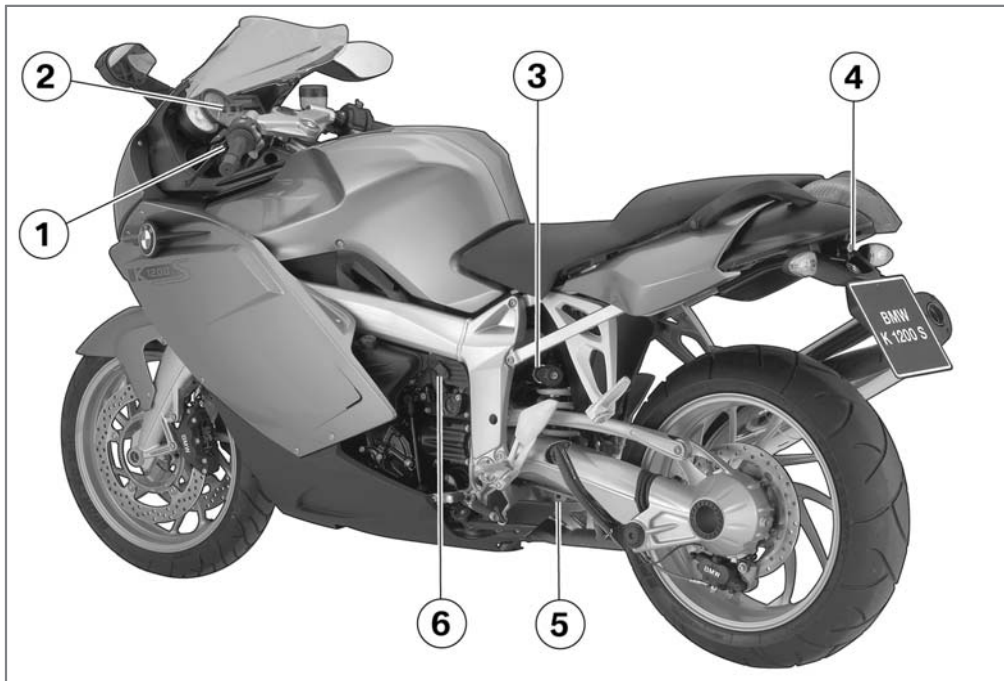

General view, left side

- 1 Adjusting headlight range
(➡ 49)
- 2 Clutch fluid reservoir
(➡ 100)
- 3 Adjuster, spring preload,
rear (➡ 54)
- 4 Seat lock beneath rear
light (➡ 50)
- 5 Rear shock absorber
damping adjustment
(➡ 54)
- 6 Onboard socket (➡ 82)

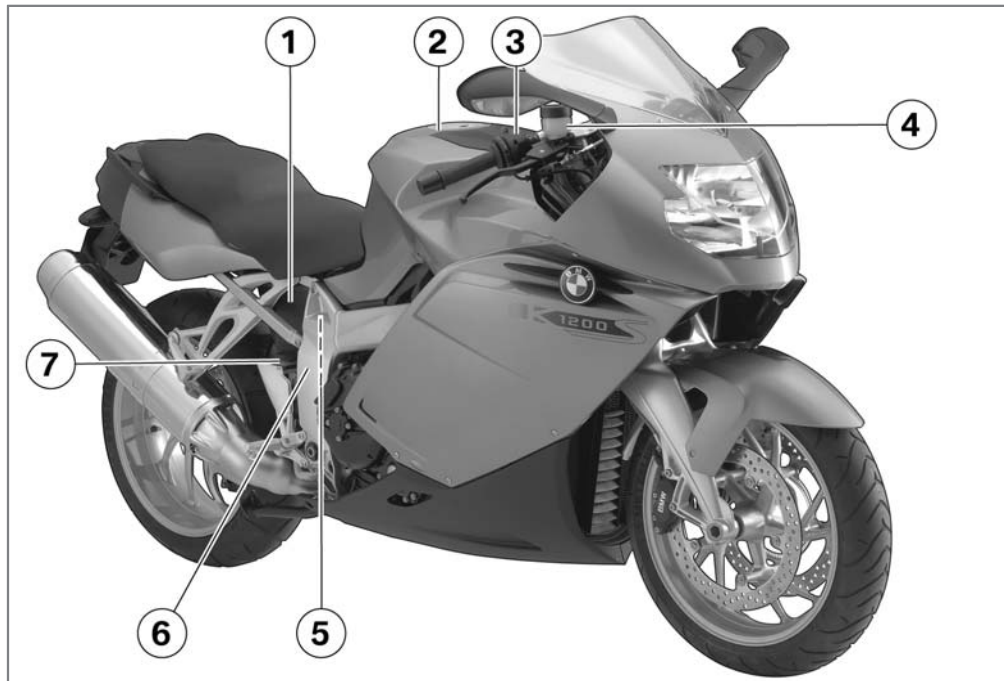

General view, right side

- 1 Display for engine oil level (➡ 92)
- 2 Fill location on fuel tank (➡ 76)
- 3 Battery compartment (➡ 120)
- 4 Brake-fluid reservoir, front (➡ 97)
- 5 Type plate on rear cross tube
- 6 Vehicle identification number (VIN), on front right side panel
- 7 Brake-fluid reservoir, rear (➡ 98)

Underneath seat

- 1 Helmet holder under seat
(➔ 52)
- 2 Toolkit (➔ 92)
- 3 Filler neck, engine oil
(➔ 94)

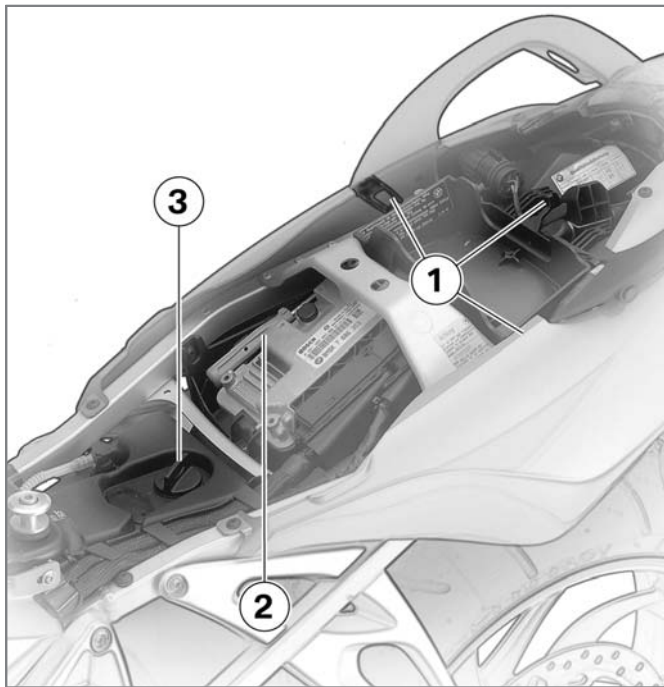

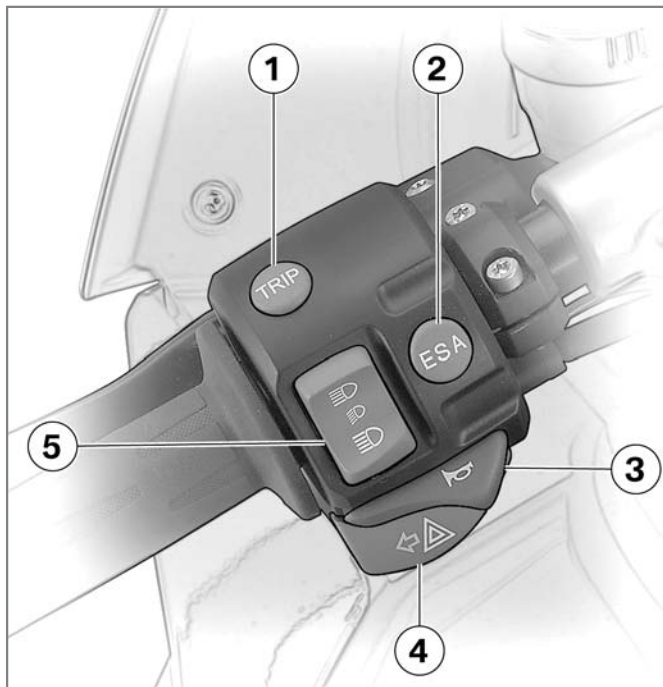

Left handlebar fitting

- 1 Tripmaster/Onboard computer button (OE) (➡ 39) (➡ 41)
- 2 ESA button (➡ 55)
- 3 Pushbutton, horn
- 4 Button for left turn indicator and hazard warning flashers (➡ 49) (➡ 38)
- 5 Switch, high-beam headlight and headlight flasher (➡ 47)

Handlebar fitting, right

- 1 Emergency ON/OFF switch (➡ 45)
- 2 Pushbutton, starter (➡ 62)
- 3 Heated hand grips switch (➡ 45)
- 4 Button for right turn indicator and hazard warning flashers (➡ 49) (➡ 38)
- 5 Off button for turn indicator and hazard warning flashers (➡ 50) (➡ 39)

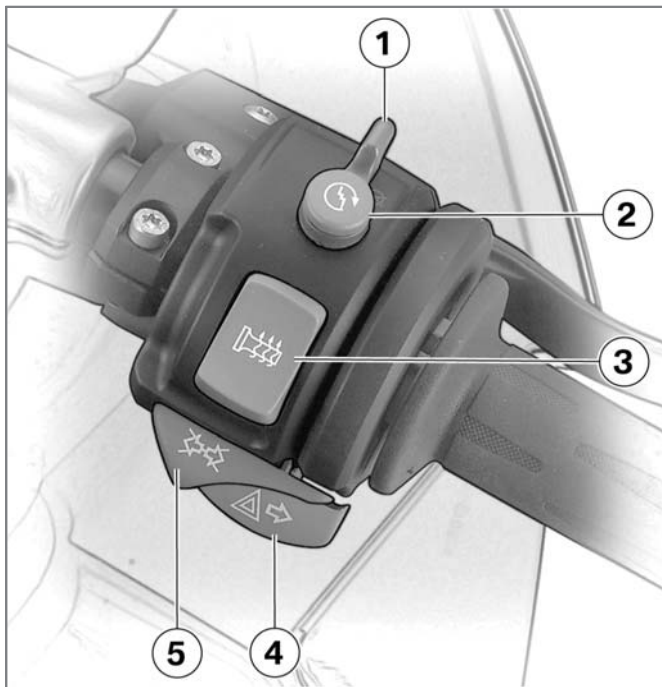

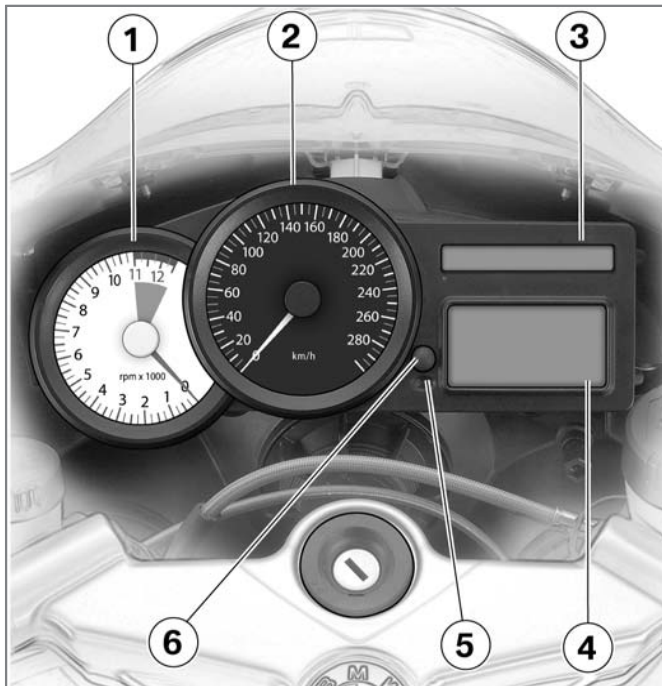

Instrument cluster

- 1 Speedometer
- 2 Tachometer
- 3 Warning and indicator lights (➡ 20)
- 4 Multifunction display (➡ 20)
- 5 Anti-theft alarm indicator light (OE) and sensor for instrument lighting
- 6 Adjustment of clock (➡ 44)

▶ The instrument-cluster lighting has automatic day and night switchover. ◀

Headlight

- 1 High-beam headlights
- 2 Low-beam headlight
- 3 Side light

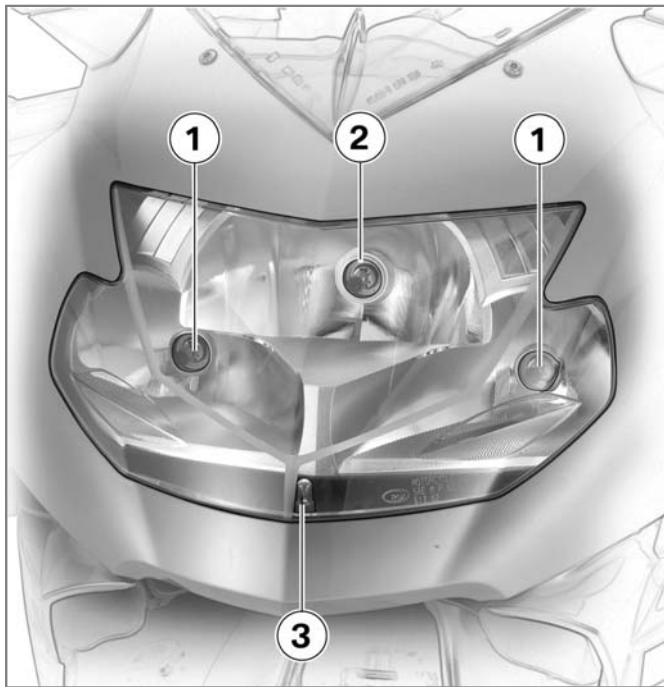

Status indicators

Multifunction display	20
Warning and indicator lights....	20
ABS warning light	20
Function indicators	20
General warning indicators.....	21
ABS warning indicators	28

Multifunction display

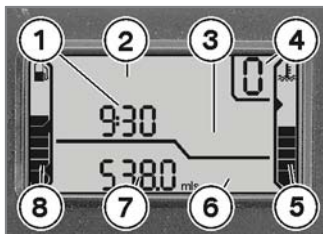

- 1 Clock
- 2 Area for warning symbols (⇒ 21)
- 3 Area for onboard computer displays
- 4 Gear indicator (⇒ 20)
- 5 Engine temperature indicator (⇒ 21)
- 6 Area for ESA displays (⇒ 56)
- 7 Display, Tripmaster (⇒ 39)
- 8 Fuel gauge (⇒ 20)

Warning and indicator lights

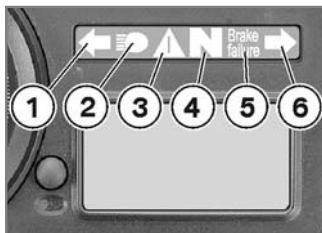

- 1 Indicator light, left turn indicator
- 2 Indicator light, high-beam headlight
- 3 Warning light, general
- 4 Indicator light, neutral
- 5 ABS warning light
- 6 Indicator light, right turn indicator

ABS warning light

In some countries a different display of the ABS warning light is possible.



Alternative display of ABS warning light.

Function indicators

Fuel capacity



The horizontal bars under the gas pump symbol indicated the remaining fuel quantity.

Gear



Engaged gear is indicated.

If no gear is engaged, the gear indicator displays 0; the 'neutral' indicator light also lights up.

Coolant temperature



The lateral bars under the temperature symbol show the coolant temperature level.

General warning indicators











Display

General warnings are displayed by means of texts and symbols in the multifunction display. In some cases, an additional general warning light lights up red or yellow. A number of warnings may be issued simultaneously.

Overview of warning indicators

Display

Meaning

	Lights up yellow		The warning EWS! is indicated	Electronic immobilizer is active (➡ 24)
	Lights up yellow		The warning FUEL! is indicated	Fuel down to reserve (➡ 24)
	Lights up red			Coolant temperature too high (➡ 24)
	Lights up yellow		Is indicated	Engine electronics (➡ 25)
	Lights up red		Is indicated	Engine oil pressure insufficient (➡ 25)
	Lights up red		Is indicated	Battery charge current insufficient (➡ 26)
	Lights up yellow		The warning LAMPR! is indicated	Rear bulb defective (➡ 26)
	The warning LAMPF! is indicated			Front bulb defective (➡ 26)



Display

Meaning

	Lights up yellow	The warning LAMPS! is indicated	Bulbs defective (➡ 27)
--	------------------	---------------------------------	------------------------

	Is indicated		Ice warning (➡ 27)
--	--------------	--	--------------------

	Is displayed with note DWA		Anti-theft alarm battery weak (➡ 27)
--	----------------------------	--	--------------------------------------

	Lights up yellow		Is displayed with note DWA	Anti-theft alarm battery drained (➡ 27)
--	------------------	---	----------------------------	---

Electronic immobilizer is active



General warning light lights up yellow.

The warning EWS ! is indicated.

The key being used is not authorized for starting, or communication between the key and engine electronics is disrupted.

- Remove other ignition keys located on the ignition key.
- Use the reserve key.
- Have the defective key replaced, preferably by an authorized BMW motorcycle retailer.

Fuel down to reserve



General warning light lights up yellow.

The warning FUEL ! is indicated.



A fuel shortage can lead to misfiring and to the engine dying unexpectedly. Misfiring can damage the catalytic converter, and the engine dying unexpected can lead to accidents.

Do not drive until the fuel tank is completely empty. ◀



The Tripmaster indicates the probable residual operating range. ◀

At the most, the fuel tank still contains the reserve fuel quantity.

- Reserve fuel quantity
1.1 gal
- Refueling (➡ 76)

Coolant temperature too high



General warning light lights up red.



The coolant temperature indicator flashes 10 times.



Continued driving with an overheated engine can result in engine damage. Always observe the measures listed below. ◀

The coolant temperature is too high.

- Continued driving is possible; ride in the part-load range to cool down the engine.
- In traffic jams, switch off the engine, but keep the ignition on so that the radiator fan continues to operate.
- Should the coolant temperature frequently be too high, have the fault rectified as quickly as possible by a specialized workshop, preferably an authorized BMW motorcycle retailer.

Engine electronics



General warning light lights up yellow.



Engine electronics symbol is displayed.



The engine is running in emergency operating mode. Engine power may be reduced, and this can cause hazardous situations, particularly if you attempt to overtake other road users.

Adapt your style of riding to the reduced level of engine power. ◀

The engine-electronics control unit has diagnosed a fault. In exceptional cases, the engine stops and can no longer be started. Otherwise, the engine runs in emergency operating mode.

- Continued driving is possible, however the accus-

tomed engine performance may not be available.

- Have the fault rectified as soon as possible by a specialized workshop, preferably an authorized BMW motorcycle retailer.

Engine oil pressure insufficient



General warning light lights up red.



Engine oil pressure symbol is displayed.

The oil pressure in the lubricating oil circuit is too low.

The warning on insufficient engine oil pressure is no substitute for the function of an oil-level indicator. The correct engine oil level can only be checked at the oil sight glass. ◀

The cause of the warning on insufficient engine oil pressure can be an insufficient engine oil level.

- Checking engine oil level (➡ 92)
- Topping up engine oil (➡ 94)

If the warning on insufficient engine oil pressure appears despite a correct engine oil level:



In addition to an insufficient engine oil level, other problems in the engine can lead to the warning on insufficient engine oil pressure. Continuing to ride in these cases can cause engine damage.

If this warning appears, do not continue to ride even though the engine oil level might be correct. ◀

- Do not continue driving.
- Have the fault rectified as soon as possible by a specialized workshop, preferably an authorized BMW motorcycle retailer.

Battery charge current insufficient



General warning light lights up red.



Battery charge current symbol is displayed.



A discharged battery can result in the engine cutting out unexpectedly, causing a hazardous situation. Have faults eliminated as soon as possible. ◀



If the battery is no longer charged, continued driving can lead to deep discharging, and therefore to the destruction of the battery.

If possible, do not continue driving. ◀

The battery is not being charged.

- Continued driving is possible until the battery is discharged. However, the engine can die suddenly and the battery can be exhaustively discharged and therefore destroyed.
- Have the fault rectified as soon as possible by a specialized workshop, preferably an authorized BMW motorcycle retailer.

Rear bulb defective



General warning light lights up yellow.

The warning LAMP R ! is indicated.



A defective bulb places your safety at risk because it is easier for other

users to oversee you and your motorcycle.

Replace defective bulbs as soon as possible; always carry a complete set of spare bulbs if possible. ◀

Rear light or brake light bulb defective.

- Replacing brake light and rear light bulbs (➔ 115)

Front bulb defective

The warning LAMP F ! is indicated.



A defective bulb places your safety at risk because it is easier for other users to oversee you and your motorcycle.

Replace defective bulbs as soon as possible; always carry a complete set of spare bulbs if possible. ◀

Low-beam headlight, high-beam headlight, side-light or turn indicator bulb defective.

- Replacing low-beam bulb (⇒ 112)
- Replacing high-beam bulb (⇒ 113)
- Replacing side-light bulb (⇒ 114)
- Replacing front turn indicator bulb (⇒ 116)
- Replacing rear turn indicator bulb (⇒ 116)

Bulbs defective

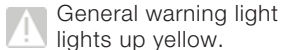

General warning light lights up yellow.

The warning LAMPS! is indicated.



A defective bulb places your safety at risk because it is easier for other users to oversee you and your motorcycle.

Replace defective bulbs as

soon as possible; always carry a complete set of spare bulbs if possible.◀

A combination of several bulb defects is present.

- See the fault descriptions above.

Ice warning



Ice warning symbol is displayed.

The air temperature measured at the motorcycle is lower than 37 °F (3 °C).



The ice warning does not mean that there is no risk of black ice forming at measured temperatures above 37 °F (3 °C).

Always think well ahead when temperatures are low, especially on bridges and where the road is in the shade.◀

- Think well ahead when driving.

Anti-theft alarm battery weak



Battery symbol with note DWA is displayed.

The anti-theft alarm battery no longer has its full capacity. The operation of the anti-theft alarm is only ensured for a limited time with the motorcycle battery disconnected.

- Contact a specialized workshop, preferably an authorized BMW motorcycle retailer.

Anti-theft alarm battery drained



General warning light lights up yellow.



Battery symbol with note DWA is displayed.

The anti-theft alarm battery has no capacity. The operation of the anti-theft alarm is no longer ensured with the

motorcycle battery disconnected.

- Contact a specialized workshop, preferably an authorized BMW motorcycle retailer.

ABS warning indicators

Display

ABS warnings are indicated by a combination of the general warning light and the ABS warning light. Both warning lights can light up continuously or flash at a rate of one or four flashes per second.

The ABS warning light is shown in two versions depending on country:



Country version 1.















Country version 2.

The warning indicators in this chapter are described using country version 1.

Overview of warning indicators

Display

Meaning

	Lights up red		Brake switch defective (➡ 30)
	Flashes 1x per second		Pull-away test not completed (➡ 30)
	Flashes 4x per second		Self-diagnosis not completed (➡ 30)
	Lights up red		Lights up ABS warning lights defective (➡ 31)
	Lights up red		Flashes 1x per second ABS function not available (➡ 31)
	Lights up red		Flashes 4x per second Residual braking function active (➡ 31)
	Flashes red 1x per second		Flashes 1x per second Brake fluid level in wheel brake circuit too low (➡ 32)
	Flashes red 4x per second		Flashes 4x per second ABS error (➡ 33)

Brake switch defective



General warning light lights up red.



There is a defect in the brake system which can lead to delayed braking action, and therefore to accidents.

Brake early, as delayed braking action must be expected. ◀

The brake switch is defective or incorrectly adjusted. The BMW Integral ABS detects the driver's request for braking by the pressure buildup from the brake levers. There may be an unusual response from the brakes.

- Continue driving is possible. However, the brakes may behave in an unaccustomed manner.
- Have the fault rectified as soon as possible by a spe-

cialized workshop, preferably an authorized BMW motorcycle retailer.

Pull-away test not completed



ABS warning light flashes once per second.



Without the ABS function, the wheels may lock up during very hard braking, resulting in accidents. Avoid hard braking whenever possible. ◀

The ABS function is not available, as the pull-away test has not yet been completed.

- Continue driving is possible. However, the ABS function is not available up to the end of the pull-away test.
- Do not use emergency braking if possible until the pull-away test has been completed.

Self-diagnosis not completed



ABS warning light flashes four times per second.



Without the ABS function, the wheels could lock during very hard braking. Without servo-assisted brakes, considerably greater force is required to brake. The altered braking behavior can lead to accidents. Avoid hard braking whenever possible. Brake early, as increased braking force is required. ◀

Only the residual braking function is available in both brake circuits, because self-diagnosis has not been completed.

- Continue driving is possible. The ABS function and the servo assistance are not

available until the end of the self-diagnosis.

- As soon as possible, do not operate the brake lever so that the self-diagnosis can be completed.

ABS warning lights defective



General warning light lights up red.



ABS warning light ON.

 ABS warnings not available. The failure of functions of the BMW Integral ABS cannot be displayed. Unexpected braking behavior, and therefore accidents may result.

Brake early and avoid hard braking whenever possible, as functions of the BMW Integral ABS may have failed. ◀

The controller of the ABS warnings is defective. ABS faults cannot be displayed.

- Continue driving is possible. However, any ABS faults which occur cannot be displayed.
- Have the fault rectified as soon as possible by a specialized workshop, preferably an authorized BMW motorcycle retailer.

ABS function not available



General warning light lights up red.



ABS warning light flashes once per second.



Without the ABS function, the wheels may lock up during very hard braking, resulting in accidents. Avoid hard braking whenever possible. ◀

The ABS function is unavailable in at least one brake circuit.

- Continue driving is possible. However, the ABS function is not available.
- Have the fault rectified as soon as possible by a specialized workshop, preferably an authorized BMW motorcycle retailer.

Residual braking function active



General warning light lights up red.



ABS warning light flashes four times per second.



Without the ABS function, the wheels could lock during very hard braking. Without servo-assisted brakes, considerably greater force is required to brake.

The altered braking behavior can lead to accidents.

Avoid hard braking whenever possible. Brake early, as increased braking force is required. ◀

Only the residual braking function is available in at least one brake circuit.

- Continue driving is possible. The ABS function and the servo assistance are not available.
- Have the fault rectified as soon as possible by a specialized workshop, preferably an authorized BMW motorcycle retailer.

Brake fluid level in wheel brake circuit too low



General warning light flashes red once per second.



ABS warning light flashes once per second.



The ABS wheel brake circuit is a closed system; you cannot check the fluid level in this circuit at the brake-fluid reservoirs. ◀

Triggers for the warning "Brake fluid level too low" can be extremely worn brake pads etc.

- Checking front brake pad thickness (⇒ 95)
- Checking brake pad thickness at rear (⇒ 96)



Worn brake pads can considerably increase the braking distance, and therefore lead to accidents. Brake early. ◀



Worn brake pads can damage the brake disks. Think well ahead and brake

carefully; avoid severe braking. ◀

- Have worn brake pads replaced as soon as possible by a specialized workshop, preferably an authorized BMW motorcycle retailer.

If the brake pad thickness is sufficient, the brake system must be checked for proper operation and leaks.

- Switch off Ignition, then operate handbrake lever and footbrake lever consecutively.
- » The following functions must be available:
 - Brake pressure present at both brake levers.
 - Brakes acting on both wheels.
 - No escaping brake fluid is visible.

 There is a defect in the brake system that can lead to reduced braking action.

Brake early. ◀

- If the functions are active, further driving is possible. However, bear in mind that a loss of brake fluid that cannot be detected might be the cause of the warning.
- Have the fault rectified as soon as possible by a specialized workshop, preferably an authorized BMW motorcycle retailer.

If a fault has been determined during the operating and leak test:

 There is a defect in the brake system that can lead to accidents.

Do not continue driving. ◀

- Do not continue driving.
- Inform a specialized workshop, preferably an authorized BMW motorcycle retailer.

ABS error

 General warning light flashes red four times per second.

 ABS warning light flashes four times per second.

At least two faults have occurred in the brake system. In at least one brake circuit only the residual braking function is available and the fluid level in the brake system is too low.

- Please see the fault descriptions above.

Operation

Ignition switch and steering lock.....	36
Electronic immobilizer	37
Hazard warning flashers	38
Tripmaster	39
Onboard computer ^{OE}	41
Clock	44
Emergency ON/OFF switch	45
Heated hand grips ^{OE}	45
Clutch	46
Brakes	46
Lights	47
Headlight	48
Turn indicators	49
Seat	50

Helmet holder	52
Luggage loops	53
Mirrors	53
Spring preload	53
Shock absorbers	54
Electronic suspension adjustment ESA ^{OE}	55
Tires	57

Ignition switch and steering lock

Keys

You receive one master key and one spare key. If a key is lost, please note the information on the electronic immobilizer (EWS) (➔ 37).

▶ Ignition key and steering lock, tank filler cap lock and seat lock are all operated with the same key. Cases with locks for the same key as the cases available as optional accessories can be ordered on request. ◀

Switching on ignition

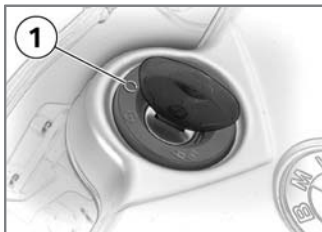

- Turn key to position **1**.
 - » Side lights and all function circuits switched on.
 - » Engine can be started.
 - » Pre-ride check is performed. (➔ 63)
 - » ABS self-diagnosis is performed. (➔ 64)

Switching off ignition

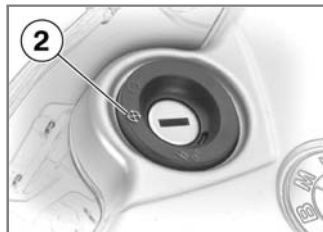

- ⚠ Brake servo assistance is not available when the ignition is off. Do not switch off the ignition while the motorcycle is being ridden. ◀
- Turn key to position **2**.
 - » Light switched off.
 - » Handlebars not locked.
 - » Key can be removed.
 - » Electrically powered accessories remain operational for a limited period of time.
 - » Battery can be recharged via onboard socket.

Locking handlebars

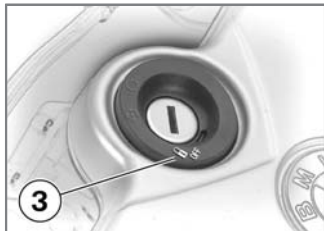

- Turn handlebars to full left or right lock position.
- Turn key to position **3** while moving handlebars slightly.
 - » Ignition, lights and all function circuits switched off.
 - » Handlebars locked.
 - » Key can be removed.

Electronic immobilizer

Theft protection

The electronic immobilizer helps protect your BMW motorcycle from theft, and this enhanced security is at your disposal without any need for you to set parameters or activate additional systems. The engine of a motorcycle equipped with this electronic immobilizer can be started only with the keys that belong to the motorcycle. You can also have your authorized BMW motorcycle retailer bar individual keys, for example

if a particular key is lost. The engine cannot be started with a key that has been barred.

Electronics in key

An electronic component is integrated into each of your keys. The motorcycle's electronics exchange certain continuously changing signals with the electronics in the key; these signals are specific to your motorcycle and they are transmitted via the ring antenna in the ignition lock. The ignition is not enabled for starting until the key has been recognized as "authorized" for your motorcycle.

▶ A spare key attached to the same ring as the ignition key used to start the engine could "irritate" the electronics, in which case the enabling signal for starting is not issued. The warning EWS



When you prop the motorcycle on the side stand, the surface of the ground will determine whether it is better to turn the handlebars to the left or right. However, the motorcycle is more stable on a level surface with the handlebars turned to the left than with the handlebars turned to the right.

On level ground, always turn the handlebars to the left to set the steering lock.◀

is shown in the multifunction display.

Always store the spare key separately from the ignition key. ◀

Replacement and extra keys

You can obtain replacement keys only through an authorized BMW motorcycle retailer. The keys are part of an integrated security system, so the retailer is under an obligation to check the legitimacy of all applications for replacement/extra keys. If you want to have a lost key barred, you must bring along all other keys that belong to the motorcycle. A key that has been barred can subsequently be cleared and reactivated for use.

Hazard warning flashers

Switching on hazard warning flashers

- Switch on ignition.

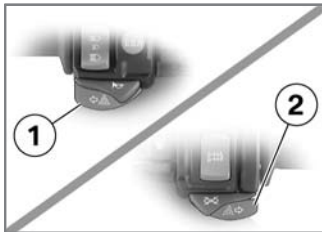

- Press button for left turn indicator **1** and right turn indicator **2** simultaneously.

▶ The hazard warning flashers place a strain on the battery. Do not use the hazard warning flashers for longer than absolutely necessary. ◀

▶ If a turn indicator button is pressed with the ignition switched on, the flashing function replaces the emergency flashing function as long as the button is pressed. If the turn indicator button is released, the emergency flasher function becomes active again. ◀

- » Hazard warning flashers in operation.
- » Left/right turn indicator lights flash.
- Switch off ignition.
- » Hazard warning flashers continue to operate.
- » Left/right turn indicator lights off.

Switching off hazard warning flashers

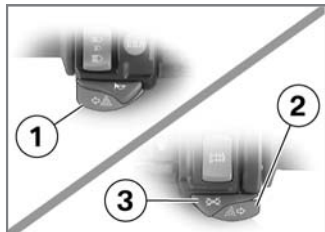

- Press turn-indicator cancel button **3**.
 - » Hazard warning flashers are switched off.
- Alternative: Press button for left turn indicator **1** and right turn indicator **2** simultaneously.
 - » Hazard warning flashers are switched off.

Tripmaster

Tripmaster operation

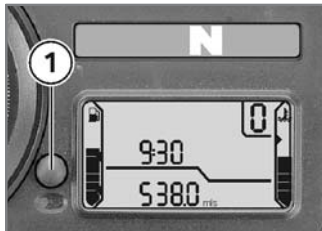

The operation of the Tripmaster described in the following can also be carried out with the button **1** in the instrument cluster as an alternative.

Selecting readings

- Switch on ignition.

▶ When you switch on the ignition, the information shown by the Tripmaster when the ignition was switched off always reappears on the multifunction display. ◀

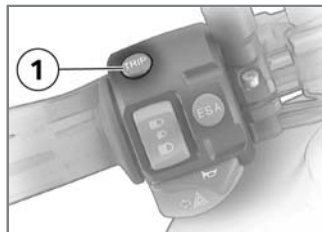

- Press Tripmaster button **1** once briefly.



The following sequence is shown in the display field of the Tripmaster:

- Total distance covered
- Tripmeter 1 (Trip I)

- Tripmeter 2 (Trip II)
- Residual range

Resetting tripmeter

- Switch on ignition.
- Select desired tripmeter.

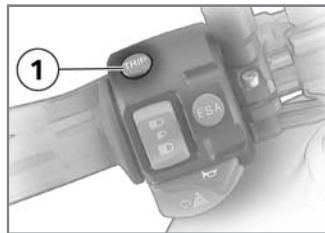

- Press and hold Tripmaster button **1** until display changes.
- » Tripmeter is reset to zero.

Residual range

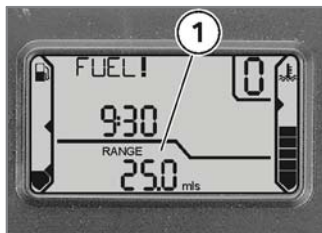

The residual operating range **1** is displayed together with the lettering RANGE only after the reserve fuel level is reached. It is calculated on the basis of your style of riding and the amount of fuel in the tank; the reading indicates the estimated distance you can travel before the fuel supply runs out. If the motorcycle is resting on its side stand, the level in the tank cannot be measured correctly, so this estimate of

residual operating range will be inaccurate.

When refueling, fuel is not registered by the Tripmaster until the quantity added is more approx. a gallon (several liters).

▶ The determined residual range is an approximate reading. BMW Motorrad therefore recommends that you do not try to use the full residual range before refueling. ◀

Onboard computer^{OE} Onboard computer button

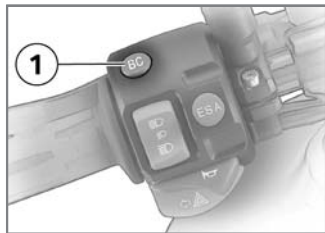

On motorcycles with an onboard computer, the onboard computer (BC) button **1** replaces the Tripmaster button on the handlebar fitting.



In this case the Tripmaster can only be operated with the button **1** in the instrument cluster. The display of the operating range is assumed by the onboard computer.

Selecting readings

- Switch on ignition.



- Press BC button **1** once in each case.



The following sequence is shown in the display field of the onboard computer:

- Clock
- Residual range

- Average speed
- Average consumption
- Oil level
- Ambient temperature

Residual range

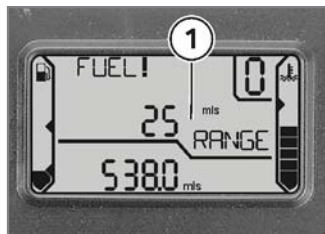

The operating range **1** can also be displayed before the reserve level is reached. The operating description of the operating range in the Trip-master chapter (➔ 40) also applies to the onboard computer.

Calculation of average speed



The average speed **1** is calculated based on the elapsed time since the last "RESET". Times during which the engine was stopped are excluded from the calculation.

Resetting average speed



- Repeatedly press BC button **1** until average speed appears in display.
- Hold down BC button for at least 2 sec. ("RESET").
- Display shows "---.-- km"

Calculation of average consumption

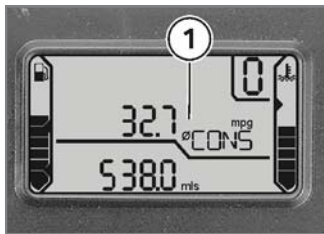

The average consumption **1** is calculated by dividing the distance covered since the last "RESET" by the corresponding amount of fuel used.

Resetting average consumption

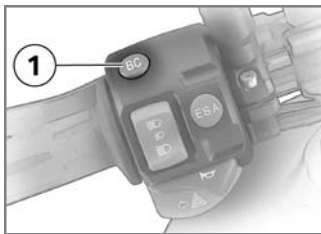

- Repeatedly press BC button **1** until average consumption appears in display.
- Hold down BC button for at least 2 seconds ("RESET").
 - » Display shows "--.- mpg".

Ambient temperature

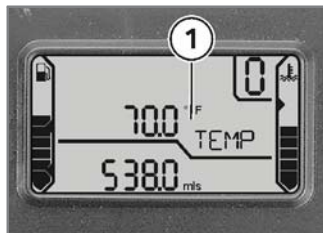

The current ambient temperature **1** is displayed.

 An ice warning appears if the ambient-temperature reading drops below 37 °F (3 °C). The display automatically switches from any other mode to the temperature reading when the temperature drops below this threshold for the first time. The reading flashes until you select some other display mode.

Clock

Setting clock

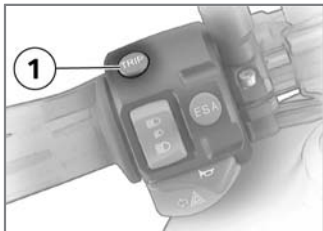

The setting of the clock described in the following can also be carried out with the Tripmaster button **1** as an alternative.

Setting clock

- Switch on ignition.

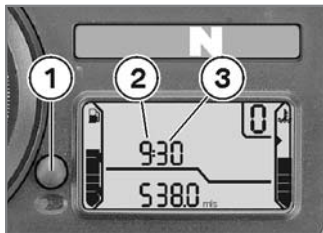

! Attempting to set the clock while riding the motorcycle can lead to accidents.

Adjust the clock only when the motorcycle is stationary. ◀

- Press and hold button **1** until display changes.
 - » Hours reading **2** starts to flash.
- Press button **1**.
 - » The hour increments by one each time you press the button.
- Press and hold button **1** until display changes.

» Minutes reading **3** starts to flash.

- Press button **1**.
 - » The minute increments by one each time you press the button.
- Press and hold button **1** until display changes.
 - » The display stops flashing.
 - » Clock setting ended.

Emergency ON/OFF switch

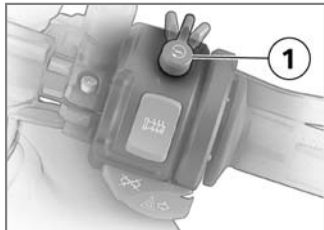



1 Emergency ON/OFF switch.

 Actuating the emergency ON/OFF switch while driving can cause the rear wheel to lock up, resulting in a fall.

Do not operate the emergency ON/OFF switch while riding. ◀

The engine can be easily and quickly switched off using the emergency ON/OFF switch.

 The engine can only be started in the operating position. ◀

 If the emergency ON/OFF switch is operated with the ignition switched on, the BMW Integral ABS continues to function. ◀

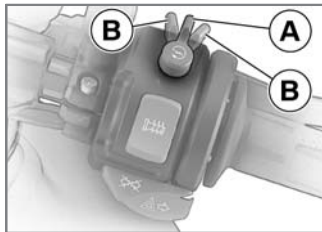

A Operating position
B Engine switched off.

Heated hand grips^{OE}

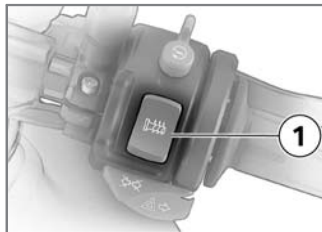

1 Heated hand grips switch

The handlebar grips can be heated at two different levels. The heated hand grips option can only be activated when the engine is running.

 The increase in power consumption caused by the heated hand grips can drain the battery if you are riding at low engine speeds. If the battery is inadequately charged, the heated hand

grips are switched off to ensure starting capability. ◀

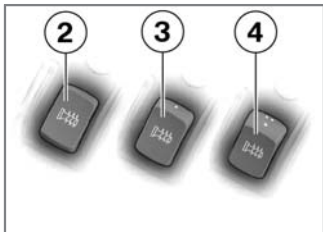

- 2 Heating function off.
- 3 50 % heat output (one dot visible).
- 4 100 % heat output (three dots visible).

Clutch

Adjusting clutch lever

 If the position of the clutch fluid reservoir is changed, air can enter the clutch system.

Do not reposition the handle-

bar controls on the handlebars or the handlebars in their mounts. ◀

 Attempting to adjust the clutch lever while riding the motorcycle can lead to accidents.

Adjust the clutch lever only when the motorcycle is stationary. ◀



- Turn adjusting screw **1** clockwise.

 The adjusting screw has a limit position and can be turned more easily when

you press the clutch lever forward. ◀

» Distance between handlebar grip and clutch lever increases.

- Turn adjusting screw **1** counterclockwise.

» Distance between handlebar grip and clutch lever decreases.

Brakes

Adjusting handbrake lever

 Changing the position of the brake-fluid reservoir can allow air to penetrate the brake system.

Do not reposition the handlebar controls on the handlebars or the handlebars in their mounts. ◀

 Attempting to adjust the brake lever while riding the motorcycle can lead to accidents.

Adjust the brake lever only when the motorcycle is stationary. ◀

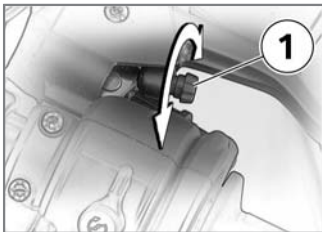

- Turn adjusting screw **1** clockwise.

 The adjusting screw has a limit position and can be turned more easily when you press the handbrake lever forward. ◀

- » Distance between handlebar grip and handbrake lever increases.
- Turn adjusting screw **1** counterclockwise.
- » Distance between handlebar grip and handbrake lever decreases.

Lights

Switching on side lights

The side lights switch on automatically when the ignition is switched on.

 The side lights are a strain on the battery. Do not leave the ignition switched on longer than absolutely necessary. ◀

Switching on low-beam headlight

The low-beam headlight switches on automatically when you start the engine.

 With the engine switched off, you can switch on the lights by switching on the high-beam headlight with the ignition switched on or by operating the headlight flasher. ◀

Switching on high-beam headlight

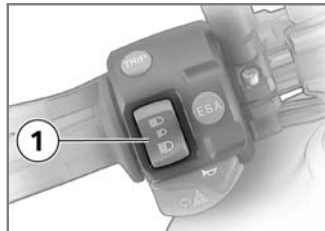

- Press top part of switch **1** for high-beam headlight.

- » High-beam headlight switched on.
- Move switch **1** for high-beam headlight to center position.
- » High-beam headlight switched off.
- Press bottom part of switch **1** for high-beam headlight.
- » High-beam headlight is switched on as long as switch is pressed (headlight flasher).

Switching on side lights

- Switch off ignition.

 You can switch on the parking lights only immediately after switching off the ignition. ◀

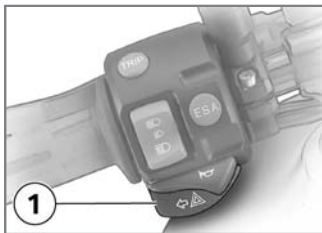

- Press and hold left turn indicator switch **1** until side light is switched on.

Switching off side lights

- Switch on ignition.
- » Side lights switched off.

Headlight

Adjusting headlight for RHD/LHD traffic

When riding in countries where traffic drives on the opposite side of the road to that in which the motorcycle was registered, the asymmetrical

low headlight beam will dazzle oncoming traffic. Have the headlight adjusted to the relevant conditions by a specialized workshop, preferably an authorized BMW motorcycle retailer.



Ordinary adhesive tape damages the plastic lens.

Only use special plastic adhesive film for body applications from specialized retailers. ◀

Headlight range and spring preload

The headlight range generally remains constant due to the adjustment of the spring preload to the loading state. Spring preload adjustment may only be insufficient when the motorcycle is very heavily loaded. In this case, the

headlight range must be adjusted to the weight.

▶ Consult a specialized workshop, preferably an authorized BMW motorcycle retailer, if you are unsure whether the headlight basic setting is correct. ◀

Headlight range adjustment

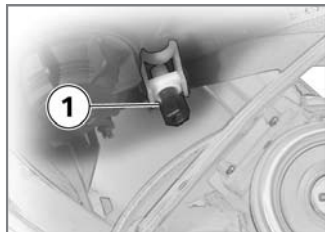

1 Headlight range adjustment

In the case of very high payloads, the available spring

preload adjustment might not be adequate. To avoid dazzling oncoming traffic, the headlight adjustment can be corrected by adjusting the swivel lever.

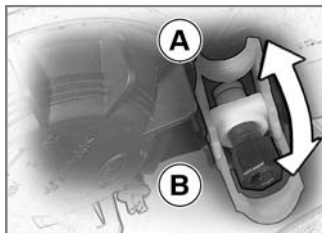

- A** Neutral position
- B** Position with heavy payload

Turn indicators

Switching on left-hand turn indicator

- Switch on ignition.

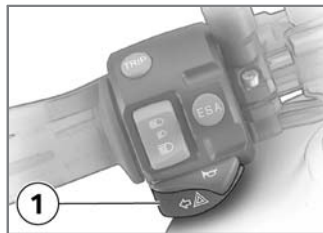

- Press left-hand turn indicator button **1**.

▶ After driving for approx. ten seconds or after covering a distance of approx. 650 ft (200 m), the turn indicators are automatically switched off. ◀

- » Left-hand turn indicator switched on.
- » Indicator light for left-hand turn indicator flashes.

Switching on right-hand turn indicator

- Switch on ignition.

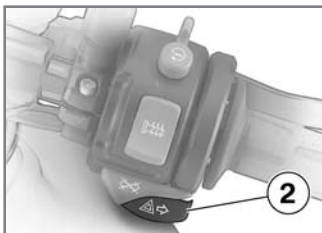

- Press right-hand turn indicator button **2**.

▶ After driving for approx. ten seconds or after covering a distance of approx. 650 ft (200 m), the turn indicators are automatically switched off. ◀

- » Right-hand turn indicator switched on.
- » Indicator light for right-hand turn indicator flashes.

Switching off turn indicators

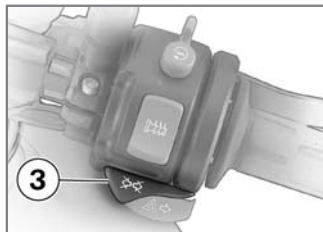

- Press turn-indicator cancel button **3**.
- » Turn indicator switched off.
- » Turn indicator lights in indicator light panel are off.

Seat

Removing seat

- Make sure the ground is level and firm and park the motorcycle.



- Turn the key counterclockwise in the seat lock.

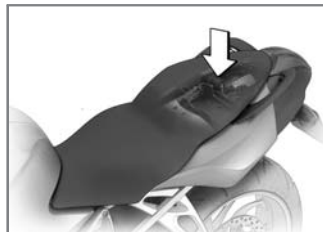

- When doing so, press the seat downwards for support.

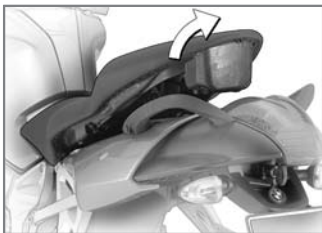

- Raise the seat at the rear.

! If the seat is laid on a rough surface, the seat edges may be damaged. Lay the seat on the reference side on a smooth, clean surface, e.g. on the tank. ◀

- Let go of the key and pull the seat from the retaining bracket towards the rear.

Installing seat

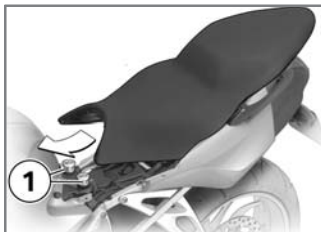

! If too much pressure is applied in the forward direction, there is a danger that the motorcycle will be pushed off its stand. Make sure that the motorcycle is steady on its stand. ◀

- Push seat forward into retaining brackets **1**.

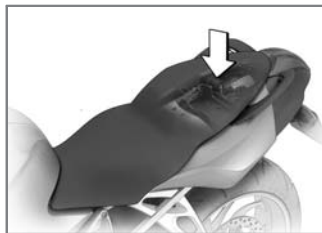

- Press the seat firmly downwards beyond the detent.
» The seat can be heard to lock into place.

Helmet holder

Helmet holder under seat

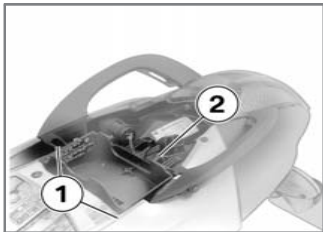

The helmet holders **1** and **2** are located under the seat. A motorcycle helmet with chin strap can be attached to the helmet holders **1**. If cases are fitted or if the chin strap is too short, a steel cable can be used to secure the motorcycle helmet to the helmet holder **2**.

Using helmet holder

- Make sure the ground is level and firm and park the motorcycle.
- Removing seat (→ 50)

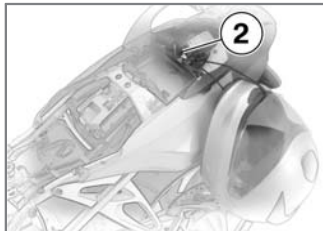

! The helmet catch can scratch the paneling. When hooking on the helmet, watch the position of the helmet lock.◀

- Hook helmet into helmet holder **2** using steel cable available as an optional accessory.

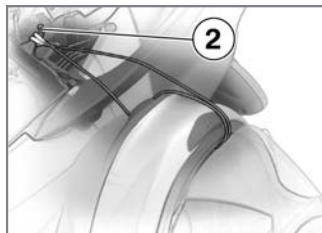

! On the right-hand side of the motorcycle, the helmet could be damaged by heat from the end muffler. Only attach the helmet to the left-hand side of the motorcycle.◀

- Pull steel cable through helmet and hook it into holder **2**.

▷ You can obtain a suitable steel cable from your authorized BMW motorcycle retailer.◀

Luggage loops

Luggage loops under seat

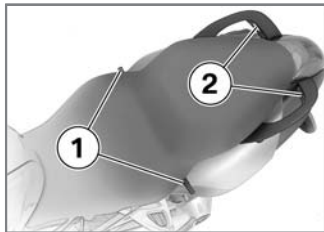

The loops **1** for attaching luggage straps are located on the underside of the seat. In conjunction with the eyelets **2** on the grab handles, luggage can be strapped onto the rear seat.

Use luggage straps

- Make sure the ground is level and firm and park the motorcycle.
- Removing seat (➔ 50)

- Turn over seat.

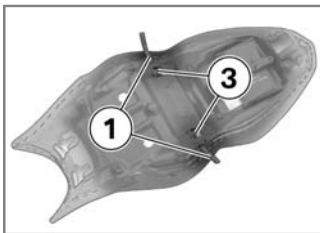

- Pull loops **1** out of retaining bracket **3**.
- » Luggage straps can be hooked into loops.

Mirrors

Adjusting mirrors

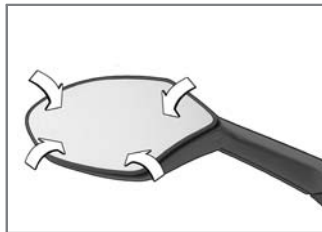

- Move the mirrors into the desired position by pressing lightly on one of the corners.

Spring preload

Adjusting spring preload

The spring preload must be adapted to the load of the motorcycle. Increase spring preload when the motorcycle is heavily loaded and reduce spring preload accordingly.

when the motorcycle is lightly loaded.

Adjusting spring preload for rear wheel

! Your motorcycle's handling will suffer if you do not match the spring-preload and damping-characteristic settings.

Adjust the damping characteristic to suit the spring preload. ◀

! Adjusting the spring preload while the motorcycle is being ridden can lead to accidents. Adjust the spring preload only when the motorcycle is stationary. ◀

- Make sure the ground is level and firm and park the motorcycle.

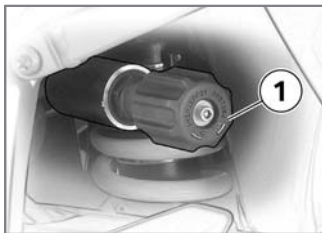

- To increase spring preload, turn handwheel **1** in direction of arrow HIGH.
- To decrease spring preload, turn handwheel **1** in direction of arrow LOW.

▷ One click corresponds to a half turn of the handwheel. The range of adjustment comprises 15 turns. ◀

– Rear wheel spring preload - basic position
Single rider with one person weighing approx. 185 lbs (85 kg)

Turn handwheel as far as possible in direction of arrow LOW, then turn 15 clicks in direction of arrow HIGH

Shock absorbers

Adjusting damping

The damping must be adapted to the spring preload. An increase in spring preload requires firmer damping, a reduction in spring preload requires softer damping.

Adjusting rear shock absorber

! Your motorcycle's handling will suffer if you do not match the spring-preload and damping-characteristic settings.

Adjust the damping characteristic to suit the spring preload. ◀

- Make sure the ground is level and firm and park the motorcycle.

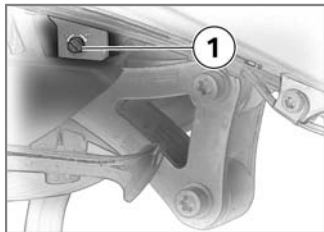

- Adjust rear shock absorber, using a screwdriver to turn adjusting screw **1**.

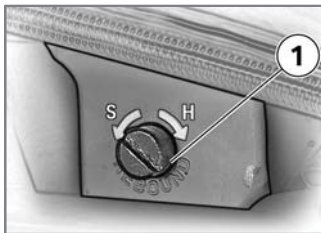

- To increase damping, turn adjusting screw **1** in direction of arrow H.
- To decrease damping, turn adjusting screw **1** in direction of arrow S.

▶ The range of adjustment comprises three and a half turns of the adjusting screw. ◀

- Basic setting for rear-wheel damping
Single rider with one person weighing approx. 185 lbs (85 kg)

Turn adjusting screw as far as possible in direction of arrow H, then turn one and one-half turn in direction of arrow S

Electronic suspension adjustment ESA^{OE}

Settings

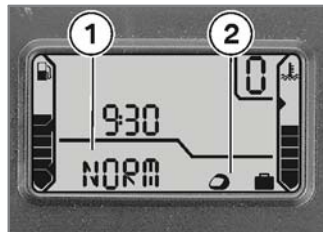

Using the electronic suspension adjustment ESA you can conveniently adjust your motorcycle to various driving conditions. Three spring preloads can be combined with three damping

settings to optimally adapt the motorcycle to the load and the road surface. The damping setting is displayed in the multifunction display in the area **1**, and the spring preload in the area **2**.

The display of the tripmaster is hidden for the duration of the ESA display.

Calling up settings

- Switch on ignition.



- Press button **1**.
- » Current setting is displayed.

» Display goes out automatically after a few seconds.

Adjusting damping

- Switch on ignition.



- Press button **1**.
- » Current setting is displayed.
- Press button **1** once briefly. Starting from the current state, the display is in the following order:
 - COMF comfortable damping
 - NORM normal damping
 - SPORT sporty damping

» If button **1** is not pressed for a longer time, damping is set as indicated. During setting procedure, display flashes.

Adjusting spring preload

- Start engine.



- Press button **1**.
- » Current setting is displayed.
- Press and hold button **1** once.

▶ The spring preload cannot be adjusted while the motorcycle is being ridden. ◀

Starting from the current state, the display is in the following order:



One-up



One-up with luggage



Two-up (with luggage)

» If button **1** is not pressed for a longer time, spring preload is set as indicated. During setting procedure, display flashes.

Tires

Checking tire pressures



Incorrect tire pressure worsens handling of the motorcycle and can lead to accidents.

Ensure proper tire pressure. ◀



At high road speeds, tire valves have a tendency to open as a result of centrifugal force.

To avoid a sudden loss of tire pressure, use a metal valve cap with rubber sealing ring on the rear wheel and tighten it securely. ◀



Incorrect tire pressure reduces the life of the tires.

Ensure proper tire pressure. ◀

- Check correct tire pressure using following data.
 - Front-wheel tire pressure 36.3 psi (In cold state)
 - Rear-wheel tire pressure 42.1 psi (In cold state)

In case of insufficient tire pressure:

- Correct air pressure.

Riding

Safety instructions	60
Checklist	62
Starting	62
Starting off	65
Running in	65
Parking your motorcycle	69
Refueling	76
General brake system	77
Brake system with BMW Integral ABS	77

Safety instructions

Rider's equipment

Do not ride without the correct clothing. Always wear:

- Helmet
- Rider's suit
- Gloves
- Boots

This applies even to short journeys, and to every season of the year. Your authorized BMW motorcycle retailer will be glad to advise you on the correct clothing for every purpose.

Speed

If you ride at high speed, always bear in mind that various boundary conditions can adversely affect the handling of your motorcycle:

- Settings of the spring-strut and shock absorber system
- Imbalanced load
- Loose clothing
- Insufficient tire pressure
- Poor tire tread
- Etc.

Correct loading



Overloading and uneven loading can diminish the riding stability of the motorcycle.

Do not exceed the gross weight limit and observe the loading information.◀

Alcohol and drugs



Even small amounts of alcohol or drugs will adversely affect your perception and your ability to assess situations and make decisions, and slow down your reflexes. Medication can exacerbate these effects.

Do not ride your motorcycle after consuming alcohol, drugs and/or medication.◀

Risk of poisoning

Exhaust fumes contain carbon monoxide, which is colorless and odorless but highly toxic.



Inhaling exhaust fumes therefore represents a health hazard and can even cause loss of consciousness with fatal consequences. Do not inhale exhaust fumes. Do not run the engine in closed rooms.◀

High voltage



Touching live parts of the ignition system with the engine running can cause electric shock. Do not touch parts of the igni-

tion system when the engine is running. ◀

Catalytic converter

If misfiring causes unburned fuel to enter the catalytic converter, there is a danger of overheating and damage.

For this reason, observe the following points:

- Do not run the fuel tank dry
- Do not run the engine with the spark-plug cap removed
- Stop the engine immediately if it misfires
- Use unleaded fuel only
- Comply with all specified maintenance intervals.

 Unburned fuel will destroy the catalytic converter.

Note the points listed for protection of the catalytic converter. ◀

Risk of fire

Temperatures at the exhaust are high.

 Flammable materials (e.g. hay, leaves, grass, clothing and luggage, etc.) could ignite if allowed to come into contact with the hot exhaust pipe.

Make sure that no highly flammable materials can come in contact with the hot exhaust system. ◀

 Cooling would be inadequate if the engine were allowed to idle for a lengthy period with the motorcycle at a standstill: overheating would result. In extreme cases, the motorcycle could catch fire.

Do not run the engine for unnecessary periods when the motorcycle is stationary. After starting, ride off immediately. ◀

Tampering with the control unit of the electronic engine-management system

 Tampering with control unit of electronic engine-management system can damage the motorcycle and cause accidents. Do not tamper with the control unit of the electronic engine-management system. ◀

 Tampering with control unit of electronic engine-management system can result in mechanical loads that the motorcycle's components are not designed to withstand. Damage caused in this way is not covered by the warranty.

Do not tamper with the control unit of the electronic

engine-management system. ◀

Checklist

Use the following checklist to check important functions, settings and wear limits before you ride off.

- Brakes
- Front and rear brake fluid levels
- Clutch
- Clutch fluid level
- Shock absorber setting and spring preload
- Tread depth and tire pressure
- Firm seating of cases and luggage

At regular intervals:

- Engine oil level (every time you refuel)
- Brake pad wear (during every third stop for refueling)

Starting

Side stand

You cannot start the motorcycle with the side stand extended and a gear engaged. The engine will switch itself off if you start it with the transmission in neutral and then engage a gear before retracting the side stand.

Transmission

You can start the engine when the transmission is in neutral or if you pull the clutch with a gear engaged. Switch on the ignition before you pull the clutch. When the transmission is in neutral, the green neutral indicator light is on and the gear indicator in the multifunction display shows 0.

Starting engine



If you switch on the ignition while the brakes are applied, then start the engine and ride off immediately, the BMW Integral ABS remains in its residual braking function mode. Self-diagnosis is performed as soon as the brake levers are in their fully released positions for the first time. During this period, neither the ABS function nor the power braking assistance is available.

When you start the engine, wait until the ABS self-diagnosis has been performed. ◀

- Switch on ignition.

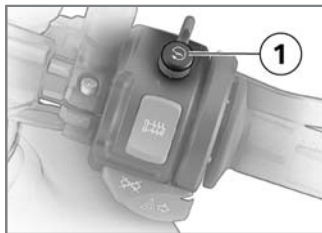
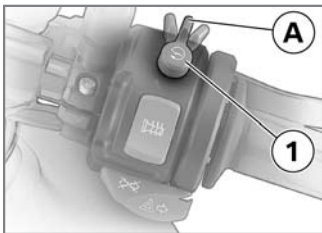

- Emergency ON/OFF switch **1** in operating position **A**.
- Switch on ignition.
 - » Pre-ride check is performed. (➡ 63)
 - » ABS self-diagnosis is performed. (➡ 64)

- Press starter button **1**.

▶ At extremely low temperatures it may be necessary to operate the throttle twist grip during starting. At ambient temperatures below 32 °F (0 °C), actuate the clutch after switching on the ignition.◀

▶ The start attempt is automatically interrupted if battery voltage is too low. Recharge the battery before you start the engine, or use jump leads and a donor battery to start.◀

- » Engine starts.
- » Consult the troubleshooting chart if the engine refuses to start. (➡ 130)

Pre-ride check

After switching on the ignition, the instrument cluster carries out a general warning light test. In the process the warning light first lights up yellow and then red for checking. This test, called a "Pre-ride check", is indicated by the lettering CHECK! in the display. If the engine is started during the test, the test is canceled.

Phase 1

 General warning light lights up yellow.

- The note CHECK! is indicated.

Phase 2



General warning light lights up red.

– The note CHECK! is indicated.

If the general warning light is not shown:



If the general warning light cannot be displayed, several malfunctions cannot be indicated. Watch the display of the general warning light in red and yellow.◀

- Have the fault rectified as soon as possible by a specialized workshop, preferably an authorized BMW motorcycle retailer.

ABS warning lights

The ABS warning light is shown in two versions depending on country:



Country version 1.



Country version 2.

The following description is made based on country version 1.

ABS self-diagnosis

The BMW Integral ABS performs self-diagnosis and a pull-away test to ensure its operability. Self-diagnosis is performed automatically when you switch on the ignition. Self-diagnosis is not performed unless both brake levers are in their fully released positions.

Phase 1

Self-diagnosis is performed.



General warning light lights up red.



ABS warning light flashes four times per second.

Phase 2

Self-diagnosis is complete.



ABS warning light flashes once per second.

If it was not possible to end self-diagnosis:

- Release the brake lever as soon as possible.

If an error message is shown after self-diagnosis is completed:

- Read the meaning of this display in the chapter "Displays".



The ABS warning light does not go out until after completion of the starting-off test.◀

Starting off

Starting on grades

- Engage gear.
- Release clutch lever and brake lever.
- Switch on ignition.
- » Pre-ride check is performed. (➡ 63)
- Wait for ABS self-diagnosis to complete.
- Operate brake and clutch.
- Starting engine.

ABS pull-away test

After starting off, the BMW Integral ABS checks the ABS sensors.



ABS warning light flashes once per second.

- » The ABS warning light goes out after completion of the pull-away test.

If an error message is shown after the pull-away test is completed:

- Read the meaning of this display in the chapter "Displays".

Running in

The first 600 miles (1,000 km)

- While running in motorcycle, vary throttle opening and engine-speed range frequently.
- Try to do most of your riding during this initial period on twisting, fairly hilly roads, avoiding high-speed main

roads and highways if possible.



Exceeding the specified engine speeds while running in will lead to increased engine wear.

Adhere to the specified engine run-in speeds. ◀

- Do not exceed engine run-in speeds.
- Engine run-in speeds 7000 min⁻¹
- Do not accelerate at full throttle.
- Avoid low engine speeds at full load.
- After 300 - 750 miles (500 - 1,200 km), have the first inspection performed.

Brake pads

New brake pads must "bed down" and therefore do not achieve their optimum friction levels during the first 300

miles (500 km). This initial reduction in braking efficiency can be compensated for by exerting greater pressure on the levers.



New brake pads can extend stopping distance by a significant margin.

Brake early.◀

Tires

New tires have a smooth surface. This must be roughened by riding in a restrained manner at various heel angles until the tires are run in. This running in procedure is essential if the tires are to achieve maximum grip.



Tires do not have their full grip when new and there is a risk of accident at extreme heeling angles.

Avoid extreme heeling angles.◀



Parking your motorcycle

Placing on side stand

 If the ground is soft or uneven, there is no guarantee that the motorcycle will rest firmly on the stand. Always check that the ground under the stand is level and firm.◀

- Switch off engine.
- Pull handbrake lever.
- Hold motorcycle upright and balanced.
- Use your left foot to extend side stand fully (arrow).

 The side stand is designed to support only the weight of the motorcycle. Do not lean or sit on the motorcycle with the side stand extended.◀

- Slowly lean motorcycle to side until its weight is taken by stand and dismount to left.

 When you prop the motorcycle on the side stand, the surface of the ground will determine whether it is better to turn the handlebars to the left or right. However, the motorcycle is more stable on a level surface with the handlebars turned to the left than with the handlebars turned to the right.

On level ground, always turn the handlebars to the left to set the steering lock.◀

- Turn handlebars to full left or right lock position.
- Check that motorcycle is standing firmly.

 On a grade, the motorcycle should always face uphill; select 1st gear.◀



Removing from side stand

- Unlock steering lock.

 Brake servo assistance is not available when the ignition is off; the motorcycle can start to roll.

Especially on inclines, switch on the ignition and wait for the ABS self-diagnosis. ◀

- Switch on ignition.
- Wait for ABS self-diagnosis to complete.
- From left, grip handlebars with both hands.
- Pull handbrake lever.
- Swing your right leg over the seat and lift the motorcycle to the upright position.
- Hold motorcycle upright and balanced.



An extended side stand can catch on the ground when the motorcycle is moving and lead to a fall.

Retract the side stand before moving the vehicle. ◀

- Sit on the motorcycle and use your left foot to retract the side stand.



Placing on center stand^{OA}

 If the ground is soft or uneven, there is no guarantee that the motorcycle will rest firmly on the stand. Always check that the ground under the stand is level and firm.◀

- Switch off engine.
- Dismount and keep left hand on left handlebar grip.
- With your right hand, take hold of the passenger grab handle or rear frame.
- Place right foot on extended arm of center stand, and press stand down until its curved feet touch ground.
- Place full weight of body on center stand while pulling motorcycle toward rear (arrow).

 Excessive movements could result in the center stand retracting, and the motorcycle would topple as a result.

Do not sit on the motorcycle while it is resting on the center stand.◀

- Check that motorcycle is standing firmly.

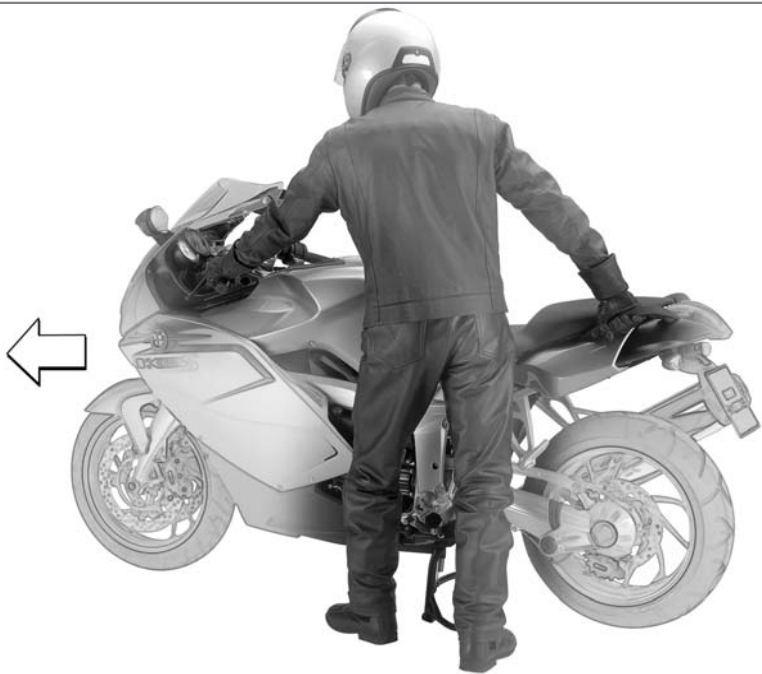

Pushing off center stand^{OA}



Brake servo assistance is not available when the ignition is off; the motorcycle can start to roll.

Especially on inclines, switch on the ignition and wait for the ABS self-diagnosis.◀

- Switch on ignition.
- Wait for ABS self-diagnosis to complete.
- Place your left hand on the left handlebar grip.
- With your right hand, take hold of the passenger grab handle.
- Push motorcycle forward off center stand.
- Make sure that center stand is fully retracted.

Refueling

! Fuel is highly flammable. Fire at the fuel tank can result in fire and explosion. Do not smoke. Never bring a naked flame near the fuel tank. ◀

! Fuel expands when exposed to heat. When the tank is overfilled, fuel can escape and get onto the rear wheel. This results in a danger of falling. Do not fill the tank past the bottom edge of the filler neck. ◀

! Fuel attacks plastic surfaces, making them dull or unsightly. Wipe spilled fuel off plastic parts immediately. ◀

! Leaded fuel will destroy the catalytic converter! Use only unleaded fuel. ◀

- Make sure the ground is level and firm and park the motorcycle.

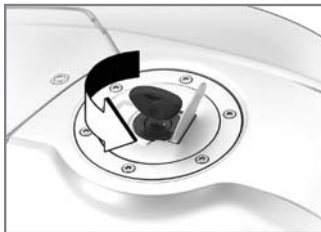

- Open protective cap.
- Open fuel tank cap with ignition key by turning counterclockwise.
- Fill tank with fuel of quality listed below.
 - Recommended fuel type
 - Premium grade unleaded fuel
 - 98 ROZ
 - Fuel types can be used with poorer performance and consumption

- Super unleaded
- 95 ROZ
- Usable fuel quantity 5 gal
- Reserve fuel quantity 1.1 gal

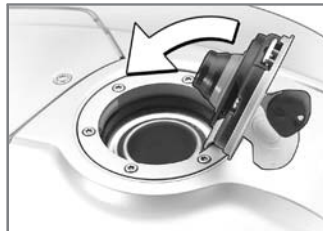

- Close fuel tank cap with firm pressure.
- Remove key and close protective cap.

General brake system

Descending mountain passes

 There is a danger of the brakes fading if you use only the rear brakes when descending mountain passes. Under extreme conditions, the brakes could overheat and suffer severe damage. Use both front and rear brakes, and make use of the engine's braking effect as well. ◀

Wet brakes

 After the motorcycle has been washed, ridden through water or ridden in the rain, the brake disks and pads might be wet and the brakes might not take effect immediately. Brake early until the brakes are dry or braked until dry. ◀

Salt on brakes

 The full braking effect can be delayed if the motorcycle is ridden on salt-covered roads and the brakes are not applied for some time. Brake early until the salt layer of the brake disks and brake pads has been braked off. ◀

Oil or grease on brakes

 Oil and grease on the brake disks and pads considerably diminish braking efficiency. Especially after repair and maintenance tasks, make sure that the brake discs and brake pads are free of oil and grease. ◀

Dirt or mud on brakes

 When the motorcycle is ridden on loose surfaces or muddy roads, the brakes may fail to take effect immediately because of dirt or moisture on the disks or brake pads. Brake early until the brakes are braked clean. ◀

Brake system with BMW Integral ABS

Sensitive electronic control

It takes skill and sensitive control of the brakes to stop safely on a motorcycle. If the front brakes lock and the wheel skids, the necessary longitudinal and lateral stabilizing forces are lost, and a fall can result. For this reason, the rider seldom makes full use of available braking

performance in an emergency.

The BMW Integral ABS provides improved braking deceleration by means of lock up protection for both wheels and braking force distribution by means of the integral braking function. Making full use of the motorcycle's technical braking capacity will minimize braking distances noticeably, even when road conditions are poor. When driving straight ahead, BMW Integral ABS enables safe, reliable braking optimized for the respective conditions.

Reserves for safety

But remember: the potentially shorter braking distances which BMW Integral ABS permits must not be used as an excuse for careless riding. ABS is primarily a means of

ensuring a safety margin in genuine emergencies.

Take care when cornering. When you apply the brakes on a corner, the motorcycle's weight and momentum take over and even BMW Integral ABS is unable to counteract their effects.

Partially integral brake

Your motorcycle is equipped with a partially integral brake configuration. Both front and rear brakes are applied simultaneously when you pull the handbrake lever. The foot-brake lever acts only on the rear brake.

The electronic controller in the BMW Integral ABS regulates braking-force distribution between front and rear wheels. Braking-force distribution depends on load and is recalculated every time the

ABS controller comes into action.

Brake booster

On braking, BMW Integral ABS boosts the brake force on the wheel by means of a hydraulic pump. By boosting the braking force in this way, BMW Integral ABS achieves higher braking efficiency than standard brake systems.

ABS anti-lock braking system

ABS prevents the wheels locking under braking, thus contributing significantly to road safety.

Rear wheel lift

Even under severe braking, a high level of tire grip can mean that the front wheel does not lock up until very late, if at all. Consequently,

ABS does not intervene until very late, if at all. Under these circumstances the rear wheel can lift off the ground, and the outcome can be a highside situation in which the motorcycle can flip over.

 Severe braking can cause the rear wheel to lift off the ground.

Bear in mind that ABS cannot be relied on in all circumstances to prevent the rear wheel from lifting clear of the ground.◀

Residual braking function

With the ignition switched off, during the self-diagnosis and in the event of a fault in the BMW Integral ABS, the brake circuits concerned only have the residual braking function. The residual braking function is the braking power with-

out the hydraulic servo assistance of the BMW Integral ABS. Under these circumstances, therefore, you must apply considerably higher pressure to the brake levers in question in order to apply the brakes, and lever travel is longer. When the residual braking function is active, the ABS function is unavailable in the brake system in question. When the residual braking function is active, the integral braking function is partially or entirely unavailable.

 Without the ABS function, the wheels could lock during very hard braking. Without servo-assisted brakes, considerably greater force is required to brake. The altered braking behavior can lead to accidents. Avoid hard braking whenever

possible. Brake early, as increased braking force is required.

Have the fault rectified as soon as possible by a specialized workshop, preferably an authorized BMW motorcycle retailer.◀

 As the residual braking function means that the lever path before the brake pressure is built up can be longer, BMW Motorrad recommends that a larger lever path be set at the handbrake lever.◀

 In the case of residual braking function in both brake circuits, no pump noise can be heard when the brake lever is operated.◀

Accessories

General instructions	82
Onboard socket	82
Luggage	85
Case ^{OA}	86
Flat tire kit ^{OA}	89

General instructions

BMW Motorrad recommends the use of parts and accessories for your motorcycle that are approved by BMW for this purpose.

Genuine BMW parts and accessories and other products which BMW has approved can be obtained from your authorized BMW motorcycle retailer, together with expert advice on their installation and use.

These parts and products have been tested by BMW for safety, function and suitability. BMW accepts product liability for these products.

Conversely, BMW is unable to accept any liability whatsoever for parts and accessories which it has not approved.



BMW cannot evaluate whether every product of other manufacturers is suitable for use on BMW motorcycles without presenting a safety risk. Nor is this guarantee provided when the official approval of a specific country has been granted. Tests conducted by these instances cannot make provision for all operating conditions experienced by BMW motorcycles and, consequently, they are not sufficient in some circumstances.

Use only parts and accessories approved by BMW for your motorcycle. ◀

Whenever you are planning modifications, comply with all the legal requirements. The motorcycle must not infringe on national road-vehicle construction and use regulations.

Onboard socket Ratings

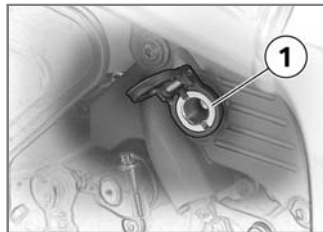

The supply to the socket **1** is cut off automatically if battery voltage is low or the load exceeds the maximum rating of 5 A.

Operating electrical accessories

You can start using electrical accessories only when the ignition is switched on. The accessory remains operational if the ignition is subsequently switched off. Approx.

15 minutes after switching off the ignition and/or during the restart operation, the on-board socket is switched off to take the load off the vehicle electrical system.

Cable routing

The cables from the onboard socket to the auxiliary device must be routed in such a way that they:

- Do not impede the rider
- Do not restrict or obstruct the steering angle and handling characteristics
- Cannot be trapped



Improperly routed cables can impede the rider.

Route the cables as described above. ◀

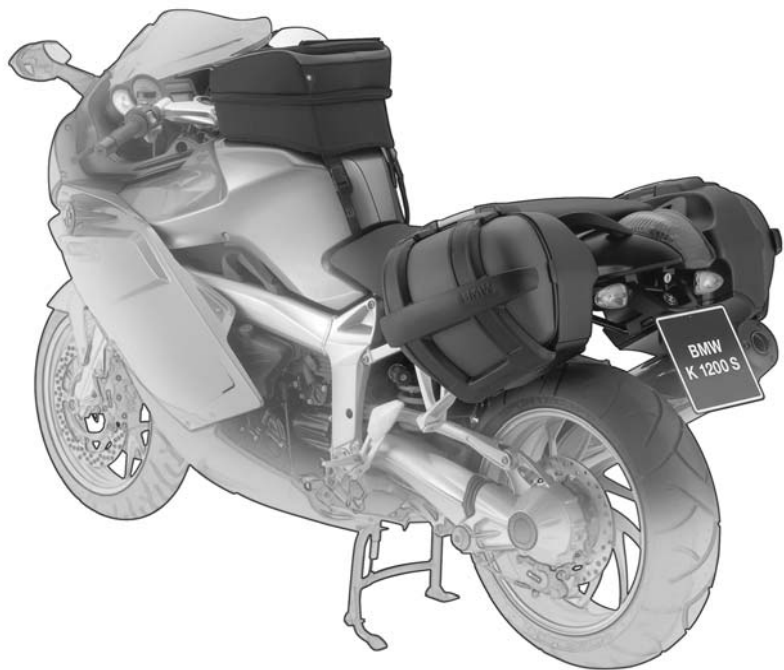

Luggage

Correct loading

 Overloading and uneven loading can diminish the riding stability of the motorcycle.

Do not exceed the gross weight limit and observe the loading information. ◀

- Max. load in tank rucksack
11 lbs (5 kg).
- Adjust setting of spring preload, damping characteristic and tire pressures to suit total weight.
- Ensure that the case volumes on the left and right are equal.
- Make sure weight is uniformly distributed between right and left.
- Pack heavy items of luggage downwards and inwards.
- Max. load in each case (left and right): 18 lbs (8 kg).

Case^{OA}

Release levers

There is a release lever on the left and right of each case lock.

The gray lever marked OPEN is used to open and close the cases.

The black lever marked RELEASE is used to remove and attach the cases.

Opening case

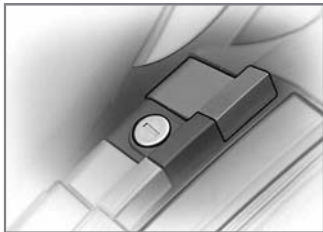

- Turn lock barrel vertical to driving direction.
- » Case can be opened.

- Cases secured.
- Key can be removed.



- Pull gray release lever (OPEN) upward.
- » Lock straps **1** open.
- Pull gray release lever (OPEN) upward again.
- Pull case lid **2** out of retainer.
- » Case completely opened.

Closing case

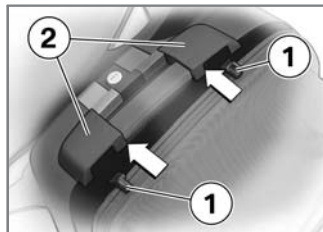

- Press catches **1** of case lid into the retainers **2**.
- » The catches can be heard to lock into place.
- Close the lock straps.

Adjusting case volume

- Close case lid.

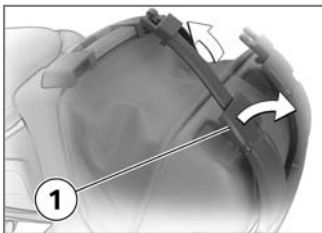

- Turn lock strap buckles **1** of lock straps outward.
- Pull out the lock straps upwards.
 - » The maximum volume has been set.



- Close the lock straps.
- Press the lock straps against the case body.
 - » The case volume is adapted to the contents.

Removing case

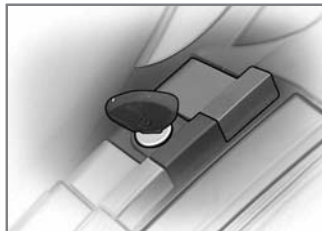

- Turn case lock 45° relative to driving direction.
 - » Key cannot be removed.
 - Cases locked.
 - Cases can be removed.
- Pull black release lever (RELEASE) upward.

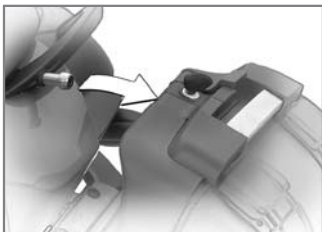

- Pull the case out of the upper mounting.
- Lift the case out of the lower mounting.

Mounting case

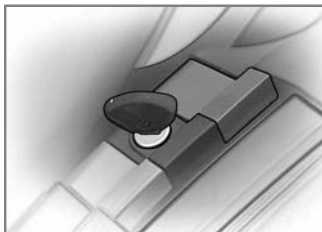

- Turn case lock 45° relative to driving direction.
 - » Key cannot be removed.
 - Cases locked.

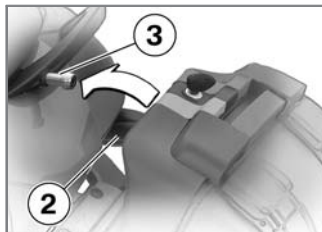

- Hook case into lower mounting **2**.
- Pull black release lever (RELEASE) upward.
- Press case into upper mounting **3**.
- Press black release lever (RELEASE) downward.
 - » The case is locked into place.
- Lock case.
- Check secure locking.

Secure hold



If a case wobbles or is difficult to fit, it has to be adapted to the gap between the upper and lower mounting. To achieve this, the height of the lower bracket on the case can be changed.

Adapting case

- Open case.

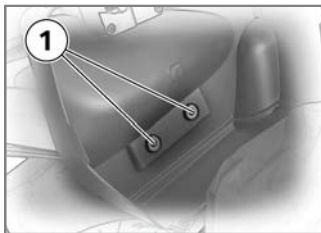

- Unfasten screws **1**.
- Adjust height of bracket.
- Tighten screws **1**.

Flat tire kit^{OA}

Use

The space for the flat tire kit is located under the left-hand side panel.

The repair procedure and safety precautions are contained in the description included with in the flat tire kit.

Removing flat tire kit

- Make sure the ground is level and firm and park the motorcycle.
- Removing seat (→ 50)

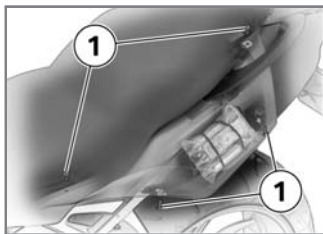

- Remove screws **1**.
- Removing side panel.

▶ To protect the side panel from scratches, lay it on the seat.◀

- Open the securing strap and remove the flat tire kit.

Maintenance

Maintenance - General Information	92
Toolkit	92
Contents of supplemental set ^{OA}	92
Overview of supplemental set	92
Engine oil	92
General brake system	94
Brake pads	95
Brake fluid	97
Clutch	100
Tires	100
Rims	101
Wheels	101
Front wheel stand	108

Rear-wheel stand	110
Lamps	111
Jump starting	117
Battery	119

Maintenance - General Information

The 'Maintenance' chapter describes work involving the replacement of wear parts that can be performed with a minimum of effort.

If special tightening torques are to be taken into account for assembly, these are also listed.

Screw connections for which there is a matching tool in the onboard toolkit are marked.

If you are interested in information on additional work, we recommend the Repair Manual for your motorcycle on CD-ROM. This is available from your authorized BMW motorcycle retailer.

Toolkit

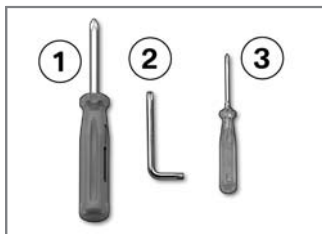

- 1 Reversible screwdriver
- 2 Torx wrench T25
- 3 Screwdriver, small

 The included toolkit is located under the seat.

Contents of supplemental set^{OA}

The supplemental set is available as an optional accessory. Please contact your authorized BMW motorcycle retailer.

Overview of supplemental set

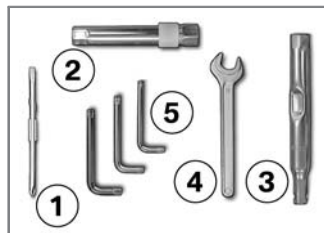

- 1 Screwdriver blade
- 2 Socket wrench, 17
- 3 Spark plug socket wrench
- 4 17 mm open-end wrench
- 5 TORX wrench T40, T45, T50

Engine oil

Checking engine oil level



The engine can seize if the oil level is low, and this can lead to accidents.

Always make sure that the oil level is correct. ◀

 After longer motorcycle immobilization periods, engine oil can collect in the oil pan; this must be pumped into the oil tank before the reading is taken. Here, the engine oil must be at operating temperature. Checking the oil level with the engine cold or after a short trip leads to misinterpretations and therefore to incorrect oil fill quantities.

To ensure that the display of the engine oil level is correct, only check the oil level after a longer trip. ◀

 The oil level varies with the temperature of the oil. The higher the temperature the higher the oil level in the oil tank. Check the engine

oil level immediately after a longer journey. ◀

- Make sure the ground is level and firm and hold the motorcycle at operating temperature vertically with OA Center stand:
- Make sure ground is level and firm and place motorcycle at operating temperature on its center stand.
- Let the engine run in neutral for one minute.
- Switch off ignition.

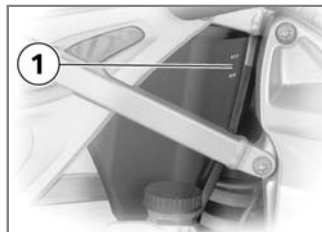

- Read off the oil level from the display **1**.



- Specified level of engine oil Between MIN and MAX marking

If oil level is below MIN mark:

- Top up engine oil.

If oil level is above MAX mark:

- Drain off engine oil.

Topping up engine oil

- Make sure the ground is level and firm and park the motorcycle.
- Removing seat (➔ 50)

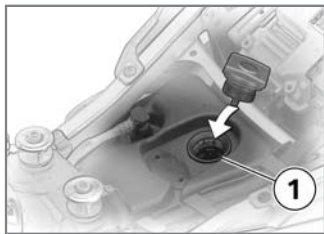

! Both too little and too much engine oil can lead to engine damage. Always make sure that the oil level is correct. ◀

- Wipe area around filler neck clean.
- Unscrew cap of fill opening for engine oil **1**.
- Add engine oil up to specified level.

Draining engine oil

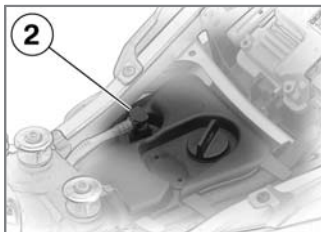

- Press retainer of clear hose **2** on left and right and pull out of oil tank upwards.
- Pull clear hose downward out of frame and drain engine oil into a suitable container until specified level is reached.

- Insert the clear hose in the oil tank and lock into place.
- Store or dispose of excess engine oil in line with sound environmental principles.

General brake system

Operating safety

A properly functioning brake system is a basic requirement for the road safety of your motorcycle.

Do not ride the motorcycle if you have any doubts about the dependability of the brake system.

In this case, have the brake system checked by a certified workshop, preferably by an authorized BMW motorcycle retailer.

 Incorrect working practices endanger the reliability of the brakes.

Have all work on the brake system performed by a certified workshop, preferably by an authorized BMW motorcycle retailer. ◀

Checking brake operation

- Switch on ignition.
- Wait for ABS self-diagnosis to complete.
- Pull handbrake lever.
 - » Pressure point must be clearly perceptible.
 - » Hydraulic pump must be heard to run.
- Press footbrake lever.
 - » Pressure point must be clearly perceptible.
 - » Hydraulic pump must be heard to run.

with OE Elimination of BMW Motorrad Integral ABS:

- Pull handbrake lever.
 - » Pressure point must be clearly perceptible.
- Press footbrake lever.
 - » Pressure point must be clearly perceptible.

Brake pads

Checking front brake pad thickness

 Continuing to use brake pads beyond the minimum pad thickness leads to reduced braking power and under certain circumstances to brake damage.

In order to ensure the operating reliability of the brake system, make sure that the brake pads are not worn beyond their minimum thickness. ◀

- Make sure the ground is level and firm and park the motorcycle.



- Visually inspect left and right brake pads to ascertain their thickness.

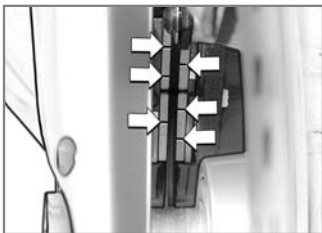

- Front brake pad thickness
The brake pads must have a clearly visible wear indicating mark.

If the wear indicating mark is no longer clearly visible:

- Have brake pads replaced by a specialized workshop, preferably an authorized BMW motorcycle retailer.

Checking brake pad thickness at rear

 Continuing to use brake pads beyond the minimum pad thickness leads to reduced braking power and under certain circumstances to brake damage.

In order to ensure the operating reliability of the brake system, make sure that the brake pads are not worn beyond their minimum thickness. ◀

- Make sure the ground is level and firm and park the motorcycle.

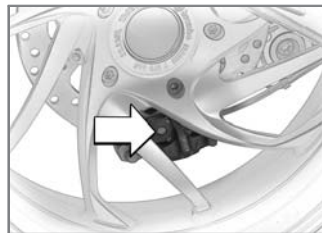

- Perform a visual inspection of the brake pad thickness from the right.



- Rear brake pad thickness

Brake disk must not be visible through bore **1** hole of inner brake pad.

If the brake disk is visible:

- Have brake pads replaced by a specialized workshop, preferably an authorized BMW motorcycle retailer.

Brake fluid

Checking front brake fluid level

 A low fluid level in the brake reservoir can allow air to penetrate the brake system. This significantly reduces braking efficiency. Brake early. ◀

- Make sure the ground is level and firm and hold the motorcycle vertically.
- Move handlebars into straight-ahead position.

with OA Center stand:

- Make sure ground is level and firm and place motorcycle on its center stand.
- Move handlebars into straight-ahead position.

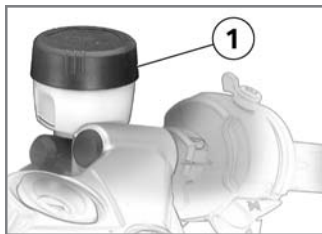

- Read off the brake fluid level at the reservoir **1**.

 The brake fluid level in the brake-fluid reservoir does not drop due to brake pad wear. ◀



- Front brake fluid level
Brake fluid DOT4
Brake fluid level must not drop.

If the brake fluid level falls - even above the MIN mark - this indicates a defect in the brake system.

- Have fault remedied as quickly as possible by a certified workshop, preferably an authorized BMW motorcycle retailer.

with OE Elimination of BMW Motorrad Integral ABS:

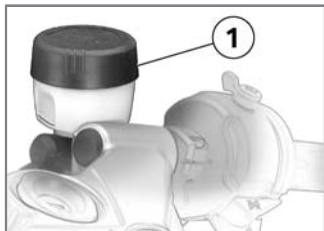

- Read off the brake fluid level at the reservoir **1**.

▷ In the event of brake pad wear, the brake fluid level in the brake-fluid reservoir falls. ◀



- Front brake fluid level with OE Elimination of BMW Motorrad Integral ABS: Brake fluid DOT4
Brake fluid level must not fall below MIN mark.

If brake fluid level drops below permissible level:

- Have fault remedied as quickly as possible by a certified workshop, preferably an authorized BMW motorcycle retailer.

Checking rear brake fluid level

 A low fluid level in the brake reservoir can allow air to penetrate the brake system. This significantly reduces braking efficiency. Brake early. ◀

- Make sure the ground is level and firm and park the motorcycle.



- Read off the brake fluid level at the reservoir **1**.

▶ The brake fluid level in the brake-fluid reservoir does not drop due to brake pad wear.◀



– Rear brake fluid level
Brake fluid DOT4
Brake fluid level must not drop.

If the brake fluid level falls - even above the MIN mark - this indicates a fault in the brake system.

- Have fault remedied as quickly as possible by a certified workshop,

preferably an authorized BMW motorcycle retailer.

with OE Elimination of BMW Motorrad Integral ABS:



- Read off the brake fluid level at the reservoir **1**.

▶ In the event of brake pad wear, the brake fluid level in the brake-fluid reservoir falls.◀



- Rear brake fluid level with OE Elimination of BMW Motorrad Integral ABS:
Brake fluid DOT4
Brake fluid level must not fall below MIN mark.

If brake fluid level drops below permissible level:

- Have fault remedied as quickly as possible by a certified workshop, preferably an authorized BMW motorcycle retailer.

Clutch

Checking clutch operation

- Pull clutch lever.
 - » Pressure point must be clearly perceptible.
- If no clear pressure point can be felt:

- Have clutch checked by a specialized workshop, preferably an authorized BMW motorcycle retailer.

Checking clutch fluid level

- Make sure the ground is level and firm and hold the motorcycle vertically.
 - Move handlebars into straight-ahead position.
- with OA Center stand:
- Make sure ground is level and firm and place motorcycle on its center stand.

- Move handlebars into straight-ahead position.

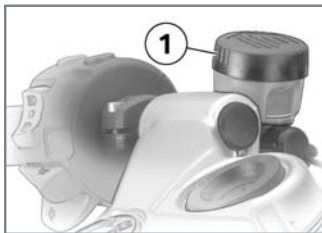

- Read off clutch fluid level at reservoir **1**.



– Clutch fluid level

Clutch fluid level must not drop.

If fluid level drops:

⚠ Unsuitable hydraulic fluids could cause damage to the clutch system.

No fluids may be poured in. ◀

- Have fault remedied as quickly as possible by a certified workshop, preferably an authorized BMW motorcycle retailer.

▶ The clutch system is filled with a special hydraulic fluid that does not require changing. ◀

Tires

Checking tire tread depth

⚠ Your motorcycle's handling and grip can be impaired even before the

tires wear to the minimum tire tread depth permitted by law. Have the tires changed in good time before they wear to the minimum permissible tread depth.◀

- Make sure the ground is level and firm and park the motorcycle.
- Measure tire tread depth in main tread grooves with wear indicating marks.

 Tires have wear indicators integrated into the main tread grooves. If the tire tread has worn down to the level of the marks, the tire is completely worn. The locations of the marks are indicated on the edge of the tire, e.g. by the letters TI, TWI or by an arrow.◀

If tire tread depth no longer complies with legally required minimum tread depth:

- Replace tire.

Rims

Checking rims

- Make sure the ground is level and firm and park the motorcycle.
- Visually inspect rims for defects.
- Have damaged rims checked and, if necessary, replaced by a specialized workshop, preferably an authorized BMW motorcycle retailer.

Wheels

Approved wheels and tires

For each size of tire BMW Motorrad tests certain makes, and approves those that it certifies as roadworthy. If BMW Motorrad has not approved the wheels and tires, it cannot assess their suitability or provide any guarantee of road safety.

Use only wheels and tires approved by BMW Motorrad for your type of motorcycle. You can obtain detailed information from your authorized BMW motorcycle retailer or on the Internet at www.bmw-motorrad.com.

Removing front wheel

- Place motorcycle on an auxiliary stand; BMW Motor-

rad recommends the BMW Motorrad rear wheel stand.

- Install rear-wheel stand with OA Center stand:
- Make sure ground is level and firm and place motorcycle on its center stand.

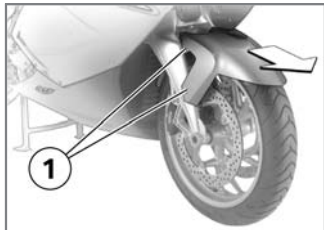

- Remove screws **1** on left and right.
- Pull out the front wheel mudguard towards the front.

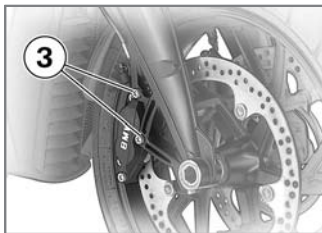

! Once the calipers have been removed, there is a risk of the brake pads being pressed together to the extent that they cannot be slipped back over the brake disk on reassembly. Do not operate the handbrake lever when the brake calipers have been removed. ◀

- Remove mounting bolts **3** of brake calipers on left and right.

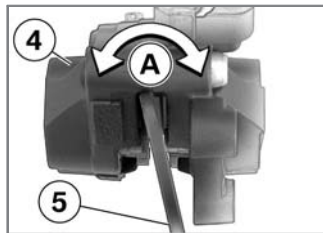

- Press brake pads in brake caliper **4** somewhat apart with rotary movements **A** against brake disks **5**.
- Mask off area of wheel rim that could be scratched in process of removing brake calipers.
- Carefully pull brake calipers back and out until clear of brake disks.
- When pulling off left brake caliper, make sure that ABS sensor cable is not damaged.
- Raise front of motorcycle until front wheel can rotate

- freely. To raise motorcycle, it is advisable to use BMW Motorrad front wheel stand.
- Mounting front wheel stand (→ 109)

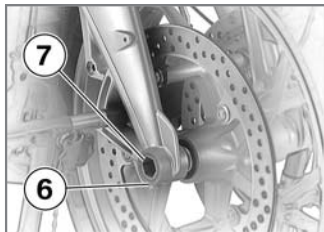

! The left axle clamping screw fixes the threaded bush in place in the front suspension. A poorly aligned threaded bush results in incorrect spacing between the ABS sensor ring and the ABS sensor, and therefore to ABS malfunctions or destruction of the ABS sensor. To ensure the proper align-

ment of the threaded bush, do not loosen or remove the left axle clamping screw. ◀

- Remove right-hand axle clamping screw **6**.
- Remove quick-release axle **7**, holding wheel as you do so.

▶ BMW Motorrad offers an adapter for removing the quick-release axle. This adapter can be combined with a commercially available 22 mm open-end or ring wrench. The adapter with BMW special tool number 36 3 691 can be obtained from your authorized BMW motorcycle retailer. ◀



- Place the front wheel in the front wheel guide on the ground.
- Roll front wheel forward to remove.

▶ When rolling out/rolling in the front wheel, be careful not to damage the ABS sensor. ◀

Installing front wheel

! Threaded fasteners not tightened to the specified torque can work loose or their threads can suffer damage.

Always have the security of the fasteners checked by a specialized workshop, preferably an authorized BMW motorcycle retailer. ◀

! During the following work, parts of the front brake, in particular of the BMW Integral ABS, can be damaged.

Take care not to damage the brake system, in particular the ABS sensor with cable and the ABS sensor ring. ◀

! The front wheel must be installed right way round to rotate in the correct direction.

Observe the direction of rotation arrows on the tires or on the rim. ◀

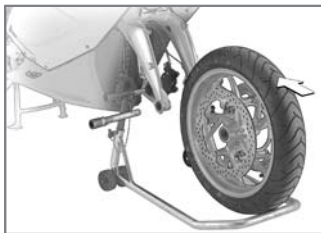

- Roll front wheel into front wheel guide.

 When rolling out/rolling in the front wheel, be careful not to damage the ABS sensor. ◀

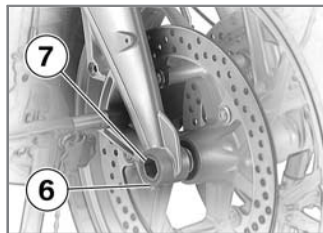

- Raise the front wheel, install the quick-release axle **7** and tighten with the appropriate tightening torque.
- Quick-release axle in threaded bush
37 lb/ft
- Tighten the right-hand axle clamping screw **6** with the appropriate tightening torque.
- Clamping screw on quick-release axle in wheel carrier
14 lb/ft
- Remove front wheel stand.

- Ease brake calipers on to brake disks.

⚠ The cable of the ABS sensor could chafe through if it comes into contact with the brake disk. Make sure that ABS sensor cable is routed correctly. ◀

- Carefully route ABS cable.

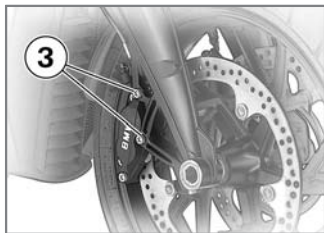

- Install mounting screws **3**.
- Front brake caliper mounted on wheel carrier (➔ 131)
- Remove adhesive tape from wheel rim.

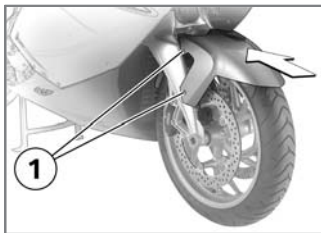

- Install front mudguard and screws **1** and tighten.
- Switch on ignition.
- Wait for ABS self-diagnosis to complete.
- Press the handbrake lever firmly a number of times until the resistance point is noticeable.

Removing rear wheel

- Place motorcycle on an auxiliary stand; BMW Motorrad recommends the BMW Motorrad rear wheel stand.
- Install rear-wheel stand with OA Center stand:
- Make sure ground is level and firm and place motorcycle on its center stand.

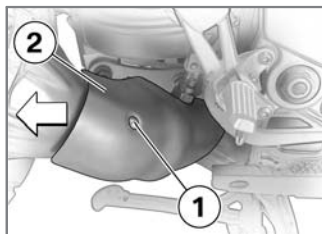

- Remove bolt **1** of muffler cover **2**.
- Pull cover towards rear.

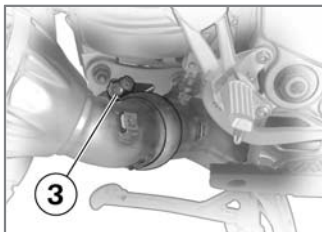

- Remove clamp **3** on muffler.
- Do not remove sealing grease from clamp.



- Remove bolt **4** of end muffler bracket on rear footrest.
- Turn end muffler out.

- Engage first gear.

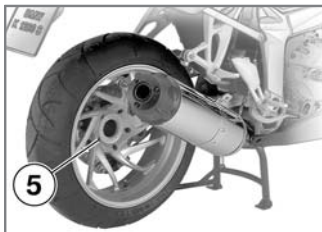

- Remove mounting bolts **5** of rear wheel, holding wheel as you do so.
- When using the BMW Motorrad rear wheel stand: remove the lock washer.

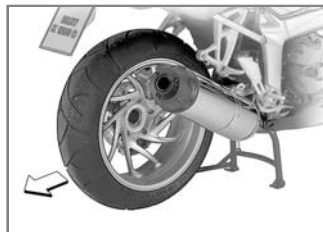

- Lower the rear wheel to the ground.
- Roll rear wheel out toward rear.
- When using the BMW Motorrad rear wheel stand: re-mount the lock washer.

Installing rear wheel

 Threaded fasteners not tightened to the specified torque can work loose or their threads can suffer damage.

Always have the security of the fasteners checked by a specialized workshop, prefer-

ably an authorized BMW motorcycle retailer. ◀

- When using the BMW Motorrad rear wheel stand: remove the lock washer.

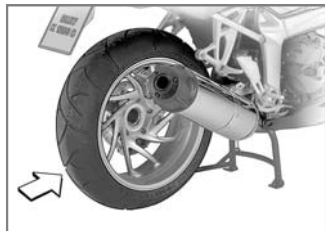

- Roll the rear wheel onto the rear wheel support.
- Place the rear wheel on the rear wheel support.
- When using the BMW Motorrad rear wheel stand: re-mount the lock washer.

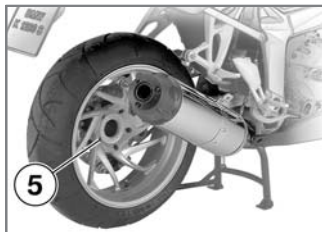

- Mount wheel bolts **5** and tighten diagonally with appropriate tightening torque.
 - Rear wheel on wheel flange 44 lb/ft
- Turn the end muffler to its initial position.



- Install screw **4** for end muffler bracket in rear footrest, but do not tighten it at this point.

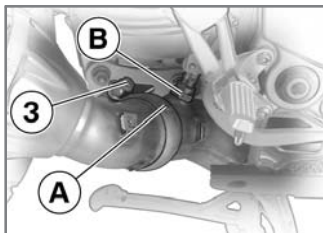

- Align clamp **3** on end muffler with marking **A** (arrow) on lambda probe **B**.
- Tighten clamp **3** on end muffler.
- Muffler on manifold (➔ 131)

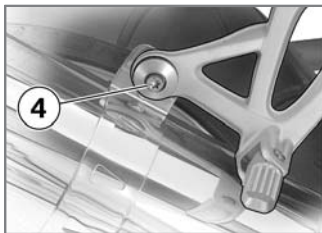

- !** If the gap between the rear wheel and the end muffler is too small, the rear wheel can overheat. The gap between the rear wheel and the end muffler must be at least 0.59 in. ◀
- Install bolt **4** of end muffler bracket on rear footrest.
 - Muffler on right passenger footrest
21 lb/ft

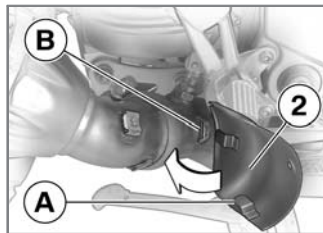

- Push muffler cover **2** with guides **A** into brackets **B**.
- Remove auxiliary stand if mounted.

Front wheel stand

Front wheel stand

A front wheel stand for simple, safe changing of the front wheel is available from BMW Motorrad. The BMW special tool number is 36 3 971 and the front wheel stand is available from your authorized BMW motorcycle retailer. You also need the

adapters with the BMW special tool number 36 3 973.

 The BMW Motorrad front wheel stand is not designed for holding motorcycles without a center or other auxiliary stands. A motorcycle standing on the front wheel stand and the rear wheel alone can fall over. Place the motorcycle on the center stand or an auxiliary stand before lifting it with the BMW Motorrad front wheel stand. ◀

Mounting front wheel stand

- Place motorcycle on an auxiliary stand; BMW Motorrad recommends the BMW Motorrad rear wheel stand.
- Install rear-wheel stand.

with OA Center stand:

- Make sure ground is level and firm and place motorcycle on its center stand.



- Loosen adjusting screws **1**.
- Push two mounting pins **2** far enough apart that front suspension fits between them.
- Use locating pins **3** to set front wheel stand to desired height.
- Center front wheel stand relative to front wheel and push it against front axle.

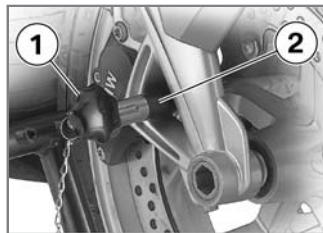

- Push two mounting pins **2** through triangles of brake caliper support toward inside so that front wheel can still be rolled through.

 In the case of BMW Integral ABS, the ABS sensor ring can be damaged. Only push the mounting pin so far inward that it does not touch the sensor ring of the BMW Integral ABS. ◀

- Tighten adjusting screws **1**.



! If the motorcycle is resting on the center stand: The motorcycle is raised too far at the front, the center stand lifts off the ground and the motorcycle can tip over to the side.

When raising the motorcycle, make sure that the center stand remains on the ground. ◀

- Apply uniform pressure to push front wheel stand down and raise motorcycle.

Rear-wheel stand

Rear-wheel stand

In order to be able to work safely on motorcycles without center stands, BMW Motorrad offers a rear wheel stand. The BMW special tool number is 36 3 980 and the rear wheel stand are available from your authorized BMW motorcycle retailer.

Installing rear-wheel stand

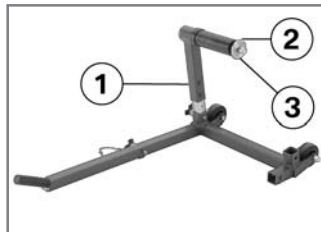

- Set the desired height of the rear wheel stand using the bolts **1**.
- Remove the lock washer **2**; to do so, press the unlock button **3**.

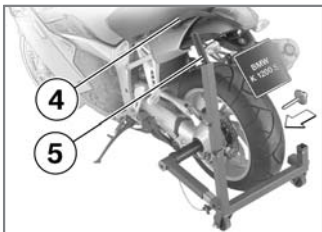

- Push the rear wheel stand from the left into the rear axle.
- Apply the retaining disk from the right; to do so, press the unlock button.
- Place your left hand on the left grab handle of the motorcycle **4** and your right hand on the lever of the rear wheel stand **5**.

- Raise the motorcycle, simultaneously pressing the lever downwards until the motorcycle stands vertically.

- Press the lever onto the ground.

Lamps

General instructions

The failure of a bulb is signaled in the display by the lamp defect symbol. If the brake or rear light fails, the general warning light also lights up in yellow. If the rear light fails, the brake light is used as a substitute in that the luminosity of the second glow filament is reduced to rear light level. Failure of the rear light is nevertheless indicated in the display.

 A defective bulb places your safety at risk because it is easier for other users to oversee you and your motorcycle.

Replace defective bulbs as soon as possible; always carry a complete set of spare bulbs if possible. ◀

! The bulb is pressurized and can cause injury if damaged.

Wear eye and hand protection when replacing bulbs.◀

▷ An overview of the bulb types installed in your motorcycle is provided in the chapter "Technical Data".◀

▷ Do not touch the glass of new bulbs with your fingers. For installation, use a clean, dry cloth. Dirt deposits, in particular oil and grease, interfere with heat radiation from the bulb. Overheating and therefore short service life of the bulbs are the consequence.◀

Replacing low-beam bulb

! If it is not standing firmly, the motorcycle could

topple in the course of the operations described below. Make sure that the motorcycle is steady on its stand.◀

▷ To achieve better accessibility, turn the handlebars to the left.◀

- Make sure the ground is level and firm and park the motorcycle.
- Switch off ignition.

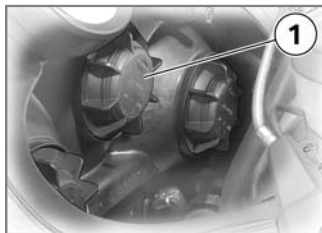

- Release cover **1** by turning counterclockwise and remove it.



- Disconnect plug **2**.



- Remove spring wire brackets **3** from their detents on left and right and fold them up.

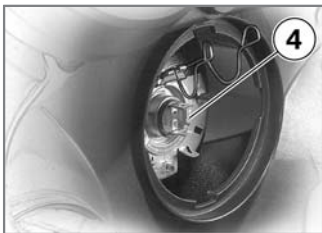



- Remove bulb **4**.
- Install bulb in reverse order.
- Use a clean, dry cloth to hold new bulb.



- When assembling, make sure that lug **5** points upwards.

Replacing high-beam bulb

 If it is not standing firmly, the motorcycle could topple in the course of the operations described below. Make sure that the motorcycle is steady on its stand.◀

 To achieve better accessibility, turn the handlebars to the left.◀

- Make sure the ground is level and firm and park the motorcycle.
- Switch off ignition.

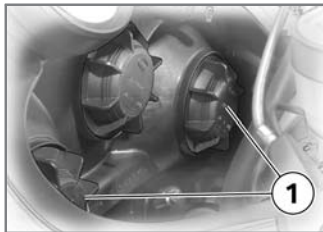

- Release cover **1** by turning counterclockwise and remove it.



- Disconnect plug **2**.



- Remove spring wire brackets **3** from their detents on left and right and fold them up.

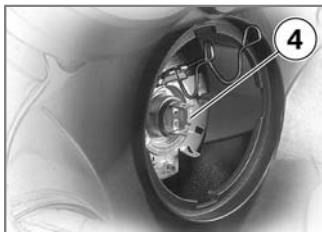

- Remove bulb **4**.
- Install bulb in reverse order.
- Use a clean, dry cloth to hold new bulb.



- On assembly, make sure that lug **5** points upwards.

Position in headlight



The side-light bulb **1** is accessible via **2**.

Replacing side-light bulb

 If it is not standing firmly, the motorcycle could topple in the course of the operations described below. Make sure that the motorcycle is steady on its stand. ◀

- Make sure the ground is level and firm and park the motorcycle.
- Switch off ignition.

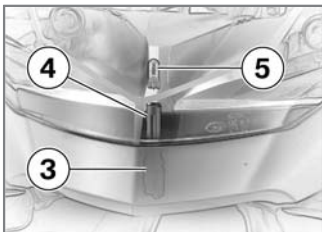

topple in the course of the operations described below. Make sure that the motorcycle is steady on its stand. ◀

- Make sure the ground is level and firm and park the motorcycle.
- Removing seat (→ 50)
- Switch off ignition.

- Pull off connector **3** beneath headlight.
- Remove bulb holder **4** from headlight housing by turning it counterclockwise.
- Twist bulb **5** out of bulb holder.
- Install bulb in reverse order.
- Use a clean, dry cloth to hold new bulb.

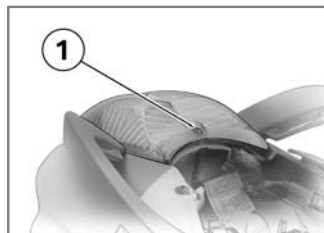

- Remove the screw **1**.

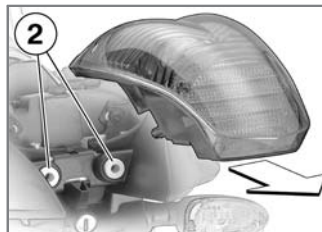

- Pull bulb housing toward rear until it is clear of holders **2**.



- Turn bulb holder **3** counterclockwise to remove it from bulb housing.

Replacing brake light and rear light bulbs



If it is not standing firmly, the motorcycle could

- Press bulb into its socket and turn it counterclockwise to remove.
- Install brake and tail light in reverse order.
- Use a clean, dry cloth to hold new bulb.

Replacing front turn indicator bulb

! If it is not standing firmly, the motorcycle could topple in the course of the operations described below. Make sure that the motorcycle is steady on its stand. ◀

- Make sure the ground is level and firm and park the motorcycle.
- Switch off ignition.

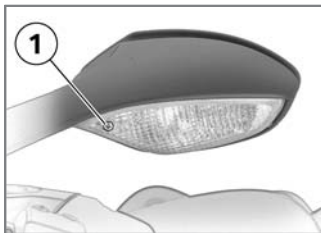

- Remove the screw **1**.

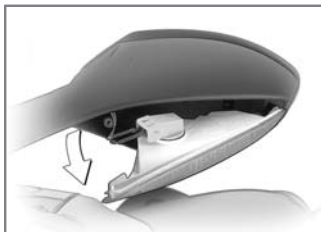

- Pull the lamp housing on the screw connection side out of the mirror housing.

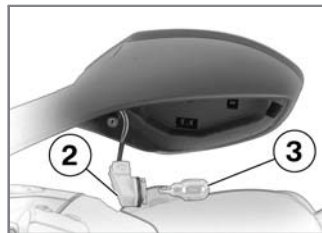

- Remove bulb holder **2** from lamp housing by turning it counterclockwise.
- Remove bulb **3** from bulb holder.
- Install bulb in reverse order.
- Use a clean, dry cloth to hold new bulb.

Replacing rear turn indicator bulb

! If it is not standing firmly, the motorcycle could topple in the course of the operations described below.

Make sure that the motorcycle is steady on its stand. ◀

- Make sure the ground is level and firm and park the motorcycle.
- Switch off ignition.

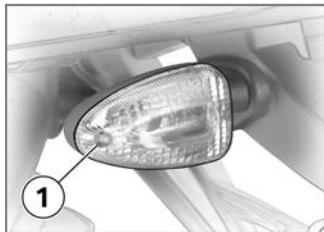

- Remove the screw **1**.



- Pull the lamp housing on the screw connection side out of the turn indicator housing.

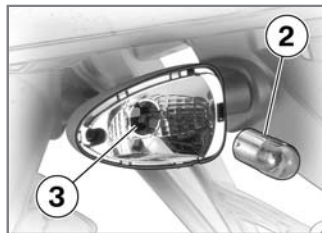

- Press bulb **2** into fitting **3** and remove it by turning it counterclockwise.
- Install turn indicator bulb in reverse order.
- Use a clean, dry cloth to hold new bulb.

Jump starting

 The wires leading to the onboard socket do not have a load-capacity rating adequate for jump-starting the engine. Excessively high current can lead to a cable

fire or damage to the motorcycle electronics.

Do not use the onboard socket to jump-start the motorcycle. ◀



Touching live parts of the ignition system with the engine running can cause electric shock.

Do not touch parts of the ignition system when the engine is running. ◀



A short-circuit can result if the crocodile clips of the jump leads are accidentally brought into contact with the motorcycle.

Use only jump leads fitted with fully insulated crocodile clips at both ends. ◀



Jump-starting with a donor-battery voltage higher than 12 V can damage the motorcycle electronics. The battery of the donor ve-

hicle must have a voltage of 12 V. ◀



If it is not standing firmly, the motorcycle could topple in the course of the operations described below. Make sure that the motorcycle is steady on its stand. ◀

- Make sure the ground is level and firm and park the motorcycle.
 - When jump-starting the engine, do not disconnect the battery from the onboard electrical system.
 - Remove screws.
 - Take out the battery compartment lid in a forward and upward direction.
 - Run the engine of the donor vehicle during jump-starting.
 - Begin by connecting one end of red jumper lead to positive terminal of discharged battery and
- the other end to positive terminal of donor battery.
- Then connect one end of black jumper lead to negative terminal of donor battery, and other end to negative terminal of discharged battery.
 - Start engine of motorcycle with discharged battery in usual way; if engine refuses to start, wait a few minutes before repeating attempt to protect starter and donor battery.
 - Allow both engines to idle for a few minutes before disconnecting jumper leads.
 - Disconnect the jump lead from the negative terminals first, then disconnect the second lead from the positive terminals.
 - Mount battery compartment cover and install screws **1**.

 To start the engine, do not use start sprays or similar items. ◀

Battery

Maintenance instructions

Correct upkeep, recharging and storage will prolong the life of the battery and are essential if warranty claims are to be considered.

Compliance with the points below is important in order to maximize battery life:

- Keep the surface of the battery clean and dry
- Do not open the battery
- Do not top up with water
- Be sure to read and comply with the instructions for charging the battery on the following pages
- Do not turn the battery upside down

 If the battery is not disconnected, the onboard electronics (clock etc.) will drain the battery. This can cause the battery to run flat. If this happens, warranty claims will not be accepted. During periods when the motorcycle is not being used, of more than four weeks, disconnect the battery from the motorcycle or connect a trickle charger to the battery. ◀

 BMW Motorrad has developed a trickle-charger specially designed for compatibility with the electronics of your motorcycle. Using this charger, you can keep the battery charged during long periods when the motorcycle is not being used without having to disconnect the battery from the motorcycle's onboard systems. You can

obtain additional information from your authorized BMW motorcycle retailer. ◀

Charging connected battery

 Charging the connected battery directly at the battery terminals can damage the motorcycle electronics. To charge the battery via the battery terminals, disconnect the battery first. ◀

 If you switch on the ignition and the multifunction display and indicator lights fail to light up, the battery is completely flat. Attempting to charge a completely flat battery via the onboard socket can cause damage to the motorcycle's electronics. Always charge a completely drained battery directly at the

terminals of the disconnected battery. ◀

 Charging the battery via the onboard socket is only possible with suitable chargers. Unsuitable chargers can result in damage to the motorcycle electronics. Use BMW chargers with the part numbers 71 60 7 688 864 (220 V) or 71 60 7 688 865 (110 V). If in doubt, charge the disconnected battery directly at the terminals. ◀

- Charge disconnected battery via onboard socket.

 The motorcycle's onboard electronics know when the battery is fully charged. The onboard socket is switched off when this happens. ◀

- Comply with operating instructions of charger.

 If you are unable to charge the battery via the onboard socket, you may be using a charger that is not compatible with your motorcycle's electronics. In this case, please charge the battery directly at the terminals of the disconnected battery. ◀

Charging disconnected battery

- Charge battery using a suitable charger.
- Comply with operating instructions of charger.
- Once battery is fully charged, disconnect charger terminal clips from battery terminals.

 In the case of longer periods when the motorcycle is not being used, the battery must be recharged regularly. See the instruc-

tions for caring for your battery. Always fully recharge the battery before returning it to use. ◀

Removing battery

 If it is not standing firmly, the motorcycle could topple in the course of the operations described below. Make sure that the motorcycle is steady on its stand. ◀

- Make sure the ground is level and firm and park the motorcycle.

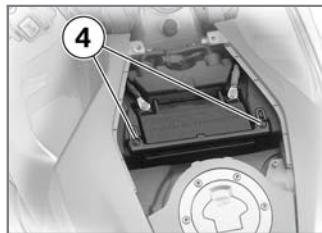
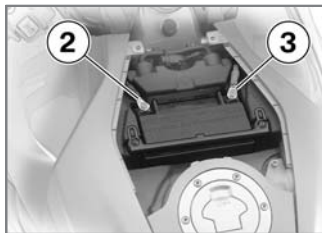
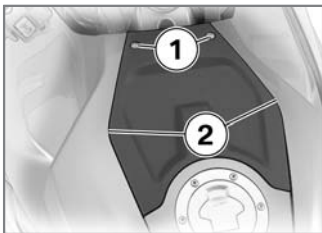

- Remove screws **1**.
- Take out the battery compartment lid in a forward and upward direction, while watching detents **2**.

! An incorrect disconnection sequence increase the risk of short-circuiting. Always observe the proper sequence. ◀

- Remove negative cable **2** first.
- Then remove the positive battery cable **3**.

- Unscrew screws **4** and pull retaining bracket toward rear.
- Lift battery upwards; if it is difficult to move, moving it back and forth will help.

Installing battery

! If it is not standing firmly, the motorcycle could topple in the course of the operations described below. Make sure that the motorcycle is steady on its stand. ◀

- Make sure the ground is level and firm and park the motorcycle.
- Switch off ignition.
- Place the battery in the battery compartment, positive terminal on the right in the direction of travel.

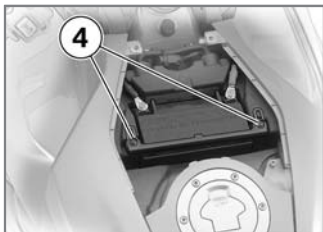

- Push retaining strap over battery and install screws **4**.

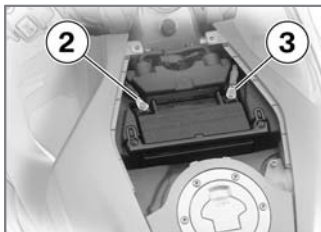

! An incorrect connection sequence increases the risk of short-circuiting. Always observe the proper sequence. Never install the battery without the protective cap. ◀

- First install the positive battery cable **3**.
- Then install the negative battery cable **2**.
- Mount battery compartment cover.

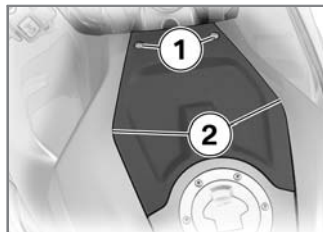

- Install battery compartment cover while watching detents **2**.
- Install screws **1**.
- Switch on ignition.
- Fully open the throttle once or twice.
- » The engine management system records the throttle-valve position.
- Setting clock (➡ 44)

Care

Care products	124
Washing your motorcycle	124
Cleaning sensitive motorcycle parts	125
Paint care	126
Protective wax coating	126
Storing motorcycle	126
Returning motorcycle to use	126

Care products

We recommend that you use the cleaning and care products you can obtain from your authorized BMW motorcycle retailer. The materials in BMW Care Products have been tested in laboratories and in practice; they provide optimized care and protection for the materials used in your motorcycle.

 The use of unsuitable cleaning and care products can damage motorcycle components.

For cleaning, do not use any solvents such as nitro-thinners, cold cleaning agents, fuel or similar, and do not use cleaning agents that contain alcohol. ◀

Washing your motorcycle

We recommend that you use BMW insect remover to soften and wash off insects and resilient dirt on painted parts prior to washing the motorcycle.

To prevent stains, do not wash the motorcycle immediately after it has been exposed to strong sunlight and do not wash it in the sun. Make sure that the motorcycle is washed frequently, especially during the winter months.

To remove road salt, clean the motorcycle with cold water immediately after every trip.

 After the motorcycle has been washed, ridden through water or ridden in the rain, the brake disks and

pads might be wet and the brakes might not take effect immediately.

Brake early until the brakes are dry or braked until dry. ◀

 Warm water intensifies the effect of salt.

Only use cold water to remove road salt. ◀

 The high pressure of steam cleaners can damage seals, the hydraulic brake system, the electrical system and the seat. Do not use a steam jet or high-pressure cleaning equipment. ◀

Cleaning sensitive motorcycle parts

Plastics

Clean plastic parts with water and BMW plastic care emulsion. This includes in particular:

- Windshields
- Headlight lens made of plastic
- Covering glass of instrument cluster
- Black, unpainted parts

 If plastic parts are cleaned using unsuitable cleaning agents, the surfaces can be damaged.

Do not use cleaning agents that contain alcohol, solvents or abrasives to clean plastic parts.

'Fly sponges' or sponges with hard surfaces can also lead to scratches. ◀

 Soften stubborn dirt and dead insects by covering the affected areas with a wet cloth. ◀

Windshield

Clean off dirt and insects with a soft sponge and plenty of water.

 Fuel and chemical solvents attack the windshield material; the windshield becomes cloudy or dull.

Do not use cleaning agents. ◀

Chrome

Especially in the case of road salt, carefully clean chrome parts with a great deal of water and BMW auto shampoo. Use chrome polish for additional treatment.

Radiator

Clean the radiator regularly to prevent overheating of the engine due to inadequate cooling.

For example, use a garden hose with low water pressure.

 Cooling fins can be bent easily.

When cleaning the radiator, ensure that the fins are not bent. ◀

Rubber

Treat rubber components with water or BMW rubber protection coating agent.

 Using silicone sprays for the care of rubber seals can cause damage.

Do not use silicon sprays or other care products that contain silicon. ◀

Paint care

Washing the motorcycle regularly will help counteract the long-term effects of substances that damage the paint, especially if your motorcycle is ridden in areas with high air pollution or natural sources of dirt, e.g. tree resin or pollen.

However, remove particularly aggressive materials immediately; otherwise changes in the paint or discoloration can occur. These include spilled fuel, oil, grease, brake fluid as well as bird droppings. BMW vehicle polish or BMW paint cleaner are recommended here.

Contamination on the paint finish is particularly easy to see after the motorcycle has been washed. Remove this type of soiling with cleaning naphtha or spirit on a clean

cloth or cotton ball. We recommend removing tar spots with BMW tar remover. Then add a protective wax coating to the paint at these locations.

Protective wax coating

For the protective wax coating of paint, we recommend using only BMW auto wax or agents that contain carnauba or synthetic waxes.

The best way to see whether the paint has to be protected is that water no longer forms pearls.

Storing motorcycle

- Clean motorcycle.
- Remove battery.
- Spray brake and clutch lever, and main and side

stand pivots with a suitable lubricant.

- Coat bare metal and chrome-plated parts with an acid-free grease (e.g. Vaseline).
- Park motorcycle in a dry room so that both wheels are unloaded.

 Before storing the vehicle, have the engine oil and the oil filter element changed by a certified workshop, preferably an authorized BMW motorcycle retailer. Combine work for storing/returning to use with maintenance service or an inspection. ◀

Returning motorcycle to use

- Remove protective wax coating.
- Clean motorcycle.

- Install a charged battery.
- Before starting: Observe checklist.

Technical data

Troubleshooting chart	130
Threaded fasteners	131
Engine	132
Riding specifications	134
Clutch	134
Transmission	134
Rear-wheel drive	135
Running gear	135
Brakes	136
Wheels and tires	136
Electrical system	137
Frame	139
Dimensions	139
Weights	140

Troubleshooting chart

Engine does not start at all or is very difficult to start

Possible cause

Remedy

Emergency ON/OFF switch activated.

Emergency ON/OFF switch in operating position.

Side stand extended and gear engaged.

Retract side stand (➡ 62).

Gear engaged and clutch not operated

Place transmission in neutral or disengage clutch(➡ 62).

Clutch disengaged with ignition switched off.

Switch on ignition first, then disengage clutch.

No fuel in tank.

Refueling (➡ 76)

Battery not adequately charged.

Charging connected battery (➡ 119)

Threaded fasteners

Activity	Type of threaded fastener	Tightening torques
Front wheel		
Front brake caliper mounted on wheel carrier	M8 x 32 - 10.9	22 lb/ft (Left)
	M8 x 32 - 10.9	22 lb/ft (Right)
Clamping screw on quick-release axle in wheel carrier	M8 x 30	14 lb/ft
Quick-release axle in threaded bush	M24 x 1.5	37 lb/ft
Rear wheel		
Muffler on right passenger footrest	M8 x 30	21 lb/ft
Muffler on manifold	M8 - 10.9 self-locking, Optimoly TA	26 lb/ft
Rear wheel on wheel flange	M10 x 43 x 1.25	44 lb/ft
	M10 x 40 x 1.25	44 lb/ft

Engine

Type

Engine design	Transverse-mounted four-cylinder, four-stroke inline engine, angled 55° toward front. With four valves per cylinder, actuated by two overhead camshafts and trailing valve levers; liquid cooled, electronic fuel injection, integrated six-speed cassette transmission, dry-sump lubrication
---------------	---

Technical data

Effective displacement	1157 cc
Cylinder bore	3.1 in
Piston stroke	2.3 in
Compression ratio	13:1
Rated output	167 hp, - at engine speed: 10250 min ⁻¹
with OE Power reduction:	101 hp, - at engine speed: 7000 min ⁻¹
with OE Power reduction:	107 hp, - at engine speed: 8750 min ⁻¹
Maximum torque	96 lb/ft, - at engine speed: 8250 min ⁻¹
Permissible maximum engine speed	11000 min ⁻¹
Idle speed	1150 ^{±50} min ⁻¹

Fuel

Recommended fuel type	Premium grade unleaded fuel 98 ROZ
-----------------------	---------------------------------------

Fuel types can be used with poorer performance and consumption	Super unleaded 95 ROZ
--	--------------------------

Fuel tank capacity	5 gal, Usable 1.1 gal, Of that reserve
--------------------	---

Engine oil

Total engine oil capacity	3.7 quarts, With filter change 0.5 quarts, Difference between Min and Max
---------------------------	--

Lubricant	Castrol GPS 10W-40 (SAE 10W40; API SG; JASO MA)
-----------	--

Oil grades	Mineral engine oils of the API classification SF to SH. BMW Motorrad does not recommend using oil additives, as these can worsen clutch operation.
------------	--

Permissible viscosity classes

SAE 5 W->30	-4...68 °F, Winter operation
-------------	------------------------------

SAE 10 W-40	14...86 °F, At low temperatures
-------------	---------------------------------

Riding specifications

Top speed	>124 mph
Acceleration 0-62 mph (0-100 km/h)	2.8 s

Clutch

Clutch design	Multi-disk oil-bath clutch
---------------	----------------------------

Transmission

Transmission design	Claw-shifted 6-speed cassette transmission integrated in engine housing
---------------------	---

Gear ratios

Overall gear ratio in 1st gear	2.521
Overall gear ratio in 2nd gear	1.842
Overall gear ratio in 3rd gear	1.455
Overall gear ratio in 4th gear	1.287
Overall gear ratio in 5th gear	1.143
Overall gear ratio in 6th gear	1.015

Rear-wheel drive

Rear-wheel drive design	Shaft drive with bevel gears
Gear ratio of rear-wheel drive	2.82:1

Running gear

Front suspension design	Double leading link
Total suspension travel of front suspension	4.5 in, Static 4.9 in, Dynamic
Rear suspension design	Single-tube gas pressure shock-absorber
Total suspension travel of rear-wheel suspension	5.3 in, On wheel

Brakes

Front brake design	Hydraulic two-disk brake with 4-piston fixed calipers and floating brake disks
Front brake-pad material	Sintered metal
Rear brake design	Hydraulic disk brake with 2-piston floating caliper and fixed brake disk
Rear brake-pad material	Organic

Wheels and tires

Front wheel design	Cast aluminum, MT H2
Front-wheel rim size	3.50" x 17"
Front-wheel tire designation	120/70 ZR 17
Rear wheel design	Cast aluminum, MT H2
Rear-wheel rim size	6.00" x 17"
Rear-wheel tire designation	190/50 ZR17

Tire pressures

Front-wheel tire pressure	36.3 psi, In cold state
Rear-wheel tire pressure	42.1 psi, In cold state

Electrical system

Rated load of onboard socket	5 A
Fuses	All circuits are electronically protected, so plug-in fuses are no longer necessary. If an electronic fuse trips and de-energizes a circuit, the circuit is active as soon as the ignition is switched on after the fault has been rectified.
Type	
Battery design	AGM (Absorptive Glass Matt) battery
Technical data	
Battery nominal voltage	12 V
Battery nominal capacity	14 Ah
Battery low-temperature test current	100 A
Technical data	
Spark plug manufacturer and designation	Bosch YR5DDE
Spark-plug electrode gap New	0.03 in
Spark-plug electrode gap Wear limit	No wear limit, spark plug is replaced after maintenance interval

Bulbs

High-beam headlight bulb - standard designation	Halogen bulb H7
High-beam headlight bulb - voltage	12 V
High-beam headlight bulb - wattage	55 W
Low-beam headlight bulb- standard designation	Halogen bulb H7
Low-beam headlight bulb - voltage	12 V
Low-beam headlight bulb - wattage	55 W
Side-light bulb standard designation	W5W
Side-light bulb voltage	12 V
Side-light bulb wattage	5 W
Tail light/brake light bulb standard designation	P21W
Tail light/brake light bulb voltage	12 V
Tail light/brake light bulb wattage	21 W
Front turn indicator bulb standard designation	W16W
Front turn indicator bulb voltage	12 V
Front turn indicator bulb wattage	10 W
License-plate light bulb standard designation	W5W
License-plate light bulb voltage	12 V

License-plate light bulb wattage	5 W
----------------------------------	-----

Frame

Main frame design	Composite with IHU/extruded section and diecasting
-------------------	--

Location of type plate	On rear cross frame tube
------------------------	--------------------------

Location of vehicle identification number (VIN)	At front right on frame side-section
---	--------------------------------------

Dimensions

Overall motorcycle length	86.7 in
---------------------------	---------

Maximum width	35.6 in, Across mirrors
---------------	-------------------------

Maximum height	47.7 in, DIN unladen weight
----------------	-----------------------------

Seat height for driver	32.3 in, Without driver
------------------------	-------------------------

with OE Low driver's seat:	31.1 in, Without driver
----------------------------	-------------------------

Wheelbase in normal-load position	61.9 in, Full tank of gas, with rider: 187 lbs
-----------------------------------	--

Ground clearance	5.7 in, In normal-load position, full tank of gas, with rider: 187 lbs
------------------	--

Weights

Unladen weight	547 lbs, DIN unladen weight, ready for road, 85 % full tank of gas, without OE
Permissible gross weight	992 lbs
Maximum payload	445 lbs

Service

BMW Motorrad service	142
BMW Motorrad service quality	142
BMW Motorcycle Service Card - breakdown service on the road	143
BMW Motorrad service network	143
Maintenance work	143
Maintenance schedules	144
Confirmation of maintenance work	145
Confirmation of service	150

BMW Motorrad service

Advanced technology requires specially adapted methods of maintenance and repair.

 If this maintenance and repair work is performed inexpertly, there is a danger of damage and associated safety risks.

BMW recommends only having work carried out on your motorcycle by an authorized BMW motorcycle retailer or a workshop which works with personnel trained in accordance with BMW specifications. ◀

You can contact your BMW motorcycle retailer for information on the contents of BMW Service, inspections and the Annual Inspection.

Have all maintenance and repair work carried out confirmed in the "Service" chapter in this manual.

Your authorized BMW motorcycle retailer is supplied with all the latest technical information and therefore possesses the necessary technical know-how. BMW Motorrad therefore recommends that you consult your authorized BMW motorcycle retailer on all questions concerning your motorcycle.

BMW Motorrad service quality

BMW Motorrad stands not only for good handling and a high degree of reliability, but also for an excellent quality of service.

To ensure that your BMW is always in optimum condition, we recommend that you

have the maintenance work required for your motorcycle carried out, preferably by your authorized BMW motorcycle retailer. For generous treatment of claims submitted after the warranty period has expired, evidence of regular maintenance is essential. Certain signs of wear, moreover, may otherwise not be noticed until it is too late to correct them at moderate cost. The workshop personnel at BMW motorcycle retailers are familiar with your motorcycle and can take action before minor problems can turn into major trouble. By having the necessary repairs done properly and in good time, you save time and money in the long run.

BMW Motorcycle Service Card - breakdown service on the road

With all new BMW motorcycles, the BMW Motorrad Service Card protects you in the event of a breakdown with an extensive range of services such as breakdown assistance, motorcycle transportation etc. (differing regulations are possible in individual countries). In the case of a breakdown, you contact the Mobile Service of BMW Motorrad. Here you will find our specialists ready to help with both advice and action. Important country-specific contact addresses and the relevant after-sales service organization phone numbers as well as information on Mobile Service and the dealership network can be found in

the "Service Kontakt / Service Contact" brochures.

BMW Motorrad service network

With our worldwide service network we support you and your motorcycle in over 100 countries around the globe. In Germany alone, you have the best possible access to approximately 200 authorized BMW motorcycle retailers. All information on the international dealership network is contained in the "Service Contact Europe" brochure and "Service Contact Africa, America, Asia, Australia and Oceania".

Maintenance work Intervals

Some maintenance tasks must be performed after a certain time, others depend on the distance covered by the motorcycle.

BMW Running-in Check

The BMW running-in check has to be performed when the motorcycle has covered between 300 miles (500 km) and 750 miles (1,200 km).

BMW Annual Inspection

Some maintenance work must be carried out at least once a year. Other tasks depend on the distance the motorcycle has covered.

BMW Service

After the first 6,000 miles (10,000 km) and every additional 12,000 miles (20,000 km) (24,000 miles, 36,000 miles, 48,000 miles etc. (40 000 km, 60 000 km, 80 000 km etc.)) if this distance is covered within a year.

BMW Inspection

After the first 12,000 miles (20,000 km) and every additional 12,000 miles (20,000 km) (24,000 miles, 36,000 miles, 48,000 miles etc. (40 000 km, 60 000 km, 80 000 km etc.)) if this distance is covered within a year.

Maintenance schedules

The maintenance schedule for your motorcycle depends on the equipment installed, and on the motorcycle's age and the distance it has covered. Your authorized BMW motorcycle retailer will be happy to supply a copy of the current maintenance schedule for your motorcycle on request.

 Every authorized BMW motorcycle retailer has a fixed scale of charges based on labor times and carefully calculated hourly rates. Fuel, lubricants and similar substances, filters, gaskets etc. are charged separately. ◀

Confirmation of maintenance work

BMW Pre-delivery Check

Carried out properly in accordance with workshop specifications.

Date, stamp, signature

BMW Running-in Check

Carried out properly in accordance with workshop specifications.

at miles: _____

- Brake fluid changed
- Without BMW Integral ABS
 - With BMW Integral ABS
 - Wheel circuit
 - Control circuit

Date, stamp, signature

BMW Service

- BMW Annual Inspection
- BMW Service
- BMW Inspection

Carried out properly in accordance with workshop specifications.

at miles: _____

Brake fluid changed

- Without BMW Integral ABS
- With BMW Integral ABS
 - Wheel circuit
 - Control circuit

Date, stamp, signature

BMW Service

- BMW Annual Inspection
- BMW Service
- BMW Inspection

Carried out properly in accordance with workshop specifications.

at miles: _____

Brake fluid changed

- Without BMW Integral ABS
- With BMW Integral ABS
 - Wheel circuit
 - Control circuit

Date, stamp, signature

BMW Service

- BMW Annual Inspection
- BMW Service
- BMW Inspection

Carried out properly in accordance with workshop specifications.

at miles: _____

Brake fluid changed

- Without BMW Integral ABS
- With BMW Integral ABS
 - Wheel circuit
 - Control circuit

Date, stamp, signature

BMW Service

- BMW Annual Inspection
- BMW Service
- BMW Inspection

Carried out properly in accordance with workshop specifications.

at miles: _____

Brake fluid changed

- Without BMW Integral ABS
- With BMW Integral ABS
 - Wheel circuit
 - Control circuit

Date, stamp, signature

BMW Service

- BMW Annual Inspection
- BMW Service
- BMW Inspection

Carried out properly in accordance with workshop specifications.

at miles: _____

Brake fluid changed

- Without BMW Integral ABS
- With BMW Integral ABS
 - Wheel circuit
 - Control circuit

Date, stamp, signature

BMW Service

- BMW Annual Inspection
- BMW Service
- BMW Inspection

Carried out properly in accordance with workshop specifications.

at miles: _____

Brake fluid changed

- Without BMW Integral ABS
- With BMW Integral ABS
 - Wheel circuit
 - Control circuit

Date, stamp, signature

BMW Service

- BMW Annual Inspection
- BMW Service
- BMW Inspection

Carried out properly in accordance with workshop specifications.

at miles: _____

Brake fluid changed

- Without BMW Integral ABS
- With BMW Integral ABS
 - Wheel circuit
 - Control circuit

Date, stamp, signature

BMW Service

- BMW Annual Inspection
- BMW Service
- BMW Inspection

Carried out properly in accordance with workshop specifications.

at miles: _____

Brake fluid changed

- Without BMW Integral ABS
- With BMW Integral ABS
 - Wheel circuit
 - Control circuit

Date, stamp, signature

BMW Service

- BMW Annual Inspection
- BMW Service
- BMW Inspection

Carried out properly in accordance with workshop specifications.

at miles: _____

Brake fluid changed

- Without BMW Integral ABS
- With BMW Integral ABS
 - Wheel circuit
 - Control circuit

Date, stamp, signature

BMW Service

- BMW Annual Inspection
- BMW Service
- BMW Inspection

Carried out properly in accordance with workshop specifications.

at miles: _____

Brake fluid changed

- Without BMW Integral ABS
- With BMW Integral ABS
 - Wheel circuit
 - Control circuit

Date, stamp, signature

BMW Service

- BMW Annual Inspection
- BMW Service
- BMW Inspection

Carried out properly in accordance with workshop specifications.

at miles: _____

Brake fluid changed

- Without BMW Integral ABS
- With BMW Integral ABS
 - Wheel circuit
 - Control circuit

Date, stamp, signature

BMW Service

- BMW Annual Inspection
- BMW Service
- BMW Inspection

Carried out properly in accordance with workshop specifications.

at miles: _____

Brake fluid changed

- Without BMW Integral ABS
- With BMW Integral ABS
 - Wheel circuit
 - Control circuit

Date, stamp, signature

Work carried out	at miles:	Date

- A**
Abbreviations and symbols, 6
Anti-theft alarm, 17
- B**
Battery
 Battery charging-current warning indicator, 26
 Charging connected battery, 119
 Charging disconnected battery, 120
 Installing, 121
 Removing, 120
Brake fluid
 Checking front level, 97
 Checking rear level, 98
Brake pads
 Checking front, 95
 Checking rear, 96
Brakes
 Technical data, 136
- C**
Case
 Adapting, 89
 Adjusting, 86
 Closing, 86
 Mounting, 88
 Opening, 86
 Removing, 87
Clock, 20
 Adjusting, 17
 Setting, 44
Clutch
 Fluid reservoir, 11, 13
 Technical data, 134
Commissioning, 126
Confirmation of maintenance work, 145
Coolant
 Coolant-temperature warning indicator, 24
 Temperature display, 21
- E**
Electrical system
 Technical data, 137
Emergency ON/OFF switch, 16, 45
Engine
 Engine-electronics warning indicator, 25
 Technical data, 132
 Temperature display, 20
Engine oil
 Checking level, 92
 Engine oil-pressure warning indicator, 25
 Technical data, 133
 Topping up, 94
ESA, 55
 Adjusting damping, 56
 Adjusting spring preload, 56
 Calling up settings, 56
EWS
 Warning indicator, 24
- F**
Flat tire kit, 89

Frame
 Technical data, 139
Front wheel stand
 Mounting, 109
Fuel
 Quantity indicator, 20
 Refueling, 76
 Reserve-quantity warning indicator, 24
 Technical data, 133
Fuses, 137

G
Gear indicator, 20

H
Handlebar fittings
 General view, left , 15
 General view, right, 16
Hazard warning flashers, 15,
 16
 Switching off, 39
 Switching on, 38

Headlight
 Adjusting headlight range, 48
 High-beam headlight, 18
 Low-beam headlight, 18
 Side lights, 18
Headlight flasher, 15
Heated hand grips, 16, 45
High-beam headlight, 15
Horn, 15

I
Ignition
 Switching off, 36
 Switching on, 36
Immobilizer
 Warning indicator, 24
Indicator lights, 17
Instrument cluster
 Lighting sensor, 17
 Overview, 17

J
Jump starting, 117

L
Lamps
 Bulb-defect warning indicator, 26, 27
 General instructions, 111
 Replacing brake light bulbs, 115
 Replacing front turn indicator bulb, 116
 Replacing high-beam bulb, 113
 Replacing low-beam bulb, 112
 Replacing rear light bulbs, 115
 Replacing rear turn indicator bulb, 116
 Replacing side-light bulb, 114
 Technical data, 138

Lights

- Switching off side lights, 48
- Switching on high-beam headlight, 47
- Switching on low-beam headlight, 47
- Switching on side lights, 47, 48

M**Motorcycle**

- General view of left side, 11
 - General view of right side, 13
 - returning to use, 126
 - Storing, 126
- Multifunction display, 17, 20

O**Onboard computer**

- Ambient temperature, 43
- Average consumption, 43
- Average speed, 42
- Button, 15

Resetting average consumption, 43

Resetting average speed, 42

Residual range, 42

Selecting readings, 41

Tripmaster operation, 41

Onboard socket, 11, 13

Overview of warning indicators, 22, 29

P

Pre-ride check, 63

R

Rear shock absorber system
Adjusting, 11, 13, 54

Rear suspension preload
Adjusting, 11, 13, 54

Rear-wheel drive
Technical data, 135

Rear-wheel stand
Mounting, 110

Refueling, 76

Reserve

Warning indicator, 24

Residual range, 40, 42

Running gear

Technical data, 135

S**Seat**

- Installing, 51
- Lock, 11, 13
- Removing, 50

Service, 142

Side stand

During starting, 62

Speedometer, 17

Starter, 16

Steering lock, 37

Storing, 126

T

Tachometer, 17

Technical data

- Brakes, 136
- Bulbs, 138
- Clutch, 134
- Electrical system, 137

- Engine, 132
 - Engine oil, 133
 - Frame, 139
 - Fuel, 133
 - Rear-wheel drive, 135
 - Running gear, 135
 - Transmission, 134
 - Wheels and tires, 136
- Tires
- Checking air pressure, 57
 - Checking tread depth, 100
 - Technical data, 136
- Toolkit
- Overview of basic set, 92
 - Overview of supplemental set, 92
- Torques, 129
- Transmission
- During starting, 62
 - Technical data, 134
- Tripmaster, 20
- Operation, 39
 - Resetting tripmeter, 40
 - Residual range, 40
 - Selecting readings, 39
- Troubleshooting chart, 130
- Turn indicators
- Left, 15, 49
 - Right, 16, 49
 - Switching off, 16, 50
- W**
- Warning indicators, 20
- Display, 21
- Warning lights, 17
- Wheels
- Installing front wheel, 103
 - Installing rear wheel, 106
 - Removing front wheel, 101
 - Removing rear wheel, 105
 - Technical data, 136

Details described or illustrated in this booklet may differ from the motorcycle's actual specification as purchased, the accessories fitted or the national-market specification. No claims will be entertained as a result of such discrepancies.

Dimensions, weights, fuel consumption and performance data are quoted to the customary tolerances. The right to modify designs, equipment and accessories is reserved.

Errors and omissions excepted.

© 2005 BMW Motorrad

Not to be reproduced either wholly or in part without written permission from BMW Motorrad, After Sales.

Printed in Germany.

The most important data for a filling station stop can be found in the following chart.

Fuel	
Recommended fuel type	Premium grade unleaded fuel 98 ROZ
Minimum octane number	95 ROZ
Fuel tank capacity	5 gal, Usable 1.1 gal, Of that reserve
Tire pressures	
Front-wheel tire pressure	36.3 psi, In cold state
Rear-wheel tire pressure	42.1 psi, In cold state



BMW Motorrad

Order No.:
01 47 7 698 347
08.2005
3rd Edition



The Ultimate Riding
Machine

Please attach this sticker to the inside back cover page of your Rider's Manual

Reporting Safety Defects

If you believe that your vehicle has a defect which could cause a crash or could cause injury or death, you should immediately inform the National Highway Traffic Safety Administration (NHTSA) in addition to notifying BMW of North America, LLC.

If NHTSA receives similar complaints, it may open an investigation, and if it finds that a safety defect exists in a group of vehicles, it may order a recall and remedy campaign. However, NHTSA cannot become involved in

individual problems between you, your dealer, or BMW of North America, LLC.

To contact NHTSA, you may call the Vehicle Safety Hotline toll-free at 1-888-327-4236

(TTY: 1-800-424-9153); go to <http://www.safercar.gov>, or write to: Administrator, NHTSA, 400 Seventh Street, SW., Washington, DC 20590. You can also obtain other information about motor vehicle safety from <http://www.safercar.gov>.

BMW Motorrad

Order No: 01 47 7 706 697

08.2006

Information on BMW Motorrad Integral ABS

How does ABS work?

The maximum braking force which can be transferred to the road surface is partially dependent on the coefficient of friction of the road surface. Gravel, ice, snow and wet road surfaces offer a considerably poorer coefficient of friction than a dry, clean layer of asphalt. The lower the coefficient of friction of the road surface is, the longer the braking distance will be. If the maximum transferrable braking force is exceeded when the driver increases the brake pressure applied, the wheels begin to lock and the driving stability is lost,

resulting in a danger of falling. Before this situation occurs, the ABS intervenes and adjusts the brake pressure to the maximum transferrable braking force. As a result, the wheels continue to turn and the driving stability is maintained regardless of the road surface condition.

What happens on uneven road surfaces?

Wavy ground or uneven road surfaces can briefly result in a loss of contact between the tire and the road surface, and the transferrable braking force decreases to zero. If the brakes are applied in this situation, the ABS must reduce the brake pressure to

ensure driving stability when contact with the road surface is restored. At this point in time the BMW Motorrad Integral ABS must assume extremely low coefficients of friction (gravel, ice or snow) so that the wheels turn in every imaginable case and the driving stability is ensured. After the actual conditions are detected, the system adjusts the brake pressure to the optimum value.

What must be observed during driving safety training?

Compared to normal braking, braking during which the ABS must intervene in a regulating manner requires a consider-

ably increased amount of current, which places a heavy load on the battery.

During normal driving the battery is constantly charged, and therefore has a sufficient capacity.

During driving breaks of several weeks, a trickle-charger available from an authorized BMW Motorrad retailer should be connected or the battery should be disconnected and recharged before the next time the motorcycle is driven.

During driving-safety training courses an unusually high number of ABS-controlled braking actions take place within a short time. Between those actions there are waiting and evaluation phases during which the motorcycle is not

driven. The battery is heavily loaded by the ABS control actions, however at the same time it is not recharged, as virtually no driving takes place. In isolated cases, braking actions of this kind in this artificially produced situation during which the brake lever is pulled with maximum force and extremely quickly, in combination with a decreasing electrical system voltage, push the ABS to technical limits at which the control function is no longer fulfilled. Field observations by BMW Motorrad show that no comparable situations occur in road traffic or during circuit training.

During safety training the following instructions must be followed:

- Observe the warning and control lights before each braking exercise
- Drive a longer distance after a maximum of five braking exercises to charge the battery
- Switch off consumers like seat and hand grip heaters, radio, navigation system and accessories connected to the sockets
- Switch off the ignition during breaks and conversations. If the engine is switched off with the emergency ON/OFF switch, the light and all electronic systems remain switched on and load the battery

How can the shortest braking distance be achieved?

During braking the dynamic load distribution between the front and rear wheel changes. The heavier braking is, the higher the load on the front wheel. The greater the wheel load, the more braking force can be transferred.

To achieve the shortest possible braking distance, the front brake must be operated quickly and with increasing force. This optimally utilizes the dynamic load increase on the front wheel. At the same time, the clutch should also be disengaged.

With the "forced braking" often practiced, during which the brake pressure is generated

as quickly as possible and with maximum force, the dynamic load distribution is unable to follow the increase in deceleration and the brake force cannot be completely transferred to the road surface. To prevent locking of the front wheel, the ABS must intervene and reduce the brake pressure, which increases the braking distance.

What happens when the ABS control function fails?

A fault in the BMW Motorrad Integral ABS is indicated by a corresponding warning in the instrument cluster.

If only the ABS control function fails, the integral system and the brake booster continue to operate. If these systems also

fail, the residual braking function is activated. In this case, the forces to be applied to the brake levers are considerably higher and the required lever travel increases.

The residual braking function is a mechanical function and is always available when the BMW Motorrad Integral ABS fails, regardless of the battery charging level. It meets all requirements of the worldwide legislation on the brake design of motor vehicles and enables the rider to brake the motorcycle.

When driving with the residual braking function, the following instructions must be followed:

- Adjust the brake levers to the maximum travel

- Always brake with the front and rear brakes
- In clear situations, carry out test braking to learn the response behavior of the brakes
- Observe the condition of the road surface and adapt the braking force applied accordingly
- As it is an emergency running function, you should drive to a specialized workshop, preferably an authorized BMW Motorrad retailer, as quickly as possible

How important is regular maintenance?



Any technical system is always only as good as its maintenance status. To ensure that the BMW Motorrad Integral ABS is in optimum condition with regard to maintenance, the specified inspection intervals must always be complied with. ◀

How is the BMW Motorrad Integral ABS designed?

The BMW Motorrad Integral ABS ensures the driving stability of the motorcycle on any surface within the physical limits of driving. The system is not optimized for special requirements resulting under extreme weather conditions on offroad terrain or on racing circuits.

BMW Motorrad

Order No.:
01 47 7 699 277
07.2005
1st edition US/RF



The Ultimate
Riding Machine