

## **Doors and locks**

---

<b>Keys</b> .....	<b>2-2</b>
<i>Master, submaster and valet key</i> .....	<b>2-2</b>
<i>Key number</i> .....	<b>2-2</b>
<b>Door locks</b> .....	<b>2-3</b>
<i>Power door locking switches</i> .....	<b>2-5</b>
<b>Keyless entry system (if equipped)</b> .....	<b>2-6</b>
<b>Security system (if equipped)</b> .....	<b>2-12</b>
<b>Child safety locks</b> .....	<b>2-19</b>
<b>Power windows</b> .....	<b>2-20</b>
<b>Rear gate</b> .....	<b>2-23</b>
<b>Moonroof (if equipped)</b> .....	<b>2-24</b>

---

## Keys

---

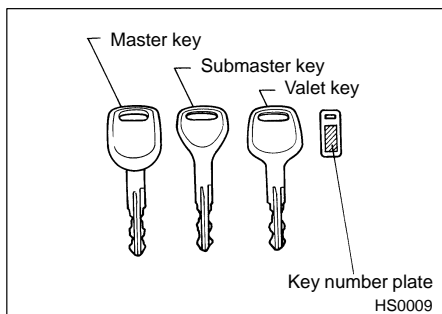

### ■ Master, submaster and valet key

Three types of keys are provided for your vehicle. Master key, submaster key and valet key.

The master key and submaster key fit all locks on your vehicle.

- Ignition switch
- Doors
- Rear gate
- Glove compartment

The valet key fits only the ignition switch and door locks. You can keep the glove compartment locked when you leave your vehicle and valet key at a parking facility.

### ■ Key number

The key number is stamped on the metal plate attached to the key set. Write down the key number and keep it in another safe place, not in the vehicle. This number is needed to make a replacement key if you lose your key or lock it inside the vehicle.

## Door locks

### ▼ Locking and unlocking from the outside

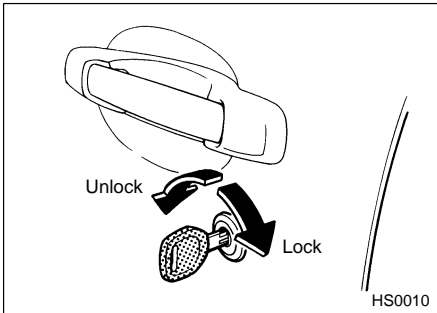

To lock the door from the outside with the key, turn the key toward the rear. To unlock the door, turn the key toward the front.

Pull the outside door handle to open an unlocked door.

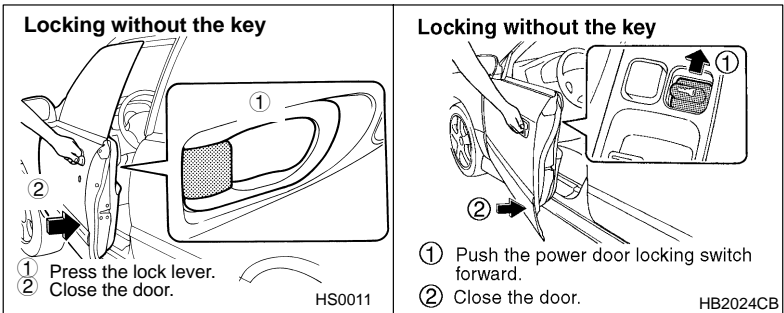

To lock the door from the outside without the key, press the end of the lock lever down on the door and then close the door.

To lock the door from the outside using the power door locking switch, push the switch forward ("LOCK" side) and then close the door. In this case, all closed doors and the rear gate are locked at the same time.

---

Always make sure that all doors and the rear gate are locked before leaving your vehicle.

## NOTE

**Make sure that you do not leave the key inside the vehicle before locking the doors from the outside without the key.**

### ▼ Locking and unlocking from the inside

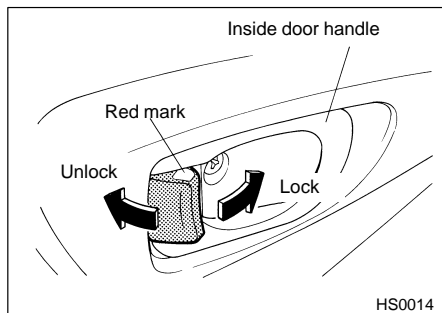

To lock the door from the inside, press the end of the lock lever down.  
To unlock the door from the inside, pull the front end of the lock lever.

The red mark on the lock lever appears when the door is unlocked.

Pull the inside door handle to open an unlocked door.

Always make sure that all doors and the rear gate are closed before starting to drive.

## ■ Power door locking switches

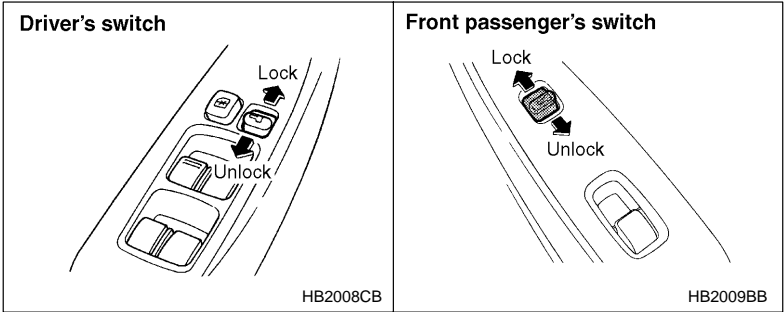

All doors and the rear gate can be locked and unlocked by the power door locking switches located at the driver's side and the front passenger's side doors.

To lock the doors, push the switch forward.

To unlock the doors, push the switch rearward.

When you close the doors after you set the door locks, the doors remain locked.

### NOTE

**Make sure that you do not leave the key inside the vehicle before locking the doors from the outside using power door locking switches.**

---

## Keyless entry system (if equipped)

---

### CAUTION

- Do not expose the transmitter to severe shocks, such as those experienced as a result of dropping or throwing.
- Do not take the transmitter apart except when replacing the battery.
- Do not get the transmitter wet. If it gets wet, wipe it dry with a cloth immediately.

**This device complies with Part 15 of the FCC Rules and with RSS-210 of Industry Canada. Operation is subject to the following two conditions: (1) This device may not cause harmful interference, and (2) this device must accept any interference received, including interference that may cause undesired operation.**

**Changes or modifications not expressly approved by the party responsible for compliance could void the user's authority to operate the equipment.**

Two transmitters are provided for your vehicle.

The keyless entry system has the following functions.

- Locking and unlocking the doors and rear gate without a key
- Sounding a panic alarm
- Arming and disarming the security system (if your vehicle is equipped with an optional security system). See the next section "Security system (if equipped)" for detailed information.

The operable distance of the keyless entry system is approximately 30 feet (10 meters). However, this distance will vary depending on environmental conditions. Range may be reduced near sources of RF interference such as power plants and radio/television broadcasting towers.

The keyless entry system does not operate when the key is inserted in the ignition switch.

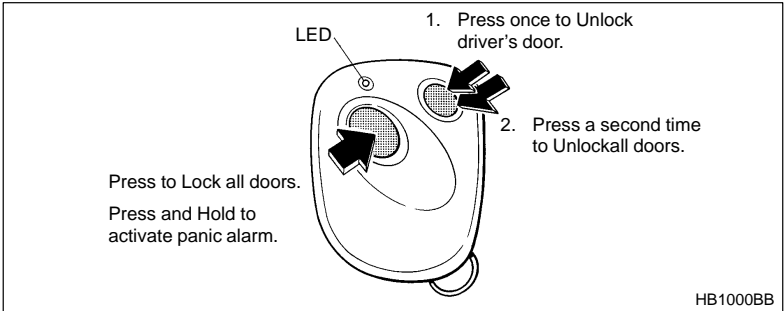

### ▼ Locking the doors

Briefly press the “LOCK/ARM” button (for less than two seconds) to lock all doors and rear gate. The horn will sound one time.

If any of the doors or the rear gate is not fully closed, the horn will sound three times to alert you that the doors (or the rear gate) are not properly closed. When you close the door, it will automatically lock.

### ▼ Unlocking the doors

Briefly press the “UNLOCK/DISARM” button (for less than two seconds) to unlock the driver's door. The horn will sound two times. To unlock all doors and rear gate, briefly press the “UNLOCK/DISARM” button a second time.

### ▼ Illuminated entry

The interior (dome) light will illuminate when the “UNLOCK/DISARM” button is pressed. The light will illuminate for approximately 30 seconds or until the key is inserted in the ignition switch or until the “LOCK/ARM” button is pressed. Once any of the doors or the rear gate is opened, this function will be canceled. The interior light must be set to **the middle position** in order for this function to operate.

### ▼ Sounding a panic alarm

To activate the alarm, keep the “LOCK/ARM” button pressed **for more than two seconds**.

To deactivate it, press the “LOCK/ARM” button or “UNLOCK/DISARM” button. Unless a button on the remote is pressed, the alarm will be deactivated after approximately 30 seconds.

– CONTINUED –

### ▼ Selecting audible signal operation

Using the horn, the system will give you an audible signal when the doors lock and unlock. If desired, you may turn the audible signal off. To turn the audible signal off, simultaneously depress "LOCK/ARM" and "UNLOCK/DISARM" buttons for more than two seconds. The horn will sound two times to inform you that the audible signal has been turned off.

To turn the audible signal on, simultaneously depress "LOCK/ARM" and "UNLOCK/DISARM" buttons for more than two seconds. The horn will sound one time to inform you that the audible signal has been turned on.

### ▼ Replacing the battery



#### **CAUTION**

**Do not let dust, oil or water get on or in the transmitter when replacing the battery.**

When the transmitter battery begins to get weak, transmitter range will begin to decrease and the LED will not illuminate. Replace the battery as soon as possible.

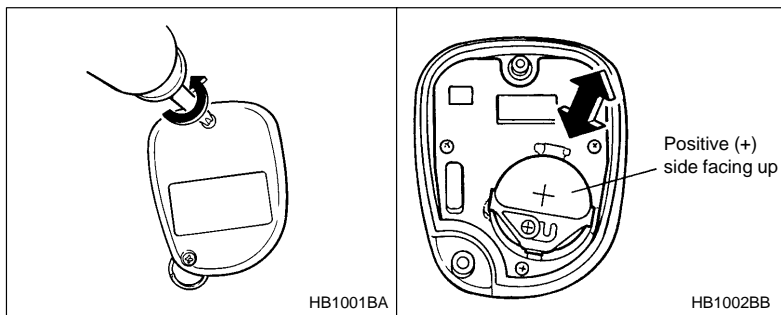

To replace the battery:

1. Remove the two screws on the back of the transmitter case by using a phillips screwdriver.
2. Separate the case.



3. Remove the old battery from the holder.
4. Replace with a new battery (Type CR2032 or equivalent) making sure to install the new battery with the positive (+) side facing up.
5. Install the back half of the transmitter case.
6. Reinstall the two screws on the back of the transmitter case.

**After the battery is replaced, the transmitter must be synchronized with the keyless entry system's control unit. Press either the "LOCK/ARM" or "UNLOCK/DISARM" button *six times* to synchronize the unit.**

### ▼ Replacing lost transmitters

If you lose a transmitter or want to purchase additional transmitters (up to four can be programmed), you should re-program all of your transmitters for security reasons. It is recommended that you have your dealer program all of your transmitters into your system.

### ▽ Programming the transmitters

The keyless entry system is equipped with a special code learning feature that allows you to program new transmitter codes into the system or to delete old ones. The system can learn up to four unique transmitter codes. The four transmitter codes may be the same or different.

### To enter the programming mode:

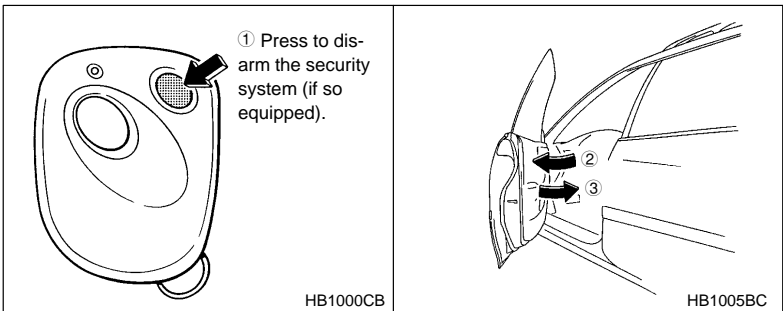

1. Disarm the security system. (if your vehicle is equipped with the optional security system.)

– CONTINUED –

2. Open the driver's door and sit in the driver's seat.
3. Close the driver's door.

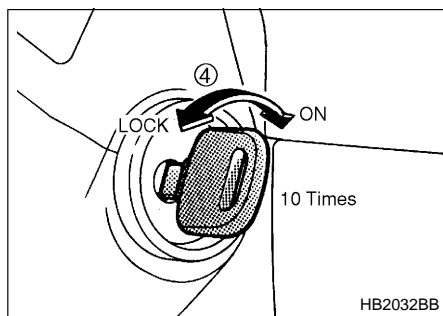

4. Place the ignition key into the ignition switch and cycle the switch from LOCK to ON ten times **within 15 seconds**. Be sure to stop at the LOCK position **and leave the key in the ignition**. The horn will sound once to indicate that you are in the transmitter programming mode.

## NOTE

**You must finish the next step (opening the driver's door) within 45 seconds of starting this procedures.**

**To program the transmitters:**

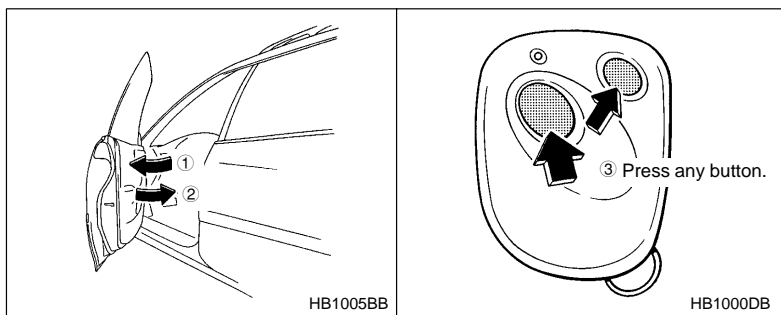

1. Open the driver's door.
2. Close the driver's door.

3. Press and release any button on the transmitter that you wish to program into the system. The horn will sound two times to indicate that the transmitter has been programmed.

Any additional transmitters can also be programmed at this time. Repeat steps 1 through 3 for an additional transmitter.

### **To exit the programming mode:**

1. After all of your transmitters are programmed, remove the key from the ignition switch.

The horn will sound three times to indicate that the system has exited the programming mode.

2. Make sure that the keyless entry system properly operates by operating each transmitter.

### **▽ Deleting old transmitter codes**

The control unit of the keyless entry system has four memory locations to store transmitter codes, giving it the ability to operate with up to four transmitters. When you lose a transmitter, the lost transmitter's code remains in the memory. For security reasons, lost transmitter codes should be deleted from the memory.

To delete old transmitter codes, program four transmitter codes into the system. If you have only one current transmitter, program it four times. If you have two current transmitters, program each one twice. If you have three current transmitters, program two of them once and the third one twice. This process will leave only current transmitter codes in the system's memory.

## **NOTE**

**Make sure no one else is operating their keyless entry system within range of your vehicle when programming transmitters. If someone else were to operate their remote transmitter while you are programming your transmitters, it is possible that their transmitter code will be programmed into your system, allowing them unauthorized access to your vehicle.**

---

## Security system (if equipped)

---

The security system helps to protect your vehicle and valuables from theft. The horn sounds and the parking lights flash if someone attempts to break into your vehicle. The starter motor is also interrupted to prevent starting the vehicle without a key.

The system can be armed and disarmed with the remote transmitter. The system does not operate when the key is inserted into the ignition switch.

### ▼ System operation

The security system will give the following alarm indications when triggered:

- The parking lights will flash and the horn will sound intermittently. In addition, the starter motor will not operate.
- The alarm automatically resets after 30 seconds; however, the alarm will reactivate if the vehicle is tampered with again. The alarm will continue for twelve times if any sensor continues to be activated.

The alarm is triggered by:

- Opening a door or the rear gate.
- Application of physical shock to the vehicle (e.g. breaking glass or forced entry). Note that there are two alarm levels for shock: warning and alarm. In warning mode, the alarm detects lower level vibrations and triggers 2 warning chirps on the horn and two flashes on the lights as a deterrent to would be vandals. In alarm mode, higher levels of shock are detected and the system will go into full alarm.
- Ignition switch being turned on while in armed state.

## ▼ Arming the system

### ▽ To arm the system using remote transmitter

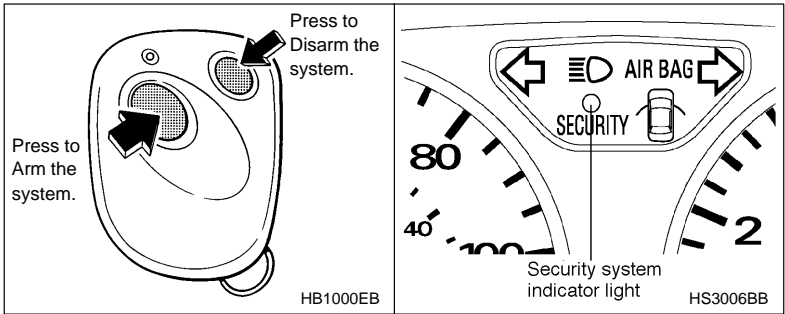

1. Close all windows and moonroofs (if so equipped).
2. Remove the key from the ignition switch.
3. Open the doors and get out of the vehicle.
4. Make sure that the engine hood is locked.
5. Close all doors and the rear gate.
6. Briefly press the "LOCK/ARM" button (for less than two seconds). All doors (and the rear gate) will lock, the horn will sound one time, the parking lights will flash one time and the indicator light starts flashing slowly (approximately once every two seconds).

If any of the doors or the rear gate is not fully closed, the horn sounds three times, the parking lights flash three times and the indicator light flashes rapidly to alert you that the doors or the rear gate are not properly closed. When you close the door, the system will automatically arm and doors will automatically lock.

---

▼ **To arm the system using power door locking switches**

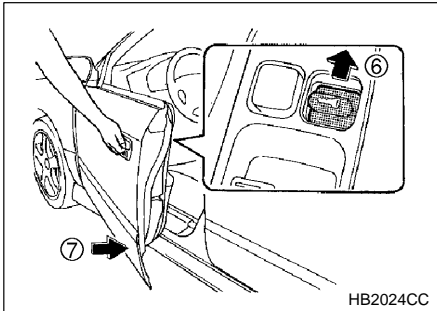

1. Close all windows and moonroofs (if so equipped).
2. Remove the key from the ignition switch.
3. Open the doors and get out of the vehicle.
4. Make sure that the engine hood is locked.
5. Close the doors (and the rear gate) but leave only the driver's door or the front passenger's door open.
6. Push the power door locking switch forward ("LOCK" side) to set the door locks.
7. Close the door. The horn will sound one time, the parking lights will flash one time and the indicator light will start flashing slowly (approximately once every two seconds) to inform you that the system has armed.

**NOTE**

**The system can be armed even if the engine hood, the windows and/or moonroofs are opened. Always make sure that they are fully closed before arming the system.**

▼ **Disarming the system**

Briefly press the "UNLOCK/DISARM" button (for less than two seconds) on the remote transmitter. The driver's door will unlock, the horn will sound two times, the parking lights will flash two times and the indicator light will go off.

To unlock all doors (and the rear gate), briefly press the “UNLOCK/DISARM” button a second time.

### ▽ **Emergency disarming**

If you cannot disarm the system using the transmitter (i.e. the transmitter is lost, broken or the transmitter battery is too weak), you can disarm the system without using the transmitter.

To disarm the system:

1. Unlock the door with the key and then open the door.
2. The alarm will sound.
3. Insert the key into the ignition switch and cycle it from the “LOCK” to the “ON” position three (3) times **within 5 seconds**.

### ▼ **Sounding a panic alarm**

To activate the alarm, keep the “LOCK/ARM” button pressed **for more than two seconds**.

To deactivate it, press the “LOCK/ARM” button or “UNLOCK/DISARM” button.

The parking lights will also flash when the alarm is activated.

Unless a button on the remote is pressed, the alarm will be deactivated after approximately 30 seconds.

### ▼ **Valet mode**

When you choose the valet mode, the security system does not operate. In valet mode, the remote transmitter is used only for locking and unlocking the doors (and rear gate) and panic activation.

To enter the valet mode, open the driver's door and keep the “UNLOCK/DISARM” button depressed **for more than two seconds**. The indicator light repeatedly flashes two times while the system is in valet mode.

To exit valet mode, open the driver's door and keep the “UNLOCK/DISARM” button pressed **for more than two seconds**. The indicator will stop flashing.

### ▼ Passive arming

When passive arming mode has been programmed by the dealer, arming of the system is automatically accomplished without using the remote transmitter. Note that in this mode, DOORS MUST BE MANUALLY LOCKED.

### ▽ To enter the passive mode

## ⚠ WARNING

**Do not disconnect or tamper with any yellow connector and/or any harness covered with yellow insulation and/or tape.**  
**Doing so could result in accidental inflation of the SRS airbag or could make the SRS airbag system inoperative, which may result in serious injury.**

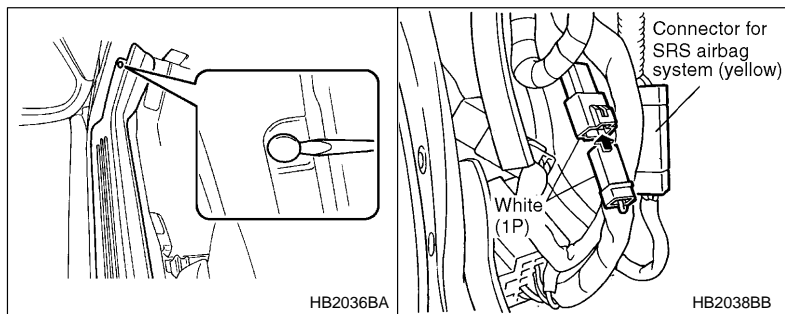

1. Remove the side sill cover on the driver's side.
  - 1) Open the driver's door.
  - 2) Remove the clip by prying the edge with screwdriver.
  - 3) Remove the side sill cover by pulling it up.
2. Connect the white (1 pole) connector.
3. Turn the ignition switch from the "LOCK" to the "ON" position.
4. Install the side sill cover.

To place the system in active arming mode (remote required for activation), disconnect the white connector.



### ▽ Arming the system

#### **⚠ CAUTION**

In passive mode, the system will automatically activate the alarm but **WILL NOT** automatically lock the doors. In order to lock the doors you must either lock them as indicated in step 4 below or with the key once they have been closed. Failure to lock the doors manually will result in a higher security risk.

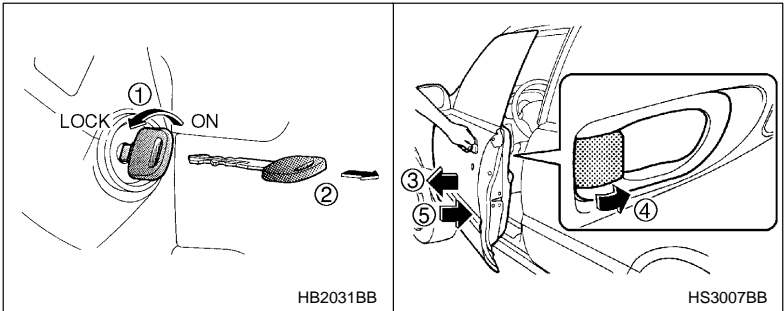

1. Turn the ignition switch to the "ON" position.
2. Turn the ignition switch from "ON" to "LOCK" position and remove the key from the ignition switch.
3. Open the doors and get out of the vehicle.
4. Before closing the doors, lock all doors with the inside door lock levers.
5. Close the doors. The system will automatically arm after one minute.

In the passive mode, the system can also be armed with the remote transmitter or with the power door locking switches. If the remote transmitter or power door lock switch is used to lock the vehicle, arming will take place immediately regardless of whether or not the passive mode has been selected.

---

### ▼ Disarming the system

To disarm the system, briefly press the "UNLOCK/DISARM" button on the transmitter.

### ▼ Tripped sensor identification

If the horn sounds four times and the parking lights flash four times when you disarm the system, this indicates that the alarm was triggered. The number of times the indicator light flashes indicates what sensor caused the alarm condition.

To enter identification mode:

1. Open the driver's door and leave it open.
2. Turn the ignition switch to the "ON" position two times. ("LOCK" → "ON" → "LOCK" → "ON" → "LOCK")
3. The indicator light will start flashing.

The indicator light provides the following indications.

**Flashing one time:** Any door or the rear gate has been opened.

**Flashing three times:** The impact sensor in the system's unit has been activated. This may indicate that your vehicle has been shocked or tampered with by some outside force and/or unauthorized person.

**Flashing four times:** The ignition switch has been turned on.

To exit this mode, close the door and turn the ignition switch to the "ON" position.

## Child safety locks

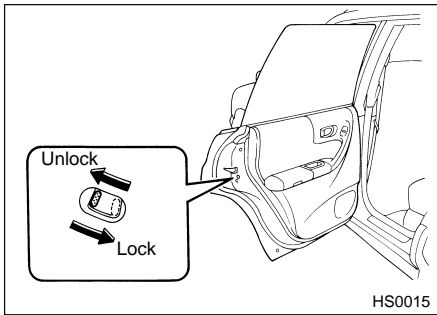

### **WARNING**

**Always use the child safety lock whenever a child rides in the rear seat. Serious injury could result if a child accidentally opened the door and fell out.**

Each rear door has a child safety lock that prevents the doors from being opened even if the inside door handle is pulled.

When the child safety lock lever is in the lock position, the door cannot be opened from inside regardless of the position of the inner door handle lock lever. The door can only be opened from the outside.

---

## Power windows

---

### **WARNING**

- When operating power windows, be extremely careful to prevent anyone's fingers, arms or head from being caught in the window.
- Always lock the passengers' windows using the lock switch when children are riding in the vehicle.
- Before leaving the vehicle, always remove the key from the ignition switch for safety and never allow an unattended child to remain in the vehicle. Failure to follow this procedure could result in injury to a child operating the power window.

The power windows operate only when the ignition switch is in the "ON" position.

#### ▼ Power window switch cluster (driver's side)

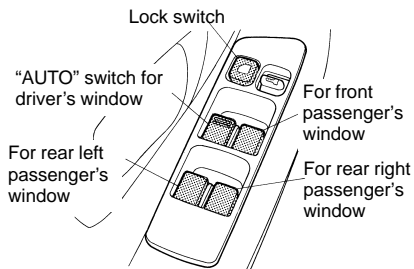

HS0017

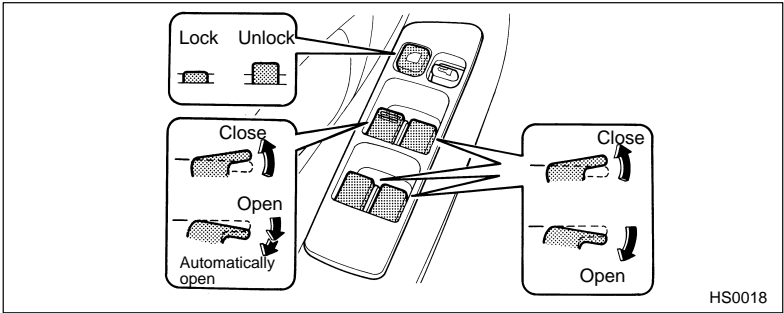

All door windows can be controlled by the power window switch cluster at the driver side door.

#### ▽ To open or close the driver's window

**AUTO switch:** This switch has two functions.

Push the switch down until it clicks and release it, and the window will fully open. To stop the window halfway, pull the switch up slightly.

Push the switch down lightly and hold it. The window will open as long as the switch is held.

Pull the switch up lightly and hold it. The window will close as long as the switch is held.

#### ▽ To open or close the passengers' windows

To open the passengers' windows, push the appropriate switch down and hold it until the window reaches the desired position. To close the window, pull the switch up and hold it until it reaches the desired position.

#### ▽ To lock the passengers' windows

To lock the passengers' windows, push the lock switch. When the lock switch is in the "LOCK" position, the passengers' windows cannot be opened or closed.

---

### ▼ Front passenger's switch

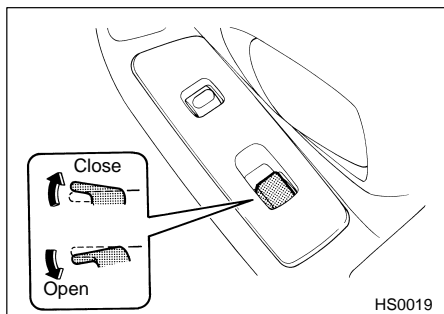

To open the window, push the switch down and hold it until the window reaches the desired position. To close the window, pull the switch up and hold it until the window reaches the desired position.

When the lock switch on the power window switch cluster, located on the driver's side door, is in the "LOCK" position, the front passenger's window cannot be operated with the front passenger's switch.

### ▼ Rear passenger's switches

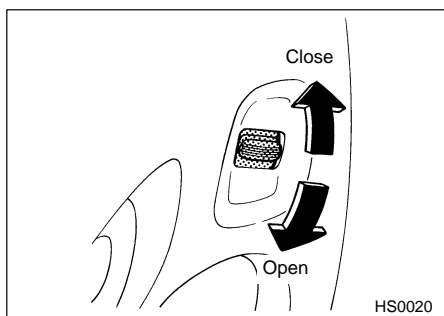

To open the window, push the switch down and hold it until the window reaches the desired position. To close the window, push the switch up and hold it until the window reaches the desired position.

When the lock switch on the power window switch cluster, located on

the driver's side door, is in the "LOCK" position, the rear passengers' windows cannot be operated with the rear passengers' switches.

## Rear gate



### WARNING

- Do not attempt to shut the rear gate while holding the inside handle. Also avoid closing the rear gate by pulling on the inside handle from inside the cargo space. There is a danger of your hand being caught and injured.
- To prevent dangerous exhaust gas from entering the vehicle, always keep the rear gate closed while driving.

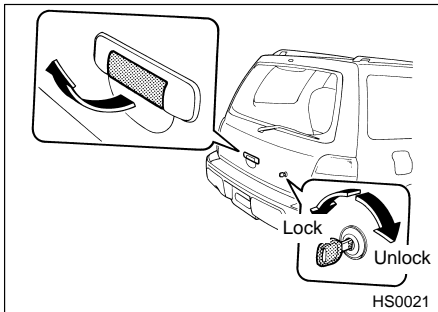

To unlock the rear gate, insert the key in the keyhole and turn it clockwise. To lock the rear gate, insert the key in the keyhole and turn it counterclockwise. Since your vehicle is equipped with power door locks, the rear gate can also be locked and unlocked by operating the driver's door lock.

To open the rear gate, first unlock the rear gate lock then pull the outside handle up.

To close the rear gate, lower it slowly and push down firmly until the latch engages. The rear gate can be lowered easily if you pull down on the inside handle as shown in the illustration.

– CONTINUED –

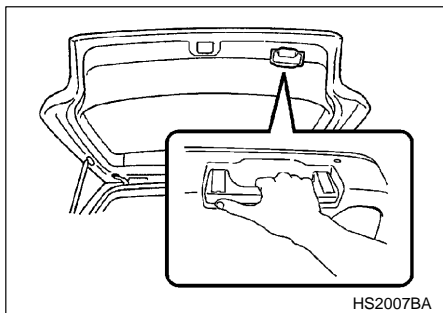

## Moonroof (if equipped)

---

### **WARNING**

- Never let anyone's hands, arms, head or any objects protrude from the moonroof.
- Before closing the moonroof, make sure that no one's hands, arms, head or other objects will be accidentally caught in the moonroof.

### **CAUTION**

- Do not sit on the edge of the open moonroof.
- Do not operate the moonroof if falling snow or extremely cold conditions have caused it to freeze shut.

The moonroof operates only when the ignition switch is in the "ON" position.



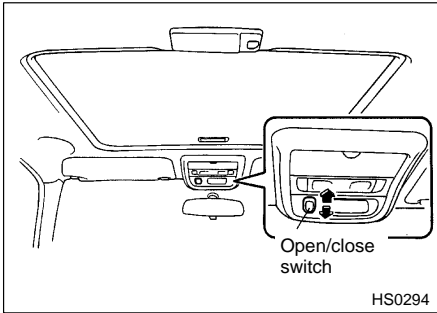

### **To open or close the moonroof**

Push the upper part of the switch to open the moonroof. The sun shade also will be opened together with the moonroof. The moonroof will stop at a position 20 in. (50 cm) away from the fully closed position if you continue to press on the switch. Release the switch once and push it again to open the moonroof completely.

Push the lower part of the switch to close the moonroof. The moonroof will stop at a position 6 in. (15 cm) away from the fully closed position if you continue to press on the switch. Release the switch once and push it again to close the moonroof completely.

After washing the vehicle or after it rains, wipe away water on the roof prior to opening the moonroof to prevent water drops from falling into the passenger compartment.

### **NOTE**

- **For the sake of safety, it is recommended that you avoid driving with the moonroof opened beyond the initial stop position of 20 in. (50 cm).**
- **Driving with the moonroof fully open can cause an annoying sound to generate at high speeds. If such a condition has been encountered, close the moonroof up to the initial stop position of 20 in. (50 cm).**
- **If the moonroof cannot be closed through switch operation because of system failure, it can be closed manually using a hex-**

– CONTINUED –

---

head wrench. For the procedure, refer to “Moonroof — if the moonroof cannot be closed” in Chapter 9 “In case of emergency”.

▼ Sun shade

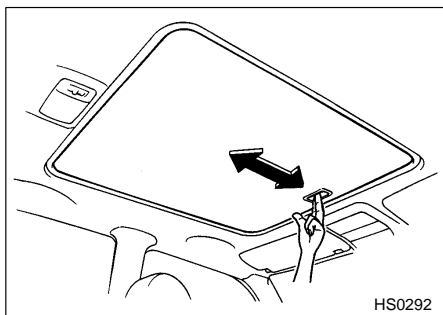

The sun shade can be slid forward or backward by hand while the moonroof is closed.

If the moonroof is opened, the sun shade also moves back.