

YOUR 307 SW AT A GLANCE

1

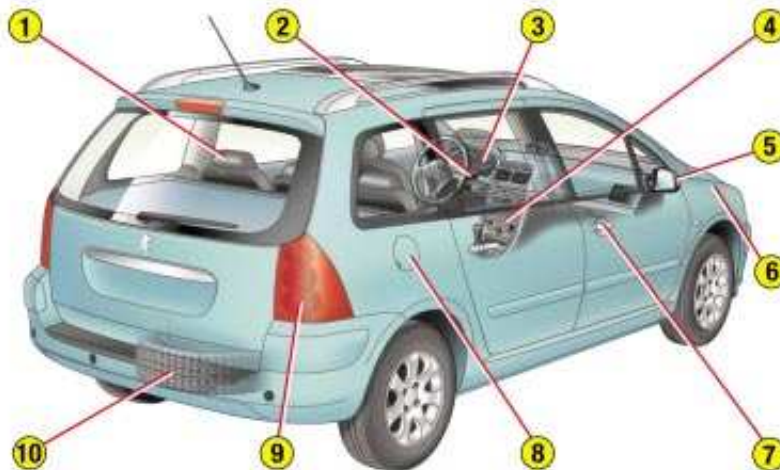

	Pages
1 Seats	88-102
2 Steering wheel controls	110-116
3 Instrument dials	28-29
4 Ventilation, air conditioning	82-87
5 Mirrors	118-119



6 Checks	136-140
7 Access	103-109
8 Fuel filler flap	109
9 Changing a bulb	145-147
10 Changing a wheel	141-144

Each model may only be fitted with some of the equipment shown, according to its specification and the technical requirements in the country of first registration of the vehicle.

YOUR 307 SW AT A GLANCE

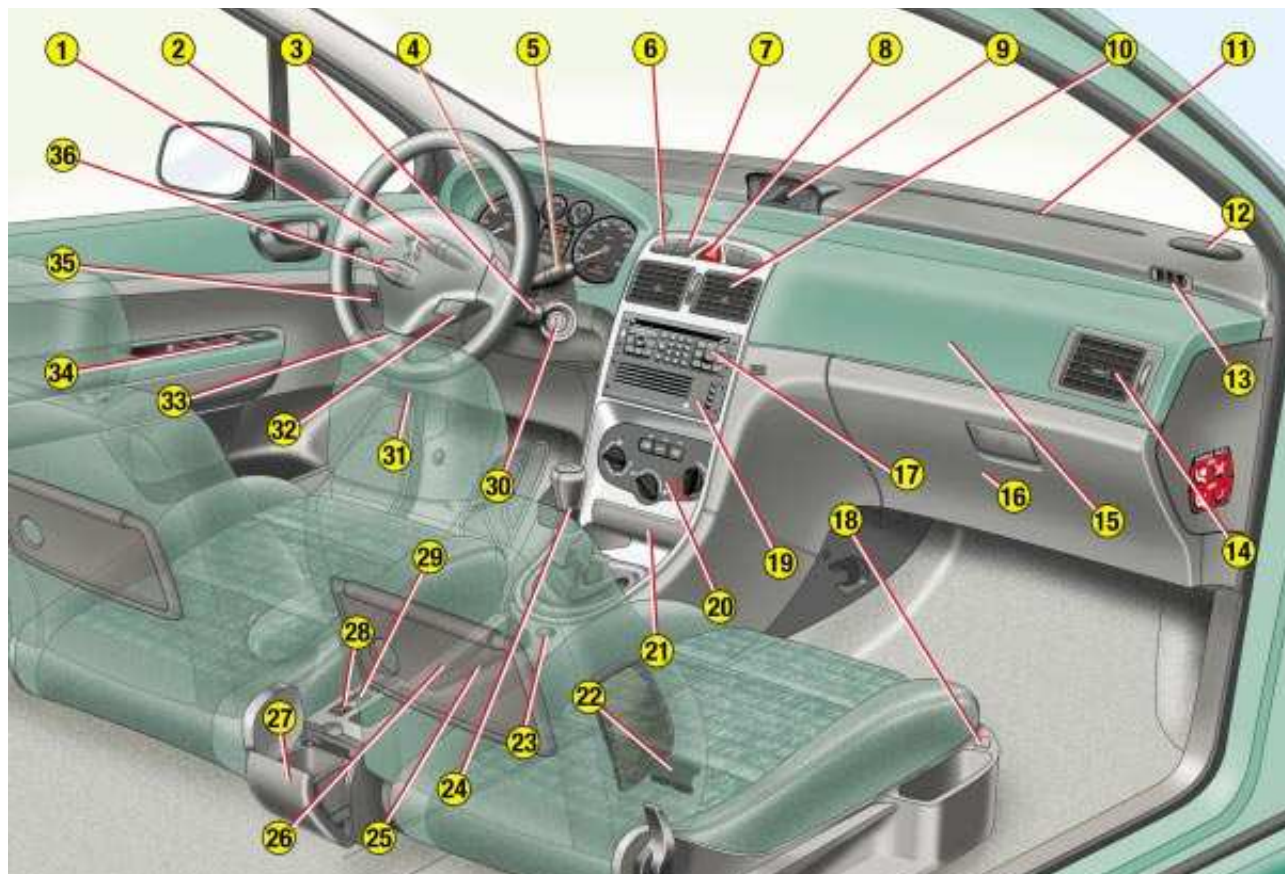

YOUR 307 SW AT A GLANCE



- 1 - Driver's air bag.
Horn.
- 2 - Lights and direction indicators stalk.
- 3 - Audio remote control stalk.
- 4 - Instrument dials.
- 5 - Windscreen wash-wipe stalk.
Trip computer stalk.
- 6 - Alarm button.
- 7 - Central locking button.
- 8 - Hazard warning lights switch.
- 9 - Multi-function display.
- 10 - Central adjustable ventilation and air flow regulation vents.
- 11 - Windscreen demisting vents.
- 12 - Speaker (tweeter) location.
- 13 - Side window demisting vent.
- 14 - Side adjustable ventilation and air flow regulation vent.
- 15 - Passenger air bag.
- 16 - Glove box.
- 17 - RB3, RD3 or RT3 audio equipment.
- 18 - Heated seat switches.
- 19 - CD changer.
- 20 - Ventilation / air conditioning controls.
- 21 - Front ashtray.
- 22 - Rear footwell heating vent.
- 23 - 12 V accessories socket.
- 24 - Gear lever.
- 25 - Can holder.
- 26 - Handbrake.
- 27 - Waste container.
- 28 - Passenger air bag disarming switch*.
- 29 - Panoramic roof concealing flap control.
- 30 - Steering lock and ignition.
- 31 - Bonnet opening control.
- 32 - Steering wheel adjustment control.
- 33 - Fuse box.
- 34 - Electric mirror controls.
Window controls.
Rear window locking control.
- 35 - Headlamp height adjustment.
- 36 - Cruise control

* According to destination



THE KEYS

The keys allow you to switch on the ignition and to independently operate the front doors, the fuel filler cap, the glove box and the passenger air bag disarming switch.

Central locking

From the driver's door, the keys allow you to lock, deadlock or unlock the doors and the tailgate and to fold back the exterior mirrors.

If one of the doors or the boot is open, it is impossible to operate the central locking; an audible signal indicates locking by remote control.

The remote control performs the same functions at a distance.

YOUR 307 SW AT A GLANCE

The remote control key

Locking

Press button **A** to lock the vehicle. This is confirmed by fixed lighting of the direction indicators for approximately two seconds.

Note : a long press on button **A**, in addition to deadlocking, automatically closes the windows.

Vehicles fitted with deadlocking



Deadlocking renders the internal and external door locking controls inoperative.

Press button **A** to deadlock the vehicle.

This is confirmed by fixed lighting of the direction indicators for approximately two seconds.

Note : a long press on button **A** permits automatic closing of the windows, in addition to deadlocking.

A second press on button **A** in the five seconds following deadlocking, changes deadlocking to normal locking.

This is confirmed by fixed lighting of the direction indicators for approximately two seconds.

Unlocking

Press button **B** to unlock the vehicle.

This is confirmed by rapid flashing of the direction indicators.

Note : If the vehicle is locked and unlocking is activated inadvertently without the doors being opened within 30 seconds, the vehicle will re-lock automatically.



STARTING

STOP position: the ignition is off.

1st notch, Accessories position: the ignition is off but the accessories can be used.

2nd notch, Running position: the ignition is on.

Starting position: operates the starter.





STEERING WHEEL STALKS

LIGHTING

Front and rear lights (ring A)



Lights off.



Side lights.



Dipped / main beam headlamps.



Automatic switching on of lights

Automatic switching on of lights

To activate or disarm the function, place the key in the accessories position, the lights stalk in position **0** and press the end of the lights stalk for more than two seconds.



Vehicles fitted with a rear fog lamp (ring B)



Rear fog lamp (rotation of the ring forwards)

Vehicles fitted with front fog lamps and a rear fog lamp (ring C)



Front fog lamps (first rotation of the ring forwards)



Front fog lamps and rear fog lamp (second rotation of the ring forwards)

Switching off: rotation of the ring rearwards.



WINDSCREEN WIPERS

Front

- 2 Rapid wipe
- 1 Normal wipe
- I Intermittent wipe

or

- AUTO** Automatic wipe
- 0 Off
- ↓ Single wipe

Wash-wipe: pull the stalk towards you.

Automatic wipe

In the **AUTO** position, the wiper operates automatically and **adjusts its speed to the intensity of the rainfall.**



Rear

- Off
- Intermittent wipe
- Wash-wipe





FRONT SEATS

- 1- Forwards-backwards adjustment.
- 2- Seat back angle adjustment.
- 3- Driver or passenger seat height adjustment.
- 4- Heated seats switch.
- 5- Front removable armrest.
- 6- Head restraint height and angle adjustment

To raise or lower the head restraint, pull it forwards, sliding it at the same time.



Never drive with the head restraints removed.

- 7- Storage drawer.
- 8- "Aircraft" type table.



REAR SEATS

Manoeuvring a side seat:

- forwards-backwards adjustment (1),
- seat back angle adjustment (2),
- head restraint height adjustment (3),
- folding (4),
- removal/refitting (5).



Manoeuvring a centre seat:

- forwards-backwards adjustment (1),
- seat back angle adjustment, table position (2),
- head restraint height adjustment (3),
- folding (4),
- removal/refitting (5).



Manoeuvring an additional seat:

- seat back angle adjustment (1),
- head restraint height adjustment (2),
- folding (3),
- removal/refitting (4).

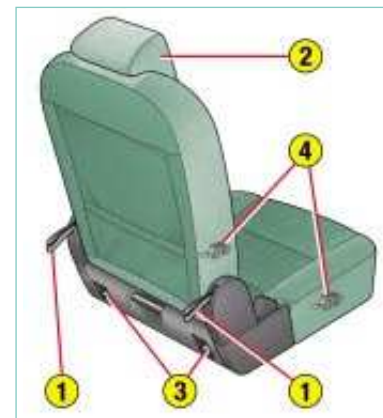

YOUR 307 SW AT A GLANCE

SEAT MODULARITY AND CONFIGURATIONS

5 seats



5 seats with centre seat in row 3

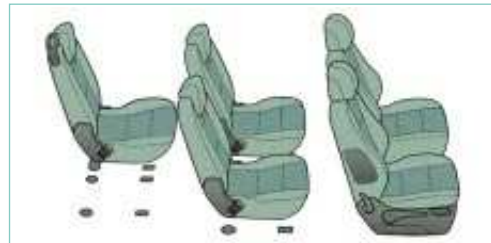

6 seats with one additional seat



7 seats with two additional seats

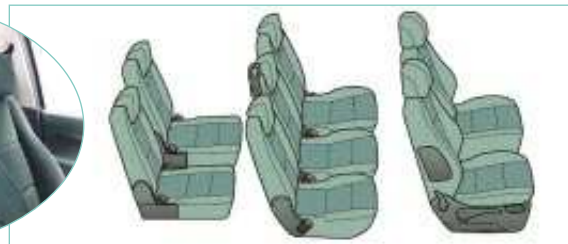

Transportation of long objects with table position

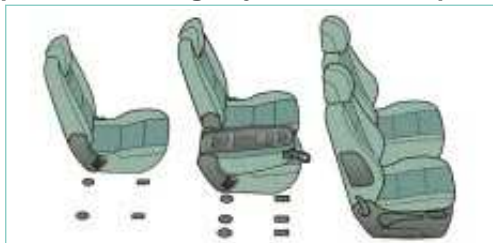

Loading of a large volume

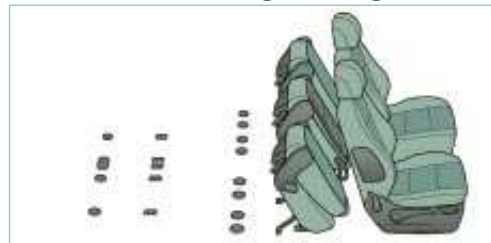

AIR BAGS

The air bag system has been designed to maximise the safety of the occupants in the event of serious collisions. It works in conjunction with the force limiting seat belts.

Front air bags

These are folded in the centre of the steering wheel for the driver and in the fascia for the front passenger. They are deployed simultaneously, except in cases where the passenger air bag is disarmed.

Precautions regarding the passenger air bag

- ☞ disarm the air bag if you install a rear facing child seat,
- ☞ activate the air bag for an adult passenger.

Disarming the passenger air bag*

- ☞ with the ignition off, insert the key into slot **1** and turn the passenger air bag switch to the **"OFF"** position.

As soon as you remove the child seat, turn the air bag switch to the **"ON"** position, to activate the air bag again.



Operating check



With the ignition switched on (2nd notch), illumination of the warning light, accompanied by an audible signal and the message **"Passenger air bag disarmed"** on the multi-function display, indicates that the passenger air bag is disarmed (switch in the **"OFF"** position).

The warning light remains on throughout the disarming process.

Side air bags* and curtain air bags*

Side air bags are incorporated into the front seat back frame, on the door side.

Curtain air bags are incorporated into the door pillars and the top of the passenger compartment.

They are deployed independently of each other, depending on which side the collision occurs.



133



134

* According to country.

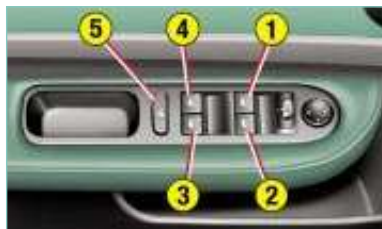

ELECTRIC WINDOWS

- 1 - Driver's electric window
- 2 - Passenger's electric window.
- 3 - Rear right electric window.
- 4 - Rear left electric window.
- 5 - Disarming the rear window switches.

Manual operation:

- ☞ Press or pull the switch lightly. The window stops as soon as the switch is released.



Automatic operation:

- ☞ Press or pull the switch firmly. One touch completely opens or closes the window.

Safety auto-reverse: When the window is closing and meets an obstacle, it stops and lowers again.

ELECTRIC MIRRORS

- ☞ Slide button 6 to the right or left to select the corresponding mirror.
- ☞ Then move button 7 in all four directions to adjust.
- ☞ Move button 6 back to the centre position.

When parking the vehicle, the mirrors can be folded back manually, electrically by pulling button 6 rearwards or automatically on locking the vehicle.



STEERING WHEEL HEIGHT AND DEPTH ADJUSTMENT

- ☞ When stationary, pull handle A to unlock the steering wheel.
- ☞ Adjust the height and depth of the steering wheel.
- ☞ Lock it by pushing handle A in fully.





FILLING WITH FUEL

This operation must be carried out with **the engine switched off**. The fuel to be used is indicated on the inside of the flap.

The capacity of the tank is approximately 60 litres.

On filling, do not continue after the third cut-off of the pump to avoid any malfunction.

Low fuel level

From the time this light comes on, the range remaining is approximately 30 miles (50 km).



OPENING THE BONNET



Inside the vehicle: Push the handle on the left side, under the fascia.



Outside the vehicle: Lift the catch, raise the bonnet and secure the strut to keep the bonnet open.

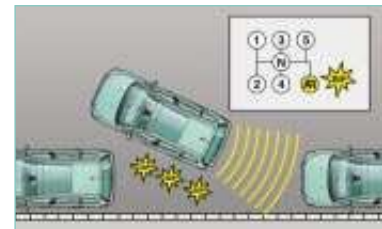

REAR PARKING ASSISTANCE

This system, installed in the rear bumper, detects any obstacle (person, vehicle, tree, barrier, ...) situated behind the vehicle.

Activation

With the engine running, the system is activated when reverse gear is engaged. A bleep indicates that it is active.

The proximity information is provided by an audible signal, consisting of bleeps which become faster as the vehicle approaches the obstacle.

When the distance between the rear of the vehicle and the obstacle is less than approximately twenty-five centimetres, the audible signal becomes continuous.

Change to neutral to disarm the system.





AUTOMATIC GEARBOX "PORSCHE TIPTRONIC SYSTEM"

The four speed **automatic** gearbox offers a choice between the comfort of **automatic integral** regulation enhanced by a **sport** and **snow programme**, or the pleasure of **manual gear changing**.

Gear selection gate

☞ Move the lever in the gate to select one of the functions.

Once the function is selected, the indicator light for that function is displayed on the instrument panel screen.

S: sport programme.

❄: snow programme.

Park: to **immobilise the vehicle** or to **start the engine**, with the handbrake on or off.

Reverse: to **reverse** (select this function with the vehicle stationary and the engine at idle).

Neutral: to **start the engine** or to **park**, with the handbrake on.

Note: if position **N** is engaged by mistake while the car is moving, allow the engine to return to idling speed before engaging function **D** to accelerate.

Drive: for **automatic** gear changing.

Manual: for **manual** gear changing.

To change the **four gears** manually:

☞ Push the lever to the **+** symbol to change up to the next gear and pull it towards the **-** symbol to change down a gear.

Note: the **S** (sport) and ❄ (snow) programmes do not operate in manual mode.

Moving Off

With the engine running, to move off from position **P**:

☞ **It is essential to press the brake pedal to exit position P,**

☞ Select function **R, D** or **M**, then gradually release the pressure on the brake pedal; the vehicle will move off immediately.

You can also move off from position **N**:

☞ Release the handbrake, with your foot on the brake.

☞ Select function **R, D** or **M** then gradually release the pressure on the brake pedal; the vehicle will move off immediately.



*When the engine is idling with the brakes not applied, if function **R, D** or **M** is selected, the vehicle moves without the accelerator being pressed.*

For this reason, **do not leave children unsupervised inside the vehicle, with the engine running.**



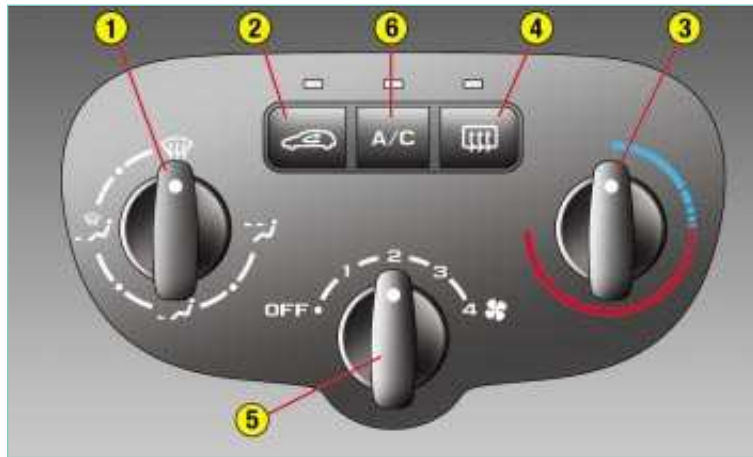

AIR CONDITIONING

N°	Symbol	Function
1		Setting the air distribution.
2		Air intake control.
3		Temperature adjustment.
4		Demisting the rear screen and mirrors.
5		Air flow adjustment.
6		Air conditioning control.



AUTOMATIC AIR CONDITIONING

N°	Symbol	Function
1		Air flow adjustment.
2		Setting the air distribution.
3		Air intake control.
4		Air conditioning control.
5		Demisting the rear screen and mirrors.
6		Switching off.
7		Temperature adjustment.
8		Automatic comfort programme.
9		Automatic visibility programme.

PEUGEOT SERVICING

PEUGEOT SERVICING

Your vehicle benefits from extended service intervals.

- For petrol engines: every 20,000 miles (30 000 km) or every two years.
- For direct injection diesel engines: every 12,000 miles (20 000 km) or every two years.

The extension of the service intervals means that the engine oil level must be checked regularly: topping up of the oil between oil changes is normal.

It is for this reason that the PEUGEOT network invites you to an intermediate visit between regular services.

The date of this service is not shown by the service indicator. It is to be carried out at least every 10,000 miles (15 000 km) for petrol engines and every 6,000 miles (10 000 km) for direct injection diesel engines.

A Peugeot dealer will carry out a quick check, and will top up the levels if necessary (oil, coolant, screenwash up to 2 litres).

If the oil level is too low there is a risk of serious damage to the engine: check the engine oil level at least every 2,000 miles (3 000 km) or 3,000 miles (5 000 km), depending on the conditions of use.

The extended service intervals have been made possible by technical modifications to the vehicles and lubricants:

THUS IT IS ESSENTIAL TO ONLY USE ENGINE LUBRICANTS WHICH ARE RECOMMENDED BY THE MANUFACTURER

PEUGEOT SERVICING

SERVICE INDICATOR

This indicates when the next service is due in accordance with the manufacturer's servicing schedule.

Operation

For 5 seconds after the ignition is switched on, the spanner symbolising the servicing operations comes on; the distance recorder display indicates the number of miles [kilometres] (rounded off) remaining until the next service.

Example: 4,800 km remain before the next service. For five seconds after the ignition is switched on, the display indicates:



5 seconds after the ignition was switched on, the distance recorder resumes its normal operation and the display indicates the total and trip distance.



The distance remaining to the next service is less than 1,000 km.

Example: 900 km remain before the next service.

For 5 seconds after the ignition is switched on, the indicator displays:



5 seconds after the ignition was switched on, the distance recorder resumes its normal operation and the spanner remains lit.

It indicates that a service must be carried out soon. The display indicates the total and trip distance.

The service is overdue.

The service spanner flashes for 5 seconds after the ignition is switched on.

Example: the service is overdue by 300 km, your vehicle must be serviced as soon as possible.

For 5 seconds after the ignition is switched on, the display indicates:



5 seconds after the ignition was switched on, the distance recorder resumes its normal operation and the service spanner remains lit. The display indicates the total and trip distance.

PEUGEOT SERVICING

Zero re-set

Your PEUGEOT dealer carries out this operation after each service.

However, if you carry out the service yourself, the re-set procedure is as follows:

- ☞ Switch off the ignition,
- ☞ Press and hold the trip recorder re-set button,
- ☞ Switch on the ignition.

The display begins a countdown.

When the display shows 0, release the button; the service symbol disappears.

Important: after this operation, if you wish to disconnect the battery, lock the vehicle and wait for at least five minutes, otherwise the zero re-set will not be registered.

MAINTENANCE OF PARTS SUBJECT TO WEAR and a check of consumables

Certain essential components on your vehicle are subject to checks at specific frequencies:

- The **brake fluid** is to be replaced at a maximum of **every 36,000/40,000 miles (60 000 km)** or every two years.
- The **passenger compartment filter** must be checked **at each service** by a PEUGEOT dealer (services and intermediate visits) or **more often**, depending on the environment (dust, pollution, etc.)
- Replacement of the **timing belt**: consult a PEUGOT dealer.
- For the **2 litre HDI turbo diesel engine (110 bhp)**, maintenance of the **particulate emission filter** and topping up of the additive reservoir must be carried out **at a maximum of every 72,000 miles (120 000 km)**, by a PEUGEOT dealer.
- **Air bags** and **pretensioning parts** on seat belts must be checked **every 10 years**.
- The check on **tyre inflation pressure** must be carried out cold at least **once a month**.

PEUGEOT SERVICING

THE SERVICE LEVELS















Each vehicle has its own servicing cycle, based upon the engine type.

This cycle consists of alternating 2 types of service, A and C, intermediate visits and a few additional operations specific to your vehicle; these correspond to key stages in the life of your 307 SW.

At your first and each subsequent service, your dealer will advise you of the type and content of the next service due.

MAINTENANCE CYCLE FOR YOUR 307 SW PETROL ENGINE

Service every 2 years or 20,000 miles (30 000 km) maximum

MILES (KM)		20,000 (30 000)	40,000 (60 000)	60,000 (90 000)					
1st service at 6,000 miles (10 000 km) or 6 months*. This is necessary in order to benefit from the warranty.									
80,000 (120 000)	100,000 (150 000)	120,000 (180 000)	140,000 (210 000)	160,000 (240 000)					
									

These services are to be carried out with **synthetically based oil**.

Synthetic oil or **Fuel economy oil** may also be used.

Arduous conditions of use (see corresponding section).



























Intermediate top-up visit included in the Fixed Services.

* Whichever comes first.

PEUGEOT SERVICING

MAINTENANCE CYCLE FOR YOUR 307 SW DIESEL

Service every 2 years or 12,000 miles (20 000 km) maximum

MILES (KM)		12,000 (20 000)	24,000 (40 000)	36,000 (60 000)	48,000 (80 000)	60,000 (100 000)	72,000 (120 000)	84,000 (140 000)	96,000 (160 000)	108,000 (180 000)	120,000 (200 000)	132,000 (220 000)	144,000 (240 000)		
1st service at 6,000 (10 000 km) or 6 months* . This is necessary in order to benefit from the warranty.															
															
+ maintenance of particulate emission filter 2,0 l HDI 110 bhp												+ maintenance of particulate emission filter for engine 2,0 l HDI 110 bhp			

These services are to be carried out:

- **imperatively** with **5W40 synthetic oil** for the **HDI Turbo Diesel engines** fitted with a **particulate emissions filter**,
- with **synthetically based oil, synthetic oil or Fuel Economy oil** for the **other HDI Turbo Diesel engines**.

Arduous conditions of use (see corresponding section).



Intermediate top-up visit included in the Fixed Services.

* Whichever comes first.

PEUGEOT SERVICING

Arduous conditions of use

- Continuous door-to-door use.
- Town use (e.g. taxi).
- Repeated short journeys, with the engine cold at low temperatures.
- A prolonged stay under the following conditions :
 - countries with temperatures often above +30 °C,
 - countries with temperatures often below -15 °C,
 - countries with a dusty atmosphere,
 - countries whose lubricants or fuels do not conform to our recommendations.

PEUGEOT SERVICING

A AND C SERVICE LEVELS AND THE INTERMEDIATE VISIT

Operations	Description of operation	1st service	Level		
			A	C	Intermediate
DRAIN/REFILL	- Engine oil	●	●	●	
	- Bleed fuel filter (diesel)	●	●	●	
REPLACE	- Oil filter		●	●	
	- Fuel filter* (petrol)			●	
	- Fuel filter element (diesel)			●	
	- Air filter element			●	
	- Spark plugs (petrol)			●	
LEVEL	- Engine oil (check + top-up)	●			●
	- Manual gearbox oil (check + top-up)	●		●	
	- Battery (check + top-up) if cap is removable		●	●	
	- Screen wash front/rear (check + top-up)	●	●	●	
	- Coolant (check + top-up)	●	●	●	●
	- Brake fluid (check + top-up)	●	●	●	
	- Power steering fluid (check + top up according to specification)	●	●	●	
CHECK	- Operation of lights and indicators	●	●	●	
	- Condition of glass, headlamp and light lenses and mirrors		●	●	
	- Horn		●	●	
	- Windscreen washer jets		●	●	
	- Condition of wiper blades		●	●	
	- Condition and tension of the ancillary drive belts		●	●	
	- Handbrake		●	●	
	- Condition of hydraulic circuits (hoses and covers)		●	●	
	- Condition of rubber boots and gaiters	●	●	●	
	- Brake pads		●	●	○
	- Play in hubs, link rods, ball joints, flexible mountings		●	●	
	- Shock absorbers		●	●	
	- Rear drum brake lining wear		●	●	
	- Condition and pressure of tyres (including spare wheel)	●	●	●	
	- Emission control check as per current legislation (petrol)	●	●	●	
	- Smoke opacity (diesel)	●	●	●	
- Passenger compartment filter (according to specification)		●	●	○	
- Visual check of the whole vehicle	●			●	
SERVICE*	- Courtesy vehicle			●	
ROAD TEST			●	●	

● : All driving conditions.

○ : Arduous conditions.

* According to destination.



TRADE NAMES OF APPROVED AND RECOMMENDED ENGINE LUBRICANTS IN EUROPE (1)



(1) Minimum grade: Petrol engines ACEA A3 and API SH/SJ; Diesel engines: ACEA B3 and API CF/CD

ACEA = Association des Constructeurs Européens Automobiles (Association of European Automobile Manufacturers) -
API = American Petroleum Institute.

If oil is used which does not conform to the ACEA A3-B3 standards, this requires the "Arduous Conditions" servicing schedule to be followed, which involves shorter intervals between services.

* This Fuel Economy oil can only be used in engines designed for its use.

Use 5W40 synthetic oil only for HDI Turbo Diesel engines fitted with a particulate emission filter.

PEUGEOT SERVICING

Recommendations for approved lubricants

The oils which appear in the table opposite are suitable for most purposes.

The diagram opposite states the optimum range of viscosity depending on the temperatures at which the oils are to be used.

It is also possible to use "superior quality" synthetic oils.

In the absence of semi-synthetic or synthetic oils, oils of API SH/SJ quality (for petrol engines), or CD/CF quality (for diesel engines) may be used by following the "Arduous Conditions" servicing schedule, which specifies shorter intervals.

Do not hesitate to ask for advice from a PEUGEOT dealer to maintain driving pleasure and to minimise the maintenance cost of your vehicle.

For countries outside Europe, please contact a local PEUGEOT dealer.

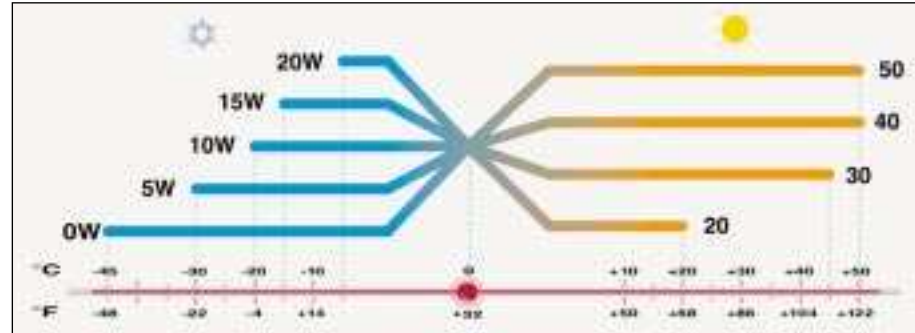

		
Manual Gearbox	ONLY ESSO GEAR OIL BV 75W80 PR 9736.41	ONLY TOTAL TRANSMISSION BV 75W80
Automatic Gearbox	ONLY ATF 4HP20-AL4 PR 9736.22	

Other recommended products

Power steering	FLUIDE DA PR 9730.A1
Brake fluid	PEUGEOT DOT4
Coolant	PROCOR TM108/GLYSANTIN G33 or REVKOGEL 2000 ONLY Protection to minus 35C

INSTRUMENTS AND CONTROLS



PETROL / DIESEL INSTRUMENT PANEL DIALS: MANUAL GEARBOX

- | | | |
|---|--|---|
| <p>1 - Rev counter.</p> <p>2 - Seat belt not fastened warning light.</p> <p>3 - Engine diagnostics warning light.</p> <p>4 - Handbrake and low brake fluid level warning light.</p> <p>5 - Left-hand direction indicator.</p> <p>6 - Coolant temperature indicator.</p> | <p>7 - Battery charge warning light.</p> <p>8 - Central (STOP) warning light.</p> <p>9 - Engine oil pressure warning light.</p> <p>10 - Low fuel level warning light.</p> <p>11 - Right-hand direction indicator.</p> <p>12 - Fuel gauge.</p> <p>13 - ABS warning light.</p> | <p>14 - Air bag warning light.</p> <p>15 - Passenger air bag disarming indicator light.</p> <p>16 - Speedometer.</p> <p>17 - Service indicator, oil level and total distance recorder.</p> <p>18 - Trip recorder zero reset.</p> <p>19 - Rear fog lamp indicator light.</p> <p>20 - ESP/ASR warning light.</p> <p>21 - Front fog lamps indicator light.</p> <p>22 - Diesel engine preheating light.</p> <p>23 - Main beam headlamps indicator light.</p> <p>24 - Low coolant level warning light.</p> <p>25 - Dipped beam headlamps indicator light.</p> <p>26 - Water in diesel filter warning light.</p> <p>27 - Lighting rheostat.</p> |
|---|--|---|

INSTRUMENTS AND CONTROLS



PETROL INSTRUMENT PANEL DIALS: AUTOMATIC GEARBOX

- | | | |
|---|--|---|
| <p>1 - Rev counter.</p> <p>2 - Seat belt not fastened warning light.</p> <p>3 - Engine diagnostics warning light.</p> <p>4 - Handbrake and low brake fluid level warning light.</p> <p>5 - Left-hand direction indicator.</p> <p>6 - Coolant temperature indicator.</p> | <p>7 - Battery charge warning light.</p> <p>8 - Central (STOP) warning light.</p> <p>9 - Engine oil pressure warning light.</p> <p>10 - Low fuel level warning light.</p> <p>11 - Right-hand direction indicator.</p> <p>12 - Fuel gauge.</p> <p>13 - ABS warning light.</p> | <p>14 - Air bag warning light.</p> <p>15 - Passenger air bag disarming indicator light.</p> <p>16 - Speedometer.</p> <p>17 - Service indicator, oil level and total distance recorder.</p> <p>18 - Trip recorder zero reset.</p> <p>19 - Rear fog lamp indicator light.</p> <p>20 - ESP/ASR warning light.</p> <p>21 - Front fog lamps indicator light.</p> <p>22 - Main beam headlamps indicator light.</p> <p>23 - Low coolant level warning light.</p> <p>24 - Dipped beam headlamps indicator light.</p> <p>25 - Lighting rheostat.</p> <p>26 - Sport programme indicator light.</p> <p>27 - Snow programme indicator light.</p> <p>28 - Gear lever position indicator.</p> |
|---|--|---|

INSTRUMENTS AND CONTROLS

INSTRUMENTS AND CONTROLS

AA permanently lit warning light or one that flashes with the engine running, indicates an operating fault in the relevant unit. Some warning lights may be linked to buzzers and a message on the multi-function display. Do not ignore this warning: contact a PEUGEOT dealer as soon as possible. If the Central STOP warning light comes on when you are driving, stop immediately where it is safe to do so.



Central STOP warning light

This light comes on each time the ignition is switched on.

It is linked to the "engine oil pressure", "oil temperature", "coolant level low", "brake fluid level", "electronic brake force distribution fault" and "coolant temperature gauge" warning lights.

Stop immediately if it flashes with the engine running.

Contact a PEUGEOT dealer.



Engine oil pressure warning light

Linked to the central **STOP** warning light.

If it comes on with the engine running, it is accompanied by an audible signal and the message "**Oil pressure low**" or "**Top up engine oil**" on the multi-function display.

Stop immediately.

If there is a lack of oil in the lubrication circuit, top up the level.

Contact a PEUGEOT dealer without delay.



Low coolant level warning light

Linked to the central **STOP** warning light.

This comes on for approximately 3 seconds each time the ignition is switched on.

This warning light is accompanied by an audible signal and the message "**Top up coolant**" on the multi-function display.

Stop immediately.

Warning: Allow the engine to cool before topping up.

The cooling system is pressurised.

To prevent the risk of scalding, unscrew the cap by two turns to allow the pressure to drop.

Once the pressure has dropped, remove the cap and top up the level.

Contact a PEUGEOT dealer.



Handbrake and low brake fluid level warning light

Linked to the central **STOP** warning light.

This comes on each time the ignition is switched on.

Illumination of this light is accompanied by an audible signal and a message on the multi-function display indicating the cause of the warning:

- "**Handbrake on**", if the handbrake is applied or has not been released correctly,
- "**Low brake fluid level**" if there is an excessive drop in the brake fluid (if the light remains on even with the handbrake released),
- "**Brake system problem**" is displayed simultaneously with the ABS light, indicating a malfunction of the electronic brake force distribution.

Stop immediately.

Contact a PEUGEOT dealer.

INSTRUMENTS AND CONTROLS



Battery charge warning light

This comes on each time the ignition is switched on.

If it comes on with the engine running, it is accompanied by an audible signal and a message **"Low battery charge"** on the multi-function display.

It can indicate:

- faulty operation of the charging circuit,
- loose battery or starter terminals,
- a cut or slack alternator belt,
- an alternator fault.

Contact a PEUGEOT dealer.



ABS warning light

This light comes on for 3 seconds each time the ignition is switched on.

If it remains on or comes on above 8 mph (12 kmh), this indicates a malfunction of the ABS.

However, the vehicle retains conventional servo-assisted braking.

Illumination of this light is accompanied by an audible signal and the message **"ABS system problem"** on the multi-function display.

Contact a PEUGEOT dealer.



Electronic stability programme (ESP/ASR) warning light

This comes on for 3 seconds each time the ignition is switched on.

If the light remains on or comes on when the engine is running and the vehicle is moving, it is accompanied by an audible signal and the message **"ESP/ASR system not operational"** on the multi-function display; contact a PEUGEOT dealer.



Engine diagnostics warning light

This comes on each time the ignition is switched on.

If it comes on with the engine running, accompanied by an audible signal and the message on the multi-function display:

- **"Emission control system problem"**, it indicates a malfunction in the emission control system.
- **"Diesel additive low level"** or **"Risk of clogging of particulate emission filter"** indicates a malfunction in the particulate emission filter (due to exceptionally prolonged urban driving conditions: reduced speed, long traffic jams, ...). To regenerate the filter, you are advised to drive, as soon as possible when traffic conditions permit, at a speed of 35 mph (60 km/h) or above for at least five minutes (until the warning light goes out). If the warning light remains on, contact a PEUGEOT dealer.

If it flashes when the engine is running, accompanied by an audible signal and the message **"Catalytic converter faulty"** on the multi-function display, it indicates a malfunction in the injection or ignition system. There is a risk of damage to the catalytic converter (petrol engines only).

Contact a PEUGEOT dealer as soon as possible.



Diesel pre-heat light

This comes on each time the ignition is switched on

Wait until it goes out before trying the starter.



Water in diesel filter warning light (according to country)

Illumination of this warning light is accompanied by an audible signal and the message **"Water in diesel filter"** on the multi-function display.

There is a risk of damage to the injection system.

Contact a PEUGEOT dealer as soon as possible.

INSTRUMENTS AND CONTROLS



Passenger air bag disarmed indicator light

Illumination of this warning light is accompanied by an audible signal and the message "**Passenger air bag disarmed**" on the multi-function display.

If the passenger air bag is disarmed, the indicator light comes on when the ignition is switched on and remains on.

In all cases, if the warning light flashes; contact a PEUGEOT dealer.



Air bag warning light

This light comes on for a few seconds when the ignition is switched on.

Illumination of this warning light, with the engine running, is accompanied by an audible signal and the message "**Air bag fault**" on the multi-function display indicating :

- a fault in the front air bags,

or

- a fault in the side air bags or curtain air bags.

Contact a PEUGEOT dealer.



Seat belt not fastened warning light

With the engine running, this indicator light comes on when the driver's seat belt is not fastened.



Low fuel level warning light.

The warning light comes on for three seconds when the ignition is switched on.

When this light comes on with the engine running, it is accompanied by an audible signal and the message "**Fuel level low**" on the multi-function display.

When the warning light comes on, you have enough fuel to drive at least **30 miles (50 km)**. The tank capacity is approximately 60 litres.

This light flashes to indicate a malfunction of the fuel gauge.

Contact a PEUGEOT dealer.



Coolant temperature indicator

When the needle is in zone **A**, the temperature is correct.

When the needle is in zone **B**, the temperature is too high. The central **STOP** warning light flashes, accompanied by an audible signal and the message "**Coolant temp. high**" on the multi-function display.

You must stop immediately.

Warning: wait for the engine to cool before topping up the level.

The cooling system is pressurised.

In order to avoid any risk of scalding, unscrew the cap two turns to allow the pressure to drop.

When the pressure has dropped, remove the cap and top up the level.

Contact a PEUGEOT dealer.

INSTRUMENTS AND CONTROLS



Passenger air bag disarmed indicator light

Illumination of this warning light is accompanied by an audible signal and the message "**Passenger air bag disarmed**" on the multi-function display.

If the passenger air bag is disarmed, the indicator light comes on when the ignition is switched on and remains on.

In all cases, if the warning light flashes; contact a PEUGEOT dealer.



Air bag warning light

This light comes on for a few seconds when the ignition is switched on.

Illumination of this warning light, with the engine running, is accompanied by an audible signal and the message "**Air bag fault**" on the multi-function display indicating :

- a fault in the front air bags,

or

- a fault in the side air bags or curtain air bags.

Contact a PEUGEOT dealer.



Seat belt not fastened warning light

With the engine running, this indicator light comes on when the driver's seat belt is not fastened.



Low fuel level warning light.

The warning light comes on for three seconds when the ignition is switched on.

When this light comes on with the engine running, it is accompanied by an audible signal and the message "**Fuel level low**" on the multi-function display.

When the warning light comes on, you have enough fuel to drive at least **30 miles (50 km)**. The tank capacity is approximately 60 litres.

This light flashes to indicate a malfunction of the fuel gauge.

Contact a PEUGEOT dealer.



Coolant temperature indicator

When the needle is in zone **A**, the temperature is correct.

When the needle is in zone **B**, the temperature is too high. The central **STOP** warning light flashes, accompanied by an audible signal and the message "**Coolant temp. high**" on the multi-function display.

You must stop immediately.

Warning: wait for the engine to cool before topping up the level.

The cooling system is pressurised.

In order to avoid any risk of scalding, unscrew the cap two turns to allow the pressure to drop.

When the pressure has dropped, remove the cap and top up the level.

Contact a PEUGEOT dealer.

INSTRUMENTS AND CONTROLS

Selector lever positions on the automatic gearbox display



Park



Reverse



Neutral



Drive

Manual mode :



1st gear engaged



2nd gear engaged



3rd gear engaged



4th gear engaged

Automatic gearbox indicator lights



"SPORT" indicator light

This comes on when the "SPORT" programme on the automatic gearbox is selected.



"SNOW" indicator light

This comes on when the "SNOW" programme on the automatic gearbox is selected.

INSTRUMENTS AND CONTROLS

Instrument panel display

After switching on the ignition, three functions are shown in succession:

- service indicator (see corresponding section),
- engine oil level indicator,
- total distance recorder (total and trip distances).

Note: the total and trip distances are displayed for 30 seconds when the ignition is switched off, on opening the driver's door, as well as on locking and unlocking the vehicle.

Engine oil level indicator

When the ignition is switched on, the engine oil level is indicated for approximately 10 seconds, after the servicing information.



Surplus oil

Flashing indicates a surplus of oil which can cause damage to the engine.

If the surplus of oil is confirmed by checking using the dipstick, contact a PEUGEOT dealer without delay.



No oil

Flashing indicates a lack of oil which can cause damage to the engine.

If the lack of oil is confirmed by checking using the dipstick, it is essential to top up the level.



Oil level gauge fault

Check the oil level using the dipstick.

If the level is correct, the flashing indicates a true engine oil level gauge fault.

Contact a PEUGEOT dealer.

The value obtained by checking the level using the dipstick is only correct if the vehicle has been on level ground, with the engine off, for more than 10 minutes.



Lighting rheostat

With the lights on, press the button to vary the intensity of the lighting on the instrument panel and the multi-function display. When the lighting reaches the minimum (or maximum) setting, release the button then press it again to increase (or reduce) the brightness.

As soon as the lighting is of the required brightness, release the button.

As soon as the lighting is of the required brightness, release the button.



Trip recorder zero reset

With the ignition on, press the button.

YOUR 307 SW IN DETAIL

MULTI-FUNCTION SCREENS

Presentation



Monochrome screen B

This enables the following information to be displayed:

- the time,
- the date,
- the outside temperature (the °C symbol flashes when there is a risk of ice),
- the radio displays,
- the status of the openings (doors, bonnet ...),
- the warning messages (e.g. "Battery charge fault") or information messages (e.g. "Passenger air bag disarmed") displayed temporarily can be cleared by pressing button **1** or **2**,
- the trip computer (see corresponding section).

Monochrome screen CT and colour screen DT

These two systems are controlled by the **RT3 audio/telephone** keypad.

They enable the following information to be displayed:

- the time,
- the date,
- the outside temperature (a message warns you when there is a risk of ice),
- the audio source displays (radio, CD, ...),
- the telematic system displays (telephone, services, ...),
- the status of the openings (doors, bonnet, ...),
- the warning messages (e.g. "Fuel level low") and vehicle functions status messages (e.g. "Passenger air bag disarmed") displayed temporarily,
- the trip computer display (see corresponding section),
- the satellite navigation system displays (see corresponding section).

Note: to enable you to use all of your system's functions, you have two CD ROMs: one, "Configuration", contains the software and the various display and spoken information languages, the other, "Navigation", contains the satellite navigation system map data.



Monochrome screen CT

General menu



Press the "**MENU**" button to access the **general menu** and select one of the following applications:

- navigation - guidance (see section "Satellite navigation system"),
- trip computer (see corresponding section),
- audio/telephone" section),
- telematics (see "RT3 audio/telephone" section),
- configuration (see corresponding section).

YOUR 307 SW IN DETAIL



Colour screen DT

General menu



Press the **"MENU"** button to access the **general menu** and select one of the following applications:

- navigation - guidance (see section "Satellite navigation system"),
- trip computer (see corresponding section),
- directory (see "RT3 audio/telephone" section),
- telematics (see "RT3 audio/telephone" section),

- configuration (see corresponding section).
- map (see section "Satellite navigation system")

A few definitions

Superimposed display:

a window appears over the current application for a short while, to announce a change of status of another application.

Permanent application:

main application currently in use, displayed in the main screen window.

Contextual menu:

limited menu associated with the main application currently in use, displayed in the main screen window.

Parameter configuration



Monochrome screen B

Press button **1** for two seconds to gain access to the settings.

Then, each press of this button permits scrolling of the various parameters.

- language of the information displayed,
- unit of speed (km or miles),
- unit of temperature (degrees Celsius or Fahrenheit),
- time format (12 or 24 hours),
- hour,
- minute,
- year,
- month,
- day.

Pressing button **2** enables you to change the parameter selected. Continue pressing the button for rapid scrolling.

After ten seconds without action, the screen returns to the usual display, the modified data are recorded.

YOUR 307 SW IN DETAIL



Colour screen DT

General menu



Press the **"MENU"** button to access the **general menu** and select one of the following applications:

- navigation - guidance (see section "Satellite navigation system"),
- trip computer (see corresponding section),
- directory (see "RT3 audio/telephone" section),
- telematics (see "RT3 audio/telephone" section),

- configuration (see corresponding section).
- map (see section "Satellite navigation system")

A few definitions

Superimposed display:

a window appears over the current application for a short while, to announce a change of status of another application.

Permanent application:

main application currently in use, displayed in the main screen window.

Contextual menu:

limited menu associated with the main application currently in use, displayed in the main screen window.

Parameter configuration



Monochrome screen B

Press button **1** for two seconds to gain access to the settings.

Then, each press of this button permits scrolling of the various parameters.

- language of the information displayed,
- unit of speed (km or miles),
- unit of temperature (degrees Celsius or Fahrenheit),
- time format (12 or 24 hours),
- hour,
- minute,
- year,
- month,
- day.

Pressing button **2** enables you to change the parameter selected. Continue pressing the button for rapid scrolling.

After ten seconds without action, the screen returns to the usual display, the modified data are recorded.

YOUR 307 SW IN DETAIL

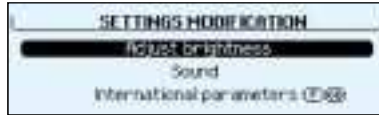

CT monochrome screen

The **"Configuration"** menu gives access to the following parameters:

- "Adjust the brightness": display brightness setting.
- "Sound": voice synthesiser setting (for the masculine/feminine voice parameter: insert the configuration CD-Rom); setting of the spoken commands,
- "International parameters": choice of the language of the display, information and spoken commands (German, English, Spanish, French, Italian, Dutch, Portuguese: insert the configuration CD-Rom); date and time setting (12 or 24 hour mode, adjustment of the minutes on GPS); units setting (l/100 - °C or mpg - °F).



DT colour screen

The **"Configuration"** menu gives access to the following parameters:

- "Choose colours": selection from the palette of colours available for display,
- "Adjust the brightness": display brightness setting.
- "Sound": voice synthesiser setting (for the masculine/feminine voice parameter: insert the configuration CD-Rom); setting of the spoken commands,
- "International parameters": choice of the language of the display, information and spoken commands (German, English, Spanish, French, Italian, Dutch, Portuguese: insert the configuration CD-Rom); date and time setting (12 or 24 hour mode, adjustment of the minutes on GPS); units setting (l/100 - °C or mpg - °F).



For safety reasons, configuration of the multi-function screens by the driver must be carried out when stationary.

YOUR 307 SW IN DETAIL

AUDIO RB3

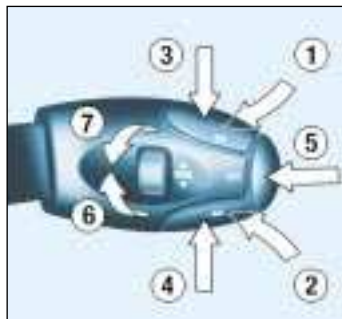

Stalk movement	Function
1 - Press (behind)	Increase volume.
2 - Press (behind)	Decrease volume.
1 + 2 - Simultaneous press	Sound cut-off (mute); restoring of the sound by pressing any button.
3 - Press	Automatic search of higher frequencies (radio) - Selection of the next track (CD).
4 - Press	Automatic search of lower frequencies (radio) - Selection of the previous track (CD).
5 - Press the end	Change of source (radio/cassette/CD changer).
6 - Rotation (clockwise)	Selection of next station stored in the memory (radio) - Selection of next CD.
7 - Rotation (anti-clockwise)	Selection of previous station stored in the memory (radio) - Selection of previous CD.

YOUR 307 SW IN DETAIL

Button		Function
A		Radio on/off.
B	—	Decrease volume.
C	+	Increase volume.
D	RDS	RDS function on / off. Press for more than 2 seconds : regional following mode on/off.
E	TA	Traffic information priority on/off.
F		Press fully: cassette rewind.
G		Press fully: fast forward.
F + G	◀ ▶ ◀▶ ▶▶	Press half way: reversal of direction of play of the cassette. Press fully: ejection of the cassette.
H	♪	Selection of bass, treble, loudness, sound distribution and automatic volume correction.
I	▲	Increase setting of functions associated with button H .
J	▼	Decrease setting of functions associated with button H .
K	SRC	Selection of source: radio, cassette or CD changer. Press for more than 2 seconds: CD shuffle.
L	▶▶	Manual and automatic search of higher frequency. Selection of next CD track and PTY (radio).
M	MAN	Manual/automatic operation of buttons L and N in radio mode.
N	◀◀	Manual and automatic search of lower frequency. Selection of previous CD track and PTY (radio).
O	BND AST	Selection of FM1, FM2, FMast and AM wavebands. Press for more than 2 seconds: automatic storing of stations in the memory (autostore).
1 to 6	1 2 3 4 5 6	Selection of station stored in the memory. Press for more than 2 seconds: storing of a station in the memory.
1 to 5	1 2 3 4 5	Selection of a CD changer disc.

YOUR 307 SW IN DETAIL

GENERAL FUNCTIONS



On/off

With the ignition key in the accessories or ignition position, press button **A** to switch the set on or off.
The set can operate for 30 minutes without the vehicle ignition being switched on.

Anti-theft system

The audio system is coded in such a way that it can operate only on your vehicle. It would not function if fitted to another vehicle.

The anti-theft system is automatic and requires no action on your part.

ADJUSTING THE VOLUME

Press button **C** to increase the volume, or button **B** to decrease it.

Continuous pressure on buttons **C** and **B** allows a gradual adjustment of the volume.

AUDIO SETTINGS



Press button **H** several times in succession to access the bass (**BASS**), treble (**TREB**), loudness (**LOUD**), fader (**FAD**), balance (**BAL**) and automatic volume correction settings.

Exit from audio mode is automatic after a few seconds without pressing any button, or by pressing button **H** after configuration of the automatic volume correction.

Note : bass and treble settings are specific to each source. It is possible to set them differently for radio, cassette (**RB3**), CD (**RD3**) and CD changer.

YOUR 307 SW IN DETAIL

Adjusting the bass



When "**BASS**" is displayed, press button **I** or **J** to vary the setting.

- "**BASS -9**" for a minimum bass setting,
- "**BASS 0**" for a normal setting,
- "**BASS +9**" for a maximum bass setting.

Adjusting the treble

When "**TREB**" is displayed, press button **I** or **J** to vary the setting.

- "**TREB -9**" for a minimum treble setting,
- "**TREB 0**" for a normal setting,
- "**TREB +9**" for a maximum treble setting.

Adjusting the loudness

This function automatically emphasises bass and treble tones.

Press button **I** or **J** to switch the function on or off.

Adjusting the front/rear sound distribution (Fader)

When "**FAD**" is displayed, press button **I** or **J**.

Button **I** increases the volume in the front.

Button **J** increases the volume in the rear.

Adjusting the right/left sound distribution (Balance)

When "**BAL**" is displayed, press button **I** or **J**.

Button **I** increases the volume on the right-hand side.

Button **J** increases the volume on the left-hand side.

Automatic volume correction

This function enables the volume to be automatically adjusted depending on the level of noise produced by the speed of the vehicle.

Press buttons **I** or **J** to switch the function on or off.

YOUR 307 SW IN DETAIL

RADIO

Notes on radio reception

Your car radio is subject to phenomena which do not affect domestic radio sets. Both AM (MW/LW) and FM reception are subject to various forms of interference. This is no reflection on the quality of the equipment, but is due to the nature of the signals and the way in which they are transmitted.

On MW/LW, interference may be noticed when passing under high voltage power lines or bridges, or in tunnels.

On FM, interference may be the result of increasing distance from the transmitter, deflection of the signals by obstacles (mountains, hills, buildings, etc.), or of being in an area which is not covered by a transmitter.

Selecting radio mode

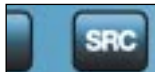

Audio RB3 : press the "SRC" button several times in succession.



Audio RD3 : press button R.

Selecting a waveband



Audio RB3 : briefly press the "BND/AST" button to select the FM1, FM2, FMast and AM wavebands.



Audio RD3 : briefly press button R to select the FM1, FM2, FMast and AM wavebands.

Automatic station search



Briefly press button **L** or **N** to search for the station immediately above or below. By continuing to press the button in the direction selected, you will obtain continuous scrolling of the frequency.

The scrolling stops at the first station found as soon as the button is released.

If the **TA** traffic programme is selected, only stations broadcasting this type of programme are selected.

Searching for a station occurs first in "**LO**" sensitivity (selection of the most powerful transmitters) during scanning of the waveband, then in "**DX**" sensitivity (selection of the weakest and most distant transmitters).

To make a direct search in "**DX**" sensitivity, press button **L** or **N** twice.

YOUR 307 SW IN DETAIL

Manual station search

Press the "**MAN**" button.

Briefly press button **L** or **N** to increase or decrease the frequency displayed.

By continuing to press the button in the direction selected, you will obtain continuous scrolling of the frequency.

The scrolling stops as soon as the button is released.

Pressing the "**MAN**" button again returns you to automatic station search.

Manual storing of stations in the memory

Select the station required.

Press one of the buttons "**1**" to "**6**" for more than two seconds.

The sound stops then becomes audible again, confirming that the station has been stored in the memory.

Automatic storing of FM stations in the memory (autostore)



*Audio RB3 : press and hold the "**BND/AST**" button for more than two seconds.*



*Audio RD3 : press and hold button **R** for more than two seconds.*

Your radio automatically stores the 6 stations with the strongest signal in **FM**. These stations are stored in the FMast waveband.

If it is not possible to find 6 stations, the remaining memories are empty.

Recalling stations stored in the memory

For each waveband, briefly press buttons "**1**" to "**6**" to recall the corresponding station.

YOUR 307 SW IN DETAIL

RDS

Using the RDS (Radio Data System) function on FM

Radio Data System allows you to continue listening to the same station, whatever frequency it is using for the region you are going through.



Briefly press the "RDS" button to switch the function on or off.

The multi-function display will show:

- "RDS" if the function is selected.
- "(RDS)" if the function is selected but not available.

RDS station following

The display indicates the name of the station selected. The radio is continually searching for the station which has the best reception and which is transmitting the same programme.

Traffic information programme



Press the "TA" button to switch the function on or off.

The multi-function display will show:

- "TA" if the function is selected,
- "(TA)" if the function is selected but not available.

Any traffic information flash will be given priority, whatever source you are listening to (radio, cassette or CD changer).

If you wish to interrupt a message, press the "TA" button; this switches the function off.

Note : the volume of traffic information announcements is independent of the volume of normal radio listening. You can adjust it using the volume button. The setting will be stored and will be used when the next messages are broadcast.

Regional following mode

When they are part of a network (REG), certain stations broadcast regional programmes in the various areas they serve. With regional following mode you can keep listening to the same programme.

Press the "RDS" button for more than two seconds to switch the function on or off.

YOUR 307 SW IN DETAIL

CASSETTE: AUDIO RB3

Selecting cassette mode

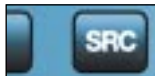

When a cassette is inserted, the cassette player will start automatically.

If a cassette is already inserted, press the "**SRC**" button until cassette mode is selected.

Note: before inserting the cassette, ensure that the tape is taut.

Ejecting the cassette



Fully press buttons **F** and **G** to eject the cassette from the player.

Direction of play

The player will play sides 1 and 2 of the cassette alternately, by automatically reversing the direction of play at the end of a side.

To manually reverse the direction of play, press buttons **F** and **G** half-way.

Fast forward/rewind

Fully press button **F** or **G** to fast forward or rewind the cassette. At the end of the fast forward/rewind, the set plays the current side.

Recommendations for using cassettes

- Use good quality cassettes.
- Avoid the use of cassettes which play for longer than 90 minutes.
- Never expose the cassettes to heat or the direct rays of the sun.
- Re-tighten the tape if necessary before inserting the cassette into the player.
- Clean the playing head regularly with a damp-type cleaning cassette.

YOUR 307 SW IN DETAIL

CD CHANGER

Selecting CD changer mode



Audio RB3 : press the "SRC" button several times in succession.



Audio RD3 : press button P.

Selecting a disc

Press buttons "1" to "5" on the radio to select the corresponding disc.

Selecting a track



Press button **L** to select the next track.

Press button **N** to return to the start of the current track or to select the previous track.

Accelerated play

Press and hold button **L** or **N** for forwards or backwards accelerated play.

Accelerated play stops as soon as the button is released.

Shuffle (RDM)

When the CD changer is selected:

- *audio RB3 : press and hold the "SRC" button for two seconds;*

- *audio RD3 : press and hold button P for two seconds.*

The tracks will be played in random sequence. Pressing the button again for two seconds returns you to normal play.

YOUR 307 SW IN DETAIL

AUDIO RD3

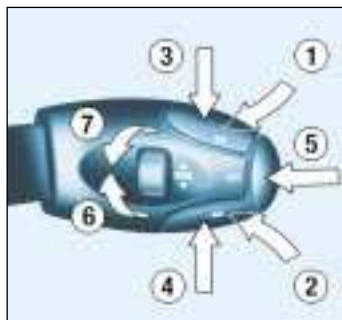

Stalk movement	Function
1 - Press (behind)	Increase volume.
2 - Press (behind)	Decrease volume.
1 + 2 - Simultaneous press	Sound cut-off (mute); restoring of the sound by pressing any button.
3 - Press	Automatic search of higher frequencies (radio) - Selection of the next track (CD).
4 - Press	Automatic search of lower frequencies (radio) - Selection of the previous track (CD).
5 - Press the end	Change of source (radio/cassette/CD changer).
6 - Rotation (clockwise)	Selection of next station stored in the memory (radio) - Selection of following CD.
7 - Rotation (anti-clockwise)	Selection of previous station stored in the memory (radio) - Selection of previous CD.

YOUR 307 SW IN DETAIL

Button		Function
A		Radio on/off.
B	—	Decrease volume.
C	+	Increase volume.
D	RDS	RDS function on / off. Press for more than 2 seconds : regional following mode on/off.
E	TA	Traffic information priority on/off. Press for more than 2 seconds: PTY function on/off.
H		Selection of bass, treble, loudness, sound distribution and automatic volume correction.
I	▲	Increase setting of functions associated with button H .
J	▼	Decrease setting of functions associated with button H .
L	▶▶	Manual and automatic search of higher frequency. Selection of next CD track and PTY (radio).
M	MAN	Manual/automatic operation of buttons L and N .
N	◀◀	Manual and automatic search of lower frequency. Selection of previous CD track and PTY (radio).
P	CH.CD	Selection of the CD changer. Press for more than 2 seconds: shuffle.
Q	CD	Selection of the CD. Press for more than 2 seconds: shuffle.
R	Radio	Selection of the radio. Selection of FM1, FM2, FMast, AM wavebands. Press for more than 2 seconds: automatic storing of stations in the memory (autostore).
S	▲	Ejection of the CD.
1 to 6	1 2 3 4 5 6	Selection of station stored in the memory. Press for more than 2 seconds: storing of a station in the memory.
1 to 5	1 2 3 4 5	Selection of a CD changer disc.

YOUR 307 SW IN DETAIL

RADIO

Notes on radio reception

Your car radio is subject to phenomena which do not affect domestic radio sets. Both AM (MW/LW) and FM reception are subject to various forms of interference. This is no reflection on the quality of the equipment, but is due to the nature of the signals and the way in which they are transmitted.

On MW/LW, interference may be noticed when passing under high voltage power lines or bridges, or in tunnels.

On FM, interference may be the result of increasing distance from the transmitter, deflection of the signals by obstacles (mountains, hills, buildings, etc.), or of being in an area which is not covered by a transmitter.

Selecting radio mode



Audio RB3 : press the "SRC" button several times in succession.



Audio RD3 : press button R.

Selecting a waveband



Audio RB3 : briefly press the "BND/AST" button to select the FM1, FM2, FMast and AM wavebands.



Audio RD3 : briefly press button R to select the FM1, FM2, FMast and AM wavebands.

Automatic station search



Briefly press button **L** or **N** to search for the station immediately above or below. By continuing to press the button in the direction selected, you will obtain continuous scrolling of the frequency.

The scrolling stops at the first station found as soon as the button is released.

If the **TA** traffic programme is selected, only stations broadcasting this type of programme are selected.

Searching for a station occurs first in "**LO**" sensitivity (selection of the most powerful transmitters) during scanning of the waveband, then in "**DX**" sensitivity (selection of the weakest and most distant transmitters).

To make a direct search in "**DX**" sensitivity, press button **L** or **N** twice.

YOUR 307 SW IN DETAIL

Manual station search

Press the "**MAN**" button.

Briefly press button **L** or **N** to increase or decrease the frequency displayed.

By continuing to press the button in the direction selected, you will obtain continuous scrolling of the frequency.

The scrolling stops as soon as the button is released.

Pressing the "**MAN**" button again returns you to automatic station search.

Manual storing of stations in the memory

Select the station required.

Press one of the buttons "**1**" to "**6**" for more than two seconds.

The sound stops then becomes audible again, confirming that the station has been stored in the memory.

Automatic storing of FM stations in the memory (autostore)



*Audio RB3 : press and hold the "**BND/AST**" button for more than two seconds.*



*Audio RD3 : press and hold button **R** for more than two seconds.*

Your radio automatically stores the 6 stations with the strongest signal in **FM**. These stations are stored in the FMast waveband.

If it is not possible to find 6 stations, the remaining memories are empty.

Recalling stations stored in the memory

For each waveband, briefly press buttons "**1**" to "**6**" to recall the corresponding station.

YOUR 307 SW IN DETAIL

RDS

Using the RDS (Radio Data System) function on FM

Radio Data System allows you to continue listening to the same station, whatever frequency it is using for the region you are going through.



Briefly press the "RDS" button to switch the function on or off.

The multi-function display will show:

- "RDS" if the function is selected.
- "(RDS)" if the function is selected but not available.

RDS station following

The display indicates the name of the station selected. The radio is continually searching for the station which has the best reception and which is transmitting the same programme.

Traffic information programme



Press the "TA" button to switch the function on or off.

The multi-function display will show:

- "TA" if the function is selected,
- "(TA)" if the function is selected but not available.

Any traffic information flash will be given priority, whatever source you are listening to (radio, cassette or CD changer).

If you wish to interrupt a message, press the "TA" button; this switches the function off.

Note : the volume of traffic information announcements is independent of the volume of normal radio listening. You can adjust it using the volume button. The setting will be stored and will be used when the next messages are broadcast.

Regional following mode

When they are part of a network (REG), certain stations broadcast regional programmes in the various areas they serve. With regional following mode you can keep listening to the same programme.

Press the "RDS" button for more than two seconds to switch the function on or off.

YOUR 307 SW IN DETAIL

PTY function: Audio RD3

This allows you to listen to stations broadcasting a specific type of programme (news, culture, sport, rock etc.).



With FM selected, press the "TA" button for two seconds to switch this function on or off.



To search for a **PTY** programme:

- select the **PTY** function,
- briefly press button **L** or **N** to scroll down the list of the various types of programmes offered.
- when the programme of your choice is displayed, keep button **L** or **N** pressed for two seconds to carry out an automatic search (after an automatic search the **PTY** function is switched off).

In **PTY** mode the different types of programmes can be stored in the memory. To do this, press the preselection buttons "**1**" to "**6**" for two seconds.

Briefly press the corresponding button to recall the type of programme stored in the memory.

EON system: Audio RD3

This connects stations which are part of the same network. It enables the broadcast of traffic information or a **PTY** programme, by a station that is part of the same network as the station to which you are listening.

This service is available when you have selected the **TA** traffic information programme or the **PTY** function.

YOUR 307 SW IN DETAIL

COMPACT DISC : AUDIO RD3

Selecting CD mode



After insertion of a disc, printed face upwards, the player starts automatically.
If a disc is already inserted, press button **Q**.

Ejection of a disc



Press button **S** to eject the disc from the player.

Selecting a track



Press button **L** to select the next track.

Press button **N** to return to the start of the current track or to select the previous track.

Accelerated play

Press and hold button **L** or **N** for forwards or backwards accelerated play.
Accelerated play stops as soon as the button is released.

Shuffle (RDM)

When the CD player is selected, press and hold button **Q** for two seconds. The tracks will be played in random sequence.
Pressing the button again for two seconds returns you to normal play.
Shuffle mode is de-activated each time the set is switched off.



*The use of copied compact discs may cause faults.
Insert circular compact discs only.*

YOUR 307 SW IN DETAIL

AUDIO/TELEPHONE RT3

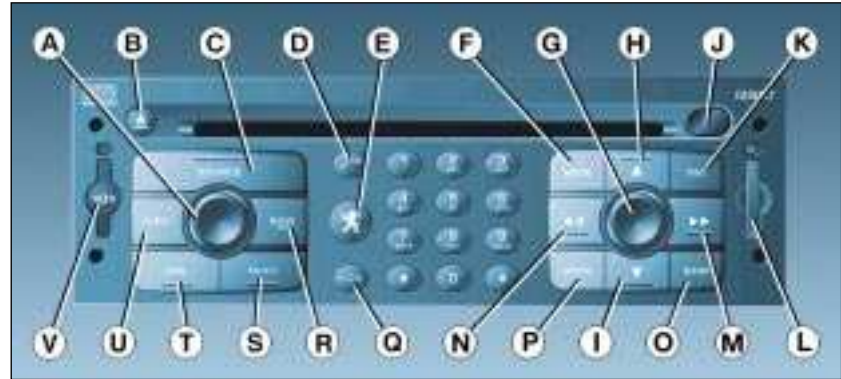
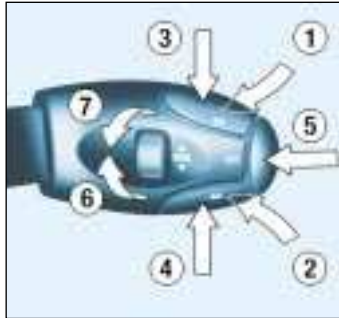

Stalk movement	Function
1 - Press (behind)	Increase volume
2 - Press (behind)	Decrease volume
1 + 2 - Press together	Switch off sound (mute); restore sound by pressing any button
3 - Press	Automatic search of upper frequencies (radio) - Selection of next track (CD/CD changer) Continuous pressure until release: fast forwards (CD/CD changer)
4 - Press	Automatic search of lower frequencies (radio) - Selection of previous track (CD/CD changer) Continuous pressure until release: rewind (CD/CD changer)
5 - Press end	Change source (radio/CD/CD changer) - Confirmation of selection (on a menu or screen) - Call connect/Call disconnect (Tel./incoming call) - Call disconnect (Tel./Engaged) Press for more than 2 seconds: display contextual menu (Tel./Not engaged)
6 - Rotation (clockwise)	Selection of higher station stored in memory or storing in memory in position 1 for station not in memory (radio) - Selection of following CD - Selection of following item (on a menu or screen)
7 - Rotation (anti-clockwise)	Selection of lower station stored in memory or storing in memory in position 6 for station not in memory (radio) - Selection of previous CD - Selection of previous item (on a menu or screen)

YOUR 307 SW IN DETAIL

Stalk movement		Function
A		Press: audio/telephone on/off. Rotation: volume adjustment - Audio settings: bass, treble, loudness, fader (front/rear balance), balance (left/right balance), automatic volume.
B	▲	Ejection of CD.
C	SOURCE	Selection of source : radio, CD or CD changer.
D		Call connect (Tel/Incoming call) - Display contextual menu (Tel/Not engaged).
E		Access "PEUGEOT" services menu. Press for between 2 and 8 seconds : call " PEUGEOT Assistance" direct. Press for more than 8 seconds: cancellation of the call made.
F	MODE	Change display Press for more than 2 seconds : display general information.
G		Press : display contextual menu of display - Confirm inputting or adjustment. Rotation : move within a menu - Select function / parameter - Adjust.
H	▲	Adjust higher frequency, step by step or continuous (long press). Select previous CD (CD changer) - Movement on map (navigation).
I	▼	Adjust lower frequency, step by step or continuous (long press). Select following CD (CD changer) - Movement on map (navigation).
J		Infra-red window (IrDA)*.
K	ESC	Cancel current operation. Press for more than 2 seconds : clear all superimposed displays and return to permanent application.
L		SIM card cover.
M	▶▶	Automatic search of higher frequency - Selection of following CD track. Movement on map (navigation). Double press : change from LO mode to DX mode. Press for more than 2 seconds : CD fast forward.

YOUR 307 SW IN DETAIL

Stalk movement		Function
N	◀◀	Automatic search of lower frequency - Selection of previous CD track. Movement on map (navigation). Double press : change from LO mode to DX mode. Press for more than 2 seconds : CD rewind.
O	DARK	1st press : display top band (remainder of screen is black) - 2nd press: brightness removed (black screen) - 3rd press: return to normal screen. Press for more than 5 seconds: reinitialisation of the system.
P	MENU	Display general menu - Press for more than 2 seconds : display help screen and list of voice commands.
Q		Disconnect. Press for more than 2 seconds: transfer of the call to the voice mail or to a call diversion number.
R	BAND AST	Select FM1, FM2, FMast, AM wavebands. Press for more than 2 seconds : automatic storing of stations (autostore).
S	TA/PTY	Traffic information priority on/off Press for more than 2 seconds: PTY function on/off.
T	RDS	RDS function on/off. Press for more than 2 seconds : regional following mode on/off
U	AUDIO	Display window for adjusting bass, treble, loudness, sound distribution and automatic correction of volume.
V	SOS	Press between 2 and 8 seconds : emergency call. Press for more than 8 seconds: cancellation of the call made.
1 to 6	1 2 3 4 5 6	Select station in memory. Press more than 2 seconds : store station in memory while listening.
1 to 5	1 2 3 4 5	Selection of CDs in the CD changer.
0 to 9 * #	0 1 2 3 4 5 6 7 8 9 * #	Alphanumeric keypad for entering text and telephone numbers.

* During the year.

YOUR 307 SW IN DETAIL

GENERAL FUNCTIONS



On/off

With the ignition switch in the accessories position or with the ignition on, press button **A** to switch the audio function of the RT3 audio/telephone on or off.

Note: in the absence of an ignition key, press button **A** to switch the telematics system on or off.

The RT3 audio/telephone can operate for 30 minutes without switching the vehicle ignition on.

Notes:

- the SIM card must be removed only after the audio/telephone has been switched off,
- following automatic switching off of the audio/telephone after 30 minutes it is possible to make a telephone call by pressing button **D**,
- after the ignition has been switched off, the audio/telephone can be switched on again by pressing buttons **D**, **E**, **V** or by inserting a CD in the player.

Anti-theft system

The RT3 audio/telephone is coded in such a way that it can operate only on your vehicle. If fitting it to another vehicle, consult your PEUGEOT dealer for configuration of the system.

The anti-theft system is automatic and requires no action on your part.

ADJUSTING THE VOLUME

Turn button **A** clockwise to increase the volume of the audio/telephone or anti-clockwise to decrease it.

Note: the volume setting is specific to each source. It is possible to have different settings for radio, CD or CD changer.

AUDIO SETTINGS



Press button **U** to access **Bass**, **Treble**, **Loudness**, **Fader** (front/rear balance), **Balance** (left/right balance) and **Automatic volume adjustment** settings.

Exit from audio mode is automatic after a few seconds without any action, or by pressing the "**ESC**" button.

Note: bass, treble and loudness settings are specific to each source. It is possible to have different settings for radio, CD or CD changer.

YOUR 307 SW IN DETAIL

Bass setting



When "**Bass**" is displayed, turn button **A** to vary the setting.

- "**-9**" for minimum bass setting
- "**0**" for normal setting
- "**+9**" for maximum bass setting

Treble setting

When "**Treble**" is displayed, turn button **A** to vary the setting.

- "**-9**" for minimum treble setting
- "**0**" for normal setting
- "**+9**" for maximum treble setting

Adjusting the loudness

This function automatically emphasises bass and treble tones when the volume is low.

Rotate button **A** to switch the function on or off.

Setting the front/rear sound distribution (Fader)

When "**Fader**" is displayed:

- Turn button **A** clockwise to increase the volume in the front.
- Turn button **A** anti-clockwise to increase the volume in the rear.

Setting the right/left sound distribution (Balance)

When "**Balance**" is displayed:

- Turn button **A** clockwise to increase the volume on the right.
- Turn button **A** anti-clockwise to increase the volume on the left.

Automatic volume adjustment "CAV"

This function allows the volume to be adjusted automatically depending on the level of noise produced by the speed of the vehicle.

Press button **A** to switch the function on or off.

YOUR 307 SW IN DETAIL

RADIO

Notes on radio reception

Car radio/telephone receivers are subject to phenomena which do not affect domestic radio sets. Both MW/LW and FM are subject to various forms of interference. This is not a reflection on the quality of the equipment, but is due to the nature of the signals and the way in which they are transmitted.

On MW/LW interference may be noticed when passing under high voltage power lines or bridges, or in tunnels.

On FM, interference may be the result of the increasing distance from the transmitter, deflection of the signals by obstacles (mountains, hills, buildings etc.) or of being in an area which is not covered by a transmitter.

Selecting the radio



Press "**SOURCE**" several times.

Selecting a waveband



Briefly pressing button "**BAND/AST**" to select the FM1, FM2 , FMast and AM wavebands.

Automatic station search



Briefly press button **M** or **N** to search for the station immediately above or below.

The search stops at the first station found.

If the **TA** traffic programme is selected, only the most powerful stations broadcasting this type of programme are selected.

Searching for a station occurs first in "**LO**" sensitivity (selection of the most powerful transmitters) for scanning of the waveband, then in "**DX**" sensitivity (selection of the weaker and more distant transmitters).

To make a direct search in "**DX**" sensitivity, briefly press button **M** or **N** twice.

YOUR 307 SW IN DETAIL

Manual station search



Briefly press button **H** or **I** to increase or decrease the frequency displayed.

By continuing to press the button in the direction selected, you will obtain continuous scrolling of the frequency. Scrolling stops at the first station found as soon as the button is released.

Manual station storing

Select the station required.

Press one of the buttons "**1**" to "**6**" for more than two seconds.

An audible signal is emitted, confirming that the station has been stored in the memory.

Automatic storing of FM stations in the memory



Press the "**BAND/AST**" button for more than two seconds.

Your audio/telephone automatically stores the 6 stations with the strongest signal in FM. These stations are stored in the FMast waveband.

If it is not possible to find 6 stations, the remaining memories are empty.

Recalling stations stored in the memory

For each waveband, briefly press the buttons "**1**" to "**6**" to recall the corresponding stored station.

YOUR 307 SW IN DETAIL

RDS SYSTEM

Using the RDS (Radio Data System) function on FM

Radio Data System allows you to continue listening to the same station, whatever frequency it is using for the region you are going through.



Briefly press the "RDS" button to switch the function on or off.

The multi-function screen will show:

- **RDS** if the function is active
- **RDS crossed out or greyed out** if the function is active but not available.

RDS station following

This display indicates the name of the station selected. The audio/telephone is continuously searching for the station which has the best reception and which is transmitting the same programme. This search may cause slight interference with the transmission.

Traffic information programme



Press the "TA/PTY" button to switch the function on or off.

The multi-function screen will show:

- **TA** if the function is selected
- **TA crossed out or greyed out** if the function is selected but not available.

Any traffic information flash will be given priority, whatever source you are listening to (radio, CD or CD changer).

If you wish to interrupt the broadcasting of a message, press the "TA/PTY" button.

Note: the volume of the traffic information is independent of the volume of normal radio/telephone listening. You can adjust it by using the volume button. The setting will be stored and will be used when the next messages are broadcast.

Regional following mode (REG)

When they are part of a network, certain stations broadcast regional programmes in the various areas they serve. With regional following mode you can keep listening to the same programme.

To do this, press the "RDS" button for more than two seconds to switch the function on or off.

The multi-function screen will show:

- **REG** if the function is active,
- **REG crossed out or greyed out** if the function is active but not available.

YOUR 307 SW IN DETAIL

PTY function

This allows you to listen to stations broadcasting a specific type of programme (news, culture, sport, rock etc.)

When FM is selected, press button "**TA/PTY**" for more than two seconds to switch the function on or off.

To find a **PTY** programme:



- select the **PTY** button,
- turn button **G** to scroll down the different types of programmes offered, then confirm your choice,
- when the programme of your choice is displayed press button **M** or **N** to carry out an automatic search (after an automatic search the **PTY** function is switched off if no station has been found).

In **PTY** mode the different types of programmes can be stored in the memory. To do this, press the preselection buttons "**1**" to "**6**" for more than two seconds. To recall the type of programme stored in the memory, briefly press the corresponding button.

EON system

This system connects stations which are part of the same network. It enables the broadcast of traffic information or a **PTY** programme, by a station that is part of the same network as the station to which you are listening.

The service is available when you have selected the **TA** traffic information programme or the **PTY** function.

Contextual menu

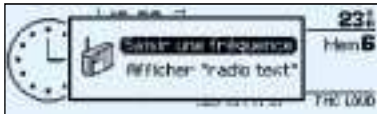

The contextual menu allows you to access the following functions:

- "Inputting a frequency"
- "Display Radio text" to display information connected with the station being listened to.

YOUR 307 SW IN DETAIL

COMPACT DISC

Selecting CD mode



After inserting a disc, printed face upwards, the CD drive starts automatically.
If a disc has already been inserted, press the "**SOURCE**" button to select CD mode.

Ejecting a disc



Press button **B** to eject the disc from the drive.

Selecting a track



Press button **M** to select the following track.
Press button **N** to return to the start of the current track or to select the previous track.

Accelerated play

Press and hold button **M** or **N** for forwards or backwards accelerated play.
Accelerated play stops as soon as the button is released.

Contextual menu



The contextual menu permits you to switch on or switch off the shuffle, track repeat, track programme or play the start of a track functions.



*Do not use copied CDs as these could damage your player.
Insert circular compact discs only.*

YOUR 307 SW IN DETAIL

COMPACT DISC CHANGER

Selecting CD changer mode



Press the "**SOURCE**" button several times.

Selecting a disc

Press one of the buttons "**1**" to "**5**" on the audio/telephone to select the appropriate disc.
Buttons **H** and **I** allow you to select respectively the previous or following disc in the changer.

Selecting a track



Press button **M** to select the following track.
Press button **N** to return to the start of the current track or to select the previous track.

Accelerated play

Press and hold button **M** or **N** for forwards or backwards accelerated play.
Accelerated play stops as soon as the button is released.

Contextual menu

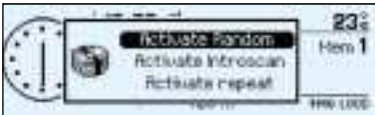

The contextual menu permits you to switch on or switch off the shuffle, playing the start of a track or repeat a track functions.

YOUR 307 SW IN DETAIL

TELEPHONE

This function is a GSM dual-band telephone (900 and 1 800 MHz) incorporated in the RT3 audio system.

It is a **"hands free"** telephone. This function is provided by a microphone located next to the front courtesy light, the speakers and a steering column control which allows access to most of the functions (the audio/telephone control panel buttons allow access to all the functions).

Display of the principal **"mobile"** type functions, as well as consultation of the indexes, is provided by the multi-function display.

This function is active, whatever position the ignition key is in even after thirty minutes, when the message **"Economy mode active"** appears on the multi-function display.

Using the menus

Press the **"MENU"** button to display the general menu. Select the **telematics** application, validate **"Telephone functions"** to access the principal telephone functions, then the various menus, in order to reach the one required.

This menu allows you to access the following functions:



- **Network:** allows you to select the network search mode and to see the networks available.
- **Duration of calls:** allows you to consult the duration recorder of calls made and zero re-set.
- **Security:** allows you to use or modify the PIN code and to erase the list of calls and mini-messages (SMS).
- **Telephone options:** allows you to configure the calls with entering of my number, automatic answering after X rings, specification of ring options and allows you to configure the call diversion number.

Within each menu:



Move around and select a function by turning the **G** button then validate by pressing the button. Cancel an operation using the **"ESC"** button.

YOUR 307 SW IN DETAIL

Using the alphanumeric keypad

For a given button, to input a character in the second or subsequent rows press until you obtain the character required.

Buttons	Associated characters
[1]	1 or space
[2]	2 or A B C 2 or a b c 2
[3]	3 or D E F 3 or d e f 3
[4]	4 or G H I 4 or g h i 4
[5]	5 or J K L 5 or j k l 5
[6]	6 or M N O 6 or m n o 6
[7]	7 or P Q R S 7 or p q r s 7
[8]	8 or T U V 8 or t u v 8
[9]	9 or W X Y Z 9 or w x y z 9
[0]	0 or + (long press)
[#]	# or P (long press)
[*]	* or erasing of last character input (long press)

Installing the SIM card



Open flap **L** by pressing the point of a pencil on the circular opening above the flap.

Insert your Micro-SIM card as indicated in the graphics, then close the flap.

Note: removal or insertion of the SIM card must only be carried out after the RT3 audio/telephone has been switched off.

Handle the SIM card with care to avoid losing it in the fascia.

YOUR 307 SW IN DETAIL

Inputting the PIN code



Input your PIN code using the alphanumeric keypad and validate by pressing button **G** or button **#** to access the network. Connection to the network is validated by the appearance of a symbol on the screen.

Warning: if you make three errors in succession when inputting your PIN code, your SIM card will be blocked. To unblock it, you will need to input the PUK code. The PUK code will be supplied to you by the person selling your SIM card (input of the PUK code allows for 10 errors in succession; after this the SIM card becomes permanently unusable).

Note: the PIN code is required each time the ignition is switched on, unless the PIN code has been stored in the memory or protection by PIN code is not activated on the SIM card.

Cancelling of PIN code request

In the menu "**Telephone functions**" select "**Security**", then "**Process the PIN code**", then validate the "**Cancel**" function.

Warning: in this case, do not lose your SIM card. Losing it would mean anyone who finds it would be able to make unlimited calls.

Telephone function screens

Not in use



This screen indicates the presence of voice messages or mini-messages (SMS) not listened to, the cumulative time in use since the last zero reset and the status of your telephone.

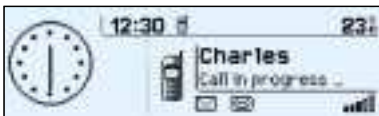

In use

This screen indicates the time elapsed since the start of the conversation, as well as the number* or name of the person to whom you are speaking (if recorded in the index) and the status of your telephone.

* If this option and service are available.

YOUR 307 SW IN DETAIL

Making a call

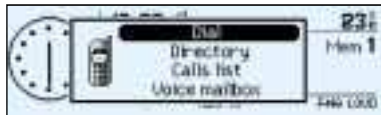

Press button **D** to display the contextual menu of the telephone.

Note: pressing the end 5 of the steering column control for more than 2 seconds calls up a contextual menu limited to the "**Directory**", "**List of calls**" and "**Voice mail**" functions.

Entering a number



Select the function "**Enter number**" then enter the number of the person you wish to speak to using the alphanumeric keypad.

Press button **D** to make the call.

Making a call from a directory

Select the "**Directory**" function to access all the files containing a telephone number or the "**List of calls**" function to access the list of the last ten incoming (if the number display option is active) or outgoing calls.

Note: there are two directories, the RT3 audio/telephone directory and the SIM card directory. To consult the SIM directory, insert your SIM card and enter your PIN code.

Receiving a call



When a ringing sounds to let you know that a call is waiting, you can choose either to accept it by pressing button **D** or the end of the steering wheel remote control or not to accept it by pressing the button **Q** or by selecting and validating the "**NO**" button on the "**Answer?**" screen.

If you accept the call, to end your communication, press button **Q**.

If you do not accept the call, it is transferred to your voice mail or to a call diversion number.

YOUR 307 SW IN DETAIL

Mini messages (SMS)

Accessing mini messages



When the buzzer sounds (if the SMS mini messages buzzer option is active) and a superimposed screen announces "**Do you wish to read the new mini message (SMS)?**", you can choose to read the mini message received by selecting and validating "**YES**" or postpone reading it by selecting and validating "**NO**", by pressing the "**ESC**" button or by waiting until the announcement disappears.

Note: the old mini messages stored and the new mini messages, the reading of which you wished to postpone, can be consulted. Press the "**MENU**" button then validate the telematic icon, select "**Mini messages (SMS)**" and validate the function "**Reading of mini messages received**" by pressing button **G**. Then scroll through the list by turning the button and press the button to select the mini message to be read.

Sending a mini message

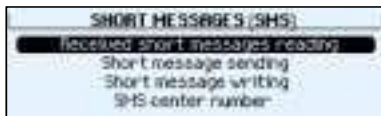

Note: Before typing your first mini message, check that your mini messages (SMS) centre number is stored correctly in the sub-menu "**Server centre N°**". If it is not, any mini messages typed before this number is entered will not be sent.

In the menu "**Mini messages (SMS)**" validate the function "**Typing of a mini message**". Type your mini message using the alphanumeric keypad and validate it using the "**OK**" button to store it or validate the "**Send**" button to send it. Validation of the "**Send**"

button enables you to enter the number of your recipient or select it from the directory or from the list of calls and send the message.

"Duration of calls" menu

Select the "**Duration of calls**" function from the "**Telephone functions**" menu to consult the duration counters for the calls made. The partial counter totals the duration of the calls since the last zero reset carried out using the "**Zero reset**" button.

"Telephone options" menu

Select the "**Telephone options**" function from the "**Telephone functions**" menu to access the functions:

- "**Configure the calls**" which permits activation and deactivation of the "show my number" and "automatic answering after X rings" functions
- "**Ringng options**" which permits adjustment of the ringing volume for voice calls, activation of the mini messages (SMS) receipt buzzer and selection of a ring tone from the five offered.
- "**Diversion number/voice mail**" which permits recording of the call diversion number chosen by the customer, otherwise the call will be transferred to the voice mail.

YOUR 307 SW IN DETAIL

The Directory

General

The "**Directory**" application gives access to 400 files divided into 4 independent sub-directories ("Professional", "Work", "Personal", "Guest"). It enables you to manage these files, make calls and send SMS messages using the SIM card.

Main menu



From the main menu, select the "**directory**" function to access the "**Directory**" main menu and select one of the following functions:

- "Call", to call a number stored in a file
- "Activate guidance to", to initiate guidance to a location stored in a file
- "Management of directory files", to add, delete, modify and consult directory files or exchange them with the SIM card
- "Directory configuration", to select the working directory and define the directory when the system is switched on
- "Mini message (SMS)", to send SMS messages.

Creation / Modification of a file



To create a file, from the "Directory" menu, select the function "Management of directory files" then "Add".

On the file select the section to be filled in, validate then enter the information. You can also associate a voice description with a file in order to use the voice commands.

To modify an existing file, select it using the "Consult" function of the "Management of directory files" menu then make the modifications.

Note: when the address is entered, the navigation CD-Rom must be present in order to obtain guidance to this destination.

YOUR 307 SW IN DETAIL

Services*



Press button **E** to display the "**Services**" menu and select one of the following services:

- "**Customer Contact Centre**" which enables you to contact the **PEUGEOT Customer Contact Centre** directly and access the services offered (this type of call is suspended if an emergency or breakdown call is made).
- "**PEUGEOT Assistance**" which enables you to contact the call centre which controls the PEUGEOT breakdown service directly and receive rapid assistance (you have 6 seconds within which to cancel the call when it is made). During the breakdown call phase it is not possible to make any other calls with the exception of emergency calls.
- "**Operator services**" which gives access to the list of services specific to the operator (e.g.: customer service, consumption monitoring, news, stock market, weather, travel, games, etc) if they are available.

Emergency call*



In an emergency, press button **V** until a signal is heard and a call validation / deletion screen is displayed (delay of 6 seconds) or enter **112** directly.

In the absence of a specific service contract, the parameters of the **SOS** button are set so that a call is made to **112** - unique number made available by the worldwide GSM network, reserved for emergency calls.

Before making a call of this kind, the audio/telephone must detect a cellular network. No security mode is required and, depending on the network, you do not need to insert your SIM card or enter your PIN.

If you have signed the specific contract, refer to its general conditions.

"PEUGEOT Assistance" / Emergency call

During a connection to "PEUGOT Assistance" or an emergency call, it is not possible to send or receive calls or SMS messages; these will be transferred to your voice mail.

In this case, a green diode flashes on the RT3 audio/telephone panel, when the emergency call or "PEUGEOT Assistance" call procedure begins, then lights continuously when the call is taken by the services concerned.

* If option and service available.

YOUR 307 SW IN DETAIL

Voice commands

The voice commands make it possible to use pre-recorded words or phrases to control a certain number of functions of the RT3 audio/telephone.

Activation of the voice commands

Press the button on the end of the lights stalk to activate this function.

Example: to recall the radio station stored on button **3**, the key words are: **"Radio" "Memory" "3"**.

To use these key words, you must say the word **"Radio"**, wait for the audible confirmation signal, then say the word **"Memory"**, wait for the audible confirmation signal, then end with the word **"3"**, wait for the audible confirmation signal which will carry out the action requested.

Notes:

- between two key words, a screen indicates the time remaining and the key word recognised,
 - in the absence of any voice commands, this function will be switched off after approximately five seconds,
 - if a command is not understood, the system transmits **"Pardon"** and displays **"Word not recognised"** on the screen.
- Saying the phrase **"Help"** or **"What can I say"** displays all of the commands available on the screen.

List of commands available

- For the radio, say "RADIO", then :
"PREVIOUS" / "FOLLOWING" / "MEMORY" + 1...6 / "AUTOSTORE"
- For the CD, say "CD PLAYER", then:
" PREVIOUS TRACK" / "FOLLOWING TRACK" / "TRACK NUMBER" + 1..20 / "SHUFFLE" / "SCAN" / "REPEAT"
- for the CD changer, say "CD CHANGER", then:
" PREVIOUS TRACK" / "FOLLOWING TRACK" / "TRACK NUMBER" + 1...20 / "PREVIOUS DISC" / "FOLLOWING DISC" / "DISC NUMBER" + 1...5 / "SHUFFLE" / "SCAN" / "REPEAT"
- For the telephone, say "TELEPHONE", then:
"LAST NUMBER" / "DIRECTORY" + DESCRIPTION / "SERVICES"
- For navigation, say "NAVIGATION", then:
"STOP" / "RE-START" / "DIRECTORY" + DESCRIPTION
- To change the permanent application, say "DISPLAY", then:
"AUDIO" / "TELEPHONE" / "NAVIGATION" / "TRIP COMPUTER"
- To call someone recorded in the directory directly, say "CALL" + DESCRIPTION
- To be guided to the address of someone recorded in the directory, say "GUIDE TO" + DESCRIPTION.
- Various:
"CANCEL" / "HELP" / "WHAT CAN I SAY"

YOUR 307 SW IN DETAIL

Directory description

When a description is linked to a file in the directory, you can record the description vocally to be used for direct access by voice commands (e.g. "Call" "[Name of voice description]" or "Guide to" "[Name of voice description]").

Select "Consult" from the menu "Processing of directory files" to obtain access to the screen for inputting and recording the description.

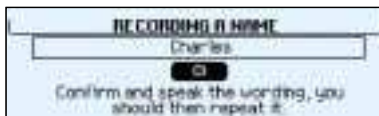

Press the recording button and follow the instructions.

YOUR 307 SW IN DETAIL

CD CHANGER



This is located in the centre of the fascia under the radio. It holds up to 5 discs.

To load the changer, insert the discs with the printed side upwards.

To remove a disc, press and hold one of the buttons "1" to "5".



*The use of copied compact discs may cause faults.
Insert circular compact discs only.*

YOUR 307 SW IN DETAIL

SATELLITE NAVIGATION SYSTEM

Introduction

The satellite navigation system guides you, by means of **vocal and visual instructions** (graphics), to your chosen destination.

The heart of the system lies in the use of a map data base and **GPS (Global Positioning System)**. With this system you can fix the position of your vehicle by means of a satellite network.

The system uses the following elements:

- the CD-Rom drive,
- the configuration CD-Rom,
- the navigation CD-Rom,
- the last voice message recall control,
- the control keypad
- the CT monochrome screen or the DT colour screen.

Certain functions or services described may vary depending on the version of CD-Rom or the country where the vehicle is sold.



For safety reasons, the inputting of navigation information by the driver must be carried out when the vehicle is stationary.

The CD-Rom drive

This is part of the RT3 radio/telephone.



1. Ejection button on CD-Rom.
2. CD-Rom housing.

The navigation CD Rom



This contains all the map data. It must be inserted in the drive, printed face upwards. Use only CD-Roms approved by PEUGEOT.

The last voice message recall control.



Pressing for more than two seconds on the button at the end of the lights stalk repeats the last voice information.

YOUR 307 SW IN DETAIL

The control pad



This lets you select and validate the functions, controls and programmes displayed.

The control pad is an integral part of the RT3 radio/telephone.

Dial; this has two functions:

- Rotation of the dial:

This allows you to **move round** the screen and thus select a function.

It also allows you :

- with a **"setting"** type parameter, after selection, to **increase or decrease** the value,
- with a **"list"** type parameter, to open the list and **scroll through** the values.
- with **map** guidance, to increase the **zoom**.

- Pressing the dial:

This allows:

- **access** to the list of controls (contextual menu) of the permanent display, if there is no other display superimposed.
- **confirmation** of the selected function or the modified value.
- **selection** of a **"setting"** or **"list"** type parameter for modification.

"MODE" button:

- brief press: modification of permanent display (audio system, navigation / guidance...),
- Press for more than two seconds displays **general information**.

"ESC" button:

- brief press: **cancelling** of operation in progress or **erasing** of last superimposed display.
- pressing for more than two seconds: erasing of all superimposed displays and return to the permanent display.

"MENU" button:

- brief pressure: access to the **general menu**.
- press for more than two seconds: access to the **help menu**.

YOUR 307 SW IN DETAIL

General notes on the display

Monochrome screen CT

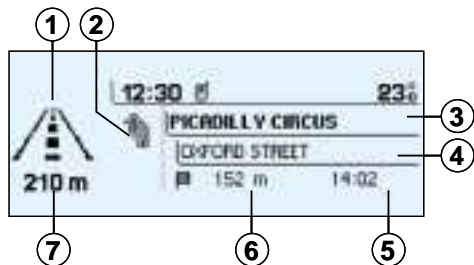

Colour screen DT

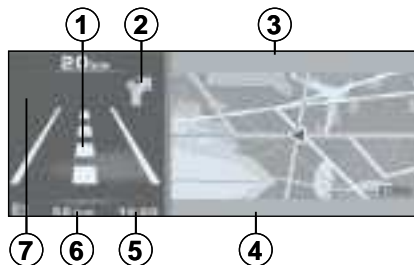

During guidance, if the navigation CD-Rom is present, the screen displays different information depending on the manoeuvres to be carried out.

1. Current manoeuvre or compass.
2. Next manoeuvre to be carried out.
3. Next road to be taken.
4. Current road.
5. Estimated time of arrival at destination.
6. Distance to final destination.
7. Distance to next manoeuvre.

Notes:

- depending on the situation of the vehicle and on the reception of GPS information, this information may disappear from the screen temporarily,
- during guidance, it is only possible to listen to a CD if the vehicle is fitted with a CD changer.

General menu

Switch on the RT3 audio/telephone and insert the navigation CD-Rom.

Press the "MENU" button to access the **general menu**.



Select the Navigation/Guidance icon using the dial, then validate by pressing the dial to access the main "Navigation - Guidance" menu.

YOUR 307 SW IN DETAIL

Navigation - Guidance



The main "**Navigation - Guidance**" menu offers various options for activation or management of guidance:

- choice of the type of destination address (entering of address, service, GPS co-ordinates, stored address),
- modification to the initial route (entering of a diversion)
- displaying of the chosen destination
- setting of the guidance option parameters,
- stop or resume guidance (displaying of the message which changes depending on the previous status).

Selecting a destination



The "**Select a destination**" menu offers various options for reaching a destination:

- entering a postal address,
- selecting a service available in a town (town hall, hotel, cinema, airport...),
- entering GPS details,
- selecting a destination stored in the directory,
- selecting one of the last ten destinations.

Entering an address



The last guidance address is displayed.

Select and validate in succession the entry zones "**Town**", "**Street**", then "**N**" to fill them in.

The "**OK**" function permits validation of the address and access to the guidance activation function.

The "**Archive**" function permits recording of the address in a directory file.

The "**Current location**" function permits display of the current address.

YOUR 307 SW IN DETAIL

Entering the name of the town

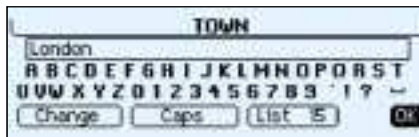

Entering the first letter of the name of the town required will erase that of the town displayed.

To enter the name of another town, select each letter by turning the dial, then validate each letter by pressing the dial.

If an error is made entering the letters, the **"Correct"** function permits erasing of the last letter entered.

Note: following the validation of a letter, only those which could make up a name existing in the database appear.

As letters are entered, the **"List"** function indicates the number of towns beginning with the same letters. Activation of this function permits selection of a town from the list.

When the list contains fewer than five names, these are displayed automatically. Select a town then validate by pressing the dial.

When the complete name of the town is displayed, select the **"OK"** function then confirm by pressing the dial.

Note: once the town has been entered, you can confirm by pressing **"OK"**. You will then be guided to the centre of this town automatically.

Entering the name of the street

Enter the name of the street in the same way as the name of the town.

When the full name of the street is displayed, select the **"OK"** function then confirm by pressing the dial.

Entering the number of the street or junction



Enter the number of the street previously entered.

Select the **"OK"** function, then confirm by pressing the dial.

Note: if the number of the street entered is not available, it is rejected. You can also select a street from the **"Junctions"** function, which avoids having to enter the street number.

Note: if the street selected does not have a number, the list of junctions is displayed automatically.

The full destination is displayed. Select the **"OK"** function, then confirm by pressing the dial to access the guidance activation function. Follow the instructions given by the system.

YOUR 307 SW IN DETAIL

Selecting a service

If you wish to be directed to a service, select the **category** corresponding to the service, then confirm by pressing the dial.

The list of services corresponding to the category selected is displayed.

Select the **service** then confirm by pressing the dial to access the **"Place choice"** function.

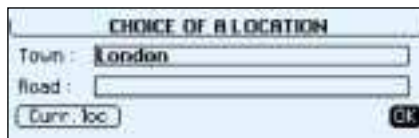

The last address entered is displayed. There are three options for defining the location in which you wish to obtain this service:

- accept the last address entered using the **"OK"** function,
- fill in the **"Town"** and **"Street"** zones,
- automatically enter the name of your current location using the **"Current location"** function.

Note: if the service selected is not available in the programmed location, a temporary message informs you of this.

Following validation of the location, the service closest to it is displayed. The distance indicated is the distance as the crow flies from the service to the selected location.



An indication on the edge of the screen (x/n) shows you the maximum number of establishments providing the same service within a radius of 30 miles (50 km), as the crow flies, from the selected location.

Use buttons "<" and ">" to consult the list provided.

When the establishment of your choice is displayed, you can:

- select the **"OK"** function to activate guidance towards this service,
- select the **"Archive"** function to enter this establishment in your directory.

GPS details



The most recent destinations are shown.

There are three possible methods of defining the location to which you wish to travel:

- accept the last details input by means of the **"OK"** function,
- input the details of your destination,
- automatically input the details of your current location by means of the **"Current location"** function.

YOUR 307 SW IN DETAIL

Selecting a destination stored in the directory

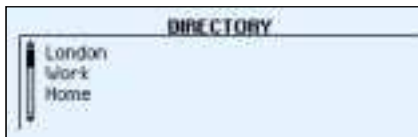

Select the **"Directory"** function to access the file in which the address you are looking for is archived.

Select a description by scrolling down the list by means of the dial, then confirm by pressing the dial. The directory file is then displayed.

Select the **"OK"** function, then press the dial to access the guidance activation function.

Follow the directions given by the system.

Selection of one of the last ten destinations



Select the **"Most recent destinations"** function to access one of the last ten addresses stored.

Select a description by scrolling down the list by means of the dial, then confirm it by pressing the dial. The complete address is then displayed.

Select the **"OK"** function, then press the dial to access the guidance activation function.

Follow the instructions given by the system.

Changing the initial route



Activate the function **"Changing the route"**, then input the distance involved in the change required.

Select the **"OK"** function then validate by pressing the dial.

The system calculates the change which is closest to the value input and gives you the option of whether or not to use this change.

Details of the route

You can consult the destination address at any time by activating the **"Chosen destination"** function.

YOUR 307 SW IN DETAIL

Guidance options

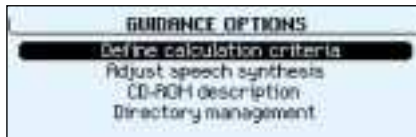

The menu "**Guidance options**" provides access to the following functions:

- changing of the route calculation criteria,
- voice synthesis adjustment of guidance messages,
- description of the information relating to the navigation CD-Rom,
- management of the addresses stored in the directory.

Calculation criteria

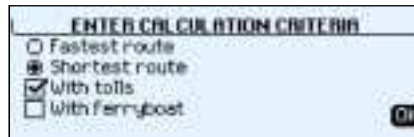

The last criterion used is displayed. Select a criterion from the list, then validate by pressing the dial. When the criterion of your choice has been selected, select the "**OK**" function then confirm by pressing the dial.

Adjusting the voice synthesiser

Select the type of voice "**male**" or "**female**", after inserting the configuration CD-Rom.

Adjust the volume of the voice synthesis by turning the dial, then validate by pressing the dial.

Note: the volume can also be adjusted during a message, using the audio/telephone button or the steering wheel control.

Management of the directory

This function enables you to rename an address stored in the directory.

Select the description corresponding to the stored address to be changed. Select the "Rename" function, then confirm by pressing the dial.

Select the "**OK**" function, then confirm by pressing the dial to record the changes made.

Stopping / Resuming guidance

- "Stop guidance"

During guidance, select this function then validate.

- "Resume guidance"

In the absence of guidance, select this function then validate to activate guidance to the last destination programmed.

Note: after re-starting the engine, a screen appears enabling you to resume guidance activated before the ignition was switched off.

YOUR 307 SW IN DETAIL

"Navigation - Guidance" contextual menu

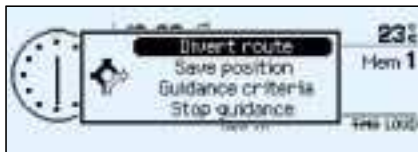

The contextual menu associated with the **"Navigation - Guidance"** application appears as a superimposed display, when this is the application currently in use in the main screen window.

This menu is limited to the following functions:

- changing of the initial route (entering of a diversion),
- switching to "Selection - Movement on map" mode*,
- storing of the current location (postal address if available or, if it is not, the GPS co-ordinates),
- changing of the route calculation criteria,
- stopping or resuming of guidance (displaying of the message which changes depending on the previous status).

General notes on the "Map" application*

The map guidance can be displayed in two ways:

- full screen map**,
- reduced size map on the right-hand side and zoom image of the junction on the left-hand side.

To switch from one to the other, press the dial for more than two seconds.

The **"Map"** application has two operating modes:

- **"Selection - Movement on map"** mode,
- **"Vehicle following on map"** mode.

A **"Zoom"** function enables you to enlarge the map, in accordance with the eleven preset levels relating to the following scales:

- 100 m/cm, 200 m/cm, 500 m/cm,
- 1 km/cm, 2 km/cm, 5 km/cm,
- 10 km/cm, 20 km/cm, 50 km/cm,
- 100 km/cm, 200 km/cm.

This is achieved by turning the dial.

"Selection - Movement on map" mode

This mode permits:

- selection of any point on the map to obtain guidance towards it or to obtain information about it (postal address if available or, if it is not, GPS co-ordinates),
- lateral movement on the map by means of the four directional arrows, representing the four cardinal points (North, East, South, West),
- zooming in on the map in accordance with the eleven preset levels,
- displaying of the **"Map"** contextual menu.

YOUR 307 SW IN DETAIL

"Navigation - Guidance" contextual menu



The contextual menu associated with the **"Navigation - Guidance"** application appears as a superimposed display, when this is the application currently in use in the main screen window.

This menu is limited to the following functions:

- changing of the initial route (entering of a diversion),
- switching to "Selection - Movement on map" mode*,
- storing of the current location (postal address if available or, if it is not, the GPS co-ordinates),
- changing of the route calculation criteria,
- stopping or resuming of guidance (displaying of the message which changes depending on the previous status).

General notes on the "Map" application*

The map guidance can be displayed in two ways:

- full screen map**,
- reduced size map on the right-hand side and zoom image of the junction on the left-hand side.

To switch from one to the other, press the dial for more than two seconds.

The **"Map"** application has two operating modes:

- **"Selection - Movement on map"** mode,
- **"Vehicle following on map"** mode.

A **"Zoom"** function enables you to enlarge the map, in accordance with the eleven preset levels relating to the following scales:

- 100 m/cm, 200 m/cm, 500 m/cm,
- 1 km/cm, 2 km/cm, 5 km/cm,
- 10 km/cm, 20 km/cm, 50 km/cm,
- 100 km/cm, 200 km/cm.

This is achieved by turning the dial.

"Selection - Movement on map" mode

This mode permits:

- selection of any point on the map to obtain guidance towards it or to obtain information about it (postal address if available or, if it is not, GPS co-ordinates),
- lateral movement on the map by means of the four directional arrows, representing the four cardinal points (North, East, South, West),
- zooming in on the map in accordance with the eleven preset levels,
- displaying of the **"Map"** contextual menu.

YOUR 307 SW IN DETAIL

"Vehicle following on map" mode



This mode permits:

- displaying of the vehicle on the map with the route proposed by the navigation if the guidance is active,
- zooming in on the map in accordance with the eleven preset levels,
- displaying of the **"Navigation - Guidance"** contextual menu.

Map*



From the general menu, the main **"Map"** menu offers various options for guidance management:

- switching to "Selection - Movement on map" mode,
- direction of the map towards the North or in the direction of the vehicle,
- recentering of the map around the vehicle,
- opening of the services selection window visible on the map, such as hotels, service stations, etc.
- displaying of the window for entering the description for recording the current position of the vehicle in a directory file.

"Map" contextual menu

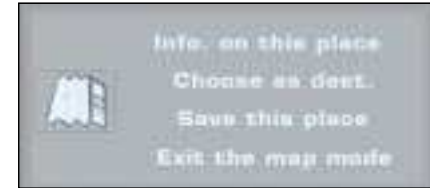

The contextual menu associated with the **"Map"** application and with the **"Selection - Movement on map"** mode appears as a superimposed display, when these are in use in the main screen window.

This menu is limited to the following functions:

- displaying of the information on the location selected on the map,
- selection of a location on the map as a destination,
- storing of the location selected (postal address if available or, if it is not, GPS co-ordinates, so that they can be recorded in a directory file),
- switching to "Vehicle following on map" mode.

* DT colour screen only.

** During the year.

YOUR 307 SW IN DETAIL

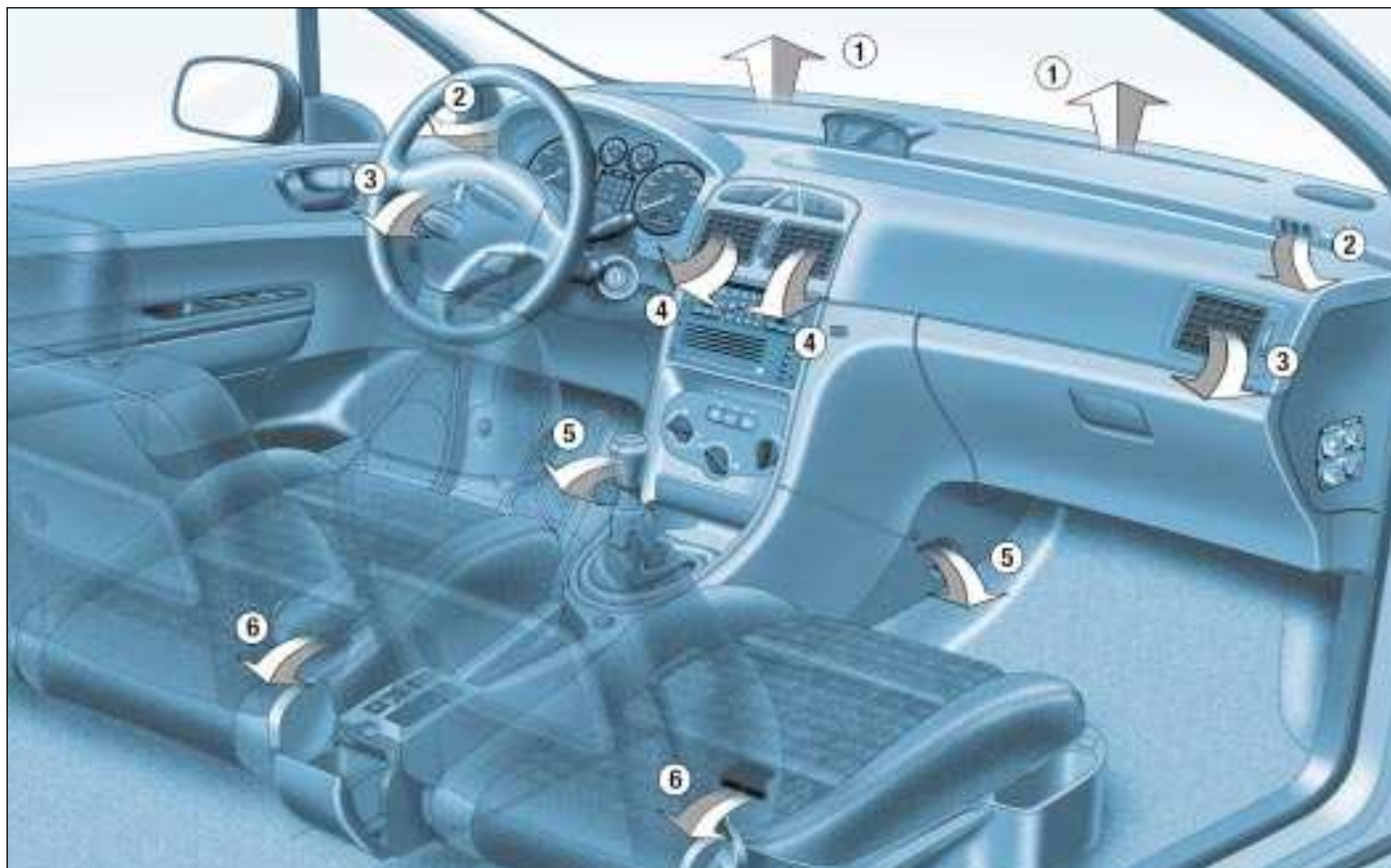

YOUR 307 SW IN DETAIL

VENTILATION

1. Windscreen de-icing or demisting vents.
2. Front window de-icing or demisting vents.
3. Side vents.
4. Centre vents.
5. Air outlet to front footwells.
6. Air outlet to rear footwells.

Advice on operation

☞ Place the air flow control at a level sufficient to ensure a good renewal of air in the passenger compartment. The **"OFF"** position cuts off all the air circulation in the passenger compartment.

Note : only use the **"OFF"** position occasionally (risk of condensation).

☞ For perfectly even air distribution, take care not to obstruct the exterior air intake grilles, the vents and the air ducts under the front seats, as well as the air extractor located in the boot. Check that the pollen filter is in good condition.

YOUR 307 SW IN DETAIL

AIR CONDITIONING

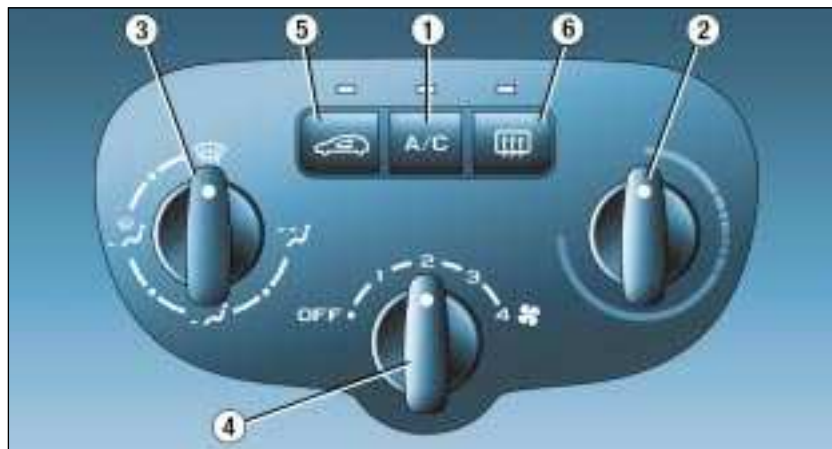

1. Air conditioning control

The air conditioning is designed to operate in all seasons. In summer, it enables the temperature to be lowered and in winter, above 0 °C, it increases the effectiveness of the demisting.



Press the switch, the indicator light comes on.

The air conditioning does not operate while the air flow adjustment control is in the "OFF" position .

Note:

It is quite normal that the condensation created by the air conditioning results in a flow of water under the vehicle when it is stationary.

2. Temperature adjustment

To be adjusted to your requirements.

YOUR 307 SW IN DETAIL

3. Air distribution adjustment



Windscreen and side windows (de-icing/demisting).

To quickly de-ice or demist the windscreen and side windows:

- Place the temperature and air flow controls to maximum,
- Close the centre vents,
- Switch air intake button **5** to the "Outside Air" position (button **5** released, indicator light off),
- Start the air conditioning by pressing the A/C button.



Windscreen, side windows and footwells.



Footwells.



Centre and side vents.

4. Air flow adjustment



Turn the control from position **1** to position **4** to obtain an air flow sufficient to ensure your comfort.

5. Air intake



Pressing button **5** permits recirculation of the interior air. Recirculation, indicated by illumination of the indicator light, prevents exterior odours and smoke from entering the passenger compartment.

Used simultaneously with the air conditioning, recirculation enables cooling performance to be improved.

Used in a humid climate, recirculation may result in misting of the windows.

As soon as possible, switch button **5** to the outside air position, to prevent deterioration of the air quality. The indicator light switches off.

6. Demisting the rear screen and the mirrors



With the engine running, pressing the button once demists the rear screen and the mirrors.

This switches off automatically after approximately twelve minutes.

Pressing again activates demisting for a further twelve minutes.

It is possible to stop demisting by pressing the button again before the end of the twelve minutes.

Important precaution

Operate the air conditioning system for 5 to 10 minutes, once or twice a month, to keep it in perfect working order.

If the system does not produce cold air, do not use it and contact a PEUGEOT dealer.

YOUR 307 SW IN DETAIL

AUTOMATIC AIR CONDITIONING



Automatic operation

1. Temperature adjustment



The chosen temperature is displayed. Press the up and down arrows to change it. A setting around 21 °C enables a comfortable temperature to be obtained.

2. Automatic comfort programme



Press the **"AUTO"** button. The system automatically adjusts the atmosphere inside the vehicle in accordance with the temperature which you have chosen. To do this, it controls the temperature, the flow, the distribution and the intake of air as well as the air conditioning.

Note: for your comfort, the settings are retained between one start-up of the vehicle and the next, if the temperature in the passenger compartment has not changed significantly; otherwise, operation will resume in automatic mode.

3. Automatic visibility programme



In some cases, the automatic comfort programme may not be sufficient for de-icing or demisting of the windows (humidity, several passengers, ice etc.).

In this case, select the automatic visibility programme to clear the windows quickly.

To exit this programme and return to the automatic comfort programme, press the **"AUTO"** button.

YOUR 307 SW IN DETAIL

Manual operation

If you wish, you can make a different choice from that offered by the system by changing a setting. The other functions will still be controlled automatically. Pressing the **"AUTO"** button returns the system to completely automatic operation.

4. Air conditioning



Press this button to switch off the air conditioning. The symbol "ECO" is displayed. Automatic operation of the air conditioning is resumed when the button is pressed again. The symbol "A/C" is displayed.

Notes

It is quite normal that the condensation created by the air conditioning results in a flow of water under the vehicle when it is stationary.

To prevent misting inside the vehicle in cold or wet weather, it is advisable to avoid the "ECO" mode.

5. Air distribution



Pressing this button several times in succession enables the air flow to be directed in turn towards:

- the windscreen (de-icing or demisting),

- the windscreen and the footwells,
- the footwells,
- the centre and side vents and the footwells,
- the centre and side vents.

6. Air flow



The flow of air can be increased or reduced by pressing buttons + or - respectively.

7. Air intake



Press this button for recirculation of the interior air. Recirculation, shown on the display, enables the passenger compartment to be insulated from exterior odours and smoke.

Avoid prolonged recirculation of interior air. To do this, press the button again to resume intake of exterior air.

Note

To prevent misting inside the vehicle in cold or wet weather, it is advisable to avoid the "air recirculation" mode.

8. Switching the system off



The **"OFF"** button enables the entire system to be switched off. A comfortable temperature will no longer be guaranteed.

Pressing the **"OFF"**, **"AUTO"** or **"visibility"** button again switches the system on again with the values selected before it was switched off.

9. Demisting the rear screen and the mirrors



Press this button to demist the rear screen and the mirrors. Demisting switches off automatically. It is possible to stop operation of the demisting before it is switched off automatically by pressing the button again.

Important precaution

Operate the air conditioning for 5 to 10 minutes, once or twice a month, to keep it in good working order.

If the system does not produce cold air, do not use it and contact your PEUGEOT dealer.

YOUR 307 SW IN DETAIL



FRONT SEATS

1 - Forwards-backwards adjustment

Lift the control and slide the seat forwards or backwards.

2 - Seat back angle adjustment

Push the handle towards the rear.

3 - Driver's or passenger's seat height adjustment

Pull the handle upwards or push it downwards as many times as necessary to obtain the required position.

4 - Heated seats control

Press the switch. The temperature is controlled automatically.

Pressing the switch again stops operation.

Note: the command for activation of the heating of the seat(s) remains memorised for two minutes after the ignition has been switched off.

YOUR 307 SW IN DETAIL

5 - Armrests

These can be folded down and are removable.

To remove them, press the button located between the armrest and the side of the seat and pull.

6 - Head restraint height and angle adjustment

To raise or lower the restraint, pull it forwards, sliding it at the same time.

The adjustment is correct when the upper edge of the head restraint is level with the top of the head.

To remove the head restraint, place it in the top position, lift the lug using a coin and pull it forwards and upwards at the same time.

To put it back in position, locate the stems of the restraint in the holes, taking care to keep them in line with the seat back.

Active seat back (front seat)

This possesses a device to prevent "whiplash".

When there is an impact from the rear, the action of the body on the seat back forces the head restraint forwards and upwards, preventing the head being thrown backwards.

7 - Storage drawers

There is a storage drawer under each front seat.

- To open it, lift it and pull.
- extent, press the ends of the slides and lift it, then remove it completely.

Do not place heavy objects in the drawers.

Under the front passenger seat, the layout of the floor allows for storage of a first aid kit and a warning triangle (small version).

8 - Aviation style table

There is an aviation style table, fitted with a can holder, on the back of each front seat

REAR HEAD RESTRAINTS

These have a high position for when they are in use and a low position for when they are stored.

The head restraints are also removable.

To remove them, pull upwards as far as the stop then press the lug (side seat) or the two lugs (centre seat).



Never drive with the head restraints removed; they must be in place and correctly adjusted.

YOUR 307 SW IN DETAIL

5 - Armrests

These can be folded down and are removable.

To remove them, press the button located between the armrest and the side of the seat and pull.

6 - Head restraint height and angle adjustment

To raise or lower the restraint, pull it forwards, sliding it at the same time.

The adjustment is correct when the upper edge of the head restraint is level with the top of the head.

To remove the head restraint, place it in the top position, lift the lug using a coin and pull it forwards and upwards at the same time.

To put it back in position, locate the stems of the restraint in the holes, taking care to keep them in line with the seat back.

Active seat back (front seat)

This possesses a device to prevent "whiplash".

When there is an impact from the rear, the action of the body on the seat back forces the head restraint forwards and upwards, preventing the head being thrown backwards.

7 - Storage drawers

There is a storage drawer under each front seat.

- To open it, lift it and pull.
- extent, press the ends of the slides and lift it, then remove it completely.

Do not place heavy objects in the drawers.

Under the front passenger seat, the layout of the floor allows for storage of a first aid kit and a warning triangle (small version).

8 - Aviation style table

There is an aviation style table, fitted with a can holder, on the back of each front seat

REAR HEAD RESTRAINTS

These have a high position for when they are in use and a low position for when they are stored.

The head restraints are also removable.

To remove them, pull upwards as far as the stop then press the lug (side seat) or the two lugs (centre seat).



Never drive with the head restraints removed; they must be in place and correctly adjusted.

YOUR 307 SW IN DETAIL



REAR SEATS

Forwards-backwards adjustment*

Lift the bar **A** and slide the seat forwards or backwards.

From the 3rd row, you can pull the strap **B** and slide the seat forwards or backwards.

This manoeuvre makes it easier for passengers to exit the 3rd row, when the 2nd row seat is folded.

Seat back angle adjustment

Pull one strap **C** (two straps for each side seat, one for the centre seat) and adjust to the required angle.

Release the strap to lock.

To adjust the angle of the seat from the 3rd row or the boot, pull one strap **C** at the rear of the seat.

Note: the additional seat can be angled and folded by means of a single strap **C** at the rear of the seat on the right or on the left.

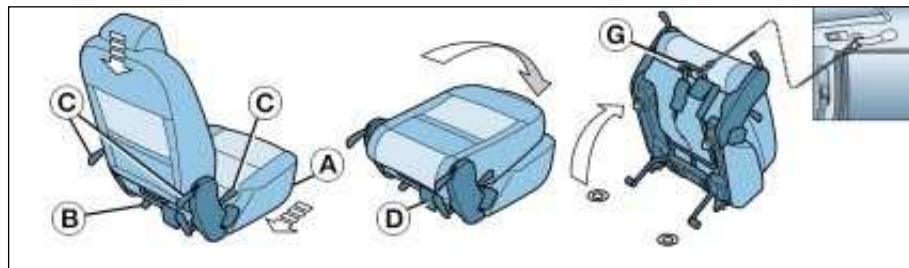

Folding a side seat:

access to the 3rd row:

Place the head restraint in the low position.

Push the seat back fully using bar **A**.

Fold the seat back onto the cushion using the strap **C**.

Note: you can lock the seat back in this position (e.g. for removal) by pressing down on it.

Push control **D** upwards to release the rear feet.

Place the seat in the "folded" position.

exit from the 3rd row or folding from the boot:

Place the head restraint in the low position.

Push the seat back fully using the strap **B**.

Fold the seat back onto the cushion using the strap **C**.

Note: you can lock the seat back in this position (for removal) by pressing down on it.

Push the control **D** upwards to release the rear feet.

Place the seat in the folded position.

While driving attach the retaining strap (contained in the storage pocket of the corresponding front seat):

- on the 2nd row: on one side, to the carrying handle **G** and on the other side, to the grab handle,
- on the 3rd row: on one side, to the carrying handle **G** and on the other side, to the rear armrest grab handle.

* Excluding additional seat.

YOUR 307 SW IN DETAIL

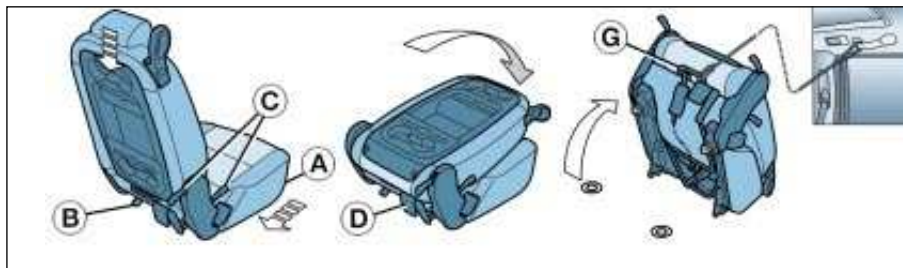

Centre seat table position

Place the head restraint in the low position.

Fold the seat back onto the cushion using the strap **C**.

You now have a small table with four can holders, two pen holders and a document holder.

Folding the centre seat

Place the head restraint in the low position.

Push the seat back fully using the bar **A** or the strap **B**.

Fold the seat back onto the cushion using the strap **C**.

Note: you can lock the seat back in this position (for removal) by pressing down on it.

Push control **D** upwards to release the rear feet.

Place the seat in the folded position.

While driving, attach the retaining strap (contained in the storage pocket of one of the front seats) on one side to the carrying handle **G and on the other side, to the grab handle.**

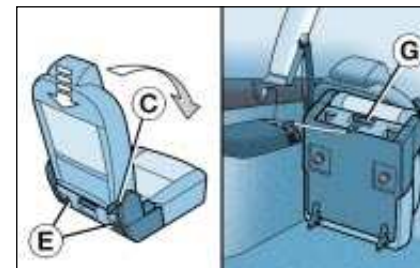

Folding an additional seat

Place the head restraint in the low position.

Pull the strap **C** (at the rear of the seat to the right or to the left) backwards then press on the seat back to release it, while continuing to pull the strap.

Fold the seat back onto the seat cushion.

Note: you can lock the seat back in this position (for removal) by pressing down on it.

Push the two levers **E** upwards to unlock the rear feet.

Place the seat in the folded position.

While driving, attach the retaining strap (contained in the storage pocket of the additional seat) on one side to the carrying handle **G and on the other side, to the rear armrest grab handle.**

YOUR 307 SW IN DETAIL

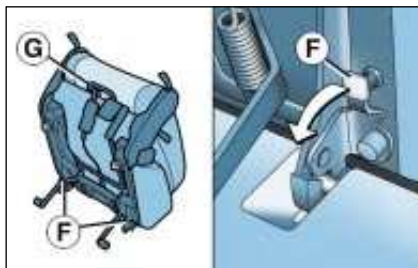

Removing a seat

Fold the corresponding seat.

Tilt the two red levers **F** under the seat to release the front feet.

Lift it and carry it using the carrying handle **G**.

In the 3rd row, position the fixing point closers to obtain a flat boot floor.

Refitting a seat

In the 3rd row, first remove the floor fixing point closers using a thin screwdriver.

Before positioning the 3rd row seats, move those of the 2nd row forward.

Check that nothing is obstructing the floor fixing points thus preventing correct locking of the seat feet.

Carry the seat using the carrying handle **G**.

Position the front feet in the securing points.

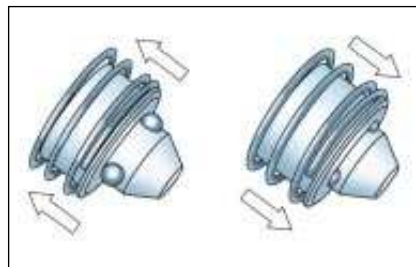

Locked

Free

Push control **D** upwards to check that the rear feet are free.

Tilt the folded seat backwards.

The rear feet lock automatically, as do the two red levers **F**.

Check that the seat is locked correctly.

Lift the seat back, first releasing it by pulling the strap **C**.

To lock the additional seats, press the two levers **E**.



Only lock the seat back on the cushion occasionally, to avoid undue wear of the seat covers.

Avoid placing luggage on folded seats.

Never use the adjusting straps to remove, refit or carry a seat.

YOUR 307 SW IN DETAIL

GENERAL POINTS RELATING TO CHILD SEATS

Although one of PEUGEOT's main criteria when designing your vehicle, the safety of your children also depends on you.

For maximum safety, please follow these precautions:

- Since 1992, **all children under the age of 10 must travel in approved child seats* suited to their weight**, on seats fitted with a seat belt.

In order to recognise a child seat which conforms to current legislation, **check that it bears an orange label indicating the weight range for its use and its approval number.**

- **A child weighing less than 9 kg must travel in the rearwards facing position both in the front and in the rear. PEUGEOT recommends that children should travel in the "rearwards facing" position up to the age of two.**
- **Statistically, the safest seats in your vehicle for the transportation of children are the rear seats.**
- If a child is travelling on a booster seat, check that the lap section of the seat belt passes over the child's thighs correctly. The chest section of the seat belt must be positioned on the child's shoulder without touching the neck. PEUGEOT recommends that you use a booster seat with a back, fitted with a seat belt guide.
- Remember to fasten the seat belt or the child seat harness **keeping the slack in relation to the child's body to a minimum**, even for short journeys.

* According to current legislation in the country.

** Consult the relevant administration in your country for information regarding the rules for transporting children on the front passenger seat.

Rules for transporting children on the front passenger seat**

Children under the age of 10 must not travel in the forwards facing position, unless the rear seats are already occupied by other children or the rear seats cannot be used (absent or folded). In this case, adjust the front passenger seat to the most rearward position and arm the passenger air bag.

The rearwards facing position is permitted from birth to 13 kg or 18 kg. In this position, it is essential to disarm the passenger air bag.

YOUR 307 SW IN DETAIL

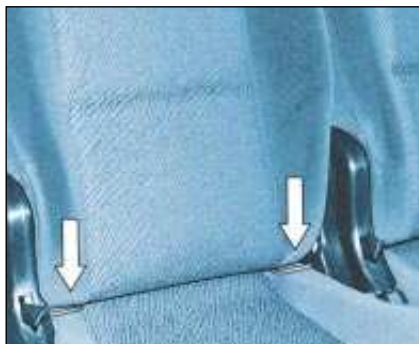

ISOFIX MOUNTINGS

The two rear side seats of your vehicle are fitted with **ISOFIX mountings**. These are two rings located between the seat back and the seat cushion.

The **ISOFIX child seats** are fitted with two locks which are secured easily on these rings. All this guarantees reliable, safe and fast fitting.



The ISOFIX child seat approved for Peugeot vehicles and sold by Peugeot dealers is the **ISOFIX KIDDY*** child seat. It can be fitted in the "rear facing" position (when the side seats are recentred) from birth to 13 kg and in the "forwards facing" position from 9 to 18 kg.

In the front, in the "rear facing" position, the front passenger seat must be moved as far forward as possible so that the body of the child seat is in contact with or as close as possible to the fascia.

In the rear, in the "forwards facing" position, it is imperative that the front passenger seat is in the mid-way position on the runner, seat back upright.

The ISOFIX KIDDY seat can also be installed on a 2nd row side seat which has been positioned in the 3rd row. In this case, the ISOFIX KIDDY seat must be in the "rear facing" position, the body supported on the seat back of the corresponding 2nd row seat.

This seat can also be used on seats not fitted with ISOFIX mountings. In this case it is compulsory to attach it to the vehicle's seat by means of the three-point seat belt for the "rear facing" and "forwards facing" positions.

Refer to the "Summary table for fitting child seats".

When the ISOFIX KIDDY seat is fitted in the "rear facing" position on the front passenger seat, it is imperative that that passenger air bag be disarmed.

Otherwise there is a risk the child could be seriously injured or even killed due to deployment of the air bag.

Follow the instructions for fitting the child seat in the seat manufacturer's instruction booklet.

* You can only fit ISOFIX child seats approved by PEUGEOT and sold by PEUGEOT dealers on your vehicle's ISOFIX mountings.

YOUR 307 SW IN DETAIL



CHILD SEATS RECOMMENDED BY PEUGEOT

In addition to the ISOFIX child seats, PEUGEOT offers a complete range of child seats which are secured using the seat belt:

Group 0+: from birth to 13 kg

L1 - "Britax Babysure": installed in the rear-facing position in the front or in the rear using a three-point seat belt.

In the front, it is compulsory to disarm the passenger air bag and the passenger seat must be adjusted to the "mid-way" position on the runner.

Group 1: from 9 to 18 kg

L2 - "Römer Prince": installed in the rear using a two or three-point seat belt.

For the safety of your child, the seat and the restraining cushion must never be separated.

Group 2: from 15 to 25 kg

L3 - "Römer Vario": installed in the rear with a two or three-point seat belt.

YOUR 307 SW IN DETAIL



Groups 2 and 3: from 15 to 36 kg

L4 - "Recaro Start": installed in the rear with a three-point seat belt.

The height and width of the seat back and length of the seat cushion must be adjusted according to the age and build of your child.

L5- "Klippan Optima": installed in the rear with a three-point seat belt.

From the age of 6 years (approximately 22 kg), the booster is used on its own.

Refer to the "Summary table for the installation of child seats".



Never leave one or more children alone and unsupervised in a vehicle.

Never leave a child or an animal in a vehicle which is exposed to the sun and has the windows closed.

To protect your young children from the sun, fit blinds on the rear windows.

Never leave the keys within reach of children inside the car.



Disarm the passenger air bag when installing a "rearwards facing" child seat on the front passenger seat. Otherwise, the child would risk being killed or seriously injured were the air bag to inflate.

Observe strictly the recommendations for assembling and securing the child seat as shown in the child seat instructions.

To prevent the doors from opening accidentally, use the child lock.*

Also, do not open the rear windows more than a third.*

* According to model.

YOUR 307 SW IN DETAIL

SUMMARY TABLE FOR FITTING CHILD SEATS

In accordance with the European regulation (Directive 2000/3), the table below indicates the options for the installation of child restraints, depending on the weight group and the seat in the vehicle:

	Seat	Statutory weight group			
		Group 0 ^(a) at 0+ < 13 kg	Group 1 9 - 18 kg	Group 2 15 - 25 kg	Group 3 22 - 36 kg
1st row	Front passenger ^(b) Fixed seat	U L1, L6	U L2, L7	U L3, L4, L5	U L4, L5
	Front passenger ^(b) Height adjustable seat (R)	U (R) L1, L6	U (R) L2, L7	U (R) L3, L4, L5	U (R) L4, L5
2nd row	Side Seat off centre and recentered	U L1, L6	U L2, L7	U L3, L4, L5	U L4, L5
	Centrale Centre seat	U L1, L6	U L2, L7	U L3, L4, L5	U L4, L5
3rd row	Side Additional seat	L1	L2	L3, L4, L5	L4, L5
	Side 2nd row side seat	U	U	L3, L4, L5	L4, L5
	Side 2nd row centre seat	U	U	L3, L4, L5	L4, L5

U : universal "rear facing" or "forwards facing" child seat.

U (R) : universal child seat with a height adjustable passenger seat; it must be adjusted to between mid and maximum height (in conformity with § 3.3. of appendix 2 of annex XVIII of Directive 2000/3).

According to destination:

L1	: BRITAX Babysure	E11 0344117	Universal (birth to 13 kg).
L2	: RÖMER Prince	E1 03301058	Universal (9 to 18 kg).
L3	: RÖMER Vario	E1 03301120	Universal (15 to 25 kg).
L4	: RECARO Start	E1 03301108	Universal (15 to 36 kg).
L5	: KLIPPAN Optima	E17 030007	Universal (15 to 36 kg).
L6	: KIDDY Isofix Rearwards facing ^(c)	E1 03301123 and	Universal (birth to 13 kg).
L7	: KIDDY Isofix Forwards facing ^(c)	E2 030011	Universal (9 to 18 kg).

^(a) Group 0: from birth to 10 kg.

^(b) Consult the current legislation in your country.

^(c) See section "Seats - Isofix mountings" for use of the KIDDY child seat on the vehicle's Isofix mountings, or failing this with the seat belt.

YOUR 307 SW IN DETAIL

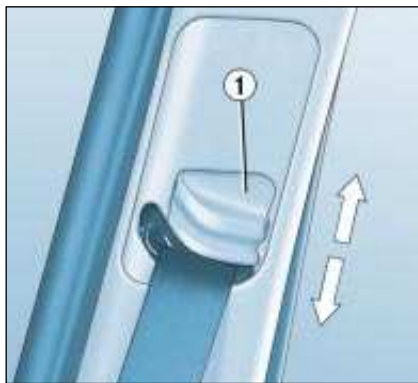

SEAT BELTS

Front and 2nd row rear side seat belts

The front seats are fitted with pre-tensioners and force limiters while the rear seats have force limiters only.

To adjust the height in the front

- ☞ To lower the attachment point, squeeze control 1 and slide it downwards.
- ☞ To raise the attachment point, slide control 1 upwards.

To lock

- ☞ Pull the strap, then insert the buckle into the stalk.

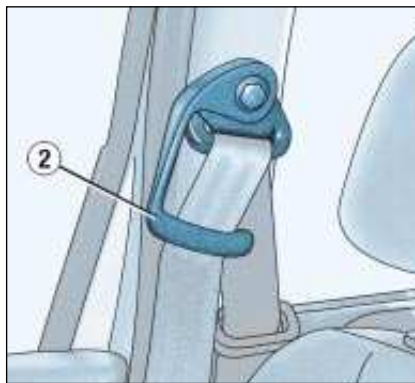

Routing the 2nd row rear side seat belt:

- ☞ for children or people of a short stature, pass the seat belt under the strap guide 2,
- ☞ for other passengers, pass the seat belt over the strap guide.

This strap guide prevents the seat belt from passing over the neck of these passengers.



- On the left-hand side: in the 3-seat configuration in the 2nd row, use the strap guide for people of a short stature only.
- On the right-hand side: in the re-aligned side seats configuration, do not use the strap guide.

Pre-tensioning and force-limiting seat belts

Safety in the event of a frontal impact has been improved by the introduction of pre-tensioning and force-limiting seat belts. Depending on the seriousness of the impact, the pre-tensioning system instantly tightens the seat belts firmly against the body of the occupant.

The pre-tensioning seat belts are armed when the ignition is on.

The force-limiting device reduces the pressure of the seat belt against the occupant's body in the event of an accident.

YOUR 307 SW IN DETAIL



2nd row rear centre seat belt

The 2nd row rear centre seat has a three-point inertia reel seat belt incorporated in the centre of the roof.

Pass buckle **A**, then buckle **B**, into the strap guide working from the inside to the outside of the seat.

Insert buckle **A** into its stalk (right), then buckle **B** into its stalk (left).

To remove the seat belt, proceed in the reverse order, then move buckle **B** to the magnet of the roof fixing point.

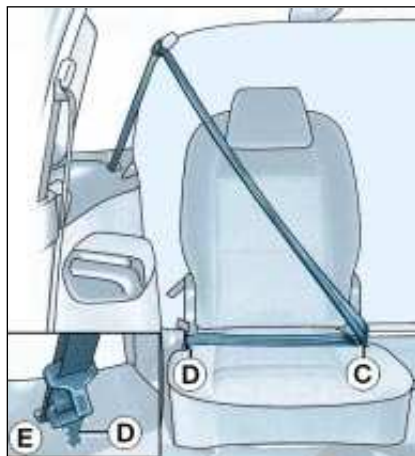

3rd row rear seat belts

The 3rd row rear seats are fitted with two three-point inertia reel seat belts.

To put on the seat belt, insert buckle **C** then buckle **D** into their respective stalks.

To remove the seat belt, proceed in the reverse order, then move buckle **D** to the location **E** provided.



To be effective, a seat belt must be tightened as close to the body as possible.

If the seats are fitted with arm-rests, the lap section of the seat belt must always pass under the armrest.

Do not use the strap guide when a child seat is fitted.

Do not invert the seat belt buckles as they will not carry out their function fully.

Depending on the nature and the seriousness of the impact, the pre-tensioners may be triggered before and independently of triggering of the air bags.

In all cases, the air bag warning light comes on.

Following a collision, have the system checked by a PEUGEOT dealer.

YOUR 307 SW IN DETAIL

SEAT MODULARITY AND DIFFERENT CONFIGURATIONS

The design of your vehicle and of its seats offers multiple seat configurations.

There are **side seats** which can be installed in the 2nd or 3rd row, on the right or on the left.

Once the **centre seat** has been removed from the 2nd row, you can recentre the side seats for more comfort.

There is also a centre seat, fitted in the central position of the 2nd row, which can also be installed in the left position in the 3rd row.

In this case, you must use the 3rd row rear left seat belt without passing it through the strap guide.

You can add up to two **additional seats** in the 3rd row, on the right or on the left.

Examples of varied arrangements combining comfort and practicality:

5 seats



4 seats with table position



The various operations resulting in modification of the existing configuration must be carried out when the vehicle is stationary (see "Seats" section).

YOUR 307 SW IN DETAIL

5 seats with centre seat in the 3rd row



4 seats with side seat in the 3rd row

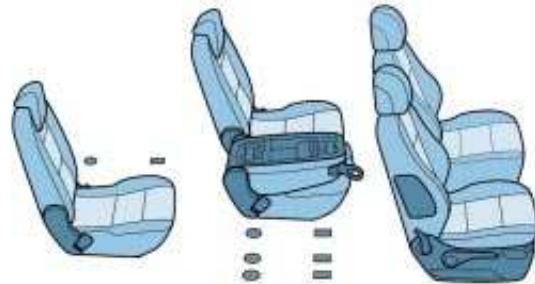

Transportation of long objects

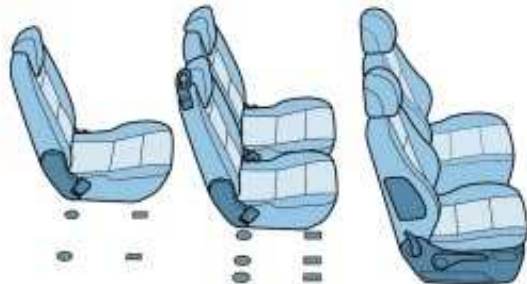

Loading of a large volume

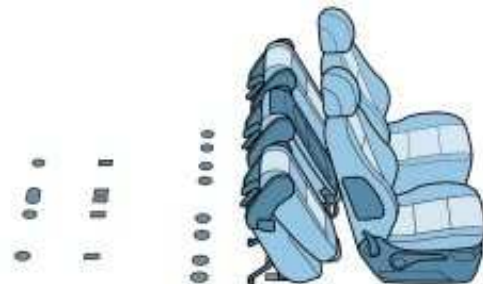

YOUR 307 SW IN DETAIL

6 seats with an additional seat and the centre seat in the 3rd row



7 seats with two additional seats

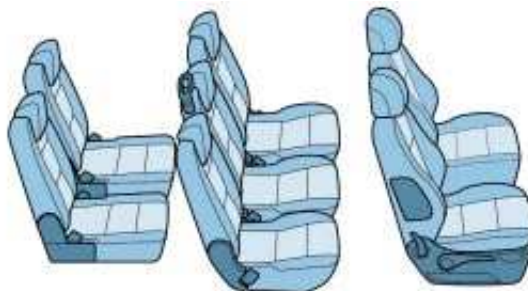

5 seats with table position and one additional seat



5 seats with two folded additional seats

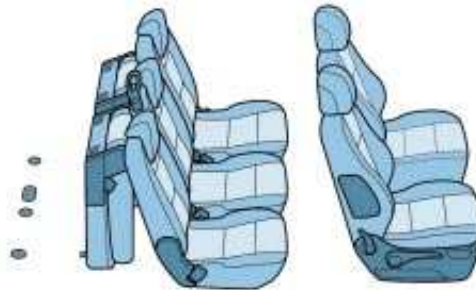

YOUR 307 SW IN DETAIL

THE KEYS

The keys allow you to switch on the ignition and to independently operate the locks on the front doors, the fuel filler cap, the glove box and the passenger air bag disarming switch.

Central locking

From the driver's door, the keys allow you to lock, deadlock or unlock the doors and tailgate, as well as fold back the exterior mirrors.

If one of the doors or the boot is open, the central locking does not work; an audible signal indicates this when locking by remote control.

The remote control performs the same functions at a distance.

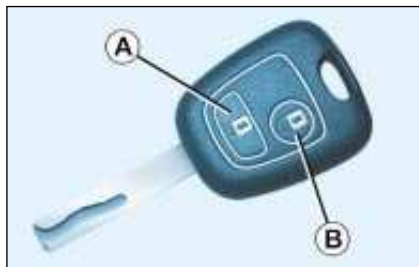

The remote control

Locking

Press button **A** to lock the vehicle. This is confirmed by fixed lighting of the direction indicators for approximately two seconds.

Note : a long press on button **A**, in addition to locking, automatically closes the windows.

Vehicles fitted with deadlocking

Warning: *deadlocking renders the internal and external door locking controls inoperative.*

One press on button **A** deadlocks the vehicle.

This is confirmed by fixed lighting of the direction indicators for approximately two seconds.

Note: a long press on button **A**, in addition to deadlocking, automatically closes the windows.

A second press on button **A** within five seconds of deadlocking changes this to normal locking.

This is confirmed by fixed lighting of the direction indicators for approximately two seconds.

Unlocking

Press button **B** to unlock the vehicle. This is confirmed by rapid flashing of the direction indicators.

Note: *if the vehicle is locked and unlocking is activated inadvertently without the doors being opened within 30 seconds, the vehicle will lock itself automatically.*

Locating your vehicle

To locate your car, if you have locked it, in a car park:

☞ press button **A**. The courtesy lights come on and the direction indicators flash for a few seconds.

YOUR 307 SW IN DETAIL

Electronic engine immobiliser

This locks the engine control system as soon as the ignition has been switched off and therefore prevents starting of the vehicle by anyone who does not have the key.

The ignition key has an electronic chip which has a special code. When the ignition is switched on, the code must be recognised for starting to be possible.

If the system does not function correctly, the central locking button indicator light, situated in the centre of the fascia, flashes rapidly when the ignition is switched on (2nd notch), accompanied by an audible signal and the message "**Anti-theft device faulty**" on the multi-function display.

In this case your vehicle will not start.

Contact a PEUGEOT dealer as soon as possible.



Confidential card

The confidential card contains the identification code necessary for any work carried out by a PEUGEOT dealer on the system. This code is hidden by a film which should be removed only if necessary.

Keep your card in a safe place, never inside the vehicle.

Key in ignition

A buzzer sounds on opening the driver's door, if the key has been left in the ignition.



Changing the battery of the remote control

Warning that the battery is flat is given by an audible signal accompanied by the message "**Remote control battery low**" on the multi-function display.

To replace the battery, remove the screw then unclip the casing using a coin at the ring (CR 2016/3 volt battery).

If the remote control does not work after the battery has been changed, reprogramme the remote control.

Programming the remote control

- ☞ Switch off the ignition.
- ☞ Switch the ignition on again.
- ☞ Immediately press button **A**.
- ☞ Switch off the ignition and remove the remote control key from the ignition lock. The remote control is now working again.

YOUR 307 SW IN DETAIL



Make a careful note of the number on each key. The key number is coded on the label attached to the key. If the key is lost, your PEUGEOT dealer can rapidly supply you with new keys.

The high-frequency remote control is a sensitive system; do not operate it while it is in your pocket as there is a possibility that it may unlock your vehicle without your knowledge.

The remote control cannot operate if the key is in the ignition, even if the ignition is switched off, except for reprogramming.

Nevertheless, do not operate the deadlocking device if there is someone inside the vehicle.

As a safety measure (when there are children on board), remove the ignition key when leaving the vehicle, even for a short time.

Do not handle the buttons of your remote control when out of range of your vehicle. You run the risk of stopping it from working.

It would then be necessary to reprogramme the remote control.

When buying a second-hand car:

- Ensure that you are given the confidential card;*
- have the key codes memorised by a PEUGEOT dealer, to ensure that the keys in your possession are the only ones that can start your vehicle.*

Do not make any modifications to the electronic engine immobiliser system.

YOUR 307 SW IN DETAIL

Electronic engine immobiliser

This locks the engine control system as soon as the ignition has been switched off and therefore prevents starting of the vehicle by anyone who does not have the key.

The ignition key has an electronic chip which has a special code. When the ignition is switched on, the code must be recognised for starting to be possible.

If the system does not function correctly, the central locking button indicator light, situated in the centre of the fascia, flashes rapidly when the ignition is switched on (2nd notch), accompanied by an audible signal and the message "**Anti-theft device faulty**" on the multi-function display.

In this case your vehicle will not start.

Contact a PEUGEOT dealer as soon as possible.



Confidential card

The confidential card contains the identification code necessary for any work carried out by a PEUGEOT dealer on the system. This code is hidden by a film which should be removed only if necessary.

Keep your card in a safe place, never inside the vehicle.

Key in ignition

A buzzer sounds on opening the driver's door, if the key has been left in the ignition.



Changing the battery of the remote control

Warning that the battery is flat is given by an audible signal accompanied by the message "**Remote control battery low**" on the multi-function display.

To replace the battery, remove the screw then unclip the casing using a coin at the ring (CR 2016/3 volt battery).

If the remote control does not work after the battery has been changed, reprogramme the remote control.

Programming the remote control

- ☞ Switch off the ignition.
- ☞ Switch the ignition on again.
- ☞ Immediately press button **A**.
- ☞ Switch off the ignition and remove the remote control key from the ignition lock. The remote control is now working again.

YOUR 307 SW IN DETAIL



Make a careful note of the number on each key. The key number is coded on the label attached to the key. If the key is lost, your PEUGEOT dealer can rapidly supply you with new keys.

The high-frequency remote control is a sensitive system; do not operate it while it is in your pocket as there is a possibility that it may unlock your vehicle without your knowledge.

The remote control cannot operate if the key is in the ignition, even if the ignition is switched off, except for reprogramming.

Nevertheless, do not operate the deadlocking device if there is someone inside the vehicle.

As a safety measure (when there are children on board), remove the ignition key when leaving the vehicle, even for a short time.

Do not handle the buttons of your remote control when out of range of your vehicle. You run the risk of stopping it from working.

It would then be necessary to reprogramme the remote control.

When buying a second-hand car:

- Ensure that you are given the confidential card;*
- have the key codes memorised by a PEUGEOT dealer, to ensure that the keys in your possession are the only ones that can start your vehicle.*

Do not make any modifications to the electronic engine immobiliser system.

YOUR 307 SW IN DETAIL

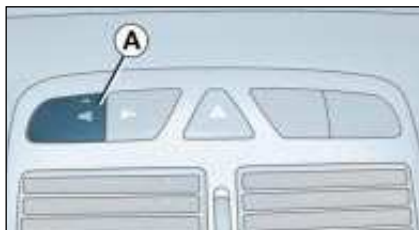

THE ALARM

This provides two types of protection:

- **exterior protection:** it sounds if a door, the boot or the bonnet is opened.
- **interior protection:** it sounds if the volume inside the passenger compartment changes (breaking of a window or a movement inside the vehicle).

Setting the alarm

- ☞ Switch off the ignition and get out of the vehicle.
- ☞ Set the alarm within five minutes of getting out of the vehicle, by locking or deadlocking using the remote control (button **A** indicator light flashes once per second).

Note: if you wish to lock your vehicle without setting the alarm, use the door lock.

When the alarm is triggered, the siren sounds and the direction indicator lights flash for thirty seconds.

After triggering, the alarm remains set.

Warning: if the alarm has been triggered ten times in succession, on the eleventh time it becomes inactive.

Note: if button **A** indicator light flashes rapidly, the alarm has been triggered while you were away from your vehicle.

Disarming

Unlock the vehicle with the remote control key (button **A** indicator light goes out).

Note: if the alarm has been triggered while you were away from your vehicle, the rapid flashing of the indicator light will stop when you switch on the ignition.

To set the alarm with exterior protection only

If, while you are away from the vehicle, you wish to leave a window partially open or a pet inside the vehicle, you should choose exterior protection only.

- ☞ Switch off the ignition,
- ☞ In the next ten seconds, press button **A** until the indicator light is on continuously,
- ☞ Get out of the vehicle,

- ☞ Set the alarm by locking or deadlocking using the remote control (button **A** indicator light flashes once a second).

Note: when the alarm is set but the remote control does not operate:

- ☞ Unlock the doors with the key and open the door. The alarm is triggered.
- ☞ Switch on the ignition in the next ten seconds. The alarm is disarmed.

Incorrect operation

When the ignition is switched on, if button **A** lights for ten seconds, there is a fault in the siren connection.

Contact a PEUGEOT dealer to have the system checked.

Automatic activation*

The alarm is activated automatically two minutes after the last closure of a door or the boot.

In order to avoid accidental triggering of the alarm when a door or the boot is opened, it is essential to first press the unlocking button on the remote control.

* According to destination.

YOUR 307 SW IN DETAIL

THE DOORS

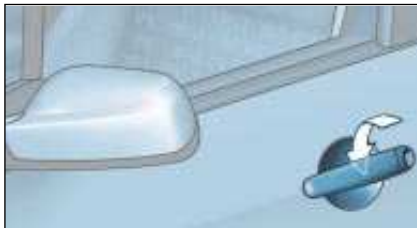

Opening the doors from outside



Opening the doors from inside

The front door opening controls permit complete unlocking of the vehicle.

However, the rear door opening controls only unlock the door concerned.

Note: the door opening controls do not function when the vehicle is deadlocked.

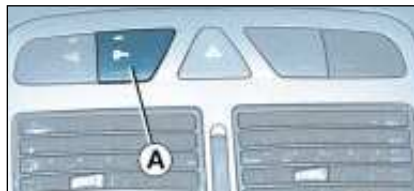

Locking / Unlocking from the inside

Press button **A**.

This allows locking or unlocking of the doors and the tailgate.

Note: if the vehicle is deadlocked, button **A** does not function. In this case use the remote control for unlocking.

"Door open" alert

With the engine running, an audible signal and a diagram locating the door briefly displayed on the multi-function display warn you that a door is not properly closed.

In addition, if the vehicle is moving, the courtesy lights flash.



Child safety

This prevents either of the rear doors being opened from inside.

☞ Turn the red plastic switch a quarter of a turn using the ignition key.

YOUR 307 SW IN DETAIL

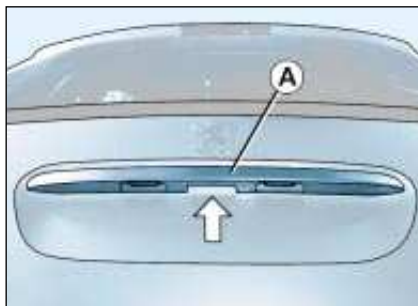

TAILGATE

Simultaneous locking or unlocking of the tailgate and the doors

The tailgate is locked or unlocked by the remote control or the driver's door lock.

To open, pull handle **A** and lift the tailgate.

Note: the tailgate locks automatically when the vehicle is being driven at 6 mph (10 km/h) and unlocks when one of the doors is opened.

"Tailgate open" warning

When the engine is running, an audible signal and a diagram displayed briefly on the multi-function display warn you that the tailgate is not properly closed.

In addition, if the vehicle is being driven, the courtesy lights flash.

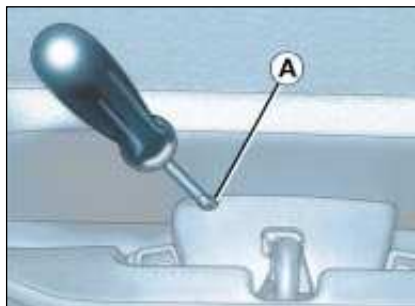

Tailgate release

This enables the tailgate to be unlocked in the event of a central locking fault.

- Fold back the rear seats to gain access to the lock from inside the boot,
- Insert a small screwdriver into hole **A** of the lock to unlock the tailgate.

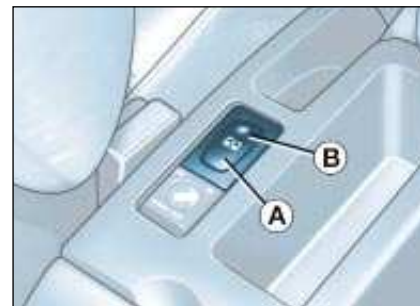

PANORAMIC ROOF

Your vehicle is fitted with a tinted glass panoramic roof which increases the light and visibility in the passenger compartment. Its electric concealing shutter improves temperature conditions.

To open: press part **A** of the switch.

To close: press part **B** of the switch.

Manually: press the switch without going past the point of resistance; the shutter stops as soon as the switch is released.

Automatically: press the switch beyond the point of resistance; one press fully opens or closes the shutter. Press the switch again to stop the shutter.

YOUR 307 SW IN DETAIL

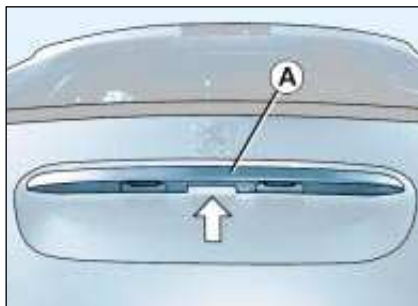

TAILGATE

Simultaneous locking or unlocking of the tailgate and the doors

The tailgate is locked or unlocked by the remote control or the driver's door lock.

To open, pull handle **A** and lift the tailgate.

Note: the tailgate locks automatically when the vehicle is being driven at 6 mph (10 km/h) and unlocks when one of the doors is opened.

"Tailgate open" warning

When the engine is running, an audible signal and a diagram displayed briefly on the multi-function display warn you that the tailgate is not properly closed.

In addition, if the vehicle is being driven, the courtesy lights flash.

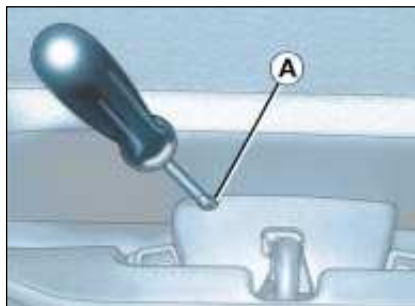

Tailgate release

This enables the tailgate to be unlocked in the event of a central locking fault.

- Fold back the rear seats to gain access to the lock from inside the boot,
- Insert a small screwdriver into hole **A** of the lock to unlock the tailgate.

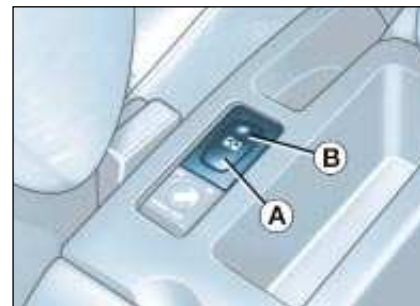

PANORAMIC ROOF

Your vehicle is fitted with a tinted glass panoramic roof which increases the light and visibility in the passenger compartment. Its electric concealing shutter improves temperature conditions.

To open: press part **A** of the switch.

To close: press part **B** of the switch.

Manually: press the switch without going past the point of resistance; the shutter stops as soon as the switch is released.

Automatically: press the switch beyond the point of resistance; one press fully opens or closes the shutter. Press the switch again to stop the shutter.

YOUR 307 SW IN DETAIL

Safety auto-reverse

At the end of its travel, if the shutter encounters an obstacle to closing, it stops and moves back slightly.

Notes

If the shutter's power supply is cut off, while it is moving or immediately after it has stopped, you must reinitialise the safety auto-reverse:

- press section **B** of the switch until the shutter is completely closed (closing in stages of a few centimetres).

In the event of unwanted opening of the shutter on closing, and immediately after the shutter has stopped:

- press section **A** of the switch until the shutter is fully open,
- release section **A** and immediately afterwards press section **B** of the switch until the shutter is fully closed (closing in stages of a few centimetres).

The safety auto-reverse function is not active during these operations.



OPENING THE BONNET

From inside: push the handle on the left-hand side under the fascia.

From outside: lift the catch and raise the bonnet.

Bonnet strut

Secure the strut to hold the bonnet open.

Before closing the bonnet, replace the strut in its housing.

To close

Lower the bonnet and release it at the end of its travel. Check that the bonnet is properly locked.

"Bonnet open" warning

With the engine running or the vehicle moving, flashing of the central **"STOP"** warning light accompanied by an audible signal and a diagram on the multi-function display, warns you that the bonnet is not properly closed.

FILLING WITH FUEL

Low fuel level



When the minimum fuel level in the tank is reached, this warning light comes on.

You can still drive approximately 30 miles (50 km).

Flashing of the warning light indicates a malfunction of the fuel gauge.

Contact a PEUGEOT dealer.

The engine must be switched off when filling with fuel.

- ☞ Open the fuel filler flap.
- ☞ Insert the key then turn it to the left.
- ☞ Remove the cap and hang it on the hook located on the inside of the flap.

A label affixed to the inside of the fuel filler flap indicates which type of fuel to use.

When you fill your tank, do not continue after the third cut-off of the pump. This could cause your vehicle to malfunction.

The capacity of the tank is approximately 60 litres.

- ☞ After filling the tank, lock the cap and close the fuel filler flap.

YOUR 307 SW IN DETAIL

Safety auto-reverse

At the end of its travel, if the shutter encounters an obstacle to closing, it stops and moves back slightly.

Notes

If the shutter's power supply is cut off, while it is moving or immediately after it has stopped, you must reinitialise the safety auto-reverse:

- press section **B** of the switch until the shutter is completely closed (closing in stages of a few centimetres).

In the event of unwanted opening of the shutter on closing, and immediately after the shutter has stopped:

- press section **A** of the switch until the shutter is fully open,
- release section **A** and immediately afterwards press section **B** of the switch until the shutter is fully closed (closing in stages of a few centimetres).

The safety auto-reverse function is not active during these operations.



OPENING THE BONNET

From inside: push the handle on the left-hand side under the fascia.

From outside: lift the catch and raise the bonnet.

Bonnet strut

Secure the strut to hold the bonnet open.

Before closing the bonnet, replace the strut in its housing.

To close

Lower the bonnet and release it at the end of its travel. Check that the bonnet is properly locked.

"Bonnet open" warning

With the engine running or the vehicle moving, flashing of the central **"STOP"** warning light accompanied by an audible signal and a diagram on the multi-function display, warns you that the bonnet is not properly closed.

FILLING WITH FUEL

Low fuel level



When the minimum fuel level in the tank is reached, this warning light comes on.

You can still drive approximately 30 miles (50 km).

Flashing of the warning light indicates a malfunction of the fuel gauge.

Contact a PEUGEOT dealer.

The engine must be switched off when filling with fuel.

- ☞ Open the fuel filler flap.
- ☞ Insert the key then turn it to the left.
- ☞ Remove the cap and hang it on the hook located on the inside of the flap.

A label affixed to the inside of the fuel filler flap indicates which type of fuel to use.

When you fill your tank, do not continue after the third cut-off of the pump. This could cause your vehicle to malfunction.

The capacity of the tank is approximately 60 litres.

- ☞ After filling the tank, lock the cap and close the fuel filler flap.

YOUR 307 SW IN DETAIL

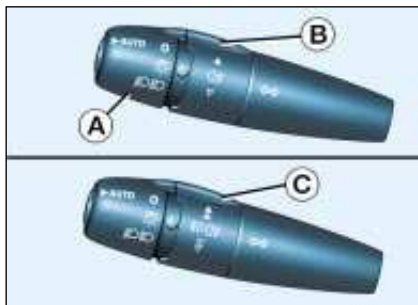

THE LIGHTS STALK

Front and rear lights

Selection is by turning ring A.



Lights off



Side lights



Dipped / main beam headlamps



Automatic switching on of lights

Dipped / Main beam change

Pull the stalk towards you.

Note: with the ignition off, when the driver's door is opened, a buzzer sounds if you have left your lights on.

Front fog lamps and rear fog lamp

Rotate the ring forwards to switch on and backwards to switch off. The status is confirmed by the indicator light on the instrument panel.

Vehicles fitted with a rear fog lamp (ring B)



Rear fog lamp

This only operates with the dipped / main beam headlamps.

Vehicles fitted with front fog lamps and a rear fog lamp (ring C)



Front fog lamps (first rotation of the ring forwards)

These operate with the side lights and the dipped headlamps.

Notes: switching on the front fog lamps switches the side lights on also.

When the main beam headlamps are switched on, the front fog lamps are switched off.

When the lights are switched off automatically, the front fog lamps and the side lights will remain on (turn the ring rearwards to switch the fog lamps off).



Front and rear fog lamps (2nd rotation of the ring forwards)

Note: to switch off the rear fog lamp and the front fog lamps, turn the ring backwards twice in succession.

"Follow-me-home" lighting

In poor light or at night, if you leave your vehicle, the side lights and dipped headlamps can be left on for approximately one minute.

To do this:

- place the key in the **STOP** position,
- place the lights stalk in position **0**,
- "flash" the headlamps,
- get out of the vehicle and lock it.

YOUR 307 SW IN DETAIL



*In good or rainy weather, both day and night, the front fog lamps and the rear fog lamp are dazzling and are prohibited.
Do not forget to switch them off when they are no longer needed.*

Direction indicators (flashers)



Left: downwards.

Right: upwards.

AUTOMATIC SWITCHING ON OF LIGHTS

The side lights and dipped beam headlamps switch on automatically if the light is poor, or during operation of the windscreen wipers. They switch off when the light becomes bright enough or the windscreen wipers stop.

Note: In foggy weather or in snow, the brightness sensor can detect sufficient light. As a consequence, the lights will not come on automatically. This function is active when the vehicle is delivered.

To disarm or activate the function:

- ☞ Turn the key to the accessories position (1st notch),
- ☞ Press the end of the lights stalk for more than four seconds.

The brightness sensor, connected to the rain sensor*, is located in the centre of the windscreen, behind the interior mirror. It is used for automatic switching on of the lights.

Operating check

Activation

Activation of this function is accompanied by an audible signal and the message **"Automatic lighting active"** on the multi-function display.

Disarming

Disarming of the function is accompanied by an audible signal.

Note: the function is disarmed temporarily when the driver uses the manual lighting controls.

If the brightness sensor does not function correctly, the system activates the function (the lights come on). The driver is alerted by an audible signal, accompanied by the message **"Automatic switching on of lights faulty"** on the multi-function display.

Contact a PEUGEOT dealer to have the system checked.

* During the year

YOUR 307 SW IN DETAIL



In good or rainy weather, both day and night, the front fog lamps and the rear fog lamp are dazzling and are prohibited. Do not forget to switch them off when they are no longer needed.

Direction indicators (flashers)



Left: downwards.

Right: upwards.

AUTOMATIC SWITCHING ON OF LIGHTS

The side lights and dipped beam headlamps switch on automatically if the light is poor, or during operation of the windscreen wipers. They switch off when the light becomes bright enough or the windscreen wipers stop.

Note: In foggy weather or in snow, the brightness sensor can detect sufficient light. As a consequence, the lights will not come on automatically. This function is active when the vehicle is delivered.

To disarm or activate the function:

- ☞ Turn the key to the accessories position (1st notch),
- ☞ Press the end of the lights stalk for more than four seconds.

The brightness sensor, connected to the rain sensor*, is located in the centre of the windscreen, behind the interior mirror. It is used for automatic switching on of the lights.

Operating check

Activation

Activation of this function is accompanied by an audible signal and the message **"Automatic lighting active"** on the multi-function display.

Disarming

Disarming of the function is accompanied by an audible signal.

Note: the function is disarmed temporarily when the driver uses the manual lighting controls.

If the brightness sensor does not function correctly, the system activates the function (the lights come on). The driver is alerted by an audible signal, accompanied by the message **"Automatic switching on of lights faulty"** on the multi-function display.

Contact a PEUGEOT dealer to have the system checked.

* During the year

YOUR 307 SW IN DETAIL

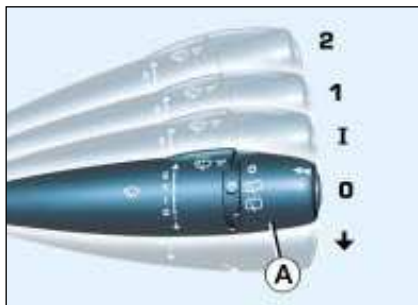

WINDSCREEN WIPER STALK

Front windscreen wiper with intermittent wiper

- 2 Fast wipe (heavy rain).
- 1 Normal wipe (moderate rain).
- I Intermittent wipe.
- 0 Off.
- ↓ Single wipe (press downwards).

In the **Intermittent** position, the wiping speed is in proportion to the vehicle speed.

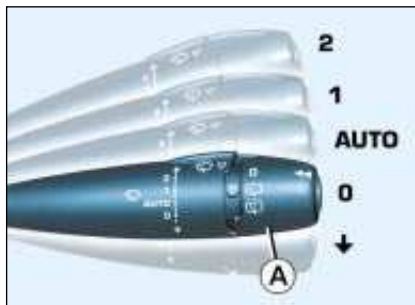

Front windscreen wiper with automatic wiper

- 2 Fast wipe (heavy rain).
- 1 Normal wipe (moderate rain).
- AUTO** Automatic wipe.
- 0 Off.
- ↓ Single wipe (press downwards).

In the **AUTO** position, the wiping speed is in proportion to the intensity of the rainfall.

After the ignition has been switched off, if the stalk was in a wipe position, you must reactivate this function:

- move the stalk to any position,
- then move it back to the required position.

Special position of the front windscreen wiper

In the minute following switching off of the ignition, any action on the stalk positions the wipers in the centre of the windscreen.

This action enables you to position the wiper blades for winter parking, cleaning or replacement (See section "Practical information - Changing a wiper blade").

To park the wipers after this has been done, switch on the ignition and operate the stalk.

Windscreen and headlamp wash

Pull the windscreen wiper stalk towards you.

The windscreen wash then the windscreen wipers operate for a fixed period.

The windscreen wash and headlamp wash operate simultaneously for two seconds, **only if the headlamps are on.**

YOUR 307 SW IN DETAIL

Automatic windscreen wipers

In the **AUTO** position, the windscreen wipers operate automatically and **adapt their speed to the intensity of the rainfall**.

Operating check

Activation

When the function is activated, the message "**Automatic windscreen wiping active**" appears on the multifunction display.

Disarming

Disarming of the function is accompanied by an audible signal.

In the event of malfunction, the driver is informed by an audible signal and the message "**Auto windscreen wiper faulty**" on the multifunction display.

In the **AUTO** position, the windscreen wiper will operate in intermittent mode.

Contact a PEUGEOT dealer to have the system checked.



Do not cover the rain sensor located on the windscreen behind the interior mirror.

When using an automatic car wash, switch off the ignition or check that the wiper stalk is not in the automatic position. In winter, it is advisable to wait for the windscreen to completely clear of ice before operating the automatic wipe.

Rear windscreen wiper



Turn ring **A** to the first notch for intermittent wiping.

Rear windscreen wash



Turn ring **A** past the first notch; the windscreen wash then the windscreen wiper operate for a fixed period.

YOUR 307 SW IN DETAIL

TRIP COMPUTER



Monochrome screen B

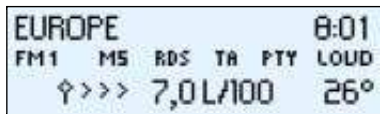

- the remaining range
- the distance travelled
- the average consumption
- the current consumption
- the average speed

In addition, it allows access to the **warning log** information and to the **Excess speed warning*** function.

Zero reset

Press the stalk for more than two seconds.

* According to destination.

Each time the button on the end of the **wash/wipe stalk** is pressed, the following sequence of data is displayed:

Monochrome screen CT

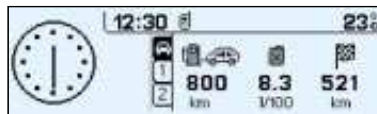

- the **"vehicle"** tab with:
 - range, current consumption and the distance still to be driven,
- tab **"1"** (route **"1"**) with:
 - the distance driven, the average consumption and the average speed calculated over route **"1"**
- tab **"2"** (route **"2"**) with the same features.

It also permits access to the **warning log** information and to the **Excess Speed Warning*** function.

Zero re-set

When the required route is displayed, press the button for more than two seconds.

Colour screen DT



- the **"Current information"** with:
 - the range,
 - the current consumption,
 - the distance still to be driven.
 - **"Route 1"** with:
 - the distance travelled,
 - the average consumption,
 - the average speed,
 - **"Route 2"** with the same features.
- It also permits access to the **warning log** information and to the **Excess Speed Warning*** function.

Zero re-set

When the required route is displayed, press the button for more than two seconds.

YOUR 307 SW IN DETAIL

Range

This shows the distance that can still be covered with the fuel remaining in the tank.

Note: this figure may increase if there is a change in the style of driving or the road surface, producing a significant drop in current consumption.

If horizontal segments are displayed for long periods instead of digits, contact a PEUGEOT dealer.

Current consumption

This is the average quantity of fuel consumed during the last few seconds.

This function is displayed only when the vehicle is travelling at a speed greater than 20 mph (30 km/h).

Average consumption

This is the average fuel consumption since the computer was last set to zero.

Distance travelled

This indicates the distance travelled since the computer was last set to zero.

Distance remaining to be travelled

This is the distance remaining to the destination. It can either be calculated by the navigation if guidance is activated, or entered by the user, minus the distance covered since the distance was entered.

Note: if digits are missing, dashes are displayed in their place.

Average speed

This is the average speed calculated since the computer was last set to zero (with the ignition on).

The warnings log

This summarises the active warning messages by displaying them on the multi-function display.

The excess speed warning function*

This monitors the maximum speed required. In the event that the programmed speed is exceeded, the message **"Speed too high"** appears on the multi-function display, accompanied by an audible signal.

Activation

Keep pressing the control until the display indicates **"Excess speed ON"**.

Programming

Press the control briefly.

Accelerate to the desired speed.

Keep pressing the control to store in memory.

Switching off

Keep pressing the control until the display indicates **"Excess speed OFF"**.

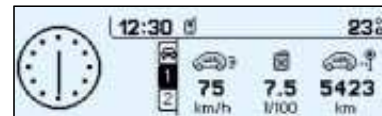

The routes

The routes "1" and "2" are independent but have identical application.

Route "1" for example allows you to make daily calculations and route "2" monthly calculations.

YOUR 307 SW IN DETAIL

TRIP COMPUTER



Monochrome screen B

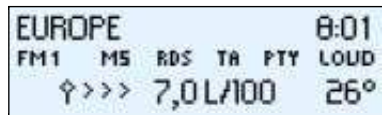

- the remaining range
- the distance travelled
- the average consumption
- the current consumption
- the average speed

In addition, it allows access to the **warning log** information and to the **Excess speed warning*** function.

Zero reset

Press the stalk for more than two seconds.

* According to destination.

Each time the button on the end of the **wash/wipe stalk** is pressed, the following sequence of data is displayed:

Monochrome screen CT

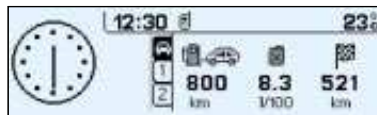

- the **"vehicle"** tab with:
 - range, current consumption and the distance still to be driven,
- tab "1" (route "1") with:
 - the distance driven, the average consumption and the average speed calculated over route "1"
- tab "2" (route "2") with the same features.

It also permits access to the **warning log** information and to the **Excess Speed Warning*** function.

Zero re-set

When the required route is displayed, press the button for more than two seconds.

Colour screen DT



- the **"Current information"** with:
 - the range,
 - the current consumption,
 - the distance still to be driven.
 - **"Route 1"** with:
 - the distance travelled,
 - the average consumption,
 - the average speed,
 - **"Route 2"** with the same features.
- It also permits access to the **warning log** information and to the **Excess Speed Warning*** function.

Zero re-set

When the required route is displayed, press the button for more than two seconds.

YOUR 307 SW IN DETAIL

Range

This shows the distance that can still be covered with the fuel remaining in the tank.

Note: this figure may increase if there is a change in the style of driving or the road surface, producing a significant drop in current consumption.

If horizontal segments are displayed for long periods instead of digits, contact a PEUGEOT dealer.

Current consumption

This is the average quantity of fuel consumed during the last few seconds.

This function is displayed only when the vehicle is travelling at a speed greater than 20 mph (30 km/h).

Average consumption

This is the average fuel consumption since the computer was last set to zero.

Distance travelled

This indicates the distance travelled since the computer was last set to zero.

Distance remaining to be travelled

This is the distance remaining to the destination. It can either be calculated by the navigation if guidance is activated, or entered by the user, minus the distance covered since the distance was entered.

Note: if digits are missing, dashes are displayed in their place.

Average speed

This is the average speed calculated since the computer was last set to zero (with the ignition on).

The warnings log

This summarises the active warning messages by displaying them on the multi-function display.

The excess speed warning function*

This monitors the maximum speed required. In the event that the programmed speed is exceeded, the message **"Speed too high"** appears on the multi-function display, accompanied by an audible signal.

Activation

Keep pressing the control until the display indicates **"Excess speed ON"**.

Programming

Press the control briefly.

Accelerate to the desired speed.

Keep pressing the control to store in memory.

Switching off

Keep pressing the control until the display indicates **"Excess speed OFF"**.

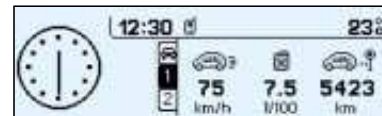

The routes

The routes "1" and "2" are independent but have identical application.

Route "1" for example allows you to make daily calculations and route "2" monthly calculations.

YOUR 307 SW IN DETAIL

Specific features of the monochrome screen CT and the colour screen DT

General menu

Press the "**MENU**" button to access the general menu.

Select the icon "**Trip computer**" using the dial, then validate to access the "Trip computer" menu.

The "trip computer" menu offers various choices:

- Trip computer configuration,
- Warnings log.

"Trip computer" context menu

The context menu associated with the "**Trip Computer**" application appears as a superimposed display when the Trip Computer is the application currently being used in the main screen window.

Briefly press the continuous application 'Trip computer' button to select one of the following functions:

- Warnings log,
- Distance to destination.

Trip computer configuration

This function allows the distance to the destination to be input (when guidance is not activated; otherwise this information is given by the navigation system) and also changing of the units of measurement (°C or °F, km and litres or miles and gallons).

Distance to destination

When guidance is not activated, this enables an approximate value to be entered to make all the trip computer calculations possible.

YOUR 307 SW IN DETAIL

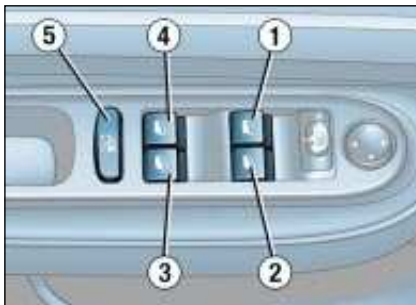

ELECTRIC WINDOWS

- 1 - Driver's electric window switch.
- 2 - Passenger's electric window switch.
- 3 - Rear right electric window switch.
- 4 - Rear left electric window switch.
- 5 - Disarming of the rear electric window switches (child lock).

You have two options:

Manual operation:

- ☞ press or pull switch **1** gently. The window stops as soon as the switch is released.

Automatic operation:

- ☞ press or pull switch **1** fully: the window opens or closes completely when the switch is released. Pressing the switch again stops the movement of the window.

Disarming the rear windows

For the safety of your children, press switch **5** to prevent operation of the rear windows irrespective of their position.

The 1st press activates the switch and the 2nd press deactivates it.

Safety auto-reverse

When the window rises and meets an obstacle, it stops and partially lowers again.

Notes:

In the event of unwanted opening of the window on closing (for example in the presence of frost), press the switch until it opens completely, then pull it immediately until it closes. Continue to hold the switch for approximately one second after the window has closed.

Following reconnection of the battery, in the event of a malfunction, release the switch and pull it again until it closes completely. Hold the switch for approximately one second after closing.

The safety auto-reverse function is not active during these operations.



Always remove the key from the ignition when leaving the vehicle, even for a short time.

In the event of contact during operation of the windows, you must reverse the movement of the window. To do this, press the switch concerned.

When the driver operates the passenger electric window switches, he must ensure that no one is preventing correct closing of the windows.

The driver must ensure that the passengers use the electric windows correctly. Be aware of children when operating the windows.

YOUR 307 SW IN DETAIL

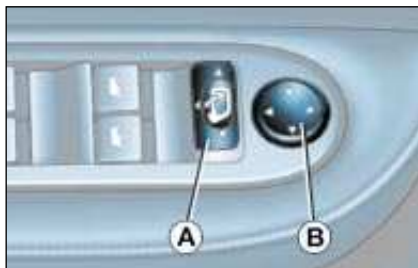

MIRRORS

Electric rear view mirrors

- ☞ Slide switch **A** to the right or to the left to select the corresponding mirror.
- ☞ Move knob **B** in all four directions to adjust.
- ☞ Return switch **A** to the centre position.

When parked, the mirrors can be folded back manually, electrically by pulling knob **A** rearwards or automatically when locking the vehicle.

The exterior mirrors are unfolded by switching on the ignition to the second notch or to the ON position.

Note: the function that controls folding of the mirrors when locking the vehicle can be disarmed. Contact a PEUGEOT dealer.



The end of the driver's mirror is aspheric (outer area indicated by a dotted line) in order to reduce the "blind spot".

Objects seen in the driver and passenger mirrors are in reality closer than they appear.

Therefore, this must be taken into account in order to correctly judge the proximity of vehicles approaching from the rear.

Manual interior mirror

The interior mirror has two positions:

- day (normal),
- night (anti-dazzle).

To change from one to the other, push or pull the lever on the lower edge of the mirror.

YOUR 307 SW IN DETAIL

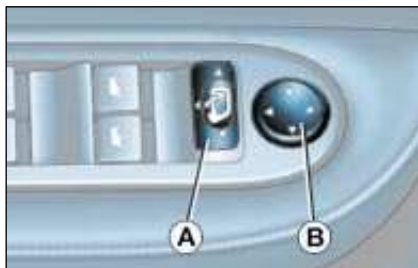

MIRRORS

Electric rear view mirrors

- ☞ Slide switch **A** to the right or to the left to select the corresponding mirror.
- ☞ Move knob **B** in all four directions to adjust.
- ☞ Return switch **A** to the centre position.

When parked, the mirrors can be folded back manually, electrically by pulling knob **A** rearwards or automatically when locking the vehicle.

The exterior mirrors are unfolded by switching on the ignition to the second notch or to the ON position.

Note: the function that controls folding of the mirrors when locking the vehicle can be disarmed. Contact a PEUGEOT dealer.



The end of the driver's mirror is aspheric (outer area indicated by a dotted line) in order to reduce the "blind spot".

Objects seen in the driver and passenger mirrors are in reality closer than they appear.

Therefore, this must be taken into account in order to correctly judge the proximity of vehicles approaching from the rear.

Manual interior mirror

The interior mirror has two positions:

- day (normal),
- night (anti-dazzle).

To change from one to the other, push or pull the lever on the lower edge of the mirror.

YOUR 307 SW IN DETAIL

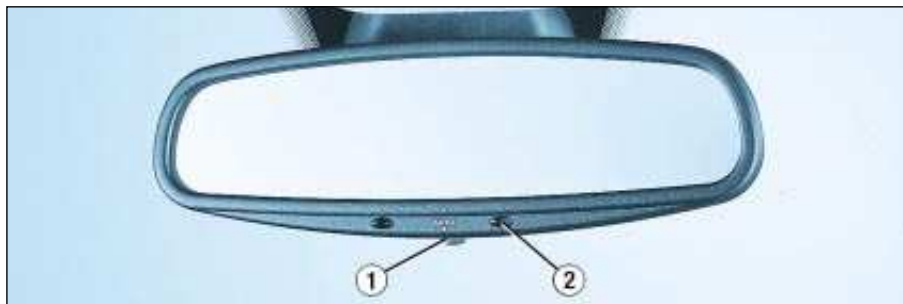

Automatic day/night interior mirror

This automatically and gradually changes between the day and night positions. To prevent dazzling, the glass of the mirror darkens automatically depending on the intensity of the light from behind. It clears as the light (headlamps of following vehicles, sunlight) decreases, ensuring maximum visibility.

Operation

Switch on the ignition and press switch 1 :

- Indicator light 2 lit (switch pressed): automatic operation.
- Indicator light 2 off: automatic system off. The mirror remains at its most clear.

Special feature

To ensure maximum visibility during manoeuvres, the mirror clears automatically when reverse gear is engaged.



AREAS FOR TOLL CARDS / CAR PARK TICKETS

The athermic windscreen has two non-reflective zones located either side of the base of the interior mirror. They are intended for affixing toll cards and/or car park tickets.



SUN VISOR WITH ILLUMINATED COURTESY MIRROR

With the ignition on, the mirror is automatically lit up when the flap is opened.

YOUR 307 SW IN DETAIL

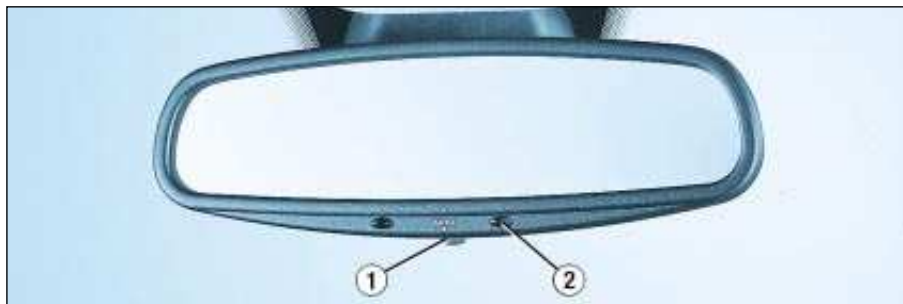

Automatic day/night interior mirror

This automatically and gradually changes between the day and night positions. To prevent dazzling, the glass of the mirror darkens automatically depending on the intensity of the light from behind. It clears as the light (headlamps of following vehicles, sunlight) decreases, ensuring maximum visibility.

Operation

Switch on the ignition and press switch 1 :

- Indicator light 2 lit (switch pressed): automatic operation.
- Indicator light 2 off: automatic system off. The mirror remains at its most clear.

Special feature

To ensure maximum visibility during manoeuvres, the mirror clears automatically when reverse gear is engaged.



AREAS FOR TOLL CARDS / CAR PARK TICKETS

The athermic windscreen has two non-reflective zones located either side of the base of the interior mirror. They are intended for affixing toll cards and/or car park tickets.



SUN VISOR WITH ILLUMINATED COURTESY MIRROR

With the ignition on, the mirror is automatically lit up when the flap is opened.

YOUR 307 SW IN DETAIL



ADJUSTING THE HEADLAMPS

Depending on the load in your vehicle, adjusting the beam of the headlamps is recommended as follows.

- 0** 1 or 2 people in the front seats.
- 3 people.
- 1** 5 or 7 people.
- 2** 5 or 7 people + maximum authorised load.
- 3** Driver + maximum authorised load.

Initial setting is position 0.

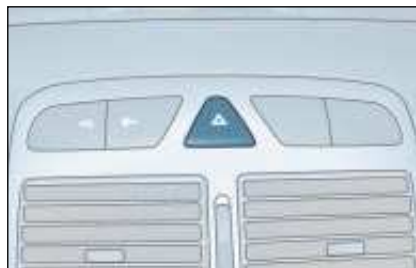

HAZARD WARNING LIGHTS

Press the button, the direction indicators flash.

They can operate with the ignition off.

Automatic lighting of hazard warning lights*

When braking in an emergency, depending on the force of deceleration, the hazard warning lights come on automatically. They switch off automatically the first time you accelerate.

It is also possible to switch them off by pressing the button.

* According to destination.

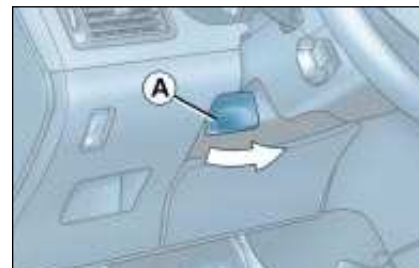

STEERING WHEEL HEIGHT AND DEPTH ADJUSTMENT

When the vehicle is stationary, unlock the steering wheel by pulling handle **A**.

Adjust the height and depth of the steering wheel, then lock it by pushing handle **A** down fully.

HORN

Press one of the spokes or the centre of the steering wheel.

YOUR 307 SW IN DETAIL

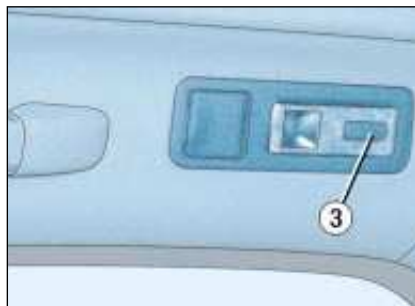

COURTESY LIGHTS

- 1 - Front courtesy light
- 2 - Front map reading lights
- 3 - 2nd row rear reading lights
- 4 - 3rd row rear courtesy light

With the key in the accessories position (1st notch) or with the ignition on, operate the relevant switch.

The front and rear courtesy lights come on when the ignition key is removed, on unlocking the vehicle or on opening one of the doors.

They gradually go off after the ignition has been switched on or the vehicle is locked.

In addition, when the vehicle is moving, the front and rear courtesy lights flash if a door or the tailgate is not closed properly.

- ☞ Pressing switch **1** turns on the front and rear courtesy lights for a duration of ten minutes.
- ☞ Pressing switch **3** or **4** turns on the reading light concerned or the rear courtesy light for a duration of ten minutes.

Note: The courtesy lights can be deactivated by pressing switch **1** for more than three seconds. However, a short press on switch **1** switches the front courtesy light on and off.

The map reading lights are not affected by this and may be switched on.

- ☞ To re-activate the lights, press the switch for more than three seconds.

YOUR 307 SW IN DETAIL

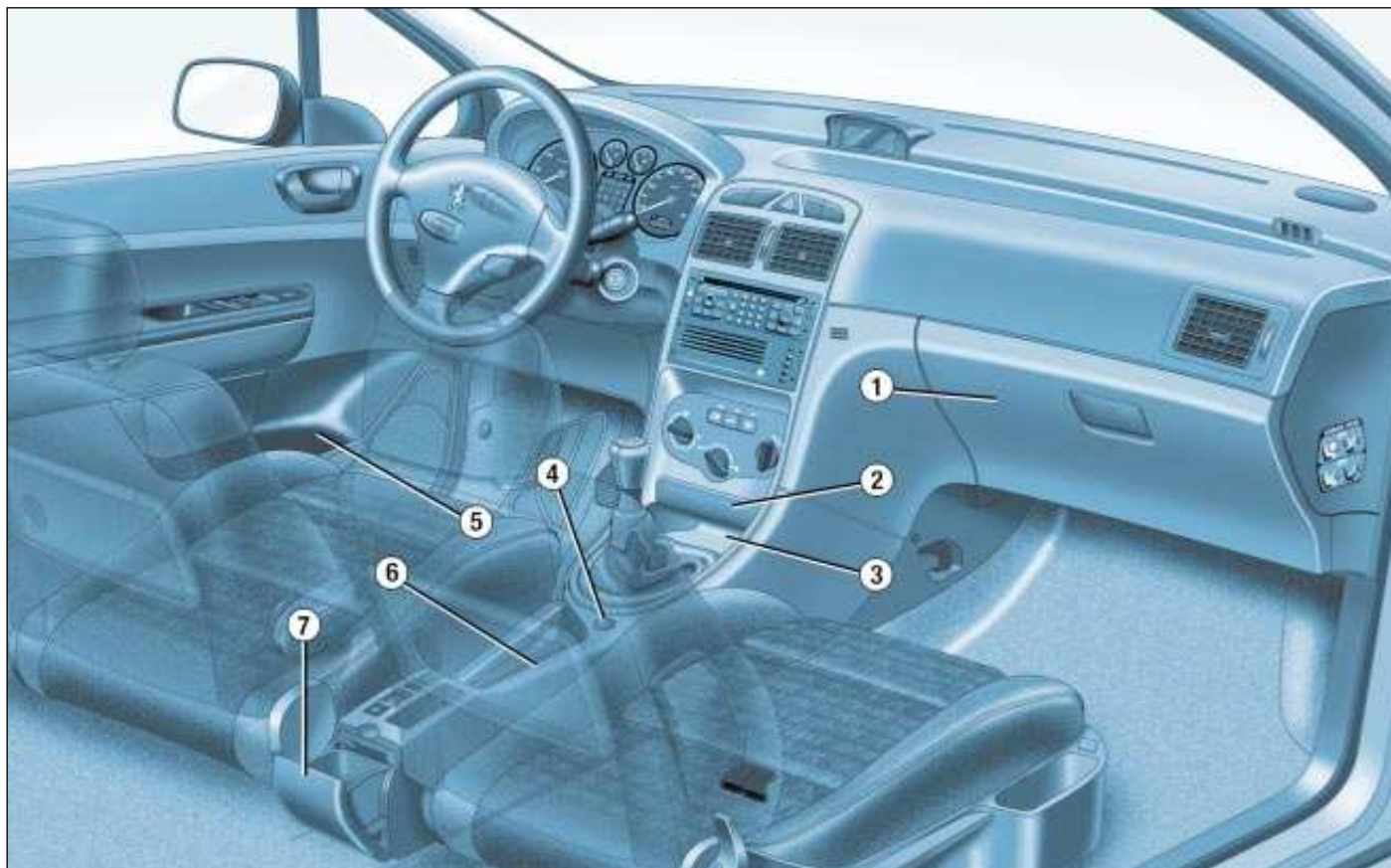

YOUR 307 SW IN DETAIL

INTERIOR LAYOUT

1. **Glove box**

This is fitted with a lock.

To open the glove box, lift the handle.

The glove box lights when the lid is opened.

It contains a ventilation nozzle that can be closed, distributing the same conditioned air as the vents of the passenger compartment, and three sockets for connecting video equipment.

The layout allows storage of a water bottle, a pen, the vehicle handbook, a pair of spectacles, tokens etc.

2. **Front ashtray**

Pull the lid to open the ashtray.

To empty it after opening, press the tab and extract the ashtray.

3. **Storage**

4. **12 volt accessories socket**

This is a lighter type socket, fitted with a cap. It is supplied with current from the accessories position (1st notch).

5. **Door tray**

6. **Storage/Can holder**

7. **Waste container**

To empty, open it fully (past the point of resistance) then pull on the receptacle to remove it.

To refit, lock it in place on the cover.

YOUR 307 SW IN DETAIL

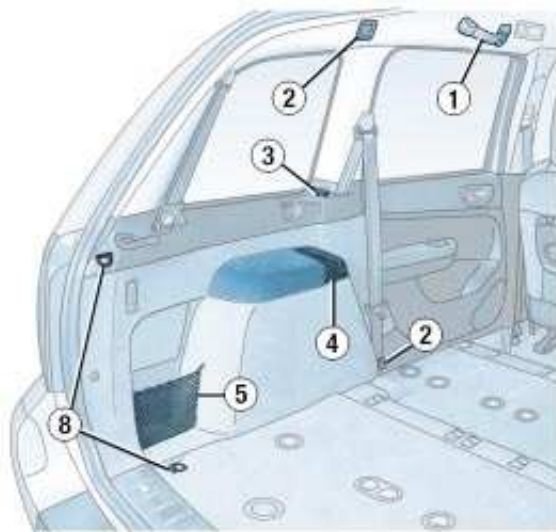

YOUR 307 SW IN DETAIL

BOOT LAYOUT

1. Grab handles and coat hooks

2. High load retaining net fastenings

The high load retaining net can be fitted in the 2nd or 3rd row.

Open the covers of the corresponding upper fastenings.

Fit the ends of the metal bar in these fastenings.

Secure the two opaque material strap hooks in the stowing rings on the floor.

The rings are located directly below the corresponding upper fastenings.

Pull the two straps taut.

Secure the two hooks on the elastic parts of the opaque material in these rings.

Note: the net must be positioned so that the label can be seen from the boot. This ensures that the central seat belt is routed correctly.

3. 12V Socket for accessories

This is a 12 volt socket (lighter type), installed on the load space cover left support.

It is supplied with the ignition off.

4. Rear armrests with grab handle

5. Storage nets

One of them contains the luggage retaining net.

6. Load space cover

To install it:

- position one end of the cover roller in the 2nd row,

- compress the opposite end of the roller and position it,
- release it to allow it to engage,
- unroll the cover as far as the boot pillars,
- insert the cover guides in the rails in the pillars,

To remove it:

- remove the cover guides from the pillar rails,
- return the cover into its roller,
- compress it and remove it from its support at the 2nd row,

To store it, pull it back and place it with the two storage nets, already lowered.

Note: the roller has two hooks for securing the luggage retaining net depending on where it is installed.

7. Luggage retaining net

Secure the net's seven hooks in the stowing rings and the fastenings on the floor.

8. Luggage retaining net fastenings ("hammock" version) in the tailgate

Fold the net in two.

Secure the two centre hooks in the stowing rings on the floor.

Secure the net's remaining four hooks on the boot pillars.

See configuration of the nets (next page)

YOUR 307 SW IN DETAIL

.....

Example of installation of the nets:

Luggage retaining net, "folded" version



Luggage retaining net, "hammock" version in the tailgate



High load retaining net in the 2nd row



Luggage retaining net, "L" version



Luggage retaining net, "hammock" version at the roller



Load space cover stored with the two storage nets



YOUR 307 SW IN DETAIL

"PORSCHE TIPTRONIC SYSTEM" AUTOMATIC GEARBOX

The four speed **automatic** gearbox offers a choice between the comfort of **integral automatic operation**, enhanced by a **sport** and a **snow** programme, or the pleasure of **manual gear changing**.

Gear selection gate

☞ Move the lever in the gate to select a function.

Once the function is selected, the corresponding indicator light appears on the instrument panel display.



S : sport programme.

❄ : snow programme.

Park: to **immobilise** the vehicle or **start the engine**, with the handbrake on or off.

Reverse: to **reverse** (select this function with the vehicle stationary, engine at idle).

Neutral: to **start the engine** and to **park**, with the handbrake on.

Note: if function **N** is engaged inadvertently while driving, allow the engine to return to idle before engaging function **D** to accelerate.

Drive : for **driving** in automatic mode.

Manual: for **driving** in manual mode.

Moving off

With the engine running, to move off from position **P**:

- ☞ **it is essential to press the brake pedal to exit position P,**
- ☞ select function **R, D** or **M**, then gradually release the pressure on the brake pedal; the vehicle moves off immediately.

You can also move off from position **N**:

- ☞ release the handbrake, with your foot on the brake,
- ☞ select function **R, D** or **M**, then gradually release the pressure on the brake pedal; the vehicle moves off immediately.

WARNING

When the engine is at idle, brakes not applied, if function **R, D** or **M** is selected the vehicle moves even without the accelerator being pressed. For this reason, **do not leave children unsupervised inside the vehicle, with the engine running.**

When maintenance operations need to be carried out with the engine running, carry the handbrake and select position **P**.

YOUR 307 SW IN DETAIL

Automatic operation

Automatic changing of the **four gears**:

☞ select function **D** in the gate.

The gearbox always selects the most suitable gear according to the following parameters:

- the style of driving,
- the road profile,
- the vehicle load.

The gearbox is then operating in auto-adaptive mode, without any action on your part.

WARNING

Never select function **N** when the vehicle is moving.

Never select functions **P** or **R** unless the vehicle is stationary.

Never change between functions to optimise braking on a slippery surface.

Notes

For immediate maximum acceleration without touching the gear lever, press the accelerator pedal down as far as it will go (kickdown). The gearbox will automatically change down or maintain the gear selected until maximum engine speed is reached.

When braking, the gearbox will automatically change down in order to provide efficient engine braking.

If you take your foot off the accelerator suddenly, the gearbox will not change to a higher gear for reasons of safety.

Sport and snow programme

In addition to the auto-adaptive programme, there are two special programmes.

The programme is displayed on the instrument panel screen.

Sport programme

☞ Press button **S** once the vehicle has been started and function **D** selected.

The gearbox automatically favours sporty driving and more dynamic acceleration.

Snow programme

This programme improves starting and drive when traction is poor.

☞ Press button **❄** once the vehicle has been started and function **D** selected.

The gearbox adapts to driving on slippery roads.

Note: you can return to the auto-adaptive programme at any time.

☞ Press button **S** or **❄** again to switch off the programme you are in.

Manual operation

Manual changing of the **four gears**:

☞ select function **M** in the gate,

☞ push the lever to the **+** sign to change to a higher gear,

☞ pull the lever to the **-** sign to change to a lower gear.

You can change from position **D** (driving in automatic mode) to position **M** (driving in manual mode) at any time.

Note

Note

It is only possible to change from one gear to another if the vehicle speed and engine speed permit. If they do not, the vehicle will operate temporarily in automatic mode.

When the vehicle is stationary or moving very slowly, the gearbox automatically selects gear **M1**.

Programme **S** (sport) and **❄** (snow) do not operate in manual mode.

YOUR 307 SW IN DETAIL

Operating abnormality

Any operating abnormality is indicated by an audible signal, accompanied by the message "**Automatic gearbox faulty**" on the multi-function display and flashing of the Sport and Snow warning lights on the instrument panel.

In this situation the gearbox operates in downgrade mode (locked in 3rd gear). You may feel a substantial knock when changing from **P** to **R** and from **N** to **R** (this will not cause any damage to the gearbox).

Do not exceed 60 mph (100 km/h), keeping within the limit of local speed restrictions.

Contact a PEUGEOT dealer as soon as possible.



*If the battery is flat and the lever is in position **P**, it will be impossible to change to another position.*

HANDBRAKE

Locking

Pull the handbrake to immobilise your vehicle.

Warning: when parking on a slope, direct your wheels towards the pavement and pull the handbrake.

Unlocking

Pull on the handle and press the button to release the handbrake.



Illumination of this warning light and of the **STOP** warning light, accompanied by an audible signal (while the vehicle is being driven) and the message "**handbrake on**" on the multi-function display, indicates that the handbrake is still on or has not been properly released.

ANTI-LOCK BRAKING SYSTEM (ABS) AND THE ELECTRONIC BRAKE FORCE DISTRIBUTION (EBFD)

The ABS, in conjunction with the electronic brake force distribution, increases the stability and manoeuvrability of your vehicle, particularly on poor or slippery road surfaces.

Note: when changing wheels (tyres and rims), make sure that these are approved.

The anti-lock braking system comes into operation automatically when there is a risk of wheel lock.



When this warning light comes on, accompanied by a buzzer and the message "**ABS fault**", it indicates that there is a malfunction of the ABS, which can cause a loss of control of the vehicle when braking.



When this warning light comes on, connected to the **STOP** and **ABS** warning lights, accompanied by a buzzer and the message "**Braking fault**", it indicates that there is a malfunction of the electronic brake force distribution, which can cause a loss of control of the vehicle when braking.

YOUR 307 SW IN DETAIL

Operating abnormality

Any operating abnormality is indicated by an audible signal, accompanied by the message "**Automatic gearbox faulty**" on the multi-function display and flashing of the Sport and Snow warning lights on the instrument panel.

In this situation the gearbox operates in downgrade mode (locked in 3rd gear). You may feel a substantial knock when changing from **P** to **R** and from **N** to **R** (this will not cause any damage to the gearbox).

Do not exceed 60 mph (100 km/h), keeping within the limit of local speed restrictions.

Contact a PEUGEOT dealer as soon as possible.



*If the battery is flat and the lever is in position **P**, it will be impossible to change to another position.*

HANDBRAKE

Locking

Pull the handbrake to immobilise your vehicle.

Warning: when parking on a slope, direct your wheels towards the pavement and pull the handbrake.

Unlocking

Pull on the handle and press the button to release the handbrake.



Illumination of this warning light and of the **STOP** warning light, accompanied by an audible signal (while the vehicle is being driven) and the message "**handbrake on**" on the multi-function display, indicates that the handbrake is still on or has not been properly released.

ANTI-LOCK BRAKING SYSTEM (ABS) AND THE ELECTRONIC BRAKE FORCE DISTRIBUTION (EBFD)

The ABS, in conjunction with the electronic brake force distribution, increases the stability and manoeuvrability of your vehicle, particularly on poor or slippery road surfaces.

Note: when changing wheels (tyres and rims), make sure that these are approved.

The anti-lock braking system comes into operation automatically when there is a risk of wheel lock.



When this warning light comes on, accompanied by a buzzer and the message "**ABS fault**", it indicates that there is a malfunction of the ABS, which can cause a loss of control of the vehicle when braking.



When this warning light comes on, connected to the **STOP** and **ABS** warning lights, accompanied by a buzzer and the message "**Braking fault**", it indicates that there is a malfunction of the electronic brake force distribution, which can cause a loss of control of the vehicle when braking.

YOUR 307 SW IN DETAIL

Operating abnormality

Any operating abnormality is indicated by an audible signal, accompanied by the message "**Automatic gearbox faulty**" on the multi-function display and flashing of the Sport and Snow warning lights on the instrument panel.

In this situation the gearbox operates in downgrade mode (locked in 3rd gear). You may feel a substantial knock when changing from **P** to **R** and from **N** to **R** (this will not cause any damage to the gearbox).

Do not exceed 60 mph (100 km/h), keeping within the limit of local speed restrictions.

Contact a PEUGEOT dealer as soon as possible.



*If the battery is flat and the lever is in position **P**, it will be impossible to change to another position.*

HANDBRAKE

Locking

Pull the handbrake to immobilise your vehicle.

Warning: when parking on a slope, direct your wheels towards the pavement and pull the handbrake.

Unlocking

Pull on the handle and press the button to release the handbrake.



Illumination of this warning light and of the **STOP** warning light, accompanied by an audible signal (while the vehicle is being driven) and the message "**handbrake on**" on the multi-function display, indicates that the handbrake is still on or has not been properly released.

ANTI-LOCK BRAKING SYSTEM (ABS) AND THE ELECTRONIC BRAKE FORCE DISTRIBUTION (EBFD)

The ABS, in conjunction with the electronic brake force distribution, increases the stability and manoeuvrability of your vehicle, particularly on poor or slippery road surfaces.

Note: when changing wheels (tyres and rims), make sure that these are approved.

The anti-lock braking system comes into operation automatically when there is a risk of wheel lock.



When this warning light comes on, accompanied by a buzzer and the message "**ABS fault**", it indicates that there is a malfunction of the ABS, which can cause a loss of control of the vehicle when braking.



When this warning light comes on, connected to the **STOP** and **ABS** warning lights, accompanied by a buzzer and the message "**Braking fault**", it indicates that there is a malfunction of the electronic brake force distribution, which can cause a loss of control of the vehicle when braking.

YOUR 307 SW IN DETAIL

Stop immediately.

In both cases, consult a Peugeot dealer.

Normal operation of the ABS may make itself felt by slight vibrations of the brake pedal.

In emergency braking, press very firmly without releasing the pressure.

EMERGENCY BRAKING ASSISTANCE SYSTEM

In an emergency, this system enables the optimum braking pressure to be reached more quickly, thus reducing the stopping distance.

It is triggered according to the speed of activation of the brake pedal. The effect of this is a reduction in the resistance of the pedal and an increase in braking efficiency.

TRACTION CONTROL (ASR) AND DYNAMIC STABILITY CONTROL (ESP)

These systems are linked and complement the ABS.

The ASR system optimises drive to prevent the wheels skidding, by acting on the brakes of the drive wheels and on the engine. It also allows the directional stability of the vehicle to be improved on acceleration.

If there is a variation between the trajectory followed by the vehicle and that required by the driver, the ESP system automatically acts on the engine and the brake of one or more wheels, in order to put the vehicle back on course

Operating check



When a malfunction of the system occurs, the indicator light comes on, accompanied by an audible signal and the message

"ESP/ASR not operational" on the multi-function display.

Contact a PEUGEOT dealer to have the system checked.



The ESP system offers increased safety during normal driving, but should not incite the driver to take risks or to drive at high speed.

The operation of the system is ensured to the extent to which the recommendations of the manufacturer regarding the wheels (tyres and wheel rims), the braking components, the electronic components and the assembly and repair procedures within the PEUGEOT network are observed.

After an impact, have the system checked by a PEUGEOT dealer.

YOUR 307 SW IN DETAIL

Stop immediately.

In both cases, consult a Peugeot dealer.

Normal operation of the ABS may make itself felt by slight vibrations of the brake pedal.

In emergency braking, press very firmly without releasing the pressure.

EMERGENCY BRAKING ASSISTANCE SYSTEM

In an emergency, this system enables the optimum braking pressure to be reached more quickly, thus reducing the stopping distance.

It is triggered according to the speed of activation of the brake pedal. The effect of this is a reduction in the resistance of the pedal and an increase in braking efficiency.

TRACTION CONTROL (ASR) AND DYNAMIC STABILITY CONTROL (ESP)

These systems are linked and complement the ABS.

The ASR system optimises drive to prevent the wheels skidding, by acting on the brakes of the drive wheels and on the engine. It also allows the directional stability of the vehicle to be improved on acceleration.

If there is a variation between the trajectory followed by the vehicle and that required by the driver, the ESP system automatically acts on the engine and the brake of one or more wheels, in order to put the vehicle back on course

Operating check



When a malfunction of the system occurs, the indicator light comes on, accompanied by an audible signal and the message

"ESP/ASR not operational" on the multi-function display.

Contact a PEUGEOT dealer to have the system checked.



The ESP system offers increased safety during normal driving, but should not incite the driver to take risks or to drive at high speed.

The operation of the system is ensured to the extent to which the recommendations of the manufacturer regarding the wheels (tyres and wheel rims), the braking components, the electronic components and the assembly and repair procedures within the PEUGEOT network are observed.

After an impact, have the system checked by a PEUGEOT dealer.

YOUR 307 SW IN DETAIL



CRUISE CONTROL

Cruise control enables the vehicle to maintain a steady speed programmed by the driver, regardless of the road characteristics and without the driver having to touch the accelerator or brake pedals.

In order for it to be memorised, the vehicle speed must be greater than 25 mph (40 km/h) or 40 mph (60 km/h), depending on the engine, and fourth gear at least must be engaged (second gear for the automatic gearbox).

Operation

- ☞ Place switch **1** in the **ON** position. A speed can be memorised.
- ☞ Place switch **1** in the **OFF** position to cancel.

Memorising a speed

As soon as you reach the chosen speed, press button **2** or **3**.

This memorises the speed, which will be maintained automatically.

Note: It is possible to accelerate and drive momentarily at a speed greater than the memorised speed. When the accelerator pedal is released, the vehicle will return to the memorised speed.

Cancelling the memorised speed

If you wish to cancel the memorised speed:

- ☞ Press button **4** or the brake or clutch pedal.

Recalling the memorised speed

After cancellation, press button **4**. Your vehicle will return to the last memorised speed.

Changing a memorised speed

To memorise a speed higher than the previous one:

- ☞ press button **3**;
- ☞ release it when you have reached the required speed.

To memorise a speed lower than the previous one:

- ☞ press button **2**;
- ☞ release it when you have reached the required speed.

Cancelling the cruise control

- ☞ Place switch **1** in the **OFF** position or switch off the ignition.



Do not use cruise control on slippery roads or in heavy traffic.

YOUR 307 SW IN DETAIL

REAR PARKING ASSISTANCE

This system consists of four proximity sensors, located in the rear bumper, and a special speaker.

This detects any obstacle (person, vehicle, tree, gate, etc.) behind the vehicle. Nevertheless, it cannot detect obstacles located just below the bumper.

An object, such as a stake, a road-works cone or any other similar object may be detected at the beginning of the manoeuvre, but may no longer be detected when the vehicle comes close to it.

Note: this function will be disarmed automatically when the vehicle is towing a trailer or when a bicycle carrier is fitted (vehicle fitted with towing attachment or bicycle carrier recommended by PEUGEOT).

In bad or wintry weather, ensure that the sensors are not covered with mud, frost or snow.

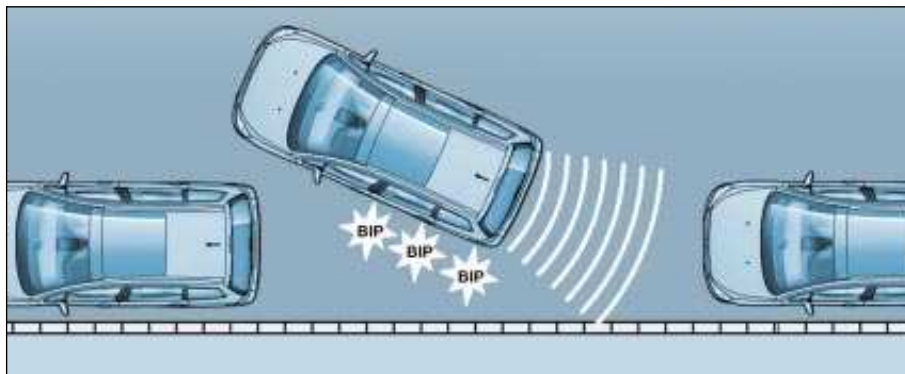

Detection zone

Activation

The system is activated as soon as reverse gear is engaged; an audible bleep shows that it is active.

The proximity information is given by an audible signal, which becomes more rapid as the vehicle approaches the obstacle.

When the distance between the rear of the vehicle and the obstacle is less than approximately twenty-five centimetres, the audible signal becomes continuous.

Deactivation

☞ Change to neutral, the system is again inactive.



If there is an operating fault, the audible signal will be a short bleep followed by a long bleep when changing to reverse gear.

YOUR 307 SW IN DETAIL

AIR BAGS

The air bags have been designed to maximise the safety of the occupants in the event of serious collisions. They work in conjunction with the force-limiting seat belts.

The electronic detectors register and analyse any abrupt deceleration of the vehicle: if the triggering threshold is reached, the air bags inflate instantly and protect the occupants of the vehicle.

Immediately after the impact, the air bags deflate rapidly so that they do not hinder the visibility of the occupants nor their exit if necessary from the vehicle.

The air bags are not deployed in the case of collisions which are not serious, for which the seat belt is sufficient to ensure maximum protection. The seriousness of a collision depends on the nature of the obstacle and the speed of the vehicle at the moment of the collision.

Air bags only operate when the ignition is switched on.

Note: the gas escaping from the air bag can be a minor irritant.



FRONT AIR BAGS

These are folded in the centre of the steering wheel for the driver and in the fascia for the front passenger. They are deployed simultaneously, except in cases where the passenger air bag is disarmed.

Front air bag fault



If this warning light comes on, accompanied by an audible signal and the message "Air bag fault" on the multifunction display, contact a PEUGEOT dealer to have the system checked.



Disarming the passenger air bag*

To ensure the safety of your child, it is essential to disarm the passenger air bag when you install a rear-facing child seat on the front passenger seat.

☞ With the ignition switched off, insert the key into the passenger air bag disarming switch 1, turn it to the "OFF" position, then remove the key keeping the slot in this position.

The air bag warning light on the instrument panel is lit throughout the disarming process.

* According to destination.

YOUR 307 SW IN DETAIL

In the "OFF" position, the passenger air bag will not be triggered in the event of an impact.

As soon as the child seat is removed, turn the air bag slot to the "ON" position to re-activate the air bag and thus ensure the safety of your passenger in the event of an impact.

Operating check

This is confirmed by an indicator light, accompanied by an audible signal and a message on the multi-function display.



With the ignition on (2nd notch), illumination of this warning light accompanied by an audible signal and the message "**Passenger air bag disarmed**" on the multifunction display, indicates that the passenger air bag is disarmed (switch in the "OFF" position).

SIDE AIR BAGS* AND CURTAIN AIR BAGS*

The side air bags are incorporated into the front seat backs on the door side.

The curtain air bags are incorporated into the door pillars and the upper part of the passenger compartment.

They are deployed independently of each other depending on which side the collision occurs.

Operating check

This is confirmed by an indicator light, accompanied by an audible signal and a message on the multi-function display.



If this indicator light comes on, accompanied by an audible signal and the message "**Air bag fault**" on the multi-function display, contact a PEUGEOT dealer to have the system checked.



If the two "Air bag fault" and "Passenger air bag disarmed" warning lights come on permanently, do not install a rearward facing child seat and consult a PEUGEOT dealer.

* According to destination.

YOUR 307 SW IN DETAIL



For the front, side and curtain* air bags to be fully effective, observe the following safety rules:*

- *Wear a correctly adjusted seat belt.*
- *Sit in a normal upright position.*
- *Do not leave anything between the occupants of the front seats and the air bags (a child, pet, object). This could hamper the operation of the air bags or injure the occupants.*
- *All work on the air bag system is strictly forbidden unless it is carried out by qualified personnel of the PEUGEOT network.*
- *After an accident or if the vehicle has been stolen or broken into, have the air bag systems checked.*
- *The air bag systems have been designed to be fully operational for 10 years after the vehicle has been registered. For greater safety, have them checked by a PEUGEOT dealer within 10 years following the purchase of the vehicle.*

Front air bags

- *Do not drive holding the steering wheel by its spokes or resting your hands on the centre part of the wheel.*
- *Passengers must not place their feet on the fascia*
- *Smoke as little as possible; deployment of the air bags can cause burns or the risk of injury from a cigarette or pipe.*
- *Never remove or pierce the steering wheel or hit it violently.*

Side air bags*

- *Only put approved covers on the front seats. Contact your PEUGEOT dealer.*
- *Do not fix or glue anything to the front seat backs. This could cause injury to the chest or arms when the side air bag inflates.*
- *Do not sit with the upper part of the body any nearer to the door than necessary.*

Curtain air bags*

- *Do not fix or glue anything to the pillars or the roof. This could cause injury to the head when the curtain air bag inflates.*
Do not remove the bolts from the grab handles installed on the roof, they play a part in securing the curtain air bags.

** According to destination.*

YOUR 307 SW IN DETAIL

In the "OFF" position, the passenger air bag will not be triggered in the event of an impact.

As soon as the child seat is removed, turn the air bag slot to the "ON" position to re-activate the air bag and thus ensure the safety of your passenger in the event of an impact.

Operating check

This is confirmed by an indicator light, accompanied by an audible signal and a message on the multi-function display.



With the ignition on (2nd notch), illumination of this warning light accompanied by an audible signal and the message "**Passenger air bag disarmed**" on the multifunction display, indicates that the passenger air bag is disarmed (switch in the "OFF" position).

SIDE AIR BAGS* AND CURTAIN AIR BAGS*

The side air bags are incorporated into the front seat backs on the door side.

The curtain air bags are incorporated into the door pillars and the upper part of the passenger compartment.

They are deployed independently of each other depending on which side the collision occurs.

Operating check

This is confirmed by an indicator light, accompanied by an audible signal and a message on the multi-function display.



If this indicator light comes on, accompanied by an audible signal and the message "**Air bag fault**" on the multi-function display, contact a PEUGEOT dealer to have the system checked.



If the two "Air bag fault" and "Passenger air bag disarmed" warning lights come on permanently, do not install a rearward facing child seat and consult a PEUGEOT dealer.

* According to destination.

YOUR 307 SW IN DETAIL



For the front, side and curtain* air bags to be fully effective, observe the following safety rules:*

- *Wear a correctly adjusted seat belt.*
- *Sit in a normal upright position.*
- *Do not leave anything between the occupants of the front seats and the air bags (a child, pet, object). This could hamper the operation of the air bags or injure the occupants.*
- *All work on the air bag system is strictly forbidden unless it is carried out by qualified personnel of the PEUGEOT network.*
- *After an accident or if the vehicle has been stolen or broken into, have the air bag systems checked.*
- *The air bag systems have been designed to be fully operational for 10 years after the vehicle has been registered. For greater safety, have them checked by a PEUGEOT dealer within 10 years following the purchase of the vehicle.*

Front air bags

- *Do not drive holding the steering wheel by its spokes or resting your hands on the centre part of the wheel.*
- *Passengers must not place their feet on the fascia*
- *Smoke as little as possible; deployment of the air bags can cause burns or the risk of injury from a cigarette or pipe.*
- *Never remove or pierce the steering wheel or hit it violently.*

Side air bags*

- *Only put approved covers on the front seats. Contact your PEUGEOT dealer.*
- *Do not fix or glue anything to the front seat backs. This could cause injury to the chest or arms when the side air bag inflates.*
- *Do not sit with the upper part of the body any nearer to the door than necessary.*

Curtain air bags*

- *Do not fix or glue anything to the pillars or the roof. This could cause injury to the head when the curtain air bag inflates.*
Do not remove the bolts from the grab handles installed on the roof, they play a part in securing the curtain air bags.

** According to destination.*

PRACTICAL INFORMATION

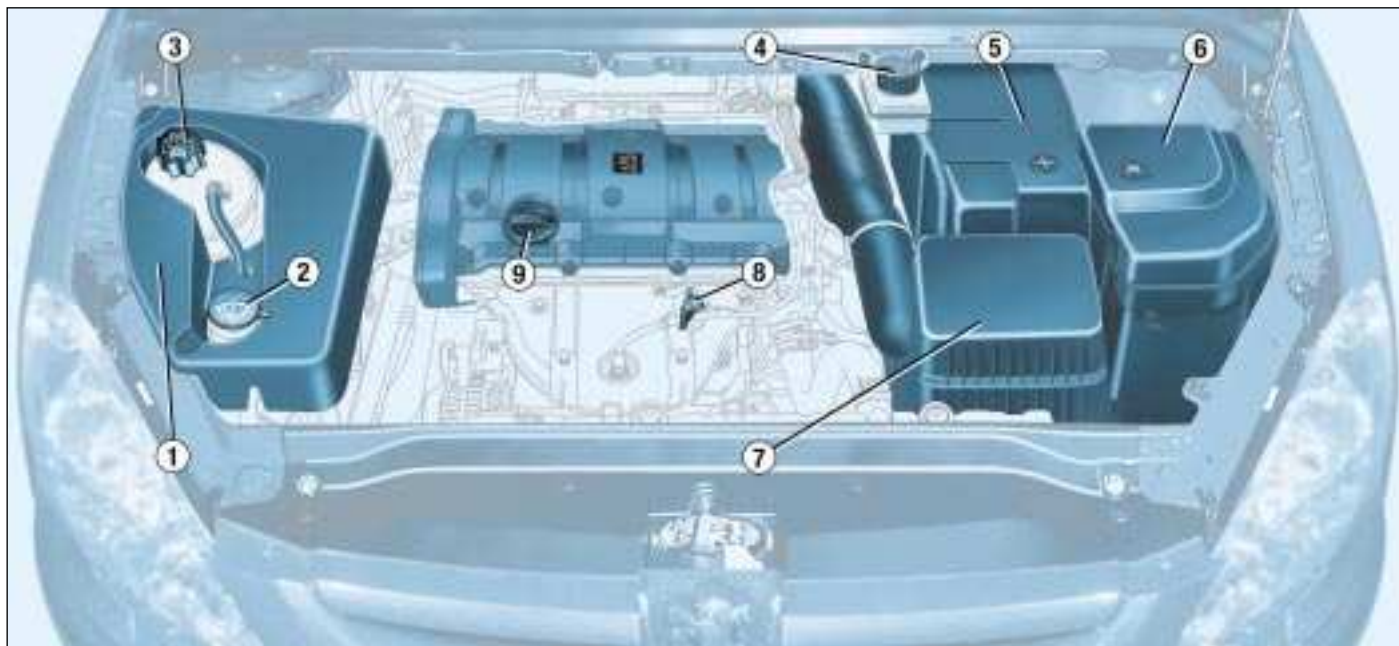

1.6 LITRE 16V PETROL ENGINE

1 - Power steering reservoir.

2 - Windscreen/headlamp* wash reservoir.

3 - Coolant reservoir.

4 - Brake fluid reservoir.

5 - Battery.

6 - Fuse box.

7 - Air filter.

8 - Dipstick.

9 - Engine oil reservoir.

* According to destination.

PRACTICAL INFORMATION

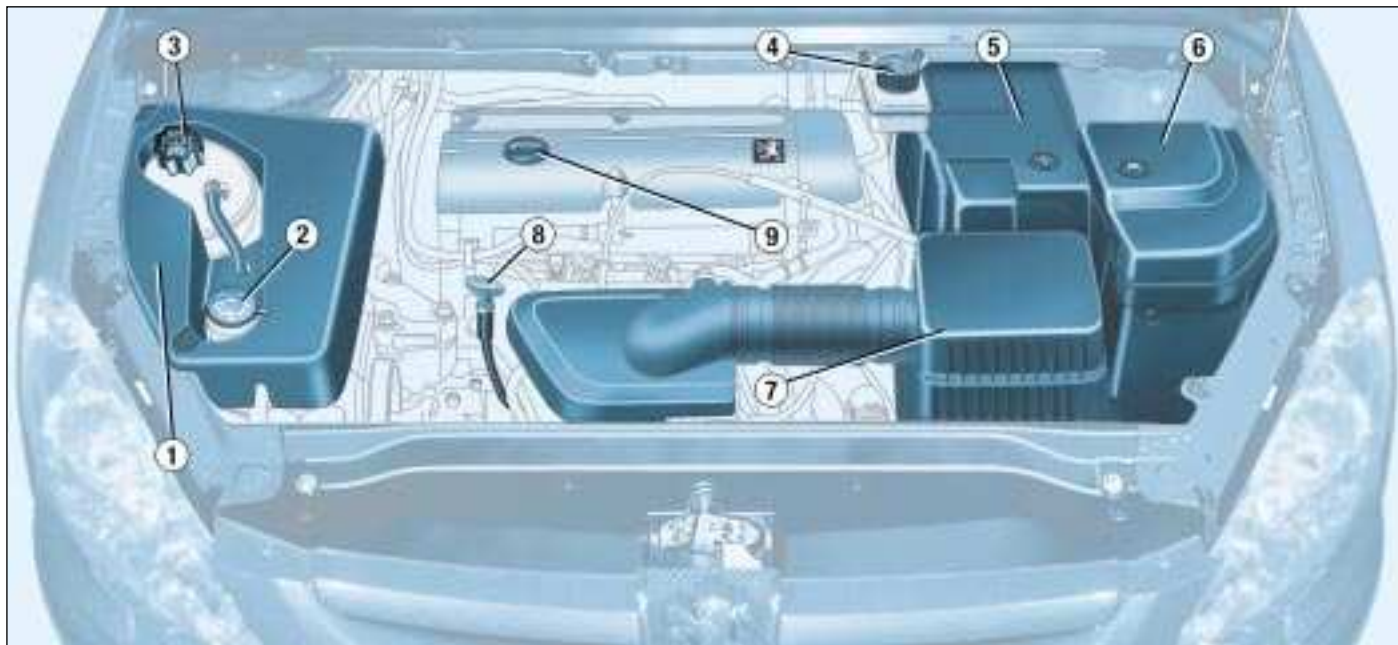

2 LITRE 16V PETROL ENGINE

1 - Power steering reservoir.

2 - Windscreen/headlamp* wash reservoir.

3 - Coolant reservoir.

4 - Brake fluid reservoir.

5 - Battery.

6 - Fuse box.

7 - Air filter.

8 - Dipstick.

9 - Engine oil reservoir.

* According to destination.

PRACTICAL INFORMATION

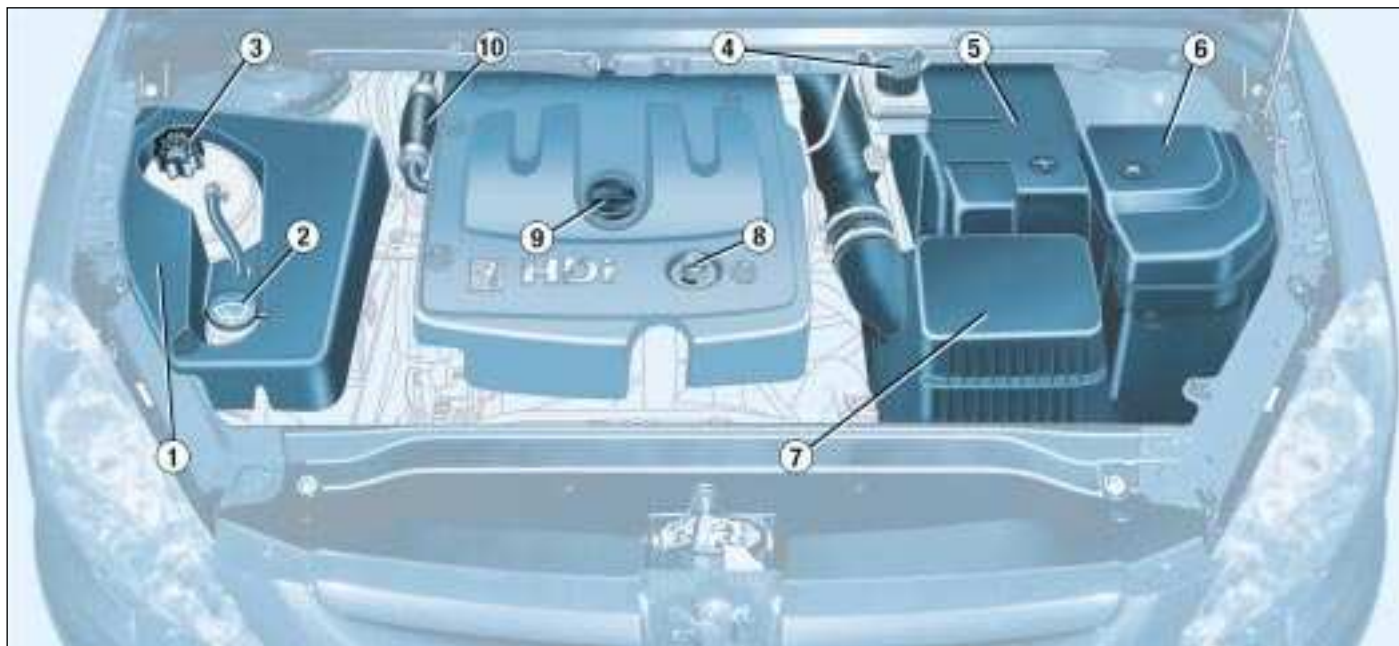

2 LITRE TURBO DIESEL HDI ENGINE (90 bhp/110 bhp)

1 - Power steering reservoir.

2 - Windscreen/headlamp* wash reservoir.

3 - Coolant reservoir.

4 - Brake fluid reservoir.

5 - Battery.

6 - Fuse box.

7 - Air filter.

8 - Dipstick.

9 - Engine oil reservoir.

10- Priming pump.

* According to destination.

PRACTICAL INFORMATION

CHECKING THE LEVELS

Oil level

☞ Check the level regularly and top up between changes. The maximum consumption is 0.5 l per 600 miles (1000 km).

Check the level with the vehicle level, engine cold, using the oil level gauge on the instrument panel or the dipstick.

Dipstick

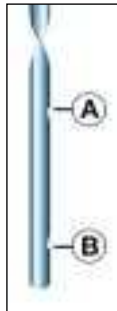

There are two marks on the dipstick:

A = maximum

Never fill past this mark.

B = minimum

To maintain the reliability of engines and emission control systems, the use of additives in engine oil is prohibited.

Oil change

According to the information given in "PEUGEOT SERVICING".

Note: avoid used oil coming into prolonged contact with the skin.

Viscosity selection

In all cases, the oil selected must meet the manufacturer's requirements.

Brake fluid level:

- The level must always be between the DANGER and MAXIMUM marks in the reservoir.
- If the level drops substantially, contact a PEUGEOT dealer immediately.

Fluid change:

- must be carried out according to the manufacturer's servicing schedule.
- use fluids recommended by the manufacturer, which fulfil DOT4 standards.

Note: brake fluid is harmful to health and very corrosive. Avoid all contact with the skin.

Cooling system

Use the fluid recommended by the manufacturer.

When the engine is warm, the temperature of the coolant is controlled by the engine fan. As this fan can operate with the ignition key removed and because the cooling system is pressurised, wait for at least one hour after the engine has stopped before carrying out any work.

Slacken the cap to the first notch to release the pressure to prevent any risk of scalding.

When the pressure has dropped, remove the cap and top up the level.

Note: the coolant does not need to be changed.

Used oil

Do not dispose of used oil, brake fluid or coolant into drains or into the ground.

Power steering reservoir

☞ Open the reservoir, with the engine at ambient temperature. The level should always be above the MIN. mark and close to the MAX. mark.

Windscreen and headlamp* wash level

For best quality cleaning and for your safety, we would advise that you use products recommended by PEUGEOT.

* According to destination.

PRACTICAL INFORMATION

CHECKS

Battery

At the start of winter, have your battery checked by a PEUGEOT dealer.

Air filter and passenger compartment filter

Have the filter elements replaced regularly. **If you drive in dusty conditions, change them twice as often.**

Brake pads

Brake pad wear depends on the style of driving, in particular for vehicles which are used in town, over short distances.

It may be necessary to check the thickness of the pads, even between services.

Handbrake

Where the handbrake travel is too great or there is a reduction in the performance of the system, the handbrake should be adjusted, even between services.

Have the system checked by a PEUGEOT dealer.

Manual gearbox

This does not need an oil change. Check the level, according to the manufacturer's servicing schedule.

Automatic gearbox

This does not need an oil change. Have the level checked by a PEUGEOT dealer, according to the manufacturer's servicing schedule.

Oil filter

Change the filter regularly, in accordance with the servicing schedule.

RUNNING OUT OF FUEL (DIESEL)

If you should run out of fuel, it is necessary to re-prime the circuit:

- fill the fuel tank with at least five litres of diesel,
- operate the manual re-priming pump, until you feel resistance during the manoeuvre,
- operate the starter until the engine starts.



Only use products recommended by PEUGEOT.

To ensure best performance from components as important as the power steering and the braking system, PEUGEOT selects and offers quite specific products.

PRACTICAL INFORMATION

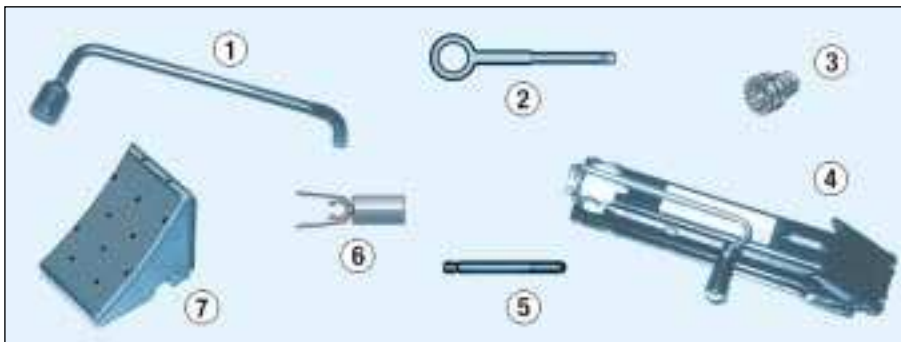

CHANGING A WHEEL

Tools

The following tools are located:

- in the right-hand trim of the boot,
 - 1 - Wheelbrace.
 - 2 - Removable towing eye.
 - 3 - Socket for anti-theft bolts.
- in the holder in the centre of the spare wheel,
 - 4 - Jack with handle.
 - 5 - Bolt cover tools.
 - 6 - Centralising tool.
 - 7 - Removable chock.

Parking the vehicle

- ☞ As far as possible, park the vehicle on level, stable and non-slippery ground.
- ☞ Apply the handbrake, switch off the ignition and engage first or reverse gear (position **P** for the automatic gearbox).

Access to the spare wheel

- ☞ Open the boot.
- ☞ Open the flap using the lug to release the winch and gain access to its control nut.
- ☞ Unscrew the nut fully, using the wheelbrace 1, to unroll the winch cable.

PRACTICAL INFORMATION



- ☞ Detach the wheel/holder assembly from the rear of the vehicle.
- ☞ Take out the notched hook to release the wheel, as shown in the illustration.



Removing the wheel

- ☞ Slide the holder cover to gain access to the tools.
 - ☞ Place the chock 7 under the wheel diagonally opposite to the one to be changed.
 - ☞ Remove the trim, using the wheelbrace 1, pulling at the valve passage hole (for vehicles fitted with steel wheels).
 - ☞ Loosen the wheel bolts (see § "Special features of alloy wheels" for vehicles fitted with alloy wheels).
- Note:** you can use the other end of the tool 6 to unscrew the wheel bolts.

- ☞ Place the jack 4 in contact with one of the four locating points A on the sub-frame, the one which is closest to the wheel to be changed.
- ☞ Extend the jack 4 until its base is in contact with the ground. Ensure that the centre line of the base of the jack is straight above the locating point A.
- ☞ Raise the vehicle
- ☞ Remove one bolt and install the centralising tool 5 in its place.
- ☞ Unscrew the other bolts and remove the wheel.

PRACTICAL INFORMATION

Fitting a wheel

- ☞ Position the wheel using the centralising tool **5** to assist you.
- ☞ Tighten the bolts by hand and remove the centralising tool **5**.
- ☞ Partly tighten the bolts using the wheelbrace **1**.
- ☞ Fold the jack **4** and remove it.
- ☞ Fully tighten the bolts using the wheelbrace **1**.
- ☞ Replace the wheel trim, starting by placing the wheel trim notch opposite the valve, and press it on using the palm of the hand.
- ☞ Put the corresponding tools in the holder and secure its cover.
- ☞ Place the holder on the ground and align the spare wheel on it.
- ☞ Pass the notched hook into the holder cover.
- ☞ Refit the wheel under the vehicle tightening the winch control nut using the wheelbrace **1**.
- ☞ Fully tighten and **check that the wheel is horizontally flush against the rear floor.**

- ☞ Close the flap using the lug to lock the winch.
- ☞ Store the rest of the tools in the right-hand trim of the boot.



For your safety, always change the wheel:

- on level, stable, non-slippery ground,
- with the handbrake on and the ignition switched off,
- with first or reverse gear engaged (position **P** for the automatic gearbox),
- with the vehicle chocked.

Never go underneath a vehicle that is supported only by a jack (use a ramp)

Never refit the holder under the vehicle without the spare wheel.

After changing the wheel:

- have the correct positioning of the punctured wheel, the tightening of the bolts and the tyre pressure checked by a PEUGEOT dealer as soon as possible.
- have the punctured tyre repaired and refit it to the vehicle as soon as possible.
- have the correct positioning of the spare wheel checked by a PEUGEOT dealer.

PRACTICAL INFORMATION

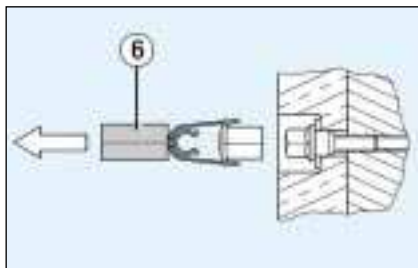

Special features of alloy wheels

Bolt covers

Alloy wheel bolts are covered by chrome trims.

Use tool **6** to remove the trims before slackening the bolts.

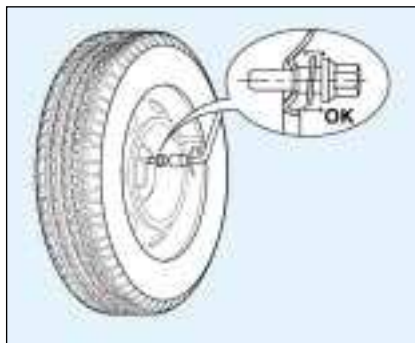

Fitting the spare wheel

If your vehicle is fitted with a steel spare wheel, when fitting it, it is **normal** when tightening the bolts, to notice that the washers do not come into contact with the rim. The spare wheel is secured by the cone shape of each bolt.

Fitting snow tyres

If you fit snow tyres mounted on steel wheels onto your vehicle, it is **essential** to use special bolts available from your PEUGEOT dealer.

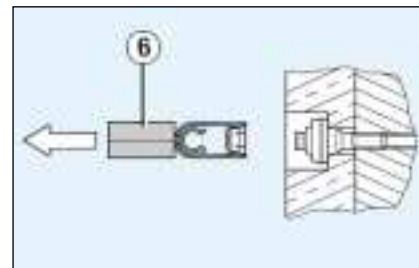

Anti-theft bolts*

If your wheels are fitted with an anti-theft bolt (one per wheel), the chrome trim and then the plastic cover must be removed using tool **6**, before unscrewing the bolt using one of the two anti-theft sockets (which were given to you on delivery of your vehicle along with the duplicate keys and the confidential card) and the wheel brace **1**.

Note : make a careful note of the code number engraved on the head of the anti-theft socket. This will enable you to obtain duplicate anti-theft sockets from a PEUGEOT dealer.

* According to model and country

PRACTICAL INFORMATION

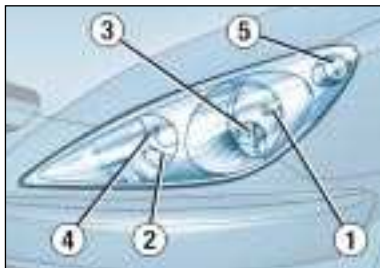

CHANGING A BULB

Front lights

Note: on the right-hand side, remove the style cover, fixed with two plastic screws, to access the bulbs. Handle the bulbs with a dry cloth.

1 - Dipped beam headlamps (H7-55W).

2 - Main beam headlamps (H1-55W).

3 - Front fog lamps (H1-55 W).

- ☞ Turn the protective cover corresponding to the faulty bulb a quarter of a turn and remove it.
- ☞ Disconnect the connector.
- ☞ Press the end of the securing clip to free it. Change the bulb.

When fitting the new bulb, ensure that the direction notches are positioned correctly and the securing clip is fixed properly.

- ☞ Reconnect the connector.
- ☞ Refit the protective cover, positioning it with the arrow upwards, then turn it a quarter of a turn to the right.



The headlamps are fitted with polycarbonate glass with a protective coating. **Do not clean them with a dry or abrasive cloth, nor with a detergent or solvent product.** Use a sponge and soapy water.

4 - Side lights W 5 W.

- ☞ Pull the socket rearwards, remove the bulb and change it.

5 - Direction indicators (PY 21 W amber).

- ☞ Turn the bulb holder a quarter of a turn and remove it.
- ☞ Change the bulb.

Note: In certain climatic conditions (low temperature, humidity), **condensation inside the headlamp glass is normal**; it disappears a few minutes after the lights are switched on.

PRACTICAL INFORMATION

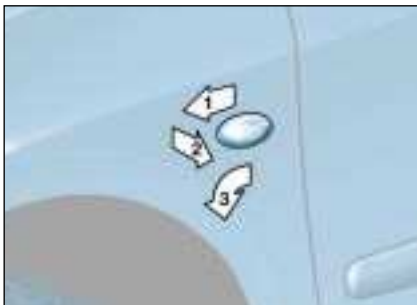

Direction indicator side repeaters (WY 5W amber).

- ☞ Push the repeater forwards and release the assembly.
- ☞ Hold the connector and turn the lens a quarter turn.
- ☞ Change the bulb.



Amber coloured bulbs (direction indicators and side repeaters), must be replaced with bulbs of identical specification and colour.

PRACTICAL INFORMATION

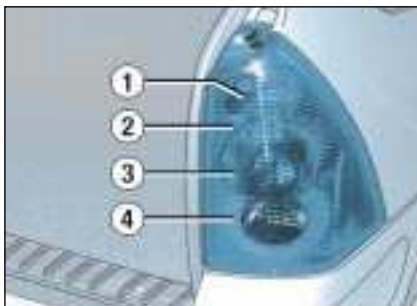

Rear lights

- 1 - Brake lights (P 21 W).
- 2 - Side lights (R 5 W).
- 3 - Direction indicators (P 21 W).
- 4 - Reversing light (P 21 W), right side.
- Fog lamp (P 21 W), left side.

These 5 bulbs are changed by removing the light:

- ☞ Remove the corresponding boot side trim to access the light,
- ☞ Remove the light fixing nut inside the boot,
- ☞ Remove the light fixing nut outside the boot,
- ☞ Remove the light,
- ☞ Unclip the harness,

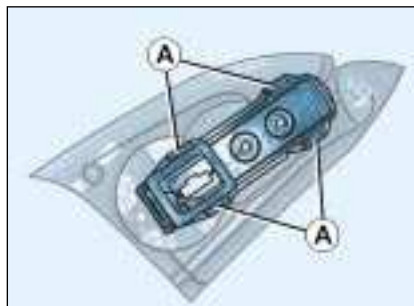

- ☞ Remove the bulb holder pressing on the tabs **A**,
- ☞ Change the faulty bulb.

Note: if necessary, use the wheel-brace to remove the nuts.

When refitting, take care to position the bulb holder and the light correctly.

Number plate lights (W 5 W)

- ☞ Insert a thin screwdriver into one of the external holes of the lens.
- ☞ Push it outwards to unclip it.
- ☞ Remove the lens.
- ☞ Change the faulty bulb.

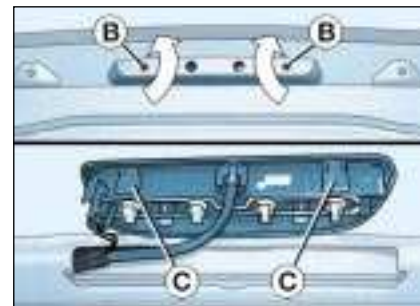

Third brake light: 4 W 5 W bulbs.

- ☞ Remove the tailgate upper trim carefully by unclipping it on either side, perpendicular to its direction of engagement.
- ☞ Insert a screwdriver into the two outer holes **B** to press on the two tabs **C**.
- ☞ Push the light unit outwards while maintaining the pressure on the tabs.
- ☞ Pull the light unit outwards while tilting it.
- ☞ Change the faulty bulb.
- ☞ When refitting, ensure that the light unit tabs are engaged correctly and that the tailgate upper trim has been put back in place correctly.

PRACTICAL INFORMATION

CHANGING A FUSE

The fuse boxes are located under the fascia (driver's side) and in the engine compartment.

The spare fuses and special pliers **A** are fixed to the inside of the lid of the fascia fuse box.

Removing and changing a fuse

Before changing a fuse you must establish the cause of the fault and have it corrected. The fuse numbers are indicated on the fuse box.

☞ Use the special pliers **A**.

Always change a faulty fuse for one of the same rating.



Correct



Incorrect



Pliers **A**



Fascia fuses

☞ Unscrew the bolt a quarter of a turn with a coin, then pull the handle to open the cover and access the fuses.

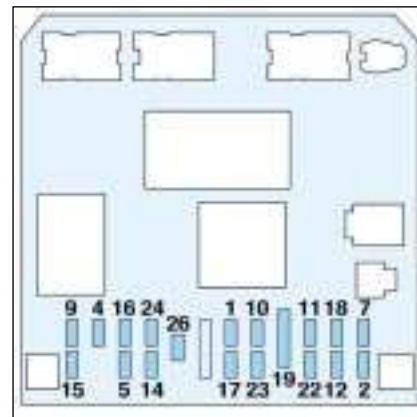

Fuse no.	Rating	Functions
1	10 A	Rear fog lamp.
2	15 A	Rear screen wiper.
4	15 A	Front electric windows.
5	15 A	Left brake light including trailer.
7	30 A	Rear courtesy light, front courtesy light, map readers - 12 V front socket - Glove box lighting - Concealing flap control.

PRACTICAL INFORMATION

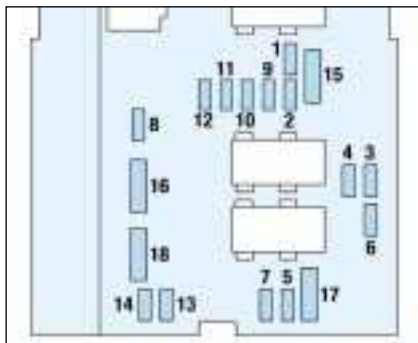

Engine compartment fuses

Fuse box

To access the fuse box in the engine compartment (next to the battery):

☞ unclip the cover.

Carefully close the cover and refit the style cover when you have finished.

Fuse no.	Rating	Functions
1*	50 A	Fan unit.
2*	30 A	ESP/ABS pump motor.
3*	30 A	ESP/ABS solenoid valves.
4*	70 A	Built-in Systems Interface supply.
5*	70 A	Built-in Systems Interface supply.
6*	20 A	Heated seats.
7*	30 A	Ignition switch, power.
8*	70 A	Power steering electro-pump unit.



The electrical system of your vehicle is designed to operate with standard or optional equipment.

Before installing other electrical equipment or accessories on your vehicle, contact a PEUGEOT dealer.

PEUGEOT will not accept responsibility for the cost incurred in repairing your vehicle or for rectifying the malfunctions resulting from the installation of accessories not supplied and not recommended by PEUGEOT and not installed in accordance with its instructions, in particular where the equipment in question consumes more than 10 milliamperes.

** The maxi-fuses provide additional protection for the electrical systems. All work must be carried out by a PEUGEOT dealer.*

PRACTICAL INFORMATION

Fuse N°	Rating	Functions
1	10 A	Automatic gearbox reversing lights switch - Automatic gearbox starting inhibitor relay control - Manual gearbox reversing lights switch - Vehicle speed sensor - Water in diesel sensor.
2	15 A	Canister solenoid valve - Fuel pump.
3	10 A	Power steering control unit - ABS or ESP control unit.
4	10 A	Injection control unit - Fan unit relay control - Additional heating relay control - Automatic gearbox control unit - Automatic gearbox sequential control - Automatic gearbox shiftlock relay.
5	15 A	Particulate emission filter control unit.
6	15 A	Front fog lamps.
7	20 A	Headlamp wash pump.
8	20 A	Fan unit relay control - Engine control unit supply - Injection pump (Diesel).
9	15 A	Left dipped beam.
10	15 A	Right dipped beam.
11	10 A	Right main beam.
12	10 A	Left main beam.
13	15 A	Horn.
14	10 A	Front and rear wash-wipe pumps.
15	30A	Oxygen sensors - Exhaust gas recirculation solenoid valve - Ignition coil - Diesel high pressure regulator - Injectors supply (petrol) - Pre-heating control unit - Air flow sensor (Diesel) - Engine control unit (Diesel) - Injection pump (Diesel) - Diesel heater.
16	30A	Petrol engine air pump with automatic gearbox.
17	30A	Low/high speed front wiper.
18	40A	Air conditioning blower.

PRACTICAL INFORMATION

CHANGING A FUSE

The fuse boxes are located under the fascia (driver's side) and in the engine compartment.

The spare fuses and special pliers **A** are fixed to the inside of the lid of the fascia fuse box.

Removing and changing a fuse

Before changing a fuse you must establish the cause of the fault and have it corrected. The fuse numbers are indicated on the fuse box.

☞ Use the special pliers **A**.

Always change a faulty fuse for one of the same rating.



Correct



Incorrect



Pliers **A**



Fascia fuses

☞ Unscrew the bolt a quarter of a turn with a coin, then pull the handle to open the cover and access the fuses.

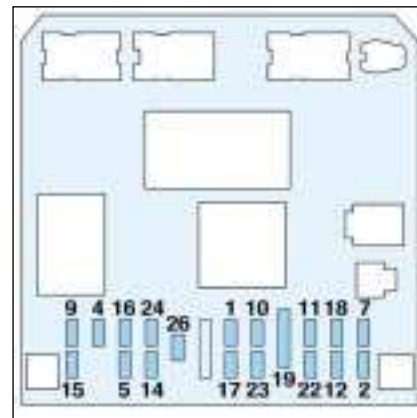

Fuse no.	Rating	Functions
1	10 A	Rear fog lamp.
2	15 A	Rear screen wiper.
4	15 A	Front electric windows.
5	15 A	Left brake light including trailer.
7	30 A	Rear courtesy light, front courtesy light, map readers - 12 V front socket - Glove box lighting - Concealing flap control.

PRACTICAL INFORMATION

Fuse no.	Rating	Functions
9	30 A	Front electric windows - Front press operation windows (incompatible with non-press operation windows) - Panoramic roof concealing flap.
10	15A	Diagnostic socket - 12 V rear socket - Trailer.
11	20A	Audio equipment - Multi-function display - Steering wheel controls - Automatic gearbox.
12	10A	Front right and rear right side lights - Number plate and trailer lighting - Central locking switches/ alarm/hazard warning lights lighting- Air conditioning/ashtray light - Heated seats switches/automatic gearbox lighting- Lighter.
14	30 A	Door opening/closing controls - Deadlocking controls.
15	30A	Press-operation electric rear windows.
16	10A	Engine fuse box - Alarm - Particulate emission filter - Steering wheel controls - Air bags.
17	10A	Rear right brake light, 3rd brake light.
18	10 A	Diagnostic socket - Steering wheel controls - Electrochromatic mirror - Brake pedal (stop) and clutch switches - Coolant level switch - Second brake switch.
19	30 A	PARC shunt.
22	10 A	Front left and rear left side lights - Number plate and trailer lighting.
23	15 A	Alarm siren - Interior alarm control unit.
24	15 A	Instrument panel - Audio equipment - Multi-function displays - Air conditioning - Rear parking aid.
26	30 A	Heated rear screen.

PRACTICAL INFORMATION

CHANGING A WINDSCREEN WIPER BLADE

Placing the wiper blades in the maintenance position

- ☞ Within one minute of switching off the ignition, operate the wipers stalk to position the wiper blades in the centre of the windscreen (maintenance position).

Changing a wiper blade

- ☞ Lift the wiper arm, then unclip the blade and remove it.
- ☞ Fit the new blade and push back the arm.

Note : the shortest blade is fitted on the vehicle's right-hand windscreen wiper arm.

To return the windscreen wipers to their normal position, switch on the ignition and operate the wiper stalk.

ECONOMY MODE FUNCTION

After the engine has stopped, certain functions (windscreen wipers, electric windows, panoramic roof concealing flap, courtesy lights, audio equipment etc.) can only be used for thirty minutes, to prevent discharging the battery.

Once the thirty minutes are over, the message "**Economy mode active**" appears on the multi-function display and the active functions are put on standby.

To resume use of these functions, start the engine and let it run for a few seconds.



A flat battery will prevent the engine from starting.

LOAD REDUCTION FUNCTION

When driving, certain functions (air conditioning, heated rear screen, heating system for passenger compartment of diesel vehicles, etc.) may be switched off temporarily, depending on the level of battery charge.

Reactivation of these functions is automatic, once the battery charge is sufficient.

Note: at the risk of discharging the battery, the functions that have been switched off may be reactivated manually.

PRACTICAL INFORMATION

BATTERY

To charge the battery using a battery charger:

- Disconnect the battery,
- Follow the instructions for use given by the battery charger manufacturer,
- Reconnect starting with the negative (-) terminal,
- Check that the terminals and connectors are clean. If they are covered with sulphate (white or greenish deposit), disconnect them and clean them.

To start the vehicle from another battery:

- Connect the red cable to the positive (+) terminals of the two batteries,
- Connect one end of the green or black cable to the negative (-) terminal of the slave battery,
- Connect the other end of the green or black cable to an earth point on the broken down vehicle as far as possible from the battery,

Operate the starter, let the engine run.

Wait for the engine to return to idle, then disconnect the cables.

It is advisable to disconnect the battery if the vehicle is not to be used for a period of more than one month.



- *Never disconnect a terminal when the engine is running.*
- *Never charge a battery without first disconnecting the terminals.*
- *After every reconnection of the battery, switch on the ignition and wait 1 minute before starting to allow the electronic systems to be initialised. If slight difficulties are experienced after this, please contact a PEUGEOT dealer.*

PRACTICAL INFORMATION

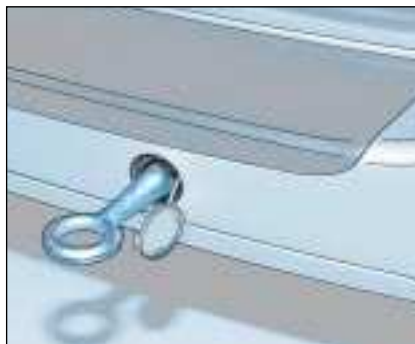

TOWING YOUR VEHICLE

Without lifting (4 wheels on the road)

You should always use a tow bar.

The removable towing eye is inside the boot right-hand trim.

From the front:

- ☞ Unclip the cover, by pressing the bottom part,
- ☞ Screw in the removable towing eye as far as it will go.

From the rear:

- ☞ Unclip the top of the cover using a coin,
- ☞ Screw in the removable towing eye as far as it will go.

Lifting (2 wheels only on the road)

It is preferable to raise the vehicle with a professional lifting device.

Special features of the automatic gearbox

When towing with four wheels on the ground, the following rules must be obeyed:

- lever in position **N**,
- tow the vehicle at less than 50 km/h over a maximum distance of 50 km,
- do not add oil to the gearbox.



When towing with the engine switched off, there is no braking or steering assistance.

PRACTICAL INFORMATION

TOWING A TRAILER, CARAVAN, BOAT ETC.

Only use original PEUGEOT tow bars that have been tested and approved from the design stage of your vehicle. The tow bar must be fitted by a PEUGEOT dealer.

Your vehicle is basically designed for transporting people and luggage but it may also be used for towing a trailer.

Driving with a trailer subjects the towing vehicle to more significant stress and its driver must be particularly careful.

Air density decreases with altitude, thus reducing engine performance. Above 1000 metres, the maximum towing load must be reduced by 10% and so on for every 1000 metres of altitude.

Driving advice

Distribution of loads

Distribute the load in the trailer so that the heaviest items are as close as possible to the axle and the nose weight approaches the maximum permitted without exceeding it.

Cooling

Towing a trailer on a slope increases the temperature of the coolant.

As the fan is electrically controlled, its cooling capacity is not dependent on the engine speed.

On the contrary, use a high gear to lower the engine speed, and reduce your speed.

The maximum towing load on a long slope depends on the gradient and the outside temperature.

In all cases, pay attention to the coolant temperature.

If the warning light comes on, stop the vehicle and switch off the engine as soon as possible.

Tyres

Check the tyre pressures of the towing vehicle and of the trailer, observing the recommended pressures.

Braking

Towing increases the braking distance.

Lights

Check the electrical signalling on the trailer.

Side wind

Take into account the increased sensitivity to side wind.

PRACTICAL INFORMATION

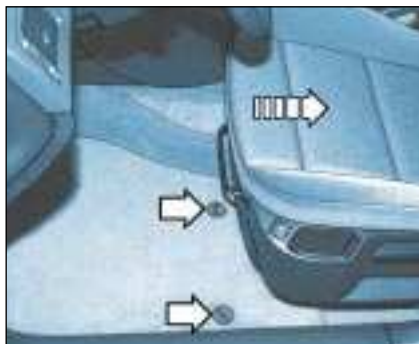

REMOVING THE MAT

When removing the mat on the driver's side, push the seat as far back as possible and unscrew the fixings. When refitting, position the mat and replace the fixings by pressing them in.

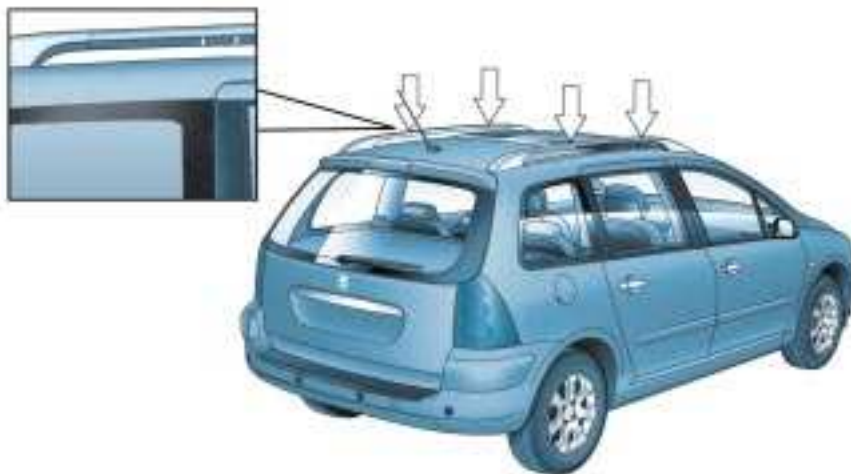

FITTING ROOF BARS

When fitting transverse roof bars, ensure that they are positioned correctly.

The correct positions are shown by marks on each of the longitudinal bars.

Use accessories approved by PEUGEOT and follow the manufacturer's fitting instructions.

**Maximum authorised
weight on the roof rack
100 kg**

PRACTICAL INFORMATION



ENTERTAINMENT SCREEN KIT

This video assembly will enable the rear passengers to pass the time pleasantly while watching their favourite film or playing their favourite game, by means, in particular, of the connection of a DVD player or games console to the central support, fitted between the front seats.

The entertainment screen kit consists of:

- a 16/9ths, 7 inch, LCD colour monitor with direction adjustment in the three axes,
- two high frequency, wireless, stereo headphones,
- a removable support,
- three audio/video sockets on the fixed base and in the glove compartment.

The monitor and the support can be removed and stored, each in their own protective cover.

The entertainment screen kit accepts all types of audio/video source, PAL/NTSC compatible, such as: DVD player, camcorder, games console, ...

These sources are connected to the three audio/video sockets, **AV1** in the glove compartment or **AV2** on the fixed base.

PRACTICAL INFORMATION

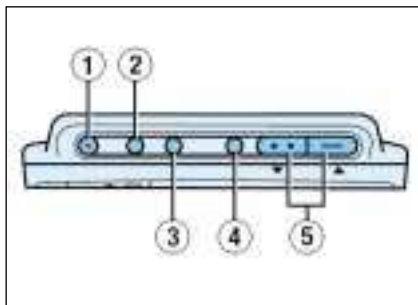

The upper face of the monitor incorporates the following controls:

- 1 - "POWER" button to switch the monitor on/off.
- 2 - "FUNC" button for selection of the input source, AV1 or AV2.
- 3 - "WIDE" button to change the display format (normal, full screen, wide, cinema).
- 4 - "MENU" button for selection of the menus and settings.
- 5 - "▲" and "▼" buttons to change the settings.

By pressing buttons **4** and **5**, you can adjust the brightness, the contrast, the colours, ...

For further details, refer to the operating manuals "Video kit operation" and "VMA8582 7 inch LCD colour monitor".

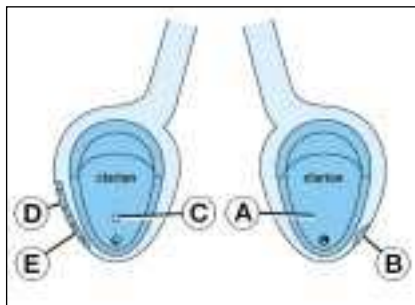

Various controls are incorporated in the headphones:

- A** - Housing for the two LR03 batteries.
- B** - Headphones on/off button.
- C** - On/off indicator light.
- D** - Tuning frequency adjustment control.
- E** - Headphones volume adjustment control.

To get the best out of the headphones, you must adjust their size to suit you, find their tuning frequency by rotating control **D**, then adjust the volume by rotating control **E**.

PRACTICAL INFORMATION

ACCESSORIES FOR YOUR 307 SW

For your PEUGEOT only use accessories and original parts approved by the manufacturer.

These accessories and parts are all adapted to your PEUGEOT, after being tested and approved for reliability and safety, which PEUGEOT cannot guarantee for other products.

A wide choice of original accessories, approved by PEUGEOT, is available through the dealer network. They all carry the PEUGEOT guarantee.

- **Safety** : Anti-theft alarm, window engraving, wheel locks, first aid kit, warning triangle, rear parking assistance.
- **Comfort** : Telephone console, front centre arm rest, covers compatible with side air bags, mats, boot tray, cool box, door deflectors, CD storage, side sun blinds and rear blind, additional seats...
- **Communication** : Audio system, telephone, hands-free kit, speakers, amplifiers, CD changer, navigation systems, entertainment screen kit, DVD player...
- **Customising** : Alloy wheels, trims, sport exhaust, aluminium or PVC door sills, mud flaps...
- **Leisure** : Tow bar, transverse roof bars, roof box, snow chains, ski carrier, roof bars bicycle carrier, tailgate bicycle carrier*...
- **Children** : Booster seats and child seats...
- **Maintenance products** : Screenwash, interior and exterior cleaning and maintenance products...
- **Commercial use** : Kit for transformation into a van...

* During the year.



Before installing any electrical accessory on your vehicle, contact a PEUGEOT dealer.

TECHNICAL DATA

MODELS: Model codes	PETROL ENGINES			
	3HNFUB 3HNFUC/IF	3HNFUE 3HNFUF/IF	3HRFNC/IF	3HRFNE
ENGINES	1.6 litre 16V		2 litre 16V	
Cubic capacity (cm ³)	1 587		1 997	
Bore x stroke (mm)	78,5 x 82		85 x 88	
EU standard maximum power (kW)	80		100	
Maximum power at engine speed (rpm)	5 800		6 000	
EU standard maximum torque (Nm)	147		190	
Maximum torque at engine speed (rpm)	4 000		4 100	
Fuel	Unleaded		Unleaded	
Catalytic converter	Yes		Yes	
GEARBOX	Manual (5 speed)	Automatic (4 speed)	Manual (5 speed)	Automatic (4 speed)
OIL CAPACITIES (litres)				
Engine (with cartridge replacement)	3	3	4,25	4,25
Gearbox-Final drive	2	-	1,9	-

TECHNICAL DATA

MODELS: Model codes	DIESEL ENGINES	
	3HRHYB	3HRHSB
ENGINES	2 litre Turbo HDI 90 bhp	2 litre Turbo HDI 110 bhp
Cubic capacity (cm ³)	1 998	1 997
Bore x stroke (mm)	85 x 88	85 x 88
EU standard maximum power (kW)	66	79
Maximum power at engine speed (rpm)	4 000	4 000
EU standard maximum torque (Nm)	205	250
Maximum torque at engine speed (rpm)	1 900	1 750
Fuel	Diesel	Diesel
Catalytic converter	Yes	Yes
Particulate emission filter	Non	Yes
GEARBOX	Manual (5 speed)	Manual (5 speed)
OIL CAPACITIES (litres)		
Engine (with cartridge replacement)	4,5	4,5
Gearbox-Final drive	1,9	1,85

TECHNICAL DATA

.....

Consumption			In accordance with directive 99/100 [In MPG (litres/100km)]			
Engine	Gearbox	Model codes	Circuit Urban	Circuit Inter-urban	Circuit Mixed	Emission of CO ₂ by weight (g/km)
1,6 litre 16V	Manual	3HNFUB 3HNFUC/IF	9,9	6,3	7,7	178
1,6 litre 16V	Automatic	3HNFUE 3HNFUF/IF	11,2	6,4	8,3	194
2 litre 16V	Manual	3HRFNC/IF	11,5	6,3	8,3	194
2 litre 16V	Automatic	3HRFNE	13,1	6,5	8,8	206
2 litre Turbo HDI 90 hp	Manual	3HRHYB	7,1	4,5	5,4	143
2 litre Turbo HDI 110 hp	Manual	3HRHSB	7,2	4,4	5,4	143

Fuel consumption values correct at time of printing.

TECHNICAL DATA

Weights and Towing loads (in kg)

PETROL				
Engine	1,6 litre 16V		2 litre 16V	
Gearbox	Manual	Automatic	Manual	Automatic
Model codes :	3HNFUB 3HNFUC/IF	3HNFUE 3HNFUF/IF	3HRFNC/IF	3HRFNE
• Kerb weight	1399	1435	1430	1466
• Gross vehicle weight (GVW)	1923	1959	1941	1977
• Gross train weight (GTW*)	3023	3059	3441	3477
• Unbraked trailer	695	715	715	730
• Braked trailer (within GTW)	1100	1100	1500	1500

DIESEL		
Engine	2 litre Turbo HDI 90 hp	2 litre Turbo HDI 110 hp
Gearbox	Manual	Manual
Model codes :	3HRHYB	3HRHSB
• Kerb weight	1465	1496
• Gross vehicle weight (GVW)	1984	2016
• Gross train weight(GTW*)	3484	3516
• Unbraked trailer	730	745
• Braked trailer (within GTW)	1500	1500

* The speed of a towing vehicle is limited to 60 mph (100 km/h).

TECHNICAL DATA

DIMENSIONS (in mm)

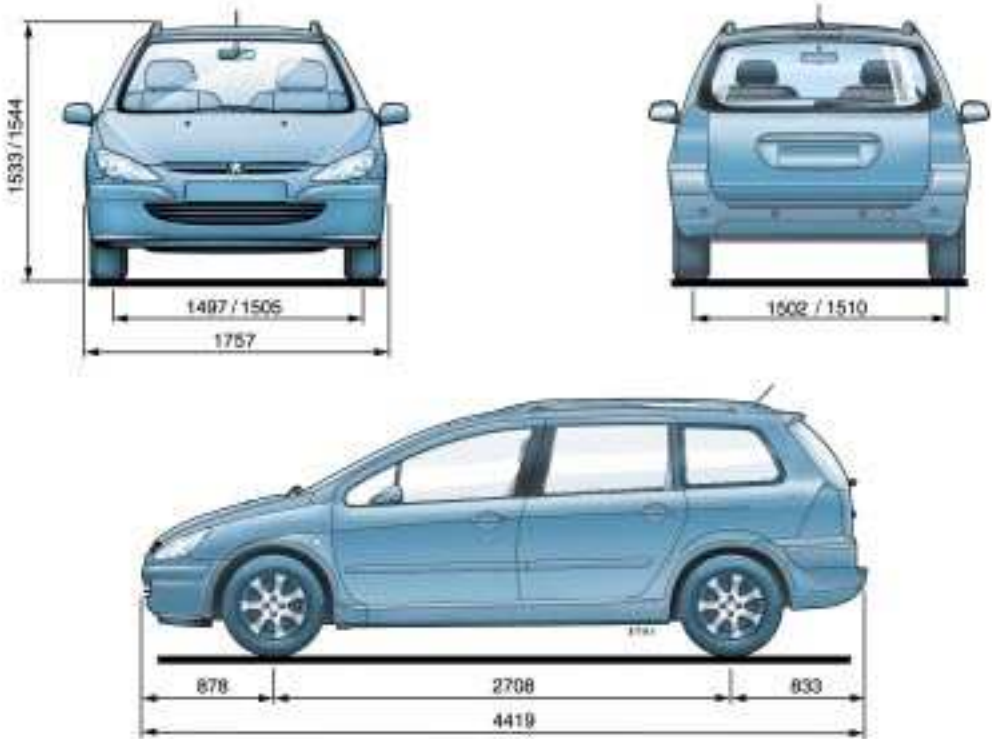

TECHNICAL DATA

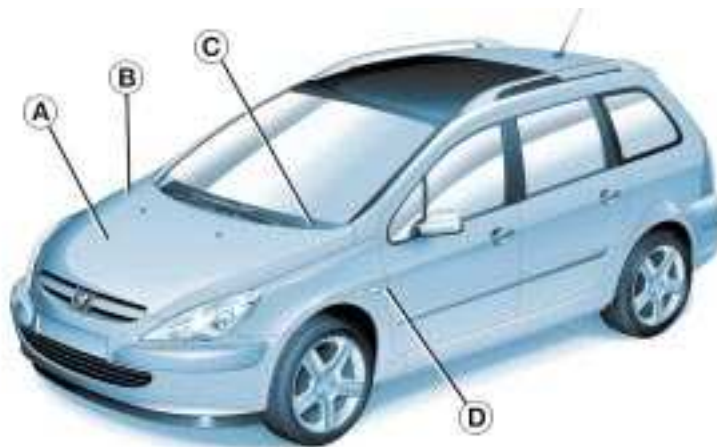

THE IDENTIFICATION FEATURES OF YOUR 307 SW

- A. **Manufacturer's plate.**
- B. **Serial number on the bodywork.**
- C. **Serial number on the fascia.**
- D. **Tyres and paint colour reference.**

The label **D** on the driver's door pillar, near the hinges, indicates:

- the wheel and tyre sizes,
- the brands of tyres approved by the manufacturer,
- the tyre pressures (**the tyre pressure must be checked when the tyre is cold, at least once a month**),
- the paint colour reference.