

YOUR 106 AT A GLANCE

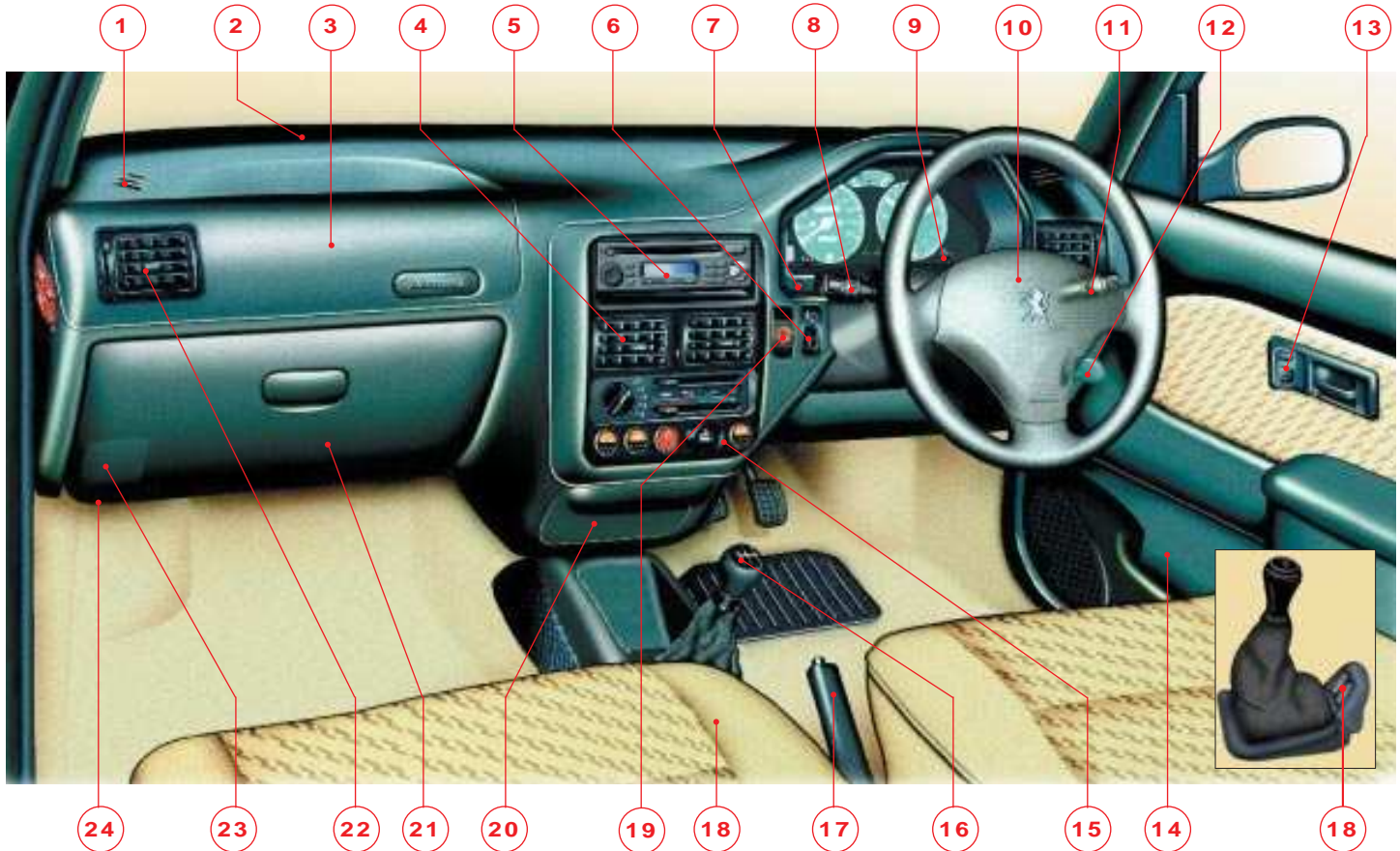

- 1 - Side windows demisting vents
- 2 - Windscreen demisting vents
- 3 - Passenger airbag
- 4 - Adjustable centre vents
- 5 - Radio cassette player or spare
- 6 - Headlamp height adjustment
- 7 - Interior alarm protection disarm button
- 8 - Lights, fog lamps and horn stalk
- 9 - Instrument panel lighting rheostat
- 10- Steering wheel with AIR BAG
- 11- Windscreen wash/wipe stalk
- 12- Ignition, ignition lock and engine immobiliser
- 13- Electric mirrors switch
- 14- Storage compartment
- 15- Controls for:
 - Air conditioning or left-hand heated seat
 - Lighter
 - Hazard warning lights
 - Rear screen and mirrors demisting
 - Air recirculation or right-hand heated seat
- 16- Gear lever
- 17- Handbrake
- 18- Electric window switches
- 19- Passenger airbag disarming switch
- 20- Ashtray
- 21- Glove box
- 22- Adjustable side vent
- 23- Fuse box
- 24- Bonnet opening control



LOCKING AND UNLOCKING

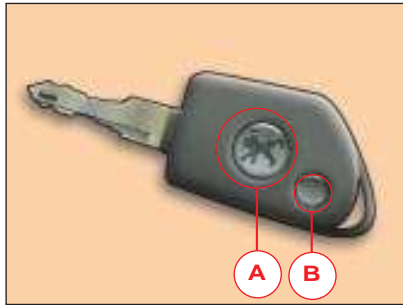

The remote control

A single press on button **A** locks the doors and boot or tailgate.

A single press on button **B** unlocks the vehicle.



Key

The key switches on the ignition, locks and unlocks the doors, tailgate, fuel filler flap and disarms the passenger airbag.



Keep your key number in a safe place.

This will enable you to obtain a new key if it is lost or stolen.

**ENGINE
IMMOBILISER**

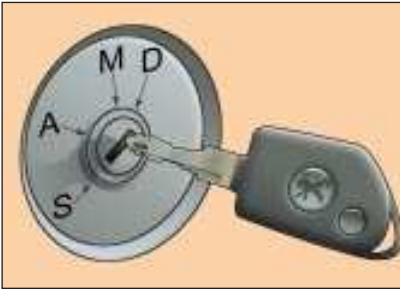

This locks the engine control system and therefore prevents starting of the vehicle by anyone who does not have the key.

Operation

Each key has a special code.

When the ignition is switched on the key code is recognised by the engine immobiliser system and starting is possible.

The engine immobiliser automatically locks the engine control system a few moments after the ignition has been switched off.



Confidential card

This shows the identification code which is required if any work is carried out on the system by your PEUGEOT dealer. This code is hidden by a film which must not be removed unless required.

Keep your card in a safe place, never in your vehicle.



When buying a second-hand car:

- *Make sure that you are given the confidential card.*
- *It is advisable to have the key codes memorised by your PEUGEOT dealer in order to ensure that the keys in your possession are the only ones which can start the vehicle.*

50 SEATS WITH MANUAL CONTROLS



1. Forwards-backwards adjustment.
2. Seat back angle adjustment.
3. Access to rear seats (3 door).

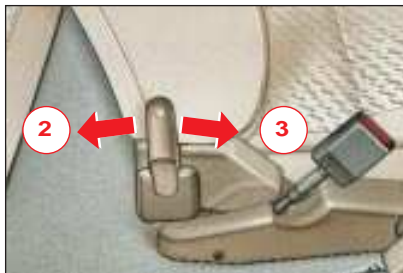

For models fitted with air conditioning, the storage compartment for the handbook and maintenance guide is under the passenger seat.

71 FRONT AND SIDE AIRBAGS



Disarming the passenger airbag. Insert the ignition key in switch 1 and turn it:

- to the «ON» position, the passenger airbag is armed,
- to the «OFF» position, the passenger airbag is not armed.



Operational Check

This is by means of the warning light on the instrument panel.

If the passenger airbag is armed or if your vehicle is not fitted with a passenger airbag, the warning light comes on for 6 seconds when the ignition is switched on.

If the passenger airbag is not armed, the warning light remains on.

Always contact your PEUGEOT dealer if the warning light flashes.

Passenger airbag precautions

For a vehicle fitted with a disarming switch:

- disarm the airbag if you install a rear-wards-facing child seat,
- arm the airbag when an adult is in the seat.



For a vehicle not fitted with a disarming switch:

- do not install rear-wards-facing child seats on the front passenger seat.





Never place your feet or any object on the fascia.

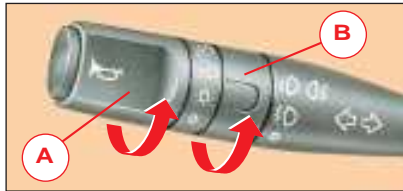

62 LIGHTING - HORN





Ring A Lighting controls

-  Lights off
-  Side lights
-  Dipped/
main beam lights

Ring B Rear fog lamp control

-  Rear fog lamp off
-  Rear fog lamp on

Front/rear fog lamps control

-  Fog lamps off
-  Front fog lamps on
-  Front/rear fog lamps on

63 FRONT AND REAR WINDSCREEN WIPER

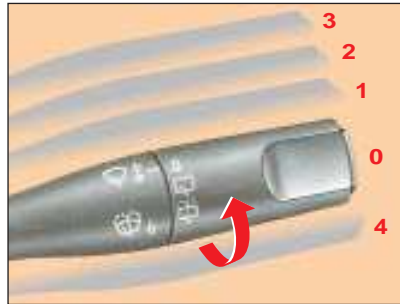



Front

- 3 - High speed wipe
- 2 - Normal speed wipe
- 1 - Intermittent wipe
- 0 - Stop
- 4 - Single wipe

Pulling the stalk towards you washes the windscreen with timed sweep, and headlamp wash if headlamps are on.

Rear

-  Off
-  Intermittent or continuous wipe
-  Windscreen wash

65 EXTERIOR MIRRORS

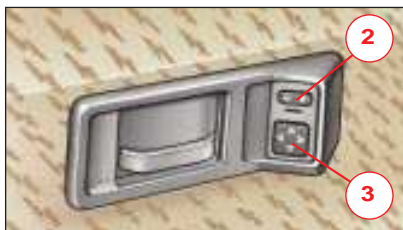

Manual adjustment

- Adjust the position using the lever 1.

Electric adjustment:

- Using the two-way switch 2, select the left-hand or right-hand mirror, then adjust its position using button 3.
- Return the two-way switch 2 to the central position.

 Demisting of the mirrors is linked to the rear screen demisting control.

47 HEATING/AIR CONDITIONING



1 - Air flow adjustment

2 - Air distribution



To the central and side vents



Footwells



Windscreens, side screens and footwells



Windscreen and side windows



3 - Temperature control



4 - Air conditioning on/off



5 - Interior air recirculation

PEUGEOT SERVICING

Your vehicle benefits from extended service intervals:

- Every 20 000 miles (30 000km) or every 2 years for petrol engines.
- Every 10 000 miles (15 000km) or every 2 years for indirect injection diesel engines.

The extension of the service intervals means that the engine oil level must be checked regularly; topping up of the oil between oil changes is normal.

It is for this reason, and for your complete peace of mind, that your Peugeot dealer will carry out a levels check and top-up midway between each routine service, at the time or distance intervals specified. This will be undertaken free of charge, provided that the maintenance of your vehicle has been carried out within the Peugeot network. At the same time, your Peugeot dealer will offer you a Peugeot Safety Check, for a nominal fee. A Peugeot professional will carry out a quick check and will top up the levels if necessary (oil up to 1 litre, coolant and screen wash).

If the oil level is too low, there is a risk of serious damage to the engine: check the engine oil level at least every 1,500 miles (2,500km), depending on the conditions of use.

The date of the intermediate visit is not shown by the service indicator. It is to be carried out at least every 10 000 miles (15 000km) for petrol engines and every 5 000 miles (7 500km) for indirect injection diesel engines.

The extended service intervals have been made possible by technical modifications to the vehicles and lubricants:

THUS IT IS ESSENTIAL TO USE ONLY ENGINE LUBRICANTS WHICH ARE APPROVED AND RECOMMENDED BY THE MANUFACTURER.

SPECIAL FEATURES

Some of your vehicle's vital components have specific servicing schedules.

The airbags and the pretensioning seat belts must be replaced every 10 years.

The brake fluid must be replaced every 40 000 miles (60 000 km) or every 2 years.

The pollen filter must be checked during each regular service at the PEUGEOT dealer.

Timing belt replacement: consult a PEUGEOT dealer.

Note: the coolant does not need to be changed.

Arduous conditions of use

If the vehicle is used in certain particularly arduous conditions:

- **Continuous door-to-door use.**
- **Town use (e.g. taxi).**
- **Repeated short journeys, with the engine cold in low temperatures.**

Or in long stays in the following conditions:

- Hot countries with temperatures often above 30° C.
- Cold countries with temperatures often below minus 15° C.
- Countries with a dusty atmosphere.
- Countries whose lubricants or fuels do not conform to our recommendations.

It is necessary to follow an 'Arduous conditions' service schedule, which includes special operations and shorter service intervals:

- Every 12 000 miles (20 000 km) or every year for petrol vehicles.
- Every 6 000 miles (10 000 km) or every year for indirect injection diesel vehicles.

SERVICE LEVELS









Each vehicle has its own servicing cycle, based upon the engine type.

This cycle consists in alternating 3 types of service A, B and C, intermediate visits, and a few additional operations depending on your vehicle; these correspond to key stages in the life of your 106.

Your dealer will advise you of the type and content of the next service due, when the first service is carried out and at each subsequent service.

THE MAINTENANCE CYCLE FOR YOUR PETROL 106

Service every 20 000 miles (30 000 km) or 2 years

MILES (KM)	20 000 (30 000)/ 100 000 (150 000)	40 000 (60 000)/ 120 000 (180 000)	60 000 (90 000)/ 140 000 (210 000)	80 000 (120 000)/ 160 000 (240 000)				
1st service at 6 000 miles* (10 000 km) or 6 months* This is necessary in order to benefit from the warranty.								

Brake fluid replacement every 2 years or every 40 000 miles (60 000 km).

These services are carried out with **synthetic based** oil; Fuel **Economy oil or synthetic** oil may also be used.



















Intermediate top-up visit incorporated in the fixed services.

* Whichever comes first

PEUGEOT MAINTENANCE

THE MAINTENANCE CYCLE FOR YOUR 106 DIESEL

Service every 10 000 miles (15 000 km) or 2 years

MILES (KM)	10 000 (15 000) / 90 000 (135 000)	20 000 (30 000) / 100 000 (150 000)	30 000 (45 000) / 110 000 (165 000)	40 000 (60 000) / 120 000 (180 000)				
1st service at 6 000 miles* (10 000 km) or 6 months* This is necessary in order to benefit from the warranty.								
	50 000 (75 000) / 130 000 (195 000)	60 000 (90 000) / 140 000 (210 000)	70 000 (105 000) / 150 000 (225 000)	80 000 (120 000) / 160 000 (240 000)				
								

Brake fluid replacement every 2 years or 40 000 miles (60 000 km)

These services are carried out with **synthetic based oil**; **Fuel Economy oil** or **synthetic oil** may also be used.



Intermediate top-up visit incorporated in the fixed services.

* Whichever comes first

PEUGEOT SERVICING LEVELS A, B AND C

Operations	Description of operations for 1st service	Services	Level			
			A	B	C	Intermediate visit
DRAIN AND REFILL	- Engine drain and refill.		●	●	●	
	- Fuel filter bleeding (Diesel).	●	●	●	●	
REPLACEMENT	- Oil filter.		●	●	●	
	- Fuel filter (Petrol).			●	●	
	- Fuel filter element (Diesel).			●	●	
	- Air filter element.				●	
	- Spark plugs (Petrol).			●	●	
LEVEL	- Engine oil (check + top up).	●				●
	- Manual gearbox oil (check + top up).	●		●	●	
	- Battery (check + top up) if plug is removable.		●	●	●	
	- Front/rear windscreen wash (check + top up).	●	●	●	●	●
	- Coolant (check + top up).	●	●	●	●	●
	- Brake fluid (check + top up).	●	●	●	●	
	- Power steering fluid (check + top up according to specification).	●	●	●	●	
CHECK	- Operation of lights and indicators.	●	●	●	●	
	- Condition of glass, headlamp and light lenses and mirrors.		●	●	●	
	- Horn.		●	●	●	
	- Windscreen washer jets.		●	●	●	
	- Condition of wiper blades.		●	●	●	
	- Condition and tension of ancillary drive belts.		●	●	●	
	- Handbrake.		●	●	●	
	- Condition of hydraulic circuits (hoses and covers), check for leaks.		●	●	●	
	- Condition of rubber boots and gaiters.	●	●	●	●	
	- Brake pad wear.		●	●	●	○
	- Clearances, hubs, rods, ball joints, flexible mountings.				●	
	- Sealing of dampers.				●	
	- Wear of rear linings.				●	
	- Condition and pressure of tyres (including spare wheel).	●	●	●	●	
	- Emission control check according to current legislation (Petrol).	●	●	●	●	
	- Smoke opacity (Diesel).	●		●	●	
	- Pollen filter check (according to specification).		●	●	●	○
- Visual check of the whole vehicle by a PEUGEOT dealer.	●				●	
ROAD TEST			●	●	●	

● : All driving conditions

○ : Arduous conditions



TRADE NAMES OF APPROVED AND RECOMMENDED LUBRICANTS IN EUROPE(1)



ULTRA 10W 40 ULTRA 5W 30* ULTRON 5W 40 ULTRON 0W 30	ULTRA DIESEL 10W 40 ULTRA 5W 30* ULTRON DIESEL 5W 40		ACTIVA DIESEL 7000 10W 40 ACTIVA DIESEL 9000 5W 40 ACTIVA 9000 5W 30* QUARTZ DIESEL 7000 10W 40 QUARTZ 9000 5W 40 QUARTZ 9000 5W 30*	ACTIVA 7000 10W 40 ACTIVA 9000 5W 40 ACTIVA 9000 5W 30* QUARTZ 7000 15W 50 QUARTZ 7000 10W 40 QUARTZ 9000 0W 40 QUARTZ 9000 5W 40
● ● ● ●	● ● ●	(F)	● ● ●	● ● ●
● ● ● ●	● ● ●	(B) (L)	● ● ●	● ● ● ●
● ● ● ●	● ● ●	(NL)	● ● ●	● ● ● ●
● ● ● ●	● ● ●	(DK) (S)	● ● ●	● ● ● ●
● ● ● ●	● ● ●	(SF)	● ● ●	● ● ● ●
● ● ● ●	● ● ●	(GB) (IRL)	● ● ●	● ● ● ●
● ● ● ●	● ● ●	(GR)	● ● ●	● ● ● ●
● ● ● ●	● ● ●	(A)	● ● ●	● ● ● ●
● ● ● ●	● ● ●	(D)	● ● ●	● ● ● ●
● ● ● ●	● ● ●	(CH)	● ● ●	● ● ● ●
● ● ● ●	● ● ●	(I)	● ● ●	● ● ● ●
● ● ● ●	● ● ●	(N)	● ● ●	● ● ● ●
● ● ● ●	● ● ●	(P)	● ● ●	● ● ● ●
● ● ● ●	● ● ●	(E)	● ● ●	● ● ● ●
P E T R O L	D I E S E L		D I E S E L	P E T R O L

(1) Minimum quality level: petrol: ACEA A3 and API SH/SJ ; Diesel ACEA B3 and API CF/CD - ACEA = Association des Constructeurs Européens Automobiles (Association of European Automobile Manufacturers) - API = American Petroleum Institute.
 If oil is used which does not conform to the ACEA A3-B3 standards, this requires the "Arduous conditions" servicing schedule to be followed, which involves shorter intervals between services
 * This Energy Saving oil may only be used in engines specifically designed for it (from 2000 Model Year).

Recommendations for approved lubricants

The oils which appear in the table opposite are suitable for most purposes.

The diagram opposite states the optimum range of viscosity depending on the temperatures at which the oils are to be used.

It is also possible to use synthetic oils of 'superior quality'.

In the absence of semi-synthetic or synthetic oils, oils of API SH/SJ quality (for petrol engines), or CD/CF quality (for diesel engines) may be used by following the 'Arduous Conditions' maintenance schedule which specifies shorter intervals.

Do not hesitate to ask for advice from a Peugeot dealer to maintain driving pleasure and to minimise the maintenance cost of your vehicle.

For countries outside Europe, please contact a local PEUGEOT dealer.

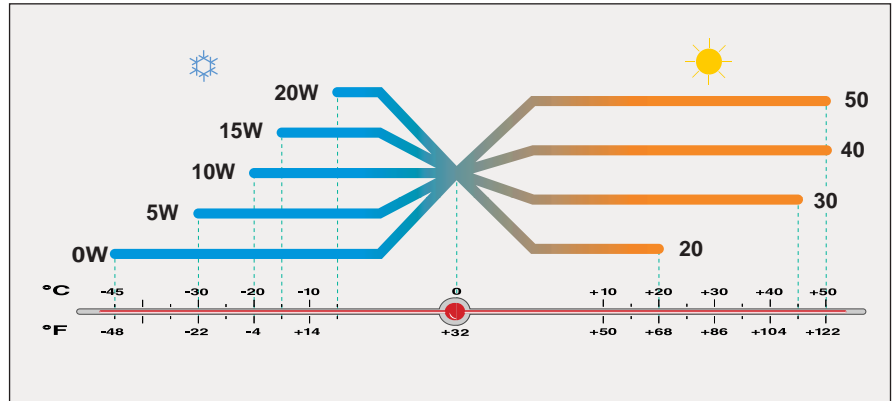

Manual gearbox	ESSENTIAL ESSO GEAR OIL BV 75W 80 PR 9736.41	ESSENTIAL TOTAL TRANSMISSION BV 75W-80
Power steering	ESSO ATF D PR 9730.94	TOTAL FLUIDE AT42

Other approved products

Brake fluid	PEUGEOT DOT4
Coolant	PROCOR TM108 / GLYSANTIN G33 or REVKOGEL 2000 ESSENTIAL Protection to minus 35 °C

INSTRUMENTS AND CONTROLS

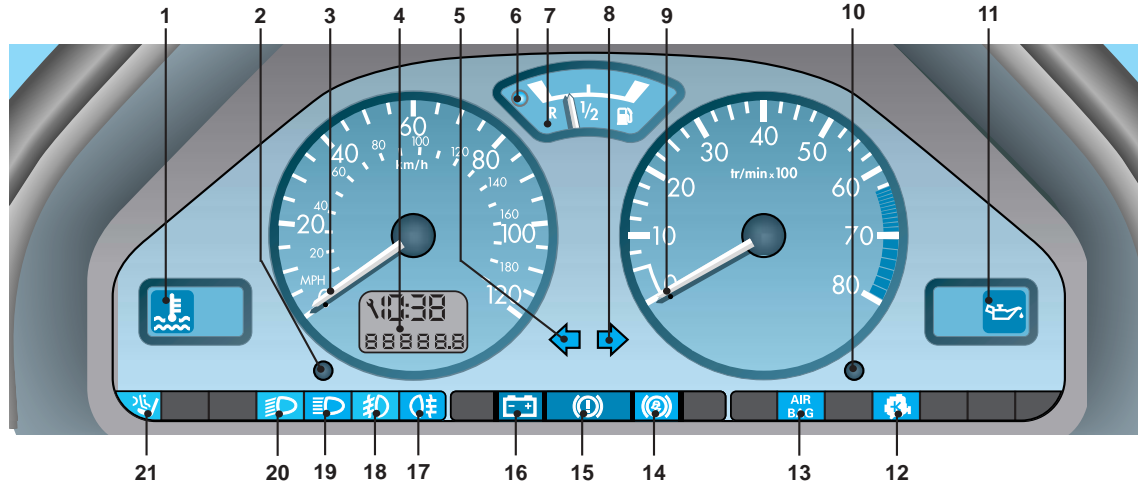
**Instrument panel (Petrol)**

- 1 - Maximum coolant temperature
- 2 - Display control:
 - total distance display
 - trip recorder - trip recorder reset
 - service indicator
- 3 - Speedometer
- 4 - Display:
 - digital clock
 - service indicator
 - total distance
 - trip recorder
- 5 - Left-hand indicator

- 6 - Low fuel level
- 7 - Fuel gauge
- 8 - Right-hand indicator
- 9 - Rev. counter
- 10 - Clock adjustment, lighting rheostat
- 11 - Oil pressure
- 12 - Engine autodiagnosics* (petrol)
- 13 - Front* and side** airbag warning light and passenger airbag disarm*
- 14 - ABS* (Anti-lock Braking System)
- 15 - Handbrake, low brake fluid level and engine not running

- 16 - Battery charge
- 17 - Rear fog lamp
- 18 - Front fog lamps*
- 19 - Main beam
- 20 - Dipped beam
- 21 - Passenger airbag disarm

* According to specification or country.

** According to model.

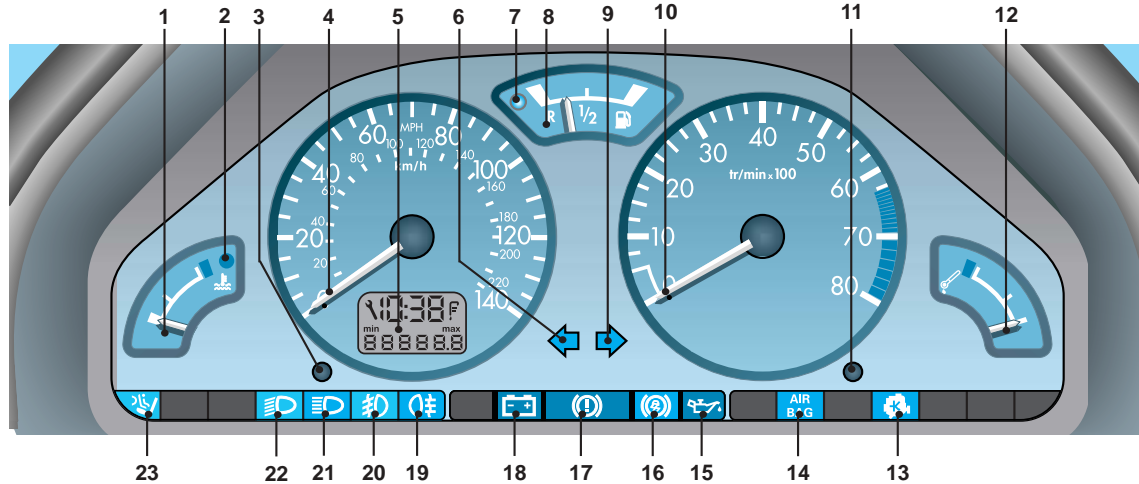

Instrument panel (Petrol)

- 1 - Coolant temperature gauge
- 2 - Maximum coolant temperature
- 3 - Display control:
 - total distance display
 - trip recorder - trip recorder reset
 - service indicator
- 4 - Speedometer
- 5 - Display:
 - digital clock
 - service indicator
 - oil level gauge
 - total distance
 - trip recorder

- 6 - Left-hand indicator
- 7 - Low fuel level
- 8 - Fuel gauge
- 9 - Right-hand indicator
- 10 - Rev. counter
- 11 - Clock adjustment, lighting rheostat
- 12 - Oil temperature gauge
- 13 - Engine autodiagnosics* (petrol)
- 14 - Front* and side** airbag warning light and passenger airbag disarm*
- 15 - Oil pressure

- 16 - ABS* (Anti-lock Braking System)
- 17 - Handbrake, low brake fluid level and engine not running
- 18 - Battery charge
- 19 - Rear fog lamp
- 20 - Front fog lamps*
- 21 - Main beam
- 22 - Dipped beam
- 23 - Passenger airbag disarm

* According to specification or country

** According to model

INSTRUMENTS AND CONTROLS

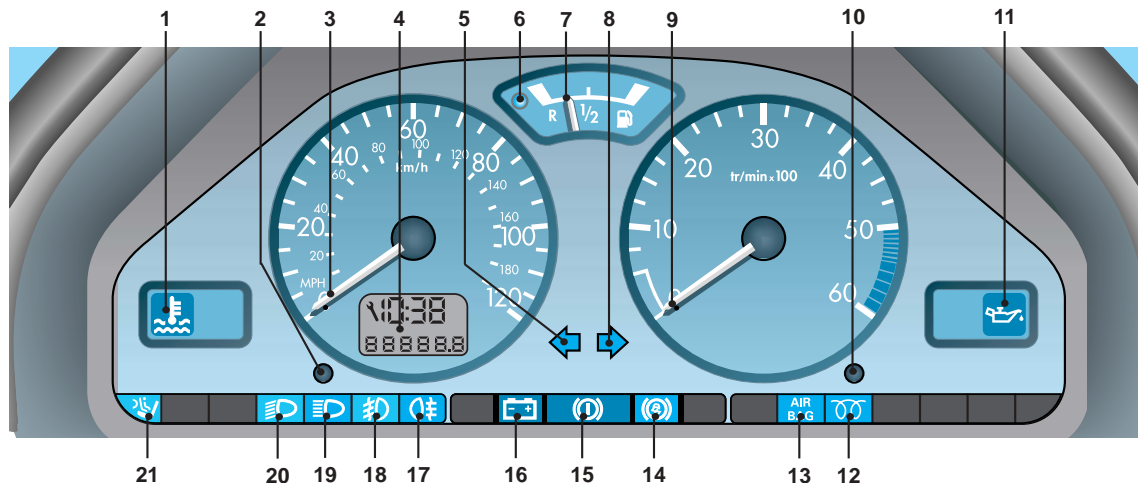
**Instrument panel (Diesel)**

- 1 - Maximum coolant temperature
- 2 - Display control:
 - total distance display
 - trip recorder - trip recorder reset
 - service indicator
- 3 - Speedometer
- 4 - Display:
 - digital clock
 - service indicator
 - total distance
 - trip recorder
- 5 - Left-hand indicator

- 6 - Low fuel level
- 7 - Fuel gauge
- 8 - Right-hand indicator
- 9 - Rev. counter
- 10 - Clock adjustment, lighting rheostat
- 11 - Oil pressure
- 12 - Pre-heat (diesel)
- 13 - Front* and side** airbag warning light and passenger airbag disarm*
- 14 - ABS* (Anti-lock Braking System)
- 15 - Handbrake, low brake fluid level and engine not running

- 16 - Battery charge
- 17 - Rear fog lamp
- 18 - Front fog lamps*
- 19 - Main beam
- 20 - Dipped beam
- 21 - Passenger airbag disarm

* According to specification or country.

** According to model.

Warning lamps



Diesel engine pre-heat

Wait until the warning lamp goes out then operate the starter. On some models the warning lamp will not light when the engine is hot.



Battery charge warning lamp

Indicates either:

- faulty operation of the charging circuit, or
- loose battery or starter terminals, or
- broken or slack alternator belt, or
- a faulty alternator.

Consult a PEUGEOT dealer.

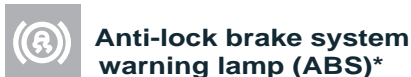

Anti-lock brake system warning lamp (ABS)*

Indicates faulty ABS operation.

The vehicle does, however, retain conventional braking.

Consult a PEUGEOT dealer.



Handbrake and brake fluid level warning lamp

Indicates either:

- that the engine is not running,
- that the handbrake is on or has not been released correctly (engine running),
- an excessive drop in the brake fluid level (engine running and handbrake released).

Note : with the engine running and the handbrake off, if the warning light remains lit then you must stop. Consult a PEUGEOT dealer.

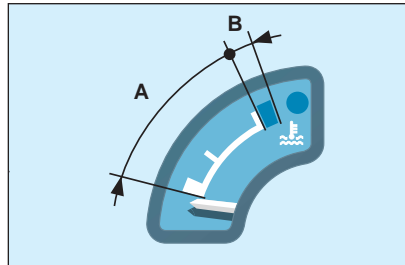

Coolant temperature gauge

- Needle in zone **(A)**: temperature correct
- Needle in zone **(B)**: the coolant temperature is too high



High coolant temperature warning lamp

It is essential to stop.

Indicates too high a temperature, caused by:

- a fan malfunction. Check the fuses and replace them if necessary,
- a coolant leak; the cooling system is pressurised, turn the cap to the 1st notch, or* unscrew the cap two turns, to let the pressure drop before topping up the level,
- a coolant pump malfunction.



Low engine oil pressure

It is essential to stop.

Indicates either:

- insufficient engine oil pressure, or
 - lack of oil in the lubrication system.
- Top up the oil level if necessary.
Consult a PEUGEOT dealer.



Low fuel level warning

Indicates that the quantity of fuel remaining is less than 1 gallon [5 litres] (Tank capacity approximately 10 gallons [45 litres]).

AIR
BAG

Front and side* airbags

If the passenger airbag is armed or if your vehicle is not fitted with a passenger airbag, the warning light comes on for 6 seconds when the ignition is switched on.



Front airbag disarmed

If the passenger airbag is disarmed, the indicator light remains on. In all cases, if the warning light flashes, contact a PEUGEOT dealer.



Engine auto-diagnostics warning light*

It comes on each time the ignition is switched on.

If it comes on with the engine running it indicates a malfunction in the injection, ignition or emission control system. If your vehicle is fitted with a catalytic converter, there is a risk of damage to it.

Contact a PEUGEOT dealer rapidly.

Oil temperature gauge*

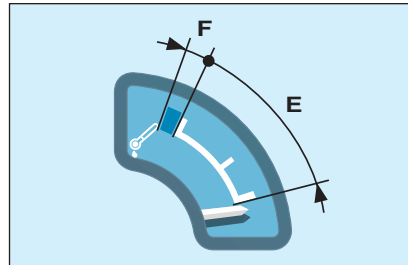

- If the needle is in zone **E**, the temperature is correct.
- If the needle is in zone **F**, the temperature is too high. To lower the temperature of the oil, reduce your speed.

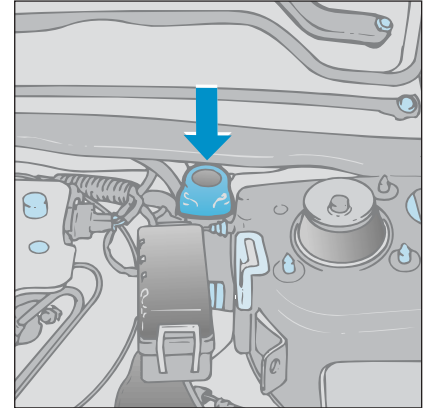

Fuel supply cut-off*

If there is a major collision, a device switches off the supply of fuel to the engine.

To re-establish the supply to the engine, press the button.

* According to specification



Low fuel level warning

Indicates that the quantity of fuel remaining is less than 1 gallon [5 litres] (Tank capacity approximately 10 gallons [45 litres]).

AIR
BAG

Front and side* airbags

If the passenger airbag is armed or if your vehicle is not fitted with a passenger airbag, the warning light comes on for 6 seconds when the ignition is switched on.



Front airbag disarmed

If the passenger airbag is disarmed, the indicator light remains on. In all cases, if the warning light flashes, contact a PEUGEOT dealer.



Engine auto-diagnostics warning light*

It comes on each time the ignition is switched on.

If it comes on with the engine running it indicates a malfunction in the injection, ignition or emission control system. If your vehicle is fitted with a catalytic converter, there is a risk of damage to it.

Contact a PEUGEOT dealer rapidly.

Oil temperature gauge*

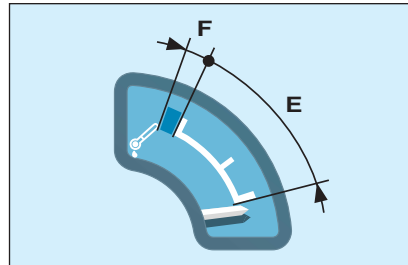

- If the needle is in zone **E**, the temperature is correct.
- If the needle is in zone **F**, the temperature is too high. To lower the temperature of the oil, reduce your speed.

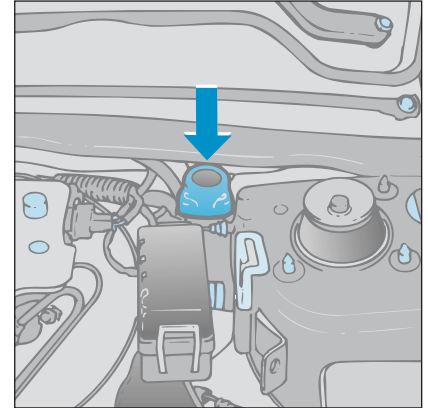

Fuel supply cut-off*

If there is a major collision, a device switches off the supply of fuel to the engine.

To re-establish the supply to the engine, press the button.

* According to specification

Instrument panel display

When the ignition is switched on, this display shows in turn, the following information:

- digital clock,
- service indicator,
- oil level indicator,*
- total distance.

Engine oil level

When the ignition is switched on, engine not running, the service indicator is displayed for a few seconds, then the engine oil level is indicated for approximately 10 seconds.



Maximum



Minimum

Check the level with the dipstick and top it up. The figure shown is only correct if the vehicle has been on stable, level ground, with the engine stopped, for 10 minutes.



No oil

When the LEDs flash, it is essential to top up the oil to the correct level, otherwise the engine will be damaged.



Total distance and trip recorder

One brief press on button **A** changes the display between total distance and the trip recorder.



Resetting the trip recorder to zero

A long press on the button resets the trip recorder to zero.

* According to specification

SERVICE INDICATOR

This is a reminder of when the next service is due in accordance with the manufacturer's maintenance schedule.

Operation

When the ignition is switched on the display shows the distance remaining (rounded figures) before the next service is due.

Example: 4800 miles remain before the next service is due. For five seconds after the ignition is switched on, the display shows:

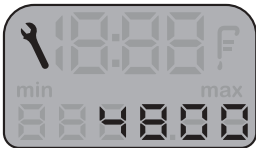

5 seconds after switching on the ignition the display resumes normal operation and shows the total and trip distances.



When the distance remaining before the next service is less than 500 miles.

Example: 450 miles remain before the next service is due.

For five seconds after the ignition is switched on, the display shows:



5 seconds after switching on the ignition the display resumes normal operation. This indicates that a service should be carried out shortly:



When a service is overdue.

For five seconds after the ignition is switched on, the service symbol and the excess distance flash.

Example: the service is overdue by 300 km. The vehicle should be serviced very soon.

For 5 seconds after the ignition is switched on the display shows:



5 seconds after switching on the ignition the display resumes normal operation.



Service intervals

If your vehicle is used in certain particularly difficult conditions it is necessary to follow the "Arduous conditions" servicing schedule, which involves shorter intervals between services (see the Warranty and Maintenance Record booklet).

Comment: If the time limit between two services is reached before the relevant mileage limit, the service spanner symbol will light up and the display will show 0.

To change the service interval

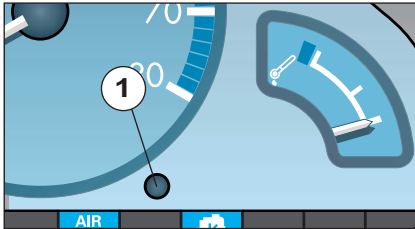

- Switch off the ignition.
- Press and hold button 1.

- Switch on the ignition.
- Release the button straight away.
- The service interval is displayed.
- Each time button 1 is pressed briefly, the service intervals are alternated.

Example



- When the required service interval is displayed, press button 1 for 10 seconds to confirm (the selected service interval flashes for 10 seconds).

Release the button to confirm when the display stops flashing.

Reset to zero

Your PEUGEOT dealer will carry out this operation after each service.

However, if you carry out your service yourself, the zero reset procedure is as follows:

- switch off the ignition,
- press and hold button 1,
- switch on the ignition,
- keep button 1 pressed for 10 seconds,

the display indicates [= 0] and the service spanner symbol disappears.

Service intervals

If your vehicle is used in certain particularly difficult conditions it is necessary to follow the "Arduous conditions" servicing schedule, which involves shorter intervals between services (see the Warranty and Maintenance Record booklet).

Comment: If the time limit between two services is reached before the relevant mileage limit, the service spanner symbol will light up and the display will show 0.

To change the service interval

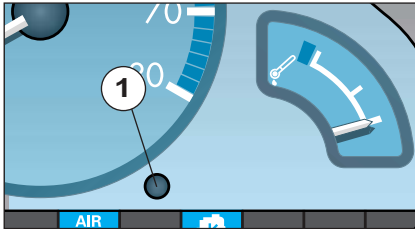

- Switch off the ignition.
- Press and hold button 1.

- Switch on the ignition.
- Release the button straight away.
- The service interval is displayed.
- Each time button 1 is pressed briefly, the service intervals are alternated.

Example



- When the required service interval is displayed, press button 1 for 10 seconds to confirm (the selected service interval flashes for 10 seconds).

Release the button to confirm when the display stops flashing.

Reset to zero

Your PEUGEOT dealer will carry out this operation after each service.

However, if you carry out your service yourself, the zero reset procedure is as follows:





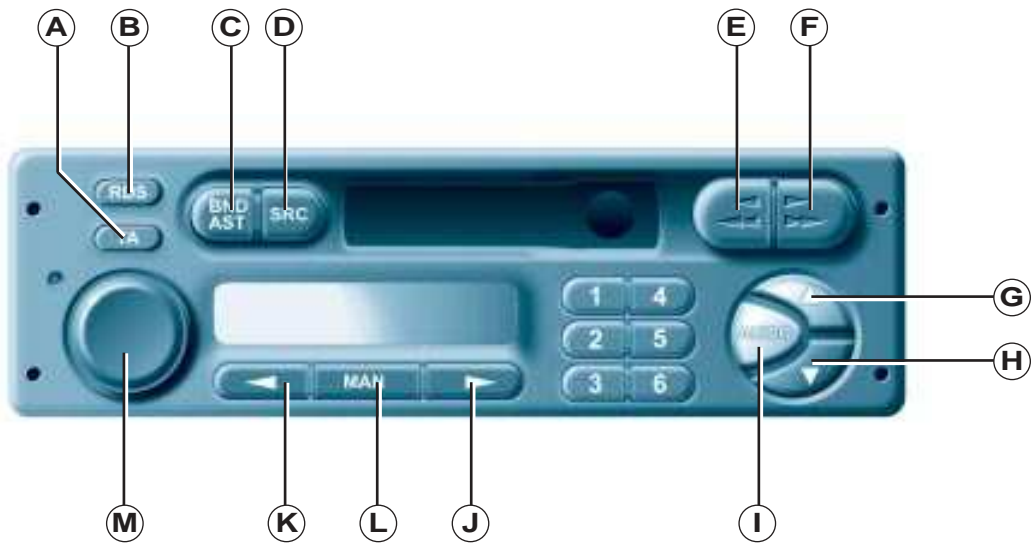

- switch off the ignition,
- press and hold button 1,
- switch on the ignition,
- keep button 1 pressed for 10 seconds,

the display indicates [= 0] and the service spanner symbol disappears.

YOUR 106 IN DETAIL

AUDIO RB1



Button		Function
A	TA	Traffic information priority on/off.
B	RDS	RDS on/off. Press for more than 2 seconds: regional following mode on/off.
C	BND/AST	Selection of wavebands FM1, FM2, FM3, AM. Press for more than 2 seconds: autostore, automatic storing of stations.
D	SRC	Source selection; radio, cassette or CD*. Press for more than 2 seconds: CD* shuffle.
E		Press fully: cassette fast rewind.
F		Press fully: cassette fast forwards.
E + F		Press half-way: reverses the direction of play of the cassette. Press fully: ejects the cassette.
G		Increase the audio setting.
H		Decrease the audio setting.
I	AUDIO	Selects the bass, treble, loudness and sound distribution.
J		Higher frequency automatic search. Selection of next CD* track.
K		Lower frequency automatic search. Selection of previous CD* track.
L	MAN	Manual/automatic operation of button J and K .
M		Audio system on/off. Volume adjustment.
1 to 6		Selects a stored station. Press for more than 2 seconds: stores a station. Selects a CD*.

* Available as an accessory.

GENERAL FUNCTIONS



On / off

With the ignition key in the ACCESSORIES or IGNITION position, press the "**M**" button to switch the set on or off.

ANTI-THEFT SYSTEM

The first time you use the set following disconnection of the set or the battery, you must enter the confidential code which was given to you on handover of your vehicle.

Entering the code

Switch the set on.

The display shows "**CODE**" then the set changes over to code request mode and "- - - -" is displayed.

Enter your **four-digit** code number using buttons "**1**" to "**6**".

For example : if your code is 5345 press buttons "**5**", "**3**", "**4**" and "**5**" in turn.

When the fourth number has been entered correctly, the radio starts automatically.

Error in entering the code

If an error is made when entering one of the first three digits, do not continue the operation and switch off the radio to prevent blocking it.

Each incorrect code entry will result in the set being blocked for a period of from 5 seconds to 30 minutes, after the 7th incorrect entry.

To unblock the set, leave it switched on during the waiting period. When "- - - -" is displayed, you can enter the code again.

If the set is switched off during the waiting period, this waiting period will restart when the set is switched on again.

After 14 incorrect code entries, the radio will be permanently blocked and the message "**END**" will be displayed.

ADJUSTING THE SOUND

Adjusting the volume

Turn the "**M**" button to increase or decrease the volume of the set.

If the radio overheats, the volume will reduce.

Note: If you have a car-phone fitted with a "**mute**" signal output connected to the set, the set will automatically change to "**mute**" when the car-phone is used.



AUDIO SETTINGS

Press the “**AUDIO**” button several times in succession to access the bass (**BASS**), treble (**TREB**), loudness (**LOUD**), fader (**FAD**) and balance (**BAL**).

Exit from audio mode is automatic after a few seconds, without pressing any button or by pressing the “**AUDIO**” button after adjusting the balance.

Note: bass and treble settings are specific to each source. It is possible to set them differently for radio, cassette and CD.

Bass setting

When “**BASS**” is displayed, press the “**G**” or “**H**” buttons to vary the setting.

- “**BASS –9**” for a minimum bass setting,
- “**BASS 0**” for a normal position,
- “**BASS +9**” for a maximum bass setting.

Treble setting

When “**TREB**” is displayed, press the “**G**” or “**H**” buttons to vary the setting.

- “**TREB –9**” for a minimum treble setting,
- “**TREB 0**” for a normal position,
- “**TREB +9**” for a maximum treble setting.

Adjusting the loudness

This function automatically emphasises bass and treble tones when the volume is low.

Press the “**G**” or “**H**” buttons to switch this function on or off.

Setting the front/rear sound distribution (Fader)

When “**FAD**” is displayed, press the “**G**” or “**H**” buttons to vary the setting.

The “**G**” button increases the volume at the front.

The “**H**” button increases the volume at the rear.

This function can be deactivated by pressing buttons “**M**” and “**I**” simultaneously.

Setting the right/left sound distribution (Balance)

When “**BAL**” is displayed, press the “**G**” or “**H**” buttons to vary the setting.

The “**G**” button increases the volume on the right-hand side.

The “**H**” button increases the volume on the left-hand side.

RADIO

Notes on radio reception

Your radio is subject to phenomena which do not affect domestic sets. Both MW/LW and FM reception are subject to various forms of interference which are no reflection on the quality of your set, but are due to the nature of the signals and the way in which they are transmitted.

On MW/LW, interference may be noticed when passing underneath high voltage power lines or bridges or through tunnels.

On FM, interference may be the result of increasing distance from the transmitter, reflection of the signal by obstacles (mountains, hills, buildings etc), or of being in an area which is not covered by a transmitter.



Selecting the radio

Press the "SRC" button, until the radio is selected.



Selecting a waveband

By short presses on the "BND/AST" button, you can select the FM1, FM2, FM3 and AM wavebands.



Automatic station search

Briefly press button "J" or "K" to search for the station immediately above or below. By continuing to press the button in the direction selected, you will obtain continuous scrolling of the frequency.



The scrolling stops at the first station found as soon as you release the button.

If the TA traffic programme is selected, only stations broadcasting this type of programme are selected.

Searching for a station occurs first in "LO" sensitivity (selection of the most powerful transmitters) during scanning of the waveband, then in "DX" sensitivity (selection of the weakest and most distant transmitters).

Manual station search

Press the "MAN" button.

Briefly press button "J" or "K" respectively to increase or reduce the frequency displayed.

By continuing to press the button in the direction selected, you will obtain continuous scrolling of the frequency.

Scrolling stops as soon as you release the button.

Pressing the "MAN" button again returns you to automatic station search.



Manual storing of stations in the memory

Select the station required.

Press for more than two seconds one of the buttons “1” to “6”.

The sound stops then becomes audible again, confirming that the station has been stored in memory.

Automatic storing of FM stations in the memory (autostore)

Press the “**BND/AST**” button for more than two seconds, to automatically store the 6 stations with the strongest signal in FM. These stations are stored in the FM3 waveband.

– If it is not possible to find 6 stations, the remaining memories are empty.

Recalling stations stored in the memory

For each waveband, briefly pressing the buttons “1” to “6” recalls the corresponding stored station.



RDS FUNCTION

Using the RDS (Radio Data System) function on FM

RDS allows you to continue to listen to the same station, whatever frequency it is using for the region you are going through.

Switch the function on or off by briefly pressing the “**RDS**” button.

RDS station following

The display indicates the name of the station selected. The radio is continually searching for the station which has the best reception and which is transmitting the same programme.



Traffic information programmes

Press the "TA" button to switch the function on or off.

Any traffic information flash will be given priority, whatever source you are listening to (radio, cassette or CD).

If you wish to interrupt a message, press the "TA" button; this switches off the function.

Note: the volume of the traffic information announcements is independent of the volume of normal radio listening. You can adjust it using the volume button. The setting will be stored and will be used when the next messages are broadcast.

While traffic information is being broadcast, the display will alternately show "TRAFFIC" and the name of the station.

When the station selected cannot broadcast traffic information, the display shows "NO TA".



Regional following mode (REG)

When they are part of a network, certain stations broadcast regional programmes in the various areas they serve.

With regional following mode you can keep listening to the same programme.

To do this press the "RDS" button for more than two seconds to switch this function on or off.



CASSETTE

Selecting cassette mode



When a cassette is inserted, the cassette player will start automatically.
If a cassette is already inserted, press the "**SRC**" button until the cassette is selected.

Ejecting the cassette



Fully press both buttons "**E**" and "**F**" to eject the cassette from the player.

Direction of play

The player will play sides 1 and 2 of the cassette alternately, by automatically reversing the direction of play at the end of a side.

To manually reverse the direction of play, press both buttons "**E**" and "**F**" part way.

Fast forward/rewind



Fully press one of the buttons "**E**" or "**F**" to fast forward or fast rewind the cassette. At the end of the fast forward/rewind, the set plays the current side.

Note: During fast forwards or rewind of a cassette, the audio system will automatically play the last radio station.

Recommendations for using cassettes

- Use good quality cassettes.
- Avoid use of cassettes which play for longer than 90 minutes.
- Never expose the cassettes to heat or the direct rays of the sun.
- Re-tighten the tape if necessary before introducing the cassette in the player.
- Clean the playing head regularly with a damp type cleaning cassette.

CD MULTI-CHANGER (Available as an accessory)



Selecting the CD changer

Press the “**SRC**” button until the CD changer is selected.

Selecting a disc

Press a button from “**1**” to “**6**” to select the corresponding disc.



Selecting a track

Press button “**J**” to select the next track.



Press button “**K**” to return to the start of the current track or to select the previous track.



Accelerated play

Press the “**MAN**” button.

Keep button “**J**” or “**K**” pressed for forwards or backwards accelerated play.

Accelerated play stops as soon as you release the button.

Buttons “**J**” and “**K**” resume the “track selection” function when the “**MAN**” button is pressed again.

Shuffle (RAND)









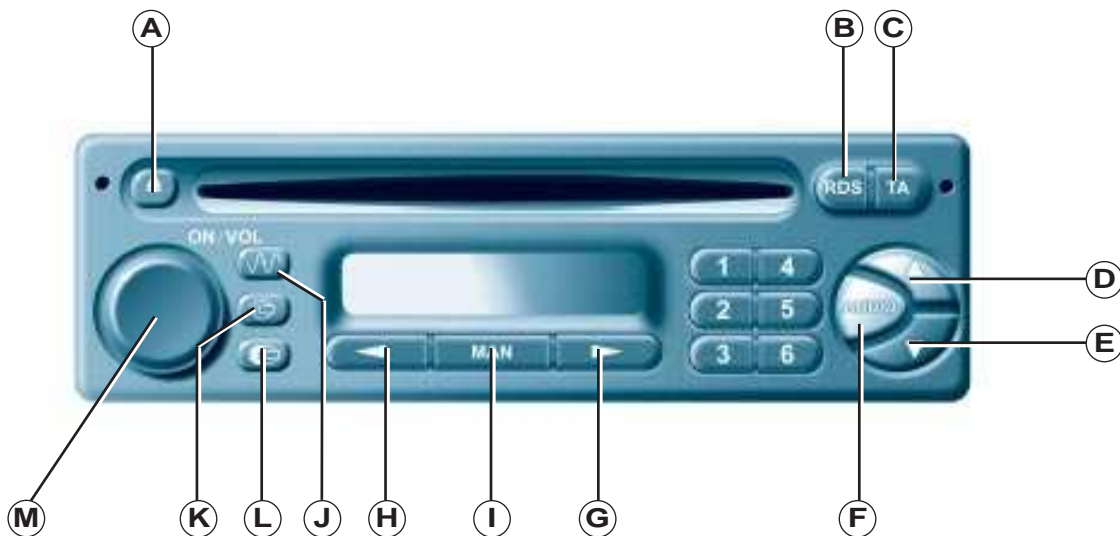

When the CD multi-changer is selected, keep the “**SRC**” button pressed for two seconds. The tracks will be played in random sequence. Pressing the “**SRC**” button again for two seconds returns you to normal play.

Note : Do not use blank CDs as these could damage your player.

YOUR 106 IN DETAIL

AUDIO RD1



Button		Function
A		Ejection of the CD.
B	RDS	RDS function on/off. Press for more than 2 seconds: regional station following on/off.
C	TA	Traffic information priority on/off. Press for more than 2 seconds: PTY function on/off.
D		Increase the audio setting.
E		Decrease the audio setting.
F	AUDIO	Selects the bass, treble, loudness and sound distribution.
G		Automatic search of higher frequency. Selection of next CD track.
H		Automatic search of lower frequency. Selection of previous CD track.
I	MAN	Manual/automatic operation of buttons G and H .
J		Source selection, radio. Selection of wavebands FM1, FM2, FM3, AM. Press for more than 2 seconds: automatic storing of stations (autostore).
K		Source selection, CD. Press for more than 2 seconds: shuffle.
L		Source selection: CD player. Press for more than 2 seconds: shuffle.
M	ON/VOL	Audio system on/off.
1 to 6		Selects a stored station. Press for more than 2 seconds: stores a station. Selects a CD.

GENERAL FUNCTIONS

On / off



With the ignition key in the ACCESSORIES or IGNITION position, press the "M" button to switch the set on or off. The set can operate for 30 minutes without switching the ignition on.

ANTI-THEFT SYSTEM

The first time you use the set following disconnection of the set or the battery, you must enter the confidential code which was given to you on handover of your vehicle.

Entering the code

Switch the set on.

The display shows "CODE" then the set changes over to code request mode and "- - -" is displayed.

Enter your **four-digit** code number using buttons "1" to "6".

For example: : if your code is 5345 press buttons "5", "3", "4" and "5" in turn.

When the fourth number has been entered correctly, the radio starts automatically.

Error in entering the code

If an error is made when entering one of the first three digits, do not continue the operation and switch off the radio to prevent blocking it.

Each incorrect code entry will result in the set being blocked for a period of from 5 seconds to 30 minutes, after the 7th incorrect entry.

To unblock the set, leave it switched on during the waiting period. When "- - -" is displayed, you can enter the code again.

If the set is switched off during the waiting period, this waiting period will restart when the set is switched on again.

After 14 incorrect code entries, the radio will be permanently blocked and the message "END" will be displayed.

ADJUSTING THE SOUND

Adjusting the volume

Turn the "M" button to increase or decrease the volume of the set.

If the radio overheats, the volume will reduce.

Note: If you have a car-phone fitted with a "mute" signal output connected to the set, the set will automatically change to "mute" when the car-phone is used.



AUDIO SETTINGS

Press the “**AUDIO**” button several times in succession to access the bass (**BASS**), treble (**TREB**), loudness (**LOUD**), fader (**FAD**) and balance (**BAL**).

Exit from audio mode is automatic after a few seconds, without pressing any button or by pressing the “**AUDIO**” button after adjusting the balance.

Note: the bass and treble settings are specific to each source. It is possible to set the radio, CD, or CD multi-changer differently.

Bass setting

When “**BASS**” is displayed, press the “**D**” or “**E**” buttons to vary the setting.

- “**BASS -9**” for a minimum bass setting,
- “**BASS 0**” for a normal position,
- “**BASS +9**” for a maximum bass setting.

Treble setting

When “**TREB**” is displayed, press the “**D**” or “**E**” buttons to vary the setting.

- “**TREB -9**” for a minimum treble setting,
- “**TREB 0**” for a normal position,
- “**TREB +9**” for a maximum treble setting.

Adjusting the loudness

This function automatically emphasises bass and treble tones when the volume is low. Press the “**D**” or “**E**” buttons to switch this function on or off.

Setting the front/rear sound distribution (Fader)

When “**FAD**” is displayed, press the “**D**” or “**E**” buttons to vary the setting.

The “**D**” button increases the volume at the front.

The “**E**” button increases the volume at the rear.

This function can be deactivated by pressing buttons “**M**” and “**F**” simultaneously.

Setting the right/left sound distribution (Balance)

When “**BAL**” is displayed, press the “**D**” or “**E**” buttons to vary the setting.

The “**D**” button increases the volume on the right-hand side.

The “**E**” button increases the volume on the left-hand side.

RADIO

Notes on radio reception

Your radio is subject to phenomena which do not affect domestic sets. Both MW/LW and FM reception are subject to various forms of interference which are no reflection on the quality of your set, but are due to the nature of the signals and the way in which they are transmitted.

On MW/LW, interference may be noticed when passing underneath high voltage power lines or bridges or through tunnels.

On FM, interference may be the result of increasing distance from the transmitter, reflection of the signal by obstacles (mountains, hills, buildings etc), or of being in an area which is not covered by a transmitter.

Selecting the radio

Press the "J" button.

Selecting a waveband

By short presses on the "J" button, you can select the FM1, FM2, FM3 and AM wavebands.



Automatic station search

Briefly press button "G" or "H" to search for the station immediately above or below. By continuing to press the button in the direction selected, you will obtain continuous scrolling of the frequency.

The scrolling stops on the first station found as soon as you release the button.

If TA, traffic information programme, is selected, only stations broadcasting this type of programme are selected.

Searching for a station occurs first in "LO" sensitivity (selection of the most powerful transmitters) during scanning of the waveband, then in "DX" sensitivity (selection of the weakest and most distant transmitters).

To scan the waveband in "DX" sensitivity, press twice on button "G" or "H".



Manual station search

Press the "MAN" button.

Briefly press button "G" or "H" respectively to increase or reduce the frequency displayed.

By continuing to press the button in the direction selected, you will obtain continuous scrolling of the frequency.

Scrolling stops as soon as you release the button.

Pressing the "MAN" button again returns you to automatic station search.



Manual storing of stations in the memory

Select the station required.

Press for more than two seconds one of the buttons “1” to “6”.

The sound stops then becomes audible again, confirming that the station has been stored in memory.

Automatic storing of FM stations in the memory (autostore)

Press the “J” button for more than two seconds, to automatically store the 6 stations with the strongest signal in FM. These stations are stored in the FM3 waveband.

– If it is not possible to find 6 stations, the remaining memories are empty.

Recalling stations stored in the memory

For each waveband, briefly pressing the buttons “1” to “6” recalls the corresponding stored station.



RDS FUNCTION

Using the RDS (Radio Data System) function on FM

RDS allows you to continue to listen to the same station, whatever frequency it is using for the region you are going through.

Switch the function on or off by briefly pressing the “RDS” button.

RDS station following

The display indicates the name of the station selected. The radio is continually searching for the station which has the best reception and which is transmitting the same programme.



Traffic information programme



Press the “**TA**” button to switch the function on or off.

Any traffic information flash will be given priority, whatever source you are listening to (radio, CD or CD changer).

Note: the volume of the traffic information announcements is independent of the volume of normal radio listening. You can adjust it using the volume button. The setting will be stored and will be used when the next messages are broadcast.

While traffic information is being broadcast, the display will alternately show “**TRAFFIC**” and the name of the station. When the station selected cannot broadcast traffic information, the display shows “**NO TA**”.

Regional following mode (REG)



When they are part of a network, certain stations broadcast regional programmes in the various areas they serve.

With regional following mode you can keep listening to the same programme.

To do this press the “**RDS**” button for more than two seconds to switch this function on or off.

PTY function

This allows you to listen to stations broadcasting a specific type of programme (news, culture, sport, rock etc.).

With FM selected, press the “**TA**” button for two seconds to switch this function on or off.

To find a PTY programme:

- switch on the **PTY** function,
- briefly press button “**G**” or “**H**” to scroll down the list of the various types of programmes offered,
- when the programme of your choice is displayed, keep button “**G**” or “**H**” pressed for more than two seconds to carry out an automatic search (after an automatic search the PTY function is switched off).

In **PTY** mode the different types of programmes can be stored in memory. To do this, press down the preselection buttons “**1**” to “**6**” for more than two seconds. Recalling the type of programme stored in the memory is by a brief press on the corresponding button.



EON system

This connects stations which are part of the same network. It enables broadcasting of traffic information or a PTY programme from a station which is part of the same network as the station to which you are listening. This service is available when you have selected the TA traffic information programme or the PTY function.

COMPACT DISC

Selecting the CD as source



After inserting a disc, with the printed surface upwards, the player starts automatically. If a disc is already inserted, press the "K" button.

Ejecting a disc



Press button "A" to eject the disc from the player.

Selecting a track



Press button "G" to select the next track.



Press button "H" to return to the start of the current track or to select the previous track.

Accelerated play

Press the "MAN" button.

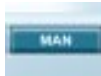

Keep button "G" or "H" pressed for forwards or backwards accelerated play.

Accelerated play stops as soon as you release the button.

Buttons "G" and "H" resume the "track selection" function when the "MAN" button is pressed again.

Shuffle (RDM)



When the CD is selected, keep the "K" button pressed for two seconds. The tracks will be played in random sequence. Pressing the "K" button again for two seconds returns you to normal play.

Note : Do not use blank CDs as these could damage your player.

EON system

This connects stations which are part of the same network. It enables broadcasting of traffic information or a PTY programme from a station which is part of the same network as the station to which you are listening. This service is available when you have selected the TA traffic information programme or the PTY function.

COMPACT DISC

Selecting the CD as source



After inserting a disc, with the printed surface upwards, the player starts automatically. If a disc is already inserted, press the "K" button.

Ejecting a disc



Press button "A" to eject the disc from the player.

Selecting a track



Press button "G" to select the next track.



Press button "H" to return to the start of the current track or to select the previous track.

Accelerated play

Press the "MAN" button.



Keep button "G" or "H" pressed for forwards or backwards accelerated play.

Accelerated play stops as soon as you release the button.

Buttons "G" and "H" resume the "track selection" function when the "MAN" button is pressed again.

Shuffle (RDM)



When the CD is selected, keep the "K" button pressed for two seconds. The tracks will be played in random sequence. Pressing the "K" button again for two seconds returns you to normal play.

Note : Do not use blank CDs as these could damage your player.

CD MULTI-CHANGER



Selecting the CD changer

Press the “L” button.

Selecting a disc

Press a button from “1” to “6” to select the corresponding disc.



Selecting a track

Press button “G” to select the next track.



Press button “H” to return to the start of the current track or to select the previous track.

Accelerated play

Press the “MAN” button.

Keep button “G” or “H” pressed for forwards or backwards accelerated play.

Accelerated play stops as soon as you release the button.

Buttons “G” and “H” resume the “track selection” function when the “MAN” button is pressed again.



Shuffle (RDM)

When the CD multi-changer is selected, keep the “L” button pressed for two seconds. The tracks will be played in random sequence. Pressing the “L” button again for two seconds returns you to normal play.

Note : Do not use blank CDs as these could damage your player.

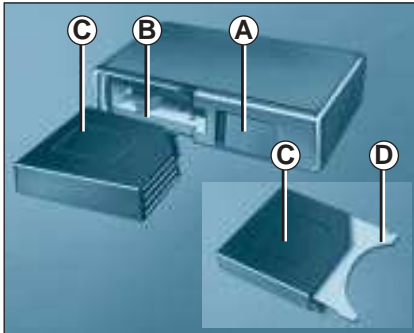
CD changer (Available as an accessory)**To insert a disc into the changer:**

- open sliding panel **A**,
- press button **B** to eject the cartridge **C**,
- open one of the six compartments of the cartridge by pulling tab **D**,
- **insert the disc with the printed face upwards and close the compartment**,
- insert the cartridge into the changer,
- close the sliding panel **A**.

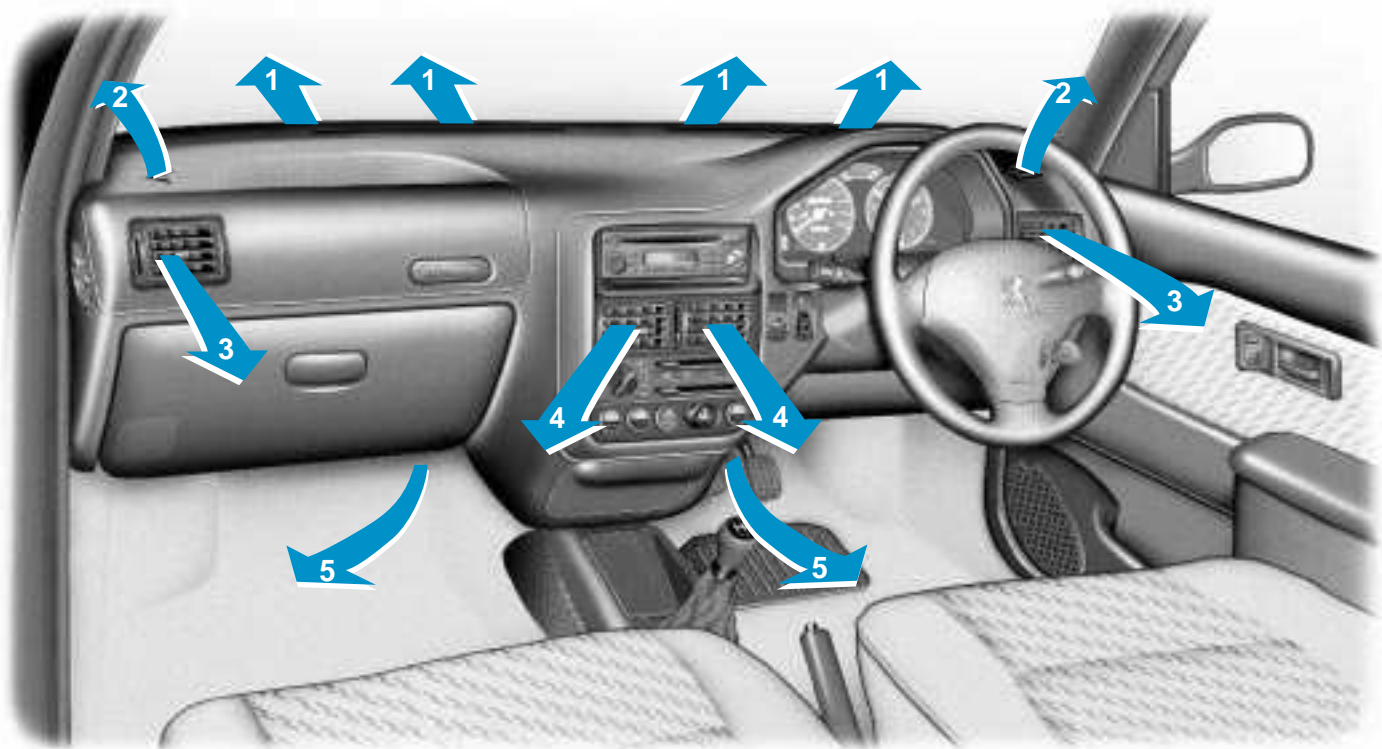

VENTILATION

- 1 - Windscreen de-icing/demisting vents.
- 2 - Front windows de-icing/demisting vents.
- 3 - Side vents.
- 4 - Centre vents.
- 5 - Air outlet to front passengers' footwell

Recommendations for use

- Adjust the airflow to ensure sufficient renewal of air in the passenger compartment.
- Select the air distribution setting that is best suited to your requirements and the climatic conditions.
- Select a temperature setting and adjust it gradually to obtain maximum comfort.



HEATING AND VENTILATION:

Location of the controls

1 - Air flow

 Turn the knob to the desired position.

To temporarily stop the entry of outside air :

- Turn the knob to position 0.
- Close the centre and side grilles.
- Place the air distribution control in the centre and side vents position.

This setting prevents the entry of unpleasant odours or dust - it must only be used in exceptional circumstances.

2 - Air distribution

 Centre and side vents.

 Occupants' feet.

 Windscreen, front windows and occupants' feet

 Windscreen and side windows.

To rapidly demist or de-ice the windscreen and side windows:

- set temperature and air flow controls to maximum position,
- set air distribution control to "windscreen and side windows",
- close the centre and side vents.

To obtain correct and thorough air distribution, ensure that:

- the exterior air grille is not obstructed,
- the air inlet vents and the air passages under the front seats are not blocked.

In summer, use the «centre and side vents» position.

In winter, in order to improve the level of comfort, use the «occupants' feet» position and for good visibility the «windscreen, front windows and occupants' feet» position.

3 - Temperature adjustment

Move the control to the left (blue zone: ambient temperature) or to the right (red zone: hot).

Air conditioning*

This function allows the temperature to be lowered in summer, and in winter, above 0°C, the demisting function to be improved.

4 - Air conditioning on/off operation:

A/C Press the switch; the indicator lamp will light.

- adjust air flow, control **1**.
- adjust air distribution, control **2**.
- adjust temperature, control **3**.

5 - Recirculation of the interior air



Press the switch. The indicator lamp will light.

- Used simultaneously with the air conditioning, it improves performance.
- Used on its own, it prevents the entry of outside air (dust, unpleasant odours) but there is a risk of misting up of the windows.

Do not operate the interior air recirculation control continuously.



- *Operate the air conditioning system for 5 to 10 minutes once or twice a month to keep it in perfect working order.*
- *If the system does not produce cold air, do not use it and contact a Peugeot dealer.*

* According to specification

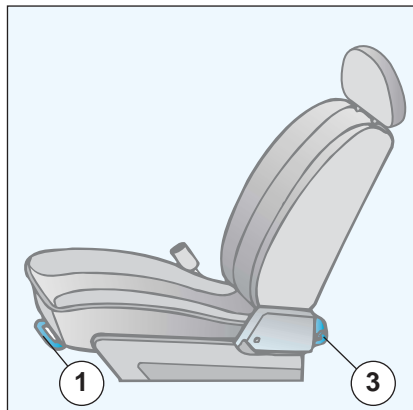

Adjustment of front seats

Forwards/backwards adjustment:

lift control 1, slide the seat, then let go to lock.

Adjustment of seat back:

push control 2 rearwards to obtain the required angle.

Access to rear seats: (3 doors)

raise control 3 or push control 2 towards the front.

Tilt the back of the seat, then pull the seat forward.

The position of the seats is memorised*. To put them back as they were before, you need only return them to the original position.

The storage compartment for the handbook and Warranty book is located under the front right-hand seat*.

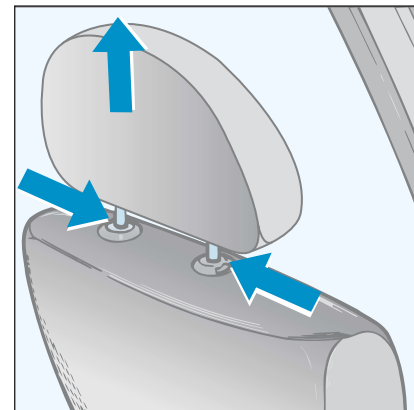
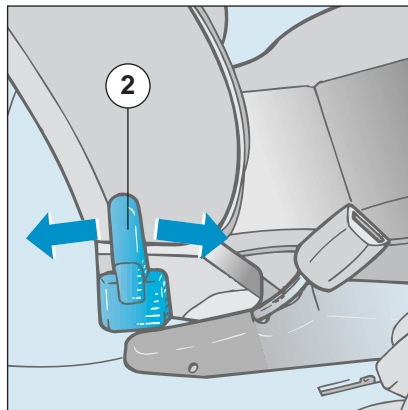

Front head restraints

Height adjustment: slide the head restraint.

The adjustment is correct when the upper edge of the head restraint is at the same height as the top of the head. This adjustment avoids excessive movement of the head rearwards, in cases of rear impact.

Adjustment of angle*: tilt the head restraint.

To remove the head restraint: position it at maximum height, press the two lugs then remove the head restraint.

Warning: never drive with the head restraints removed; they must be in place and correctly adjusted.

* According to specification

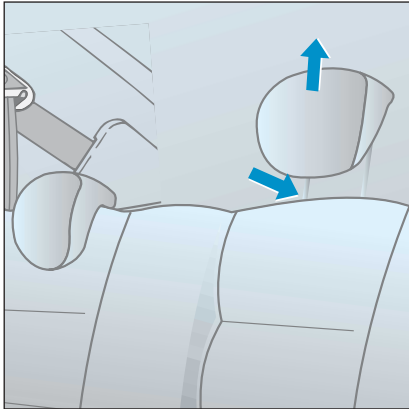

Rear head restraints*

These have one position (high) for when they are in use and another position (low) for storing. They are removable.

To lower, press the lug.

To remove, pull upwards as far as the stop and press the lug.

Warning: never drive with the head restraints removed; they must be in place and correctly adjusted.

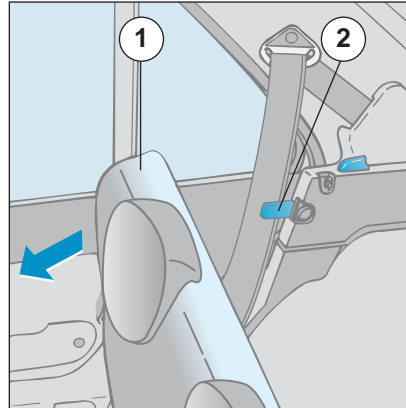

Rear seats

To tilt the seat:

- Pull the rear of the seat **1** and tilt it against the front seats.
- Place the seat-belt in the hook **2** (3-door) or on the top of the seat-back **4** (5-door).
- Unlock the seat-back by using the controls **3** on the sides.
- Tilt the seat-back **4**.

To remove the rear seat cushions, tilt the seat cushion to 45° and remove it.

To replace the seat cushion: position it on the front fixing brackets and lower it to the normal position.

When folding the rear seats, always start with the seat cushion, never the seat back (risk of damage).

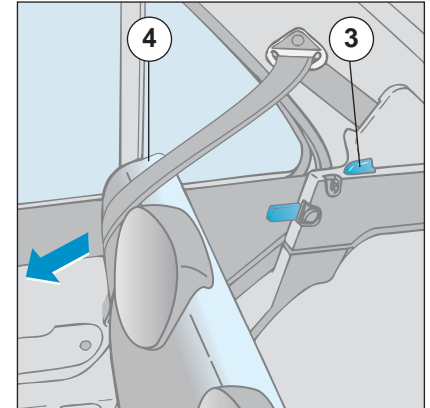

* According to specification.

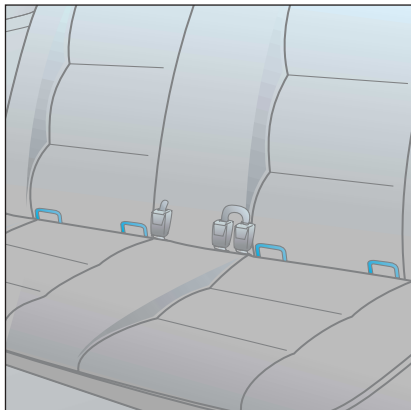

Isofix mounting*

The Isofix mountings available on the two rear seats* allow for the installation of **special child seats****, approved by UTAC for PEUGEOT vehicles and marketed within the network.

The fixings are available as an accessory and must be fitted by an approved PEUGEOT dealer.

The locks incorporated in the child seat fit onto the mounting and ensure quick, reliable and safe installation of the seats. The combined use of the seat belt is **compulsory** for a forward-facing child seat.

The forward-facing position is permitted in the rear.

For maximum safety, it is **essential** to adjust the corresponding front seat to the intermediate longitudinal position, seat back upright.

Follow the instructions for fitting the child seat in the leaflet provided when the child seat is purchased.

* According to specification.

** Available during the model year



Child seats

This was one of PEUGEOT's main criteria when designing your vehicle, however the safety of your children also depends on you.

For maximum peace of mind, please follow these simple precautions:

All children under the age of 10 are required to travel in approved child safety seats*, fitted with seat belts.

After carrying out numerous tests, PEUGEOT recommend the following systems:

Up to 9 months (up to 22 lbs. or 10 kg)

- ① «Baby Safe», a seat secured with its back to the engine and secured with a three-point seat belt, on either the front or rear seat.

From 9 months to 3 or 4 years (20 to 40 lbs. or 9 to 18 kg)

- ② «Römer Peggy» is fitted to the rear seat with a two-point (lap-belt) or three-point belt.

From 3 to 10 years of age (33 to 80 lbs or 15 to 36 kg)

- ③ «Klippan Optima» : is fitted in the rear with a three point belt (removable seatback).
 - from 33 to 55 lbs. [15 to 25 kg] : booster + seatback.
 - from 55 to 80 lbs. [25 to 36 kg] : use the booster on its own.

For maximum safety, fasten the three-point seat belts or the child seat straps keeping the slack in relation to the child's body to a minimum, even for short journeys.

To prevent the doors from opening accidentally: use the child-proof lock.

Also, do not open the rear windows more than a third.



Never leave a child in a vehicle which is exposed to the sun and has the windows closed.

To protect young children from the sun, fit sunblinds to the rear windows.

Never leave the keys in the reach of children inside the car.

Strap children into their child seats even on short journeys.

Observe the precautions concerning the passenger airbag.



* According to current legislation.

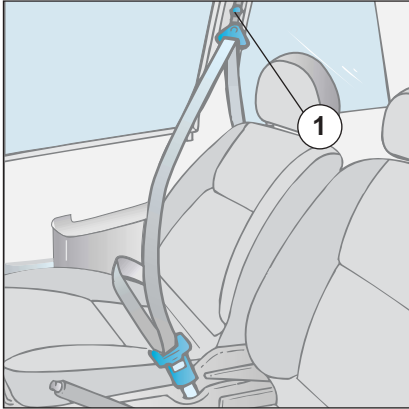

Seat belts (5-door):

To adjust the height of the front seat belts*:

Pull control 1 towards you and slide it.

To fasten the seat belts:

Pull the strap, then insert the end into the buckle.

Rear seat belts

The rear seats are fitted with two three-point inertia reel belts and a lap belt.

Pre-tensioning and force-limiting front seat belts*

Safety in the event of a front impact has been improved by the introduction of pre-tensioning and force-limiting front seat belts. Depending on the seriousness of the impact, the pre-tensioning system instantly tightens the seat belts firmly against the body of the occupant.

The pre-tensioning seat belts are armed when the ignition is on.



To be effective, a seat belt must be tensioned as close to the body as possible.

Depending on the nature and seriousness of the impact the pre-tensioning system may be triggered before and independently of the airbags.

In all cases, the airbag warning light comes on.

Following an impact, have the system checked by a PEUGEOT dealer.

The system has been designed to be fully operational for ten years. Have it replaced at the end of this period.

* According to specification

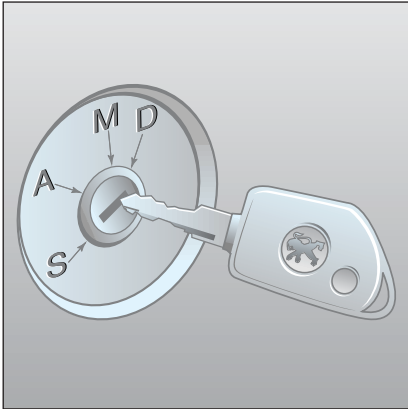

Key position

There are four positions of the ignition key in the lock:

"S" Stop: ignition is off.

"A" Accessories: ignition is off but accessories can operate. The battery charge warning lamp lights.

"M" Run: ignition on. The following warning lamps light:

- low engine oil pressure,
- coolant temperature,
- battery charge,
- pre-heater (DIESEL),
- handbrake, low brake fluid,
- engine diagnostics*,

- ABS* (lights for 3 seconds, the warning lamp should always go out when the vehicle speed is over 8 m.p.h. [12 km/h]),
- Airbag*, the warning lamp lights for six seconds, then goes out.

"D" Starter: starts the engine.

The following warning lamps go out:

- low engine oil pressure,
- battery charge,
- engine diagnostics*.

Starting

Unlock the steering

Turn the steering wheel gently while turning the key.

Before starting it is advisable to:

Press the clutch pedal while operating the starter to aid starting of the engine.

* According to specification

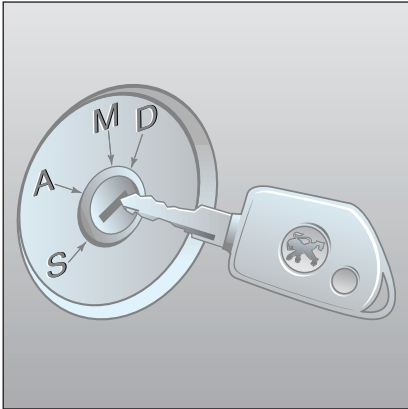

Key position

There are four positions of the ignition key in the lock:

"S" Stop: ignition is off.

"A" Accessories: ignition is off but accessories can operate. The battery charge warning lamp lights.

"M" Run: ignition on. The following warning lamps light:

- low engine oil pressure,
- coolant temperature,
- battery charge,
- pre-heater (DIESEL),
- handbrake, low brake fluid,
- engine diagnostics*,

- ABS* (lights for 3 seconds, the warning lamp should always go out when the vehicle speed is over 8 m.p.h. [12 km/h]),
- Airbag*, the warning lamp lights for six seconds, then goes out.

"D" Starter: starts the engine.

The following warning lamps go out:

- low engine oil pressure,
- battery charge,
- engine diagnostics*.

Starting

Unlock the steering

Turn the steering wheel gently while turning the key.

Before starting it is advisable to:

Press the clutch pedal while operating the starter to aid starting of the engine.

* According to specification

Starting a petrol engine*

Do not press the accelerator pedal. Operate the starter without releasing the key until the engine starts.

Starting a diesel engine

Engine cold:

Do not press the accelerator pedal. Turn the key to position “M”, the pre-heat warning lamp lights. Wait until the warning lamp goes out, then operate the starter in position “D” until the engine runs smoothly.

Engine hot:

Do not press the accelerator pedal. Operate the starter. If the engine stops or does not start immediately, always wait a few seconds before trying again using the pre-heater.

NOTE: according to specification, the pre-heat warning lamp does not light if the engine is sufficiently hot.



Never race a cold engine.

Never run the engine in an enclosed space.

If the engine cannot be stopped using the ignition key, press the brake pedal, engage a gear and release the clutch in order to stall the engine.

Do not modify the steering lock in any way.

* According to specification



Confidential card

This shows the identification code which is required if any work is carried out on the system by a PEUGEOT dealer. This code is hidden by a strip which must not be removed unless required.

Keep your card in a safe place, never in your vehicle.



When buying a second-hand car:

- *Make sure that you are given the confidential card.*
- *It is advisable to have the key codes memorised by your PEUGEOT dealer to ensure that the keys in your possession are the only ones which will permit starting of the vehicle.*
- ***Do not make any modifications to the engine immobiliser.***

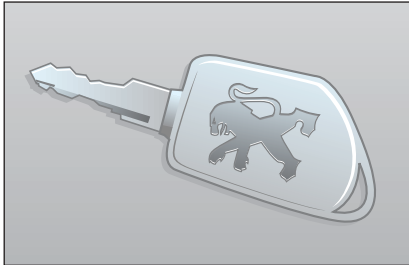

KEYS

The keys will lock or unlock the doors and the boot or tailgate independently or simultaneously by central locking, as well as the fuel tank filler cap and the steering lock. They also enable the passenger airbag* to be disarmed.

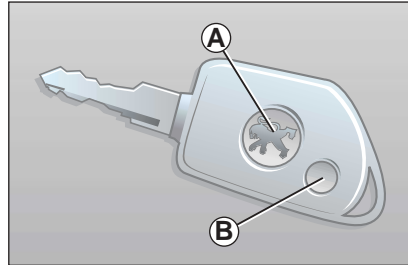

THE REMOTE CONTROL

A single press on button **A** locks the doors and boot or tailgate.

A single press on button **B** unlocks the vehicle.

Note:

Do not repeatedly press the button of your remote control out of range of your vehicle. You risk causing it not to work and the remote control would have to be reprogrammed.

Changing the remote control batteries

To gain access to the battery, unclip the key casing with a coin where you can see the ring (CR2016/3 V). If the remote control does not work after the battery has been changed, re-programme the remote control.

Synchronising the remote control*

- Use the key to unlock the driver's door of your vehicle.
- Within 30 seconds of unlocking your vehicle, press button **A** twice.
- The vehicle is locked by the second press of the button.

The remote control is now working again.

* According to specification

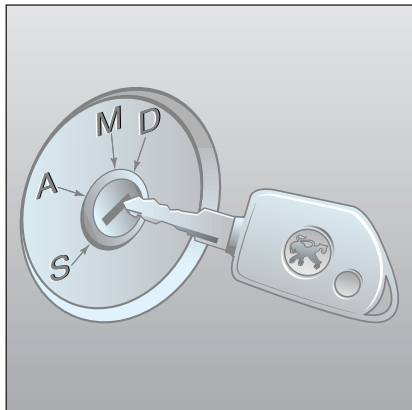

Engine immobiliser

This locks the engine control system and therefore prevents starting of the vehicle by anyone who has not got the key.

Operation

The keys which were given to you on delivery of your vehicle have an electronic chip in the plastic part of the key.

Each key therefore has a special code.

When the ignition is switched on, the key code is recognised by the engine immobiliser system and starting is possible.

If the key does not have a code or has a different code from those stored in the system memory, the vehicle will not start.

The engine immobiliser automatically locks the engine control system a few moments after the ignition has been switched off.

Additional key

You can store up to 5 keys.

If you require an additional key or wish to replace a faulty key, you must visit a PEUGEOT dealer.

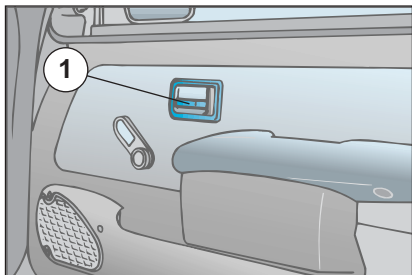

DOORS

Opening the doors from the inside

To open, pull handle 1.

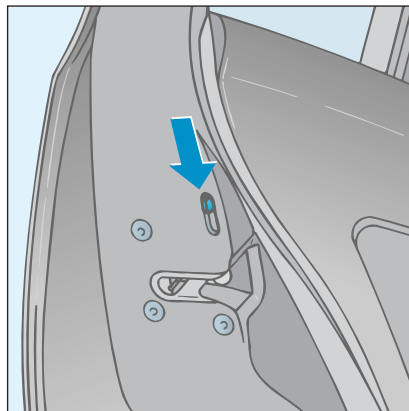

Child safety

The rear doors are fitted with child-proof locks:

Lower the catch to prevent the doors being opened from the inside.

It is still possible to open the doors from outside.

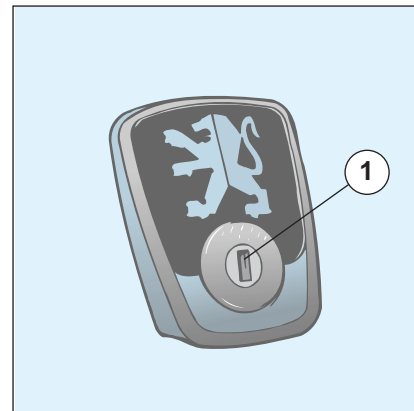

THE BOOT

Locking/unlocking the tailgate.

Using the key

To open the tailgate, turn the key then push button 1.

The light is operated by opening the tailgate*.

* According to specification

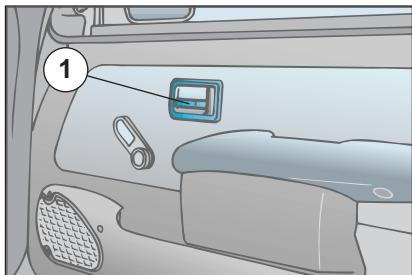

DOORS

Opening the doors from the inside

To open, pull handle 1.

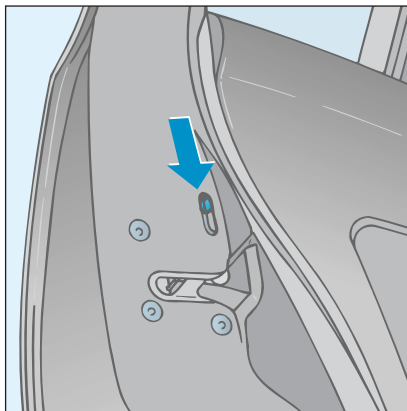

Child safety

The rear doors are fitted with child-proof locks:

Lower the catch to prevent the doors being opened from the inside.

It is still possible to open the doors from outside.

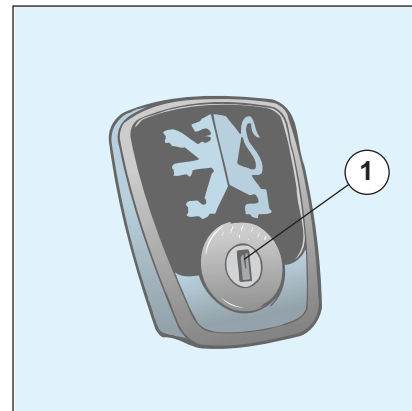

THE BOOT

Locking/unlocking the tailgate.

Using the key

To open the tailgate, turn the key then push button 1.

The light is operated by opening the tailgate*.

* According to specification

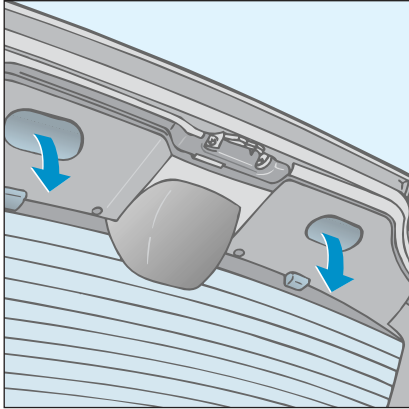

Closing the tailgate

To close the tailgate, pull either of the interior grab handles.

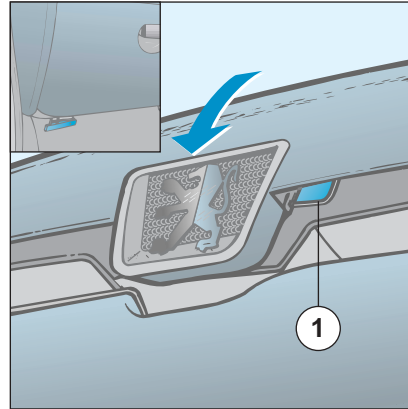

THE BONNET

Unlocking from the inside

Pull the handle.

Opening from the outside

To open:

Press the hook **1** and slowly raise the bonnet. The struts will open and keep the bonnet open.

To close:

Lower the bonnet most of the way and let it drop when it is almost closed. Check that it is locked securely.

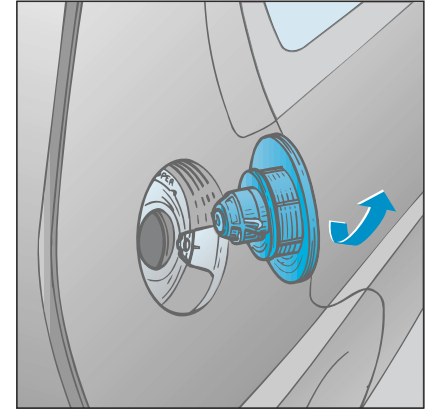

Filling with fuel

Fuel tank cap

- Insert the key, then turn it to the left.
- Remove the cap.

Tank capacity: approximately 10 gallons (45 litres).



Only fill up with fuel with the engine switched off.

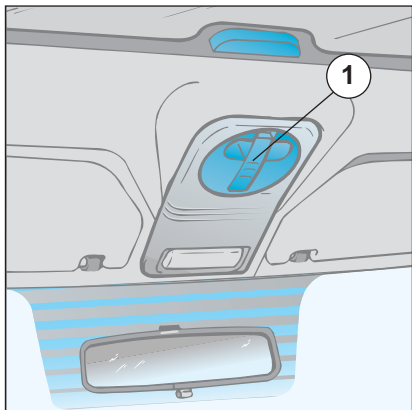

Sliding sun roof*

To open or partly open the roof:

- Open the concealing panel.
- Pull handle **1** to open out.
- Turn handle **1** the desired amount.

Tilting sun roof*

- Tilt and push the handle.

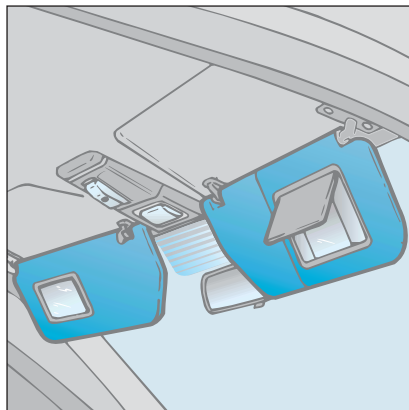

Athermic windscreen*

The windscreen has a non-reflective zone above the interior rear-view mirror.

This zone is intended for affixing toll cards or parking passes.

Note: the athermic glass of the windscreen limits the heating of the passenger compartment by reflecting more of the sun's rays.

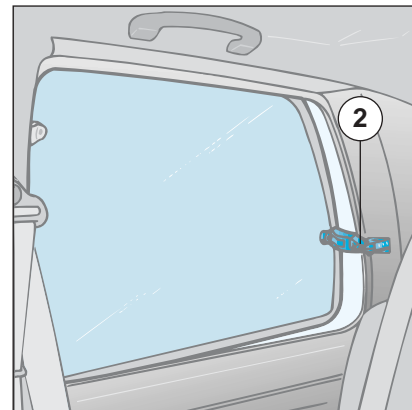

Tilting window* (3 door version)

To open the rear windows:

- Tilt lever **2** then push the window.

* According to specification

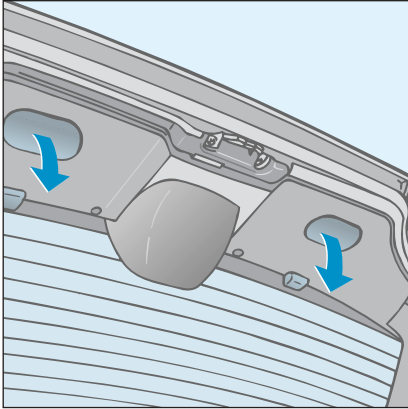

Closing the tailgate

To close the tailgate, pull either of the interior grab handles.

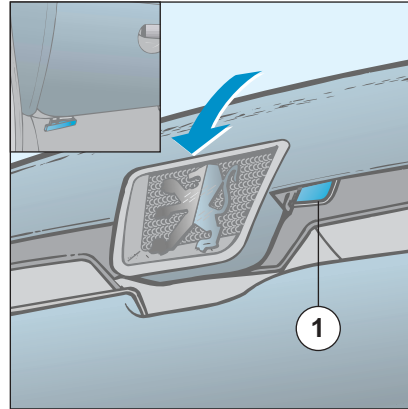

THE BONNET

Unlocking from the inside

Pull the handle.

Opening from the outside

To open:

Press the hook **1** and slowly raise the bonnet. The struts will open and keep the bonnet open.

To close:

Lower the bonnet most of the way and let it drop when it is almost closed. Check that it is locked securely.

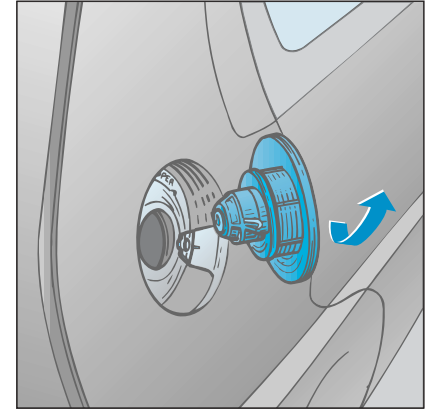

Filling with fuel

Fuel tank cap

- Insert the key, then turn it to the left.
- Remove the cap.

Tank capacity: approximately 10 gallons (45 litres).



Only fill up with fuel with the engine switched off.

LIGHTS STALK

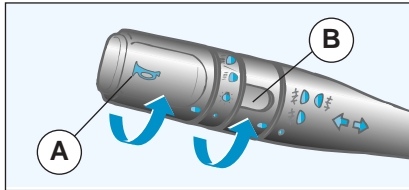
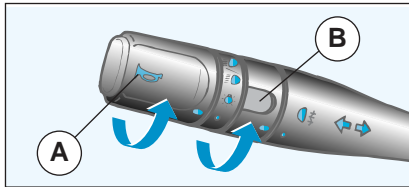

Front lights

Selection is by turning ring A.



Lights off.



Side light on.



Dipped/main beam.

Changing between dipped/main beam:

Pull the stalk fully towards you.

When your vehicle is equipped with long range light* these operate simultaneously with the main beam.

To flash the headlamps:

Flick the stalk towards you and release it.

N.B.: If the lights are left on when you switch off the engine and open a front door, a buzzer will sound.

Direction indicators (flashers)

Left, downwards.

Right, upwards.

Fog lamps

Operation is by turning ring B. The position is shown by the warning lamps on the fascia.

Rear



Light off.



Rear fog lamp lit.

It operates with the dipped/main beam headlamps.

Front and rear



Lights off.



Front fog lamps.

These operate with the side lights, dipped and main beam headlamps.



Front and rear fog lamps.

These operate with the side lights, dipped and main beam headlamps.

Switching off the side lights switches off the rear fog lamp or returns to the front fog lamps only position if the vehicle is fitted with them.

Horn

Press the end of the stalk.



In both clear and rainy weather, in daylight and at night, the rear fog lamp dazzles and is therefore prohibited.

Do not forget to switch it off as soon as it is no longer needed.

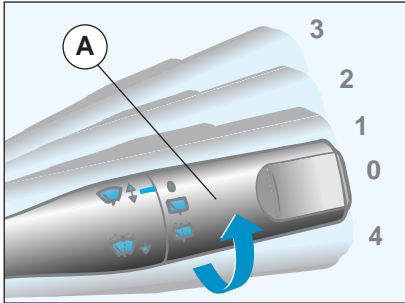

FRONT WINDSCREEN WIPER

Windscreen wiper stalk positions:

- 3 High speed wipe
- 2 Normal speed wipe
- 1 Intermittent wipe
- 0 Stop
- 4 A single wipe

To operate the windscreen wash:
Pull the wiper stalk towards you.

REAR WINDSCREEN WIPER

To operate the rear screen wiper*:

- Turn the wiper stalk **A** 1/8 turn forwards for intermittent or continuous wipe*.

To operate the rear screen wash:

- Turn the wiper stalk a further 1/8 turn forwards.

Headlamp wash*

To operate the headlamp wash*:

- Switch the headlamps to dipped or main beam.
- Pull the wiper stalk towards you.

This operates simultaneously with the windscreen wash/wipe.

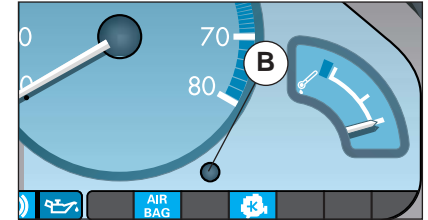

Digital clock

The time is set with the ignition on, engine off, by pressing button **B** for more than 3 seconds. The hours will then flash.

To set the hours

- A short press, the hours change slowly.
- Press and hold, the hours change swiftly. To memorise the hour displayed, release the button for 5 seconds, the minutes will then flash.

To set the minutes

- A short press, the minutes change slowly.
- Press and hold, the minutes change swiftly. To memorise the minutes displayed, release the button for 5 seconds.

* According to specification

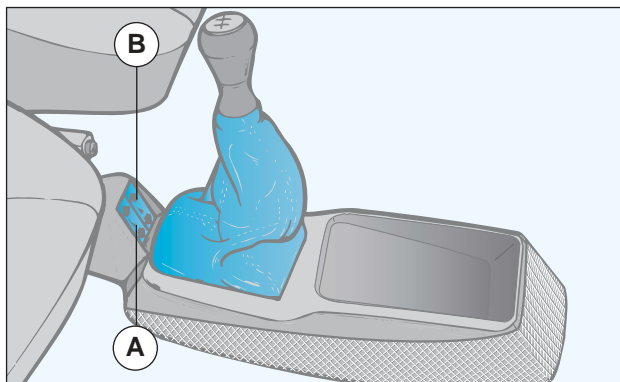
Front electric windows***To open or shut the windows:**

Ignition key in position “A” or “M”. Press the appropriate button:

- **A**: for the driver's window
- **B**: for the passenger's window

Operation is cancelled when the ignition is switched off.

* According to specification

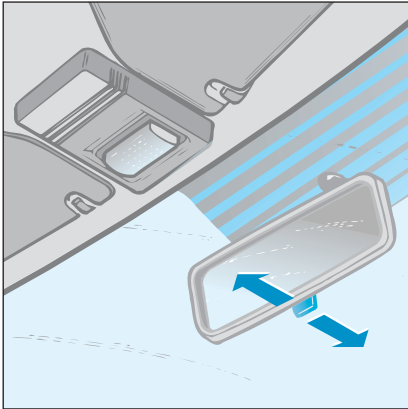

Interior mirror

The interior mirror has two positions:

- Day (normal)
- Night (anti-dazzle)

To change from one to the other: push or pull the lever on the bottom edge.

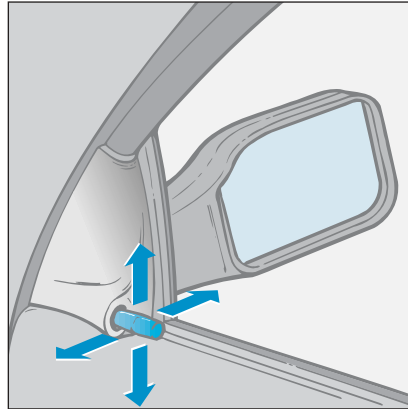

Manually controlled mirrors

To adjust:

move the adjustment lever in all four directions.

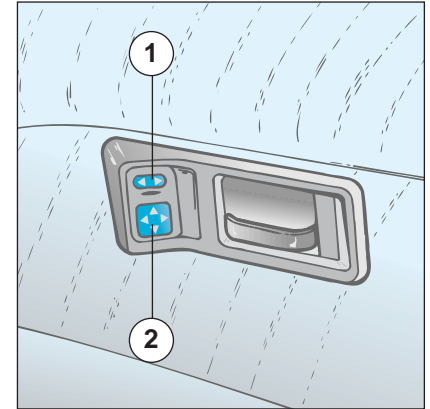

Electrically controlled mirrors*

To adjust:

- Select the mirror using the two way switch **1**.
- Adjust the mirror using control **2**.
- Return the two-way switch **1** to its central position.

When the vehicle is parked, the mirrors can be folded back manually.

Warning: The mirror on the driver's side is aspherical to eliminate the «blind spot». Therefore, objects viewed in the mirror are, in reality, closer than they appear. This must be taken into account in order to correctly judge the distance of vehicles approaching from behind.

* According to specification

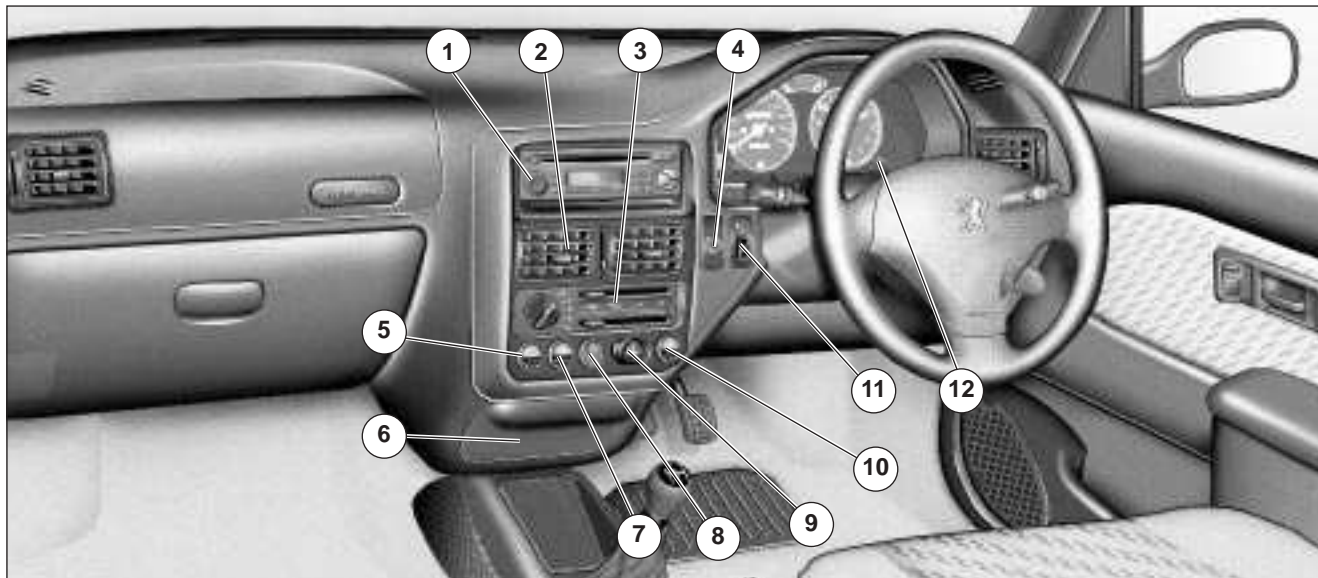

CENTRAL PANEL

- 1 - Radio cassette player.
- 2 - Central adjustable vents for heating, ventilation and air flow.
- 3 - Heating and ventilation controls.
- 4 - Passenger airbag disarming switch.
- 5 - Interior air recirculation or left-hand heated seat control*.
- 6 - Ashtray.
- 7 - Demisting control for rear screen and mirrors*.
- 8 - Hazard warning switch.
- 9 - Lighter.
- 10 - Air conditioning* or right-hand heated seat control*.
- 11 - Headlamps height adjustment.
- 12 - Lighting rheostat.

* According to specification



Hazard warning lights

The switch and the direction indicators flash.

Controls the direction indicators simultaneously and continuously.

Use only in cases of danger, for an emergency stop or for driving in unusual conditions.

Can operate with the ignition switched off.



Rear screen demister

Control for demisting the rear screen (and exterior mirrors)*.

Goes out automatically after approximately twelve minutes in order to avoid excessive current consumption.

Pushing it again restarts the operation for twelve minutes.

Lighting rheostat

Adjustment can only be done with the engine running and the side-lights on, by pressing button **12** on the instrument panel, to increase or decrease the instrument panel lighting level.



Adjusting the headlamps

Depending on the load in your vehicle, it is recommended that the headlamp beam is adjusted.

- 0** - 1 or 2 people in the front seats.
- - 3 people.
- 1** - 5 people.
- 2** - 5 people + maximum authorised load.
- 3** - Driver + maximum authorised load.

This adjustment can only be carried out when the lighting control is in the dipped/main beam position.

Initial setting is position 0.



Heated seats*

Press the switch to operate the seat heating.

Pressing it again stops the operation.

* According to specification

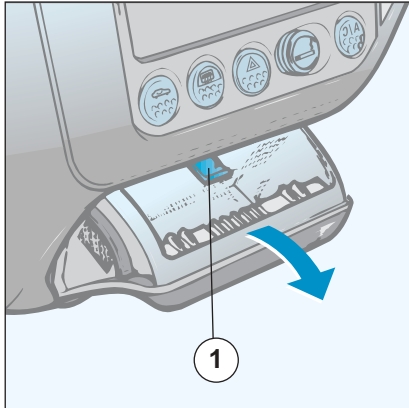

Front ashtray:

To empty:

- press tab 1, pulling on the housing
- detach the assembly upwards.

To refit:

- engage the lower part,
- press tab 1,
- push downwards and close the assembly.

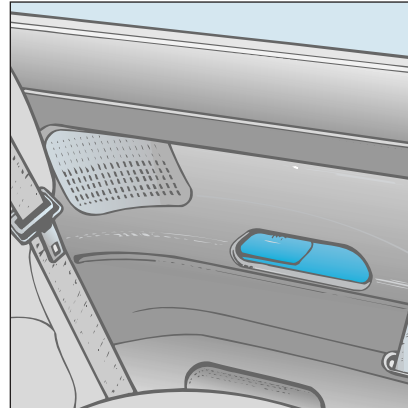

Rear ashtray*:

On 5-door:

- To empty: pull the ashtray pressing downwards.
- To refit: push the ashtray while pressing downwards.

On 3-door:

- to empty, pull the assembly upwards.

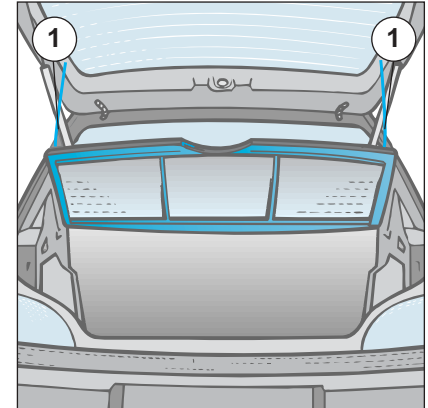

Rear parcel shelf

To remove:

- Unhook the two cords 1.
- Lift the shelf and remove it.

Fixing a warning triangle

The two restraining straps* located inside the boot enable a warning triangle to be fixed.

* According to specification.

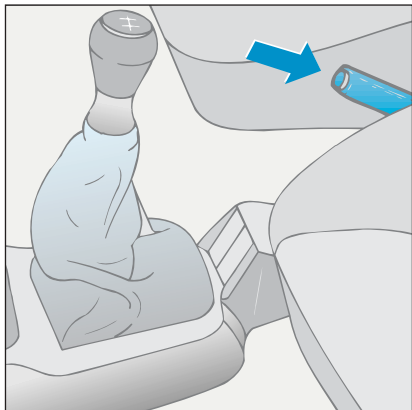

Handbrake

Application:

When you have completed your parking manoeuvre, pull up the handbrake to apply it.

To make application and release of the handbrake easier, press the brake pedal and pull the handbrake with the engine running.

Release:

Press the button before releasing the handbrake.

Anti-lock brake system (ABS)*

In conjunction with approved tyres in good condition, the anti-lock brake system improves the stability and handling of your 106, particularly on poor or slippery surfaces.

The anti-lock brake system operates automatically if there is a risk of wheel locking.

Lighting of the ABS warning lamp may be due to the turning of a wheel during an operation on the vehicle (changing a wheel, for example) with the ignition on (position **M**).

Note: In certain conditions, normal operation of the system can be recognised by a light vibration of the brake pedal.

Should an **emergency stop** be necessary, press the brake pedal firmly and continuously.

Power steering*

This is a driving aid which offers the best compromise when parking and when driving at high speeds.

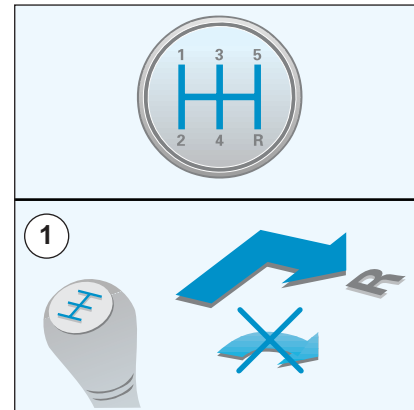

Manual gearbox

The gear positions are indicated on the gear lever knob.

1 - Reverse gear can only be engaged with the vehicle stationary and the engine idling.

* According to specification.

AIR BAGS*

The airbag system has been designed to maximise the safety of the occupants in the event of serious collisions. It works in conjunction with the seat belts.

The electronic detectors register and analyse any abrupt deceleration of the vehicle; if the triggering threshold is reached the airbags inflate instantly and come between the occupants and the vehicle.

Immediately after the impact, the airbags deflate rapidly, so that they do not hinder the visibility of the occupants and their exit if necessary from the vehicle.

The airbags are not deployed in the case of collisions which are not serious, for which the seat belt is sufficient to ensure maximum protection. The seriousness of a collision depends on the nature of the obstacle and the speed of the vehicle at the moment of the collision.

Airbags only operate when the ignition is switched on.

Note: the gas escaping from the cushion can be a minor irritant.

FRONT AIR BAGS*

These are folded in the centre of the steering wheel for the driver and in the fascia for the front passenger. They are deployed simultaneously (except in cases where the airbag is disarmed), for frontal impacts where there is a risk of injury to the head or chest.



Disarming the passenger airbag*

To ensure the safety of your child, it is essential to disarm the passenger airbag when you install a rearwards-facing child seat on the front passenger seat.

- Remove the ignition key, insert it into the passenger airbag switch **1** and turn it to the **"OFF"** position.



- One of these two warning lights* on the instrument panel is lit throughout the disarming process.

In the **"OFF"** position, the passenger airbag will not be triggered in the event of an impact.

As soon as you remove the rearwards-facing child seat from the front passenger seat, turn the airbag switch to the **"ON"** position, to arm the airbag and thus ensure the safety of your passenger in an impact.

* According to specification.

Passenger airbag precautions

Vehicle fitted with a passenger airbag disarming switch:



- disarm the airbag if you install a rearwards-facing child seat on the front passenger seat,
- arm the airbag when you transport an adult on the front passenger seat.

Vehicle not fitted with a passenger airbag disarming switch:



- do not install a rearwards-facing child seat on the front passenger seat.

Never place your feet or any object on the fascia.



Front* and side* airbag operational check

Operation of the airbags is indicated by the warning light on the instrument panel.

If the passenger airbag is armed (passenger airbag switch in the "ON" position), the warning light will come on for six seconds when the ignition is switched on.

If the warning light:

- does not come on when the ignition is switched on or,
- does not switch off after six seconds or,
- flashes for five minutes then remains on.

Consult your PEUGEOT dealer.

SIDE AIR BAGS*

The side airbags are incorporated in the backrest frames of the front seat, on the side nearest the door.

They are triggered independently of each other depending on the side on which the collision occurs, in the case of side impacts which could cause injury to the thorax, the abdomen and the head.

* According to specification

**WARNING**

For the front and side airbags to be fully effective, observe the following safety rules:

- *Wear a correctly adjusted seat belt.*
 - *Sit in a normal upright position.*
 - *Do not leave an accessory, or any other object between the occupants of the front seats and the airbags. It could hamper the operation of the airbags or injure the occupants.*
 - *All work on the airbag system is strictly forbidden unless it is carried out by qualified personnel of the PEUGEOT network.*
 - *After an accident or if the vehicle has been stolen or broken into, have the airbag systems checked.*
 - *The airbag systems have been designed to be fully operational for 10 years after the vehicle has been registered. Have them replaced by a PEUGEOT dealer after this period.*
-
- ***Front airbags****
 - *Do not drive holding the steering wheel by its spokes or resting your hands on the centre part of the wheel.*
 - *Smoke as little as possible; deployment of the airbags can cause burns or the risk of injury from a cigarette or pipe.*
 - *Never remove or pierce the steering wheel or hit it violently.*
-
- ***Side airbags****
 - *Never put covers on the front seats.*
 - *Do not fix or glue anything to the front seat backrests. This could cause injury to the chest or arms when the side airbag inflates.*
 - *Do not sit with the upper part of the body any nearer to the door than necessary.*

* According to specification

Passenger airbag precautions

Vehicle fitted with a passenger airbag disarming switch:



- disarm the airbag if you install a rearwards-facing child seat on the front passenger seat,
- arm the airbag when you transport an adult on the front passenger seat.

Vehicle not fitted with a passenger airbag disarming switch:



- do not install a rearwards-facing child seat on the front passenger seat.

Never place your feet or any object on the fascia.



Front* and side* airbag operational check

Operation of the airbags is indicated by the warning light on the instrument panel.

If the passenger airbag is armed (passenger airbag switch in the "ON" position), the warning light will come on for six seconds when the ignition is switched on.

If the warning light:

- does not come on when the ignition is switched on or,
- does not switch off after six seconds or,
- flashes for five minutes then remains on.

Consult your PEUGEOT dealer.

SIDE AIR BAGS*

The side airbags are incorporated in the backrest frames of the front seat, on the side nearest the door.

They are triggered independently of each other depending on the side on which the collision occurs, in the case of side impacts which could cause injury to the thorax, the abdomen and the head.

* According to specification

**WARNING**

For the front and side airbags to be fully effective, observe the following safety rules:

- *Wear a correctly adjusted seat belt.*
- *Sit in a normal upright position.*
- *Do not leave an accessory, or any other object between the occupants of the front seats and the airbags. It could hamper the operation of the airbags or injure the occupants.*
- *All work on the airbag system is strictly forbidden unless it is carried out by qualified personnel of the PEUGEOT network.*
- *After an accident or if the vehicle has been stolen or broken into, have the airbag systems checked.*
- *The airbag systems have been designed to be fully operational for 10 years after the vehicle has been registered. Have them replaced by a PEUGEOT dealer after this period.*

- ***Front airbags****
 - *Do not drive holding the steering wheel by its spokes or resting your hands on the centre part of the wheel.*
 - *Smoke as little as possible; deployment of the airbags can cause burns or the risk of injury from a cigarette or pipe.*
 - *Never remove or pierce the steering wheel or hit it violently.*

- ***Side airbags****
 - *Never put covers on the front seats.*
 - *Do not fix or glue anything to the front seat backrests. This could cause injury to the chest or arms when the side airbag inflates.*
 - *Do not sit with the upper part of the body any nearer to the door than necessary.*

* According to specification

1124 cm³ injection engine

- 1 . Air filter
- 2 . Brake fluid
- 3 . Battery
- 4 . Power steering
- 5 . Dipstick
- 6 . Engine oil filler
- 7 . Coolant
- 8 . Reservoir for front/rear screen and headlamp wash-wipe*

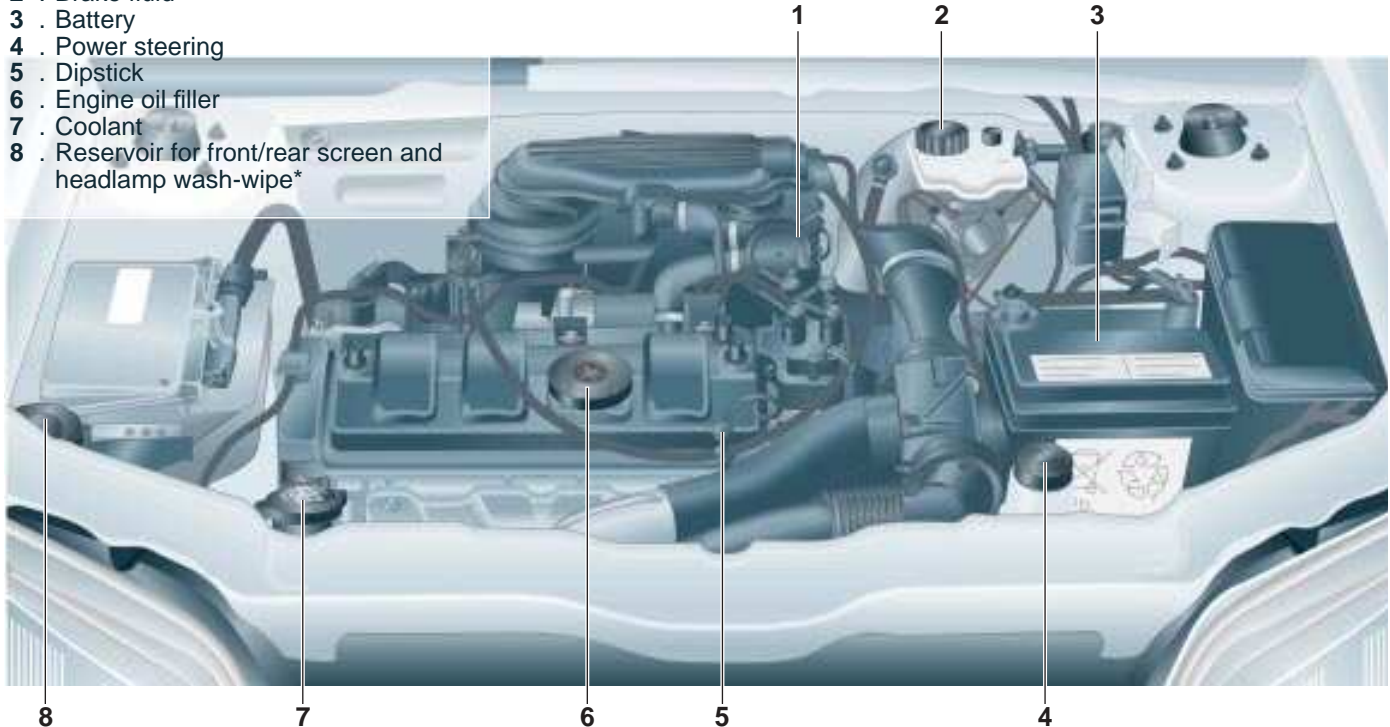

1360 cm³ injection engine

- 1 . Air filter
- 2 . Brake fluid
- 3 . Battery
- 4 . Power steering
- 5 . Dipstick
- 6 . Engine oil filler
- 7 . Coolant
- 8 . Reservoir for front/rear screen and headlamp wash-wipe*
- 9 . Automatic gearbox

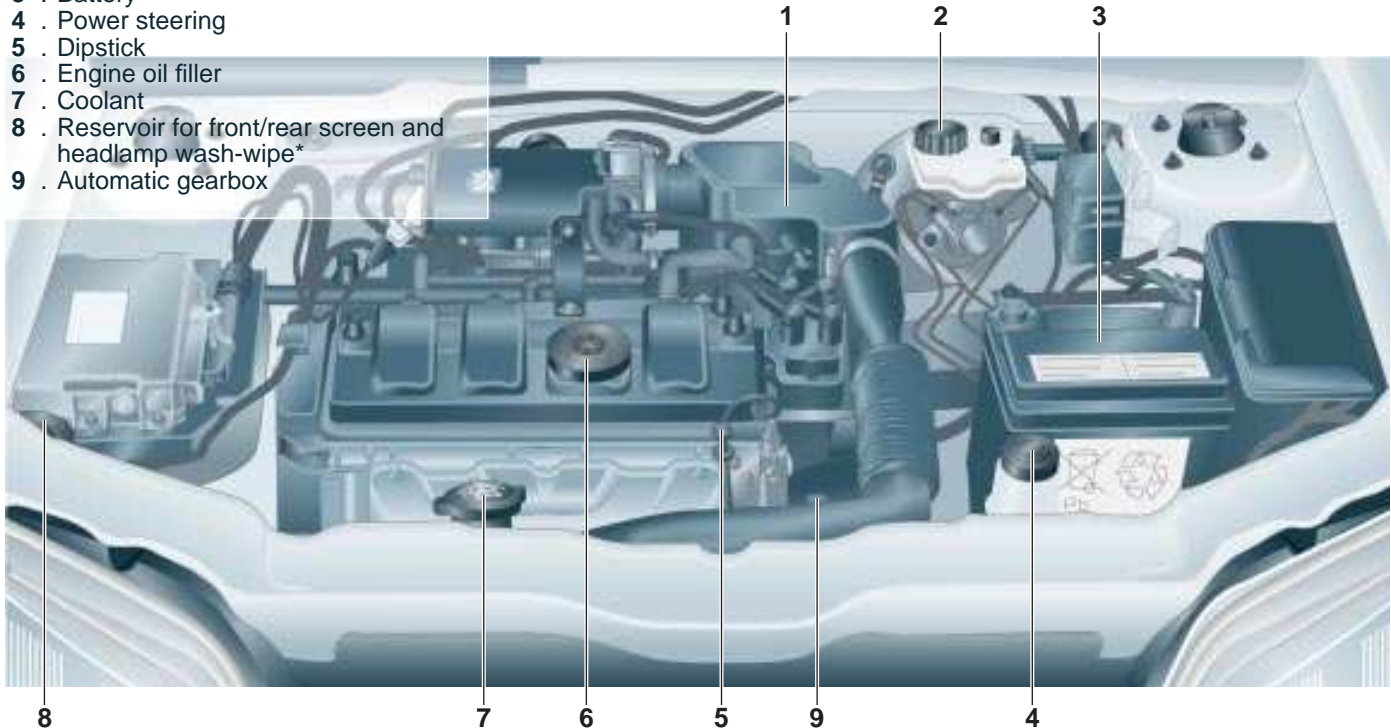

16-valves 1587 cm³ engine

- 1 . Air filter
- 2 . Brake fluid
- 3 . Battery
- 4 . Power steering
- 5 . Dipstick
- 6 . Engine oil filler
- 7 . Coolant
- 8 . Reservoir for front/rear screen and headlamp wash-wipe*

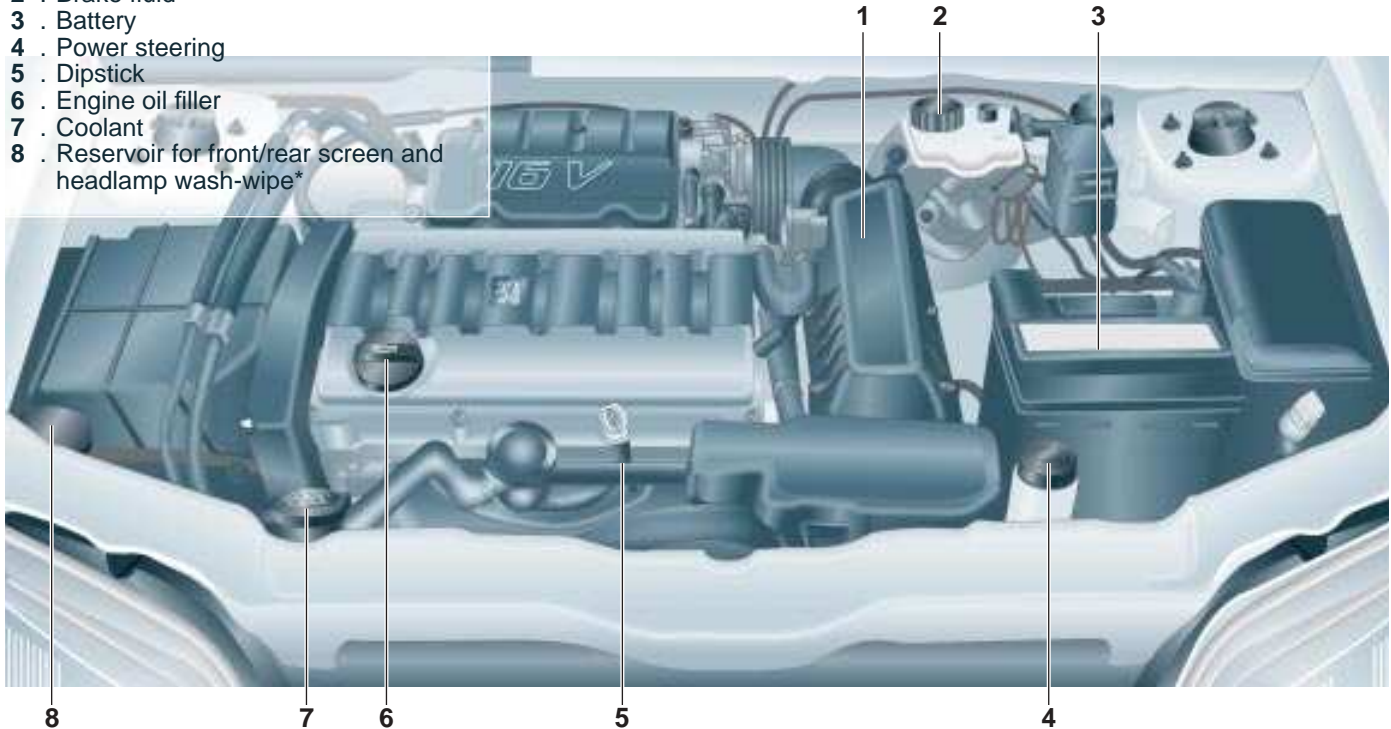

1527 cm³ diesel engine

- 1 . Air filter
- 2 . Brake fluid
- 3 . Battery
- 4 . Power steering
- 5 . Dipstick
- 6 . Engine oil filler
- 7 . Coolant
- 8 . Reservoir for front/rear screen and headlamp wash-wipe*

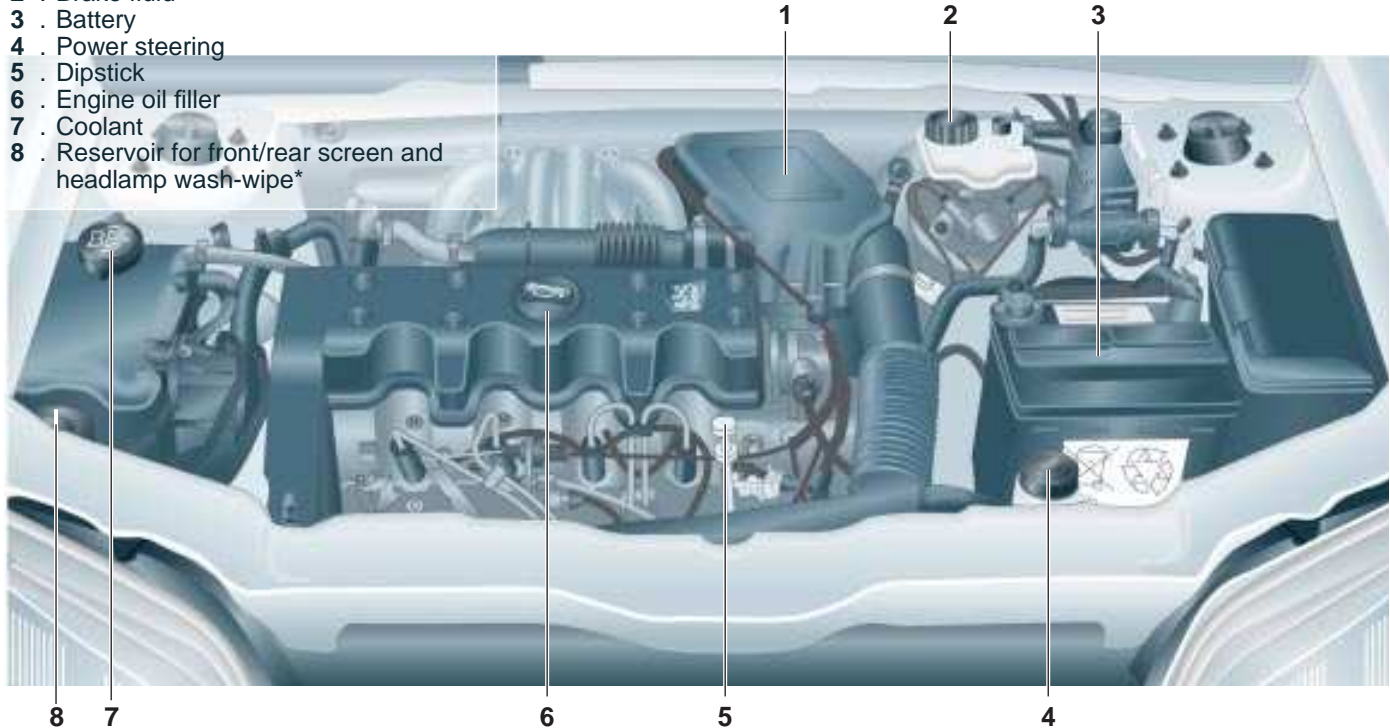

8 7

6

5

4

CHECKING THE LEVELS

1. Air filter

The air filter element must be changed at the recommended intervals. If you drive in a dusty atmosphere, change it twice as often.

Follow the recommendations given in the maintenance schedule.

2. Brake fluid

The level must always be above the DANGER mark on the reservoir. In the event of a significant drop in the fluid level, consult a PEUGEOT dealer immediately. Use fluids approved by the manufacturer, which conform to DOT 3 or DOT 4 standards.

3. Battery

At the beginning of winter, have the battery checked by a PEUGEOT dealer.

In summer (30°C and above) or if the battery is in heavy use, check the level of electrolyte; it must cover the separator plates at all times. If necessary, top up with distilled water.

4. Power steering*

When the engine is cold, the level must always be above the MIN mark, close to the MAX mark.

5. Dipstick

Check the oil level on flat ground, with the engine cold and preferably before the first journey of the day.

Never exceed the maximum level.

Check the level regularly.

6. Topping up with oil

Your oil must be changed in accordance with the maintenance schedule.

The oil must be topped up between oil changes.

Regularly check and top-up the oil level.

Maximum oil consumption is 0.5 litres per 600 miles (1000 km).

7. Coolant

Engine cold: the coolant level must be between the min and max marks in the expansion chamber with the cap removed. To close, turn the cap to the second notch*.

Cooling circuit

Always use the coolant which is approved by the manufacturer (PROCOR TM108 / GLYSANTIN G33 or REVKOGEL 2000). If this is not possible, top up with distilled water and have the protection level checked by a PEUGEOT dealer.

When the engine is hot, the coolant temperature is regulated by the fan. As the fan can operate with the ignition key removed, and as the cooling circuit is pressurised, **do not carry out any work for at least an hour after switching off the engine.**

Note: the coolant does not need to be renewed.

8. Front/rear screen and headlamp wash reservoir*

For optimum cleaning quality and for your safety, it is best to use cleaning products approved by PEUGEOT (capacity 4.5 litres without headlamp wash, 5.5 litres with headlamp wash).

* According to specification

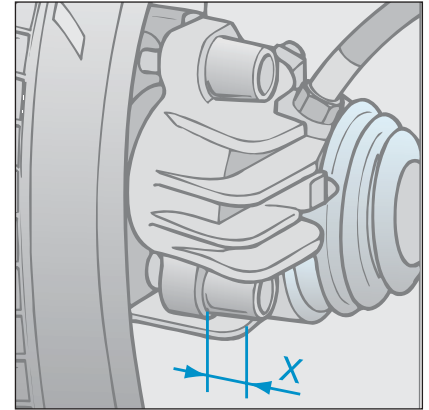
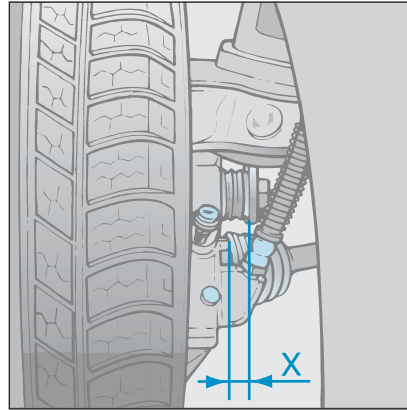
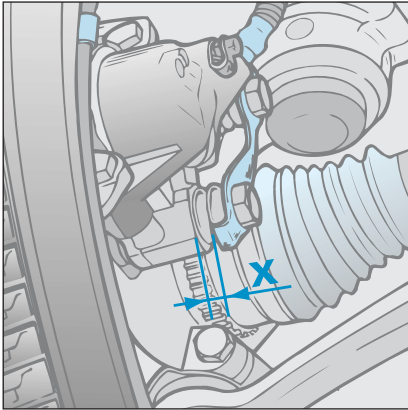

Visual brake pad wear indicator*

The front brakes are fitted with visual wear indicators. Regularly check the thickness of the brake pads.

To check: turn the wheels to full lock on the side to be checked. The thickness of pad remaining is represented by the measurement X.

When the measurement is zero, the brake pads must be changed.

Advice

As brake pad wear depends on the way in which the vehicle is driven, particularly if the vehicle is used for urban driving or for short journeys, or is driven in a very sporty manner, it may be necessary to check the thickness of the pads even between service intervals.

* According to specification

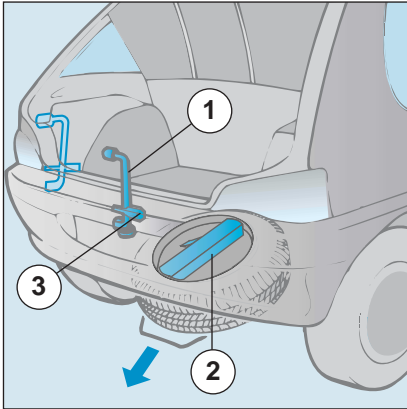

CHANGING A WHEEL

Access to the spare wheel

The spare wheel is outside, under the luggage compartment, in a metal carrier.

- Take out the wheel-brace 1.
- Using the wheel-brace 1, slacken the spare wheel carrier bolt inside the luggage compartment, under the carpet.
- Lift the carrier to disengage the hook towards the rear, then lower it.
- Take out the jack storage box 2 located in the spare wheel.

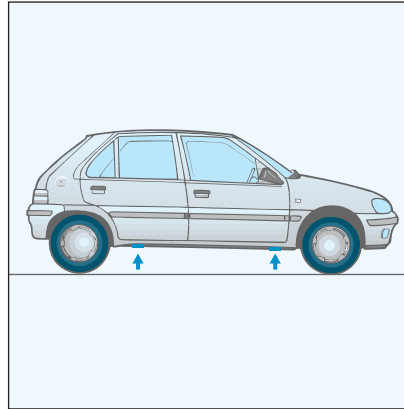

Remove the wheel

- Use the wheel-brace to remove the wheel trim by pulling at the valve location.
- Loosen the wheel bolts.
- Use the jack storage box to chock the wheel at the opposite corner to the wheel being changed.
- Position the jack head in the jacking point nearest to the wheel being changed, taking care that the entire base of the jack is in contact with the ground.
- Raise the jack, remove the wheel bolts and remove the wheel.

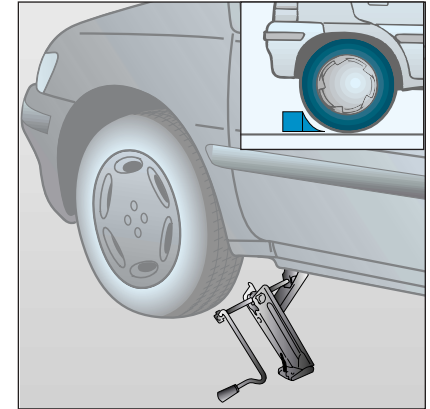

Fit the spare wheel

- Position the wheel, then lightly pre-tighten the bolts using the wheel-brace.
- Lower the jack and release it.
- Tighten the bolts using the wheel-brace.
- Fit the wheel trim, starting with the valve location, and press with the palm of the hand.

Replacing the wheel in the carrier

- Lift the wheel to aid re-positioning of the carrier.
- Do not forget to retighten the spare wheel carrier bolt.

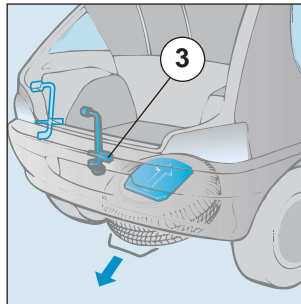
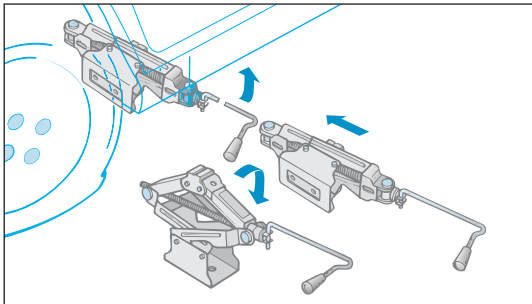

Special procedure for Sport model

Positioning the jack

- Close the jack completely.
- Position the jack under the vehicle at the jacking points tilting it by 90°, so that the jack handle hinge is at the same height as the sill trim, then straighten it.
- Check that the jack is in correct contact with the sill.

Replacing the wheel in the carrier

- Position the jack storage box with the arrow pointing forwards.

Never place the jack in contact with the sill trim.



For your safety, always change a wheel:

- on level, solid, non-slippery ground,
- with the handbrake applied,
- with first or reverse gear engaged,
- Chock the vehicle.
- Never position yourself under a vehicle which is supported only by a jack. Use a ramp.

After changing the wheel

- Have the wheel bolts and the tyre pressure checked as soon as possible.
- Have the damaged tyre repaired so that it can be returned to the vehicle as soon as possible.
- The "space-saving"* type of spare wheel is fitted with a 115/70R 15 tyre and is for temporary use only.
 - Pressure: 61 lbf. in² (4.2 bars).
 - Maximum speed: 50 m.p.h. (80 km/h).

* According to specification

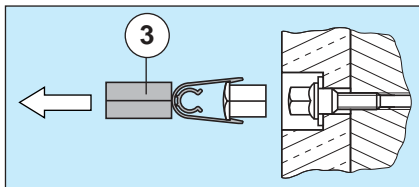

Special features of the alloy wheels*

Bolt covers

Alloy wheel bolts are covered by chrome trims.

Use tool **3** to remove the trims before slackening the bolts.

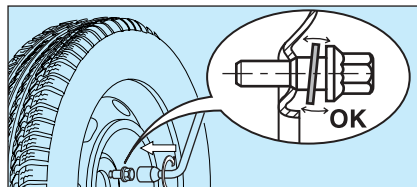

Fitting the spare wheel

If your vehicle is fitted with a steel spare wheel, it is normal when securing it to notice that the bolt washers do not come into contact with the rim. The spare wheel is secured by the cone-shaped support of each bolt.

Fitting snow tyres

If you fit snow tyres mounted on steel wheels, it is **essential** to use special bolts available from your PEUGEOT dealer.

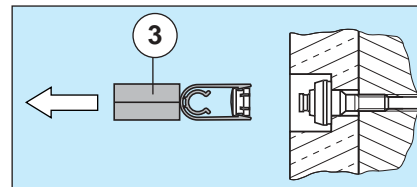

Anti-theft bolt**

If your wheels are fitted with an anti-theft bolt (one per wheel), the chrome trim and then the plastic cover must be removed, using tool **3**, before it is unscrewed using one of the two anti-theft sockets (which were given to you on delivery of your vehicle along with the duplicate keys and the confidential card) and the wheel brace **1**.

Note: make a careful note of the code number engraved on the top of the anti-theft socket. This will enable you to obtain a duplicate of the anti-theft socket from a PEUGEOT dealer.

* According to specification.

** According to model and destination.

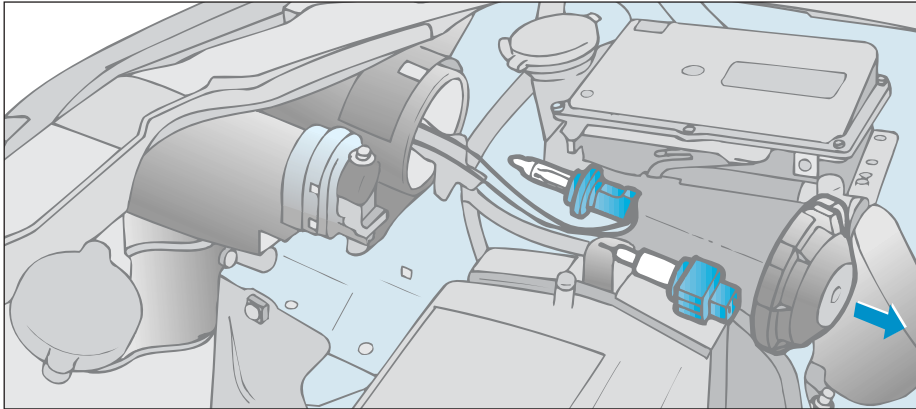

CHANGING A BULB

Side lights W5W

Turn the plastic protector 1/8 turn and remove it.
Change the bulb.

Dipped/main headlamps H4 55/60 W

Turn the plastic protector 1/8 turn and remove it.

Disconnect the connector.

Press the spring to unhook it then change the bulb.

When refitting the plastic protector, ensure that the locating notches are correctly positioned and that the protector is properly secured.

Only touch the bulb with a dry cloth.



There is a risk of damage to the dipped/main headlamps. Only use bulbs supplied by the following manufacturers:

- TUNGSRAM
- PHILIPS
- OSRAM
- NORMA

These comply with the anti-UV (Ultra-Violet) requirements necessary for correct operation and reliability of the headlamps.

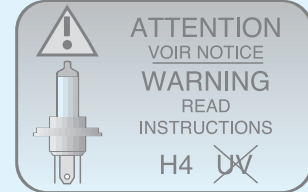

The headlamps are fitted with polycarbon glass with a protective coating. We strongly advise against cleaning them with a dry or abrasive cloth or with products containing detergents or solvents.

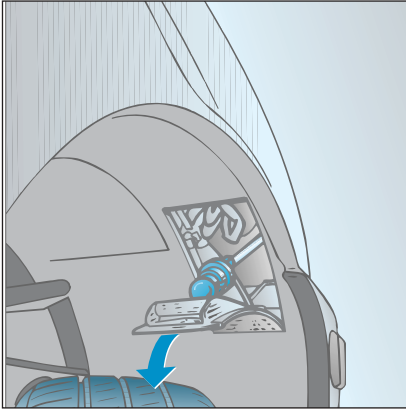

Direction indicator bulbs PY21W

Access to the bulbs is from inside the wheel arch.

Turn the wheels to full lock (to the left to change the right hand bulb and vice versa).

Open the access flap.

Turn the socket 1/4 turn.

Change the bulb.

Ensure that the flap is closed correctly.

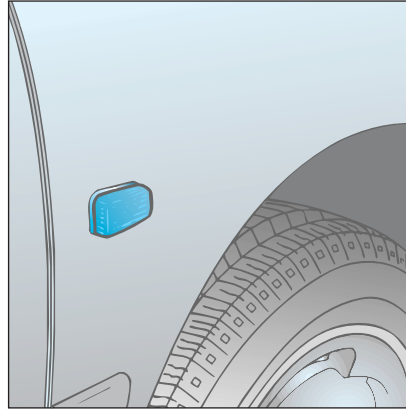

Side repeater W5W*

Pull the rear part of the transparent cover and detach the assembly.

Support the connector and turn the transparent cover 1/4 turn.

Change the bulb.

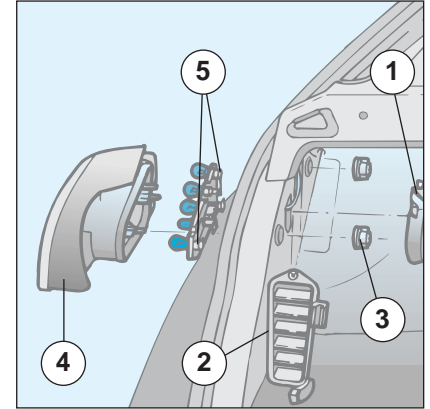

Rear lights

Direction indicators **PY21W**

Reversing lights **P21W**

Fog lamp **P21W**

Tail lights **P5W**

Brake/tail lights **P21/5W**

From inside the luggage compartment:

Remove the plastic protector **1**.

Remove the air outlet grille **2** using a cross-head screwdriver.

Slacken the two wing nuts **3** and release the light block **4**.

Pinch the lugs **5** to remove the bulb-holder. Change the bulbs.

* According to specification

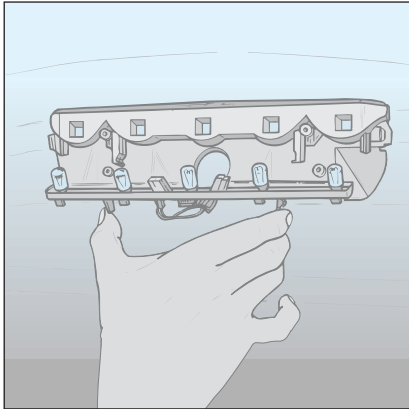

Additional brake light 5 W5W bulbs

Access to the light is easier if the luggage compartment is open.
Remove the plastic protector by pressing the side tabs.
Pinch the lugs to release the bulb-holder.
Change the bulbs.

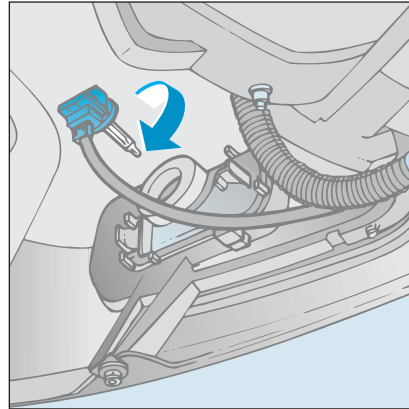

Front fog lamps/long range lights H1/55W*

Access to the bulbs is from underneath the vehicle.
Turn the socket a 1/4 turn.
Change the bulb.

* According to specification

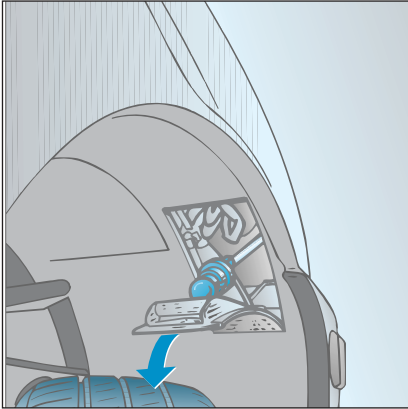

Direction indicator bulbs PY21W

Access to the bulbs is from inside the wheel arch.

Turn the wheels to full lock (to the left to change the right hand bulb and vice versa).

Open the access flap.

Turn the socket 1/4 turn.

Change the bulb.

Ensure that the flap is closed correctly.

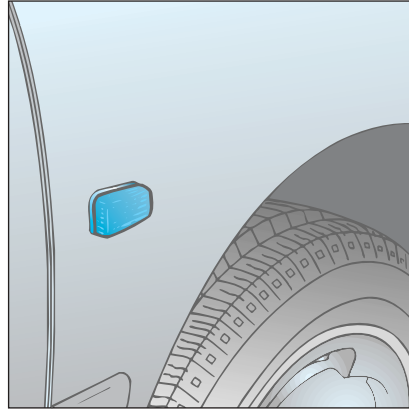

Side repeater W5W*

Pull the rear part of the transparent cover and detach the assembly.

Support the connector and turn the transparent cover 1/4 turn.

Change the bulb.

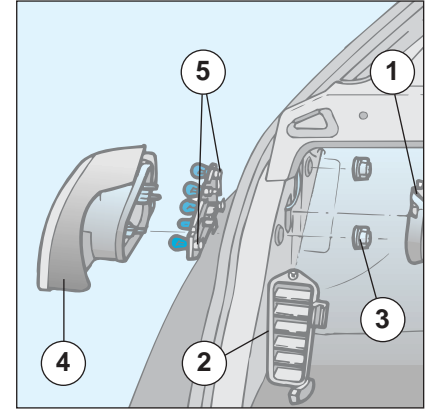

Rear lights

Direction indicators **PY21W**

Reversing lights **P21W**

Fog lamp **P21W**

Tail lights **P5W**

Brake/tail lights **P21/5W**

From inside the luggage compartment:

Remove the plastic protector **1**.

Remove the air outlet grille **2** using a cross-head screwdriver.

Slacken the two wing nuts **3** and release the light block **4**.

Pinch the lugs **5** to remove the bulb-holder. Change the bulbs.

* According to specification

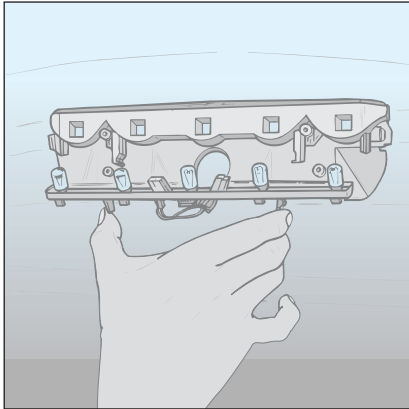

Additional brake light 5 W5W bulbs

Access to the light is easier if the luggage compartment is open.
Remove the plastic protector by pressing the side tabs.
Pinch the lugs to release the bulb-holder.
Change the bulbs.

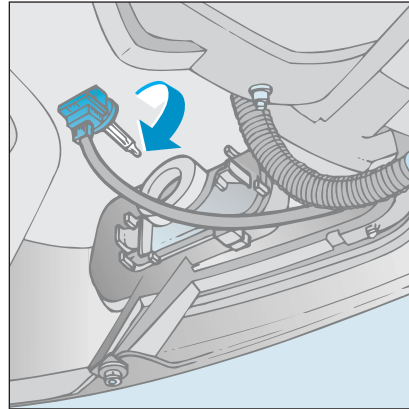

Front fog lamps/long range lights H1/55W*

Access to the bulbs is from underneath the vehicle.
Turn the socket a 1/4 turn.
Change the bulb.

* According to specification

Removing-fitting a fuse

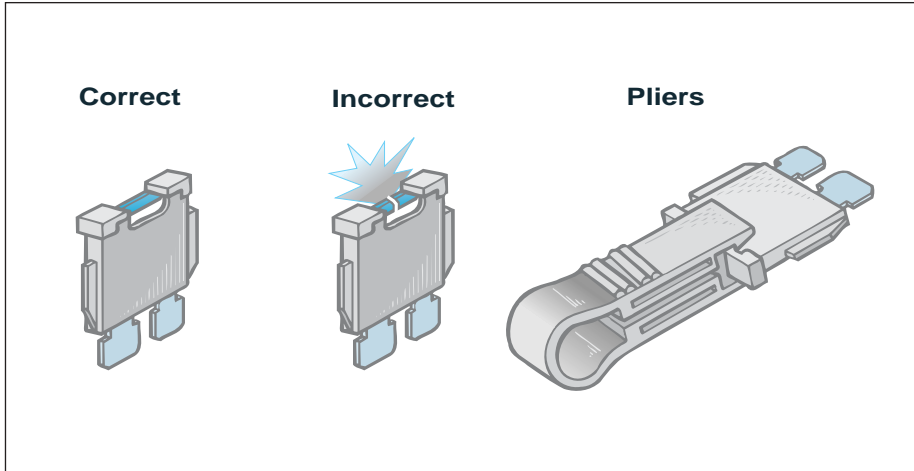

Before removing a fuse the cause of the fault must be found and corrected.
 The fuse numbers are on the fuse box.

Always change a faulty fuse for one of the same rating.



Beware of incompatible additional electrical accessories!

Your vehicle's electrical circuit is designed to operate with standard or optional equipment. Before installing additional electrical equipment or accessories, consult a PEUGEOT dealer.

Some electrical accessories, or the way in which they are fitted, may adversely affect the operation of your vehicle, namely, the electronic control circuits, the radio circuit and the electrical charging circuit.

PEUGEOT does not accept any responsibility for expenses incurred by repairs or for any faults resulting from the installation of additional accessories which are not supplied or recommended by PEUGEOT and which were not installed in accordance with the manufacturer's instructions, in particular equipment with a consumption greater than 10 milliamps. The maxi fuses provide additional protection for the electrical systems. Any work must be carried out by a specialist.

PRACTICAL INFORMATION

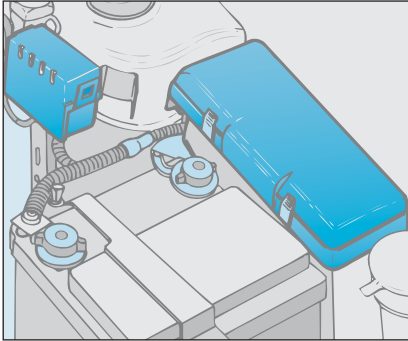

The 16 fuse boxes and maxi fuse boxes are located under the bonnet.

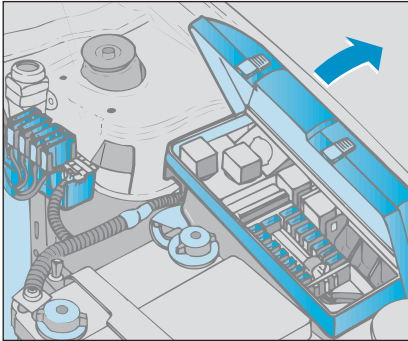

To gain access to the fuses, unhook the covers.

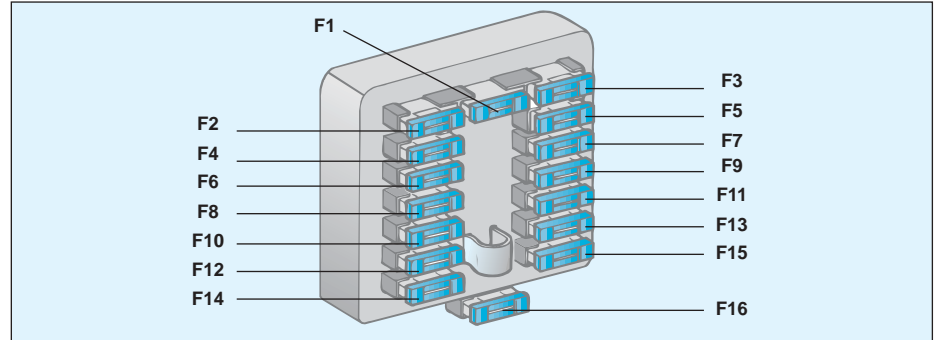

16 fuse box

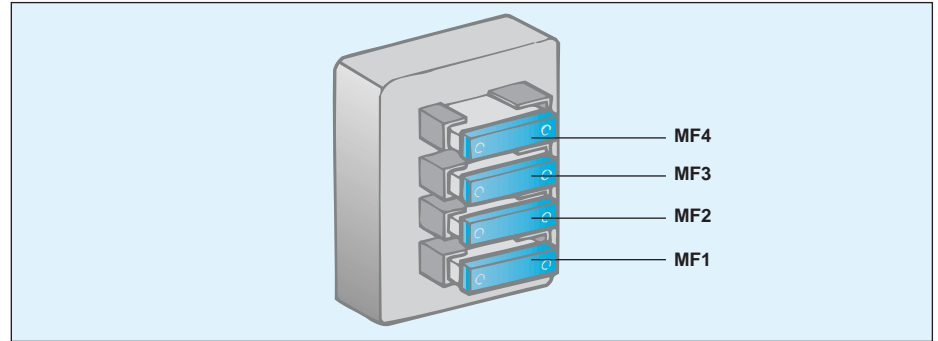

Maxi fuse box

PRACTICAL INFORMATION

16 fuse box (engine compartment)

Fuse	Rating*	Functions*
1	—	Not used
2	30A	Anti-lock braking system
3	25A	Engine cooling
4	20A	Anti-lock braking system
5	25A	Fan unit
6	20A	Additional driving lamps
7	—	Not used
8	—	Not used
9	10A	Fuel pump
10	—	Not used
11	10A	Oxygen sensor
12	10A	Left-hand main beam
13	10A	Right-hand main beam
14	10A	Left-hand dipped beam
15	10A	Right-hand dipped beam
16	30A	Pulsair pump

Maxi fuse (engine compartment)

MF1	20A	Lighting switch
MF2	80A	Ignition supply (starter +ve)
MF3	40A	Ignition supply (ignition controlled +ve)
MF4	40A	Battery +ve feed to 13-fuse box

* According to specification.

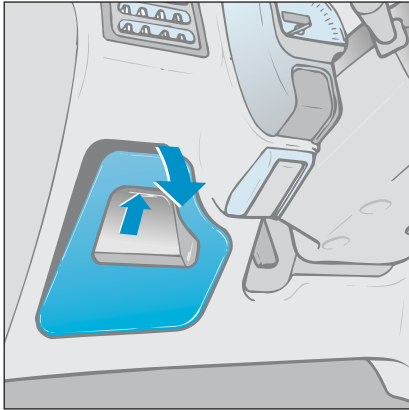

13 fuse box in the passenger compartment

To gain access to the passenger compartment fuse box, press the lug on the upper section and pull the flap towards you.

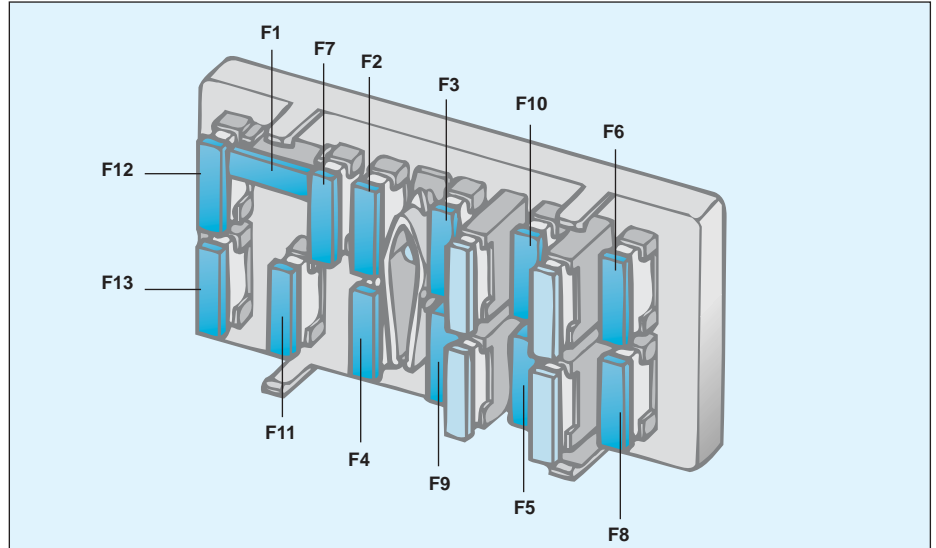

13 fuse box

PRACTICAL INFORMATION

13 fuse box (passenger compartment)

Fuse	Rating*	Functions*
1	—	Not used.
2	25A	Heater blower.
3	25A	Heated rear screen – air conditioning – pressure switch – heated seats.
4	25A	Radio – map reading light.
5	30A	Heated rear screen - horn - lighter + heated mirrors.
6	10A	Direction indicators / hazard warning lights.
7	10A	Engine cooling – electronic immobiliser – coolant temperature control unit – instrument panel – power steering – reversing lights.
8	20A	Central locking - electronic immobiliser – interior lighting – boot lighting - coolant temperature control unit - instrument panel - radio - clock.
9	30A	Electric windows - hazard warning lights - electric mirrors – brake lights – front and rear wipers - instrument panel.
10	20A	Front electric windows.
11	5A	Rear fog light + instrument panel lights.
12	5A	Left tail-light – front sidelights - instrument panel lighting (rheostat) + headlamp height adjustment.
13	5A	Switch lighting – radio panel lighting – number plate lighting – right tail light

* According to specification.

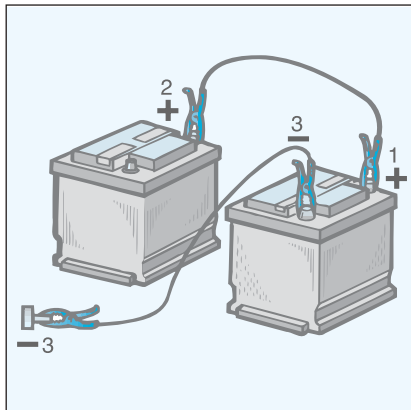

Battery

To charge the battery **with a battery charger**:

- Disconnect the battery starting with the negative (-) terminal.
- Follow the instructions for use given by the charger manufacturer.
- Re-connect starting with the positive (+) terminal.
- Check that the terminals and posts are clean. If they are covered with sulphation (a white or green deposit), undo them and clean them.

To start and charge the battery **from another battery**:

Make sure that the connections are correct:

- Connect the red cable to the positive (+) terminals of both batteries.
- Connect one end of the green or black cable to the negative (-) terminal of the auxiliary battery.
- Connect the other end of the green or black cable to an earth point on the broken down vehicle as far as possible from the battery.

Operate the starter and allow the engine to run.

Wait for the engine to return to idle, then disconnect the cables.

It is advisable to disconnect the battery if the vehicle is to be out of use for more than one month.



- *Do not disconnect the terminals while the engine is running.*

- *Do not recharge batteries without first disconnecting the terminals.*

- *A permanent electrical supply is necessary for operation of the electronic systems. If the battery is disconnected, switch on the ignition and wait 10 seconds before starting. However, if minor disturbances occur following disconnection contact a PEUGEOT dealer.*

Fitting a radio

Your 106 has the following factory-fitted equipment:

- Roof aerial.
- Coaxial aerial lead.
- Basic suppression.
- Supply to front speakers (according to specification, the wires are located in the pillars in front of the doors).
- Supply to rear speakers*.
- 2 x 8-way connectors.

It only remains for you to connect your radio and fit the speakers.

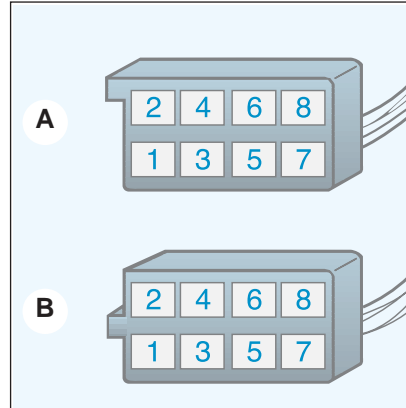

The connectors

- A1** : —
- A2** : —
- A3** : —
- A4** : (+) Accessories
- A5** : —
- A6** : (+) Parking lights
- A7** : (+) Permanent
- A8** : Earth
- B1** : (+) Right-hand rear speakers*
- B2** : (–) Right-hand rear speakers*
- B3** : (+) Right-hand front speakers
- B4** : (–) Right-hand front speakers
- B5** : (+) Left-hand front speakers
- B6** : (–) Left-hand front speakers
- B7** : (+) Left-hand rear speakers*
- B8** : (–) Left-hand rear speakers*

Fitting speakers

Provision is made for fitting 130 mm diameter speakers in the front doors. (It is possible to fit 100 mm diameter speakers at the rear*).

Consult a PEUGEOT dealer.

* According to specification

To tow your 106 without lifting...

A towing bar should always be used.

From the front and rear:

- Attach the towing bar to the towing eye.

Tow-bar

This device must be fitted by a PEUGEOT dealer.

Towing (boat, caravan, etc.)

- before setting out:
 - check the pressure of the tyres, both on the vehicle and on the trailer.
 - check the electrical signals on the trailer
 - practice manoeuvring, in particular reversing.
 - grease the tow ball regularly, remove it when you have finished towing.
- In a caravan, distribute the load inside evenly and do not exceed the maximum load.
- Always drive at a moderate speed, change gear early, both going uphill and downhill. Pay attention to side winds.
- When towing, fuel consumption increases. Do not forget to use a roof deflector if necessary.
- Braking distance increases. Brake gradually and gently. Avoid jerky braking.

Do not exceed your vehicle's towing capacity.

Towing weight: see 'Technical data' section.

Recommended nose weight: 50 kg.

For your PEUGEOT, only use accessories and original parts approved by the manufacturer.

These accessories and parts are all suitable for your PEUGEOT, after being tested and approved for reliability and safety.

A wide choice of original accessories, approved by PEUGEOT, is available through the network.

They all carry the PEUGEOT guarantee.

- Security:** Anti-theft alarms, engraving of windows, wheel anti-theft devices, fog lamps...
- Comfort:** Air conditioning, telephone console, seat covers, carpets, luggage compartment tray, mud flaps, sun roof*, luggage net, armrest, door deflectors, storage under the rear parcel shelf...
- Communication:** Audio equipment, telephone, CB, loud speakers, CD changer, navigation...
- Personalisation:** Tailgate spoiler, alloy wheels, finishers, steering wheels, sport exhaust...
- Leisure:** Towbar, roof bars, roof box, carriers (for bicycles, skis...)
- Children:** Booster seats and child seats, side blinds and rear blind...
- Maintenance products:** Windscreen wiper fluid, internal and external cleaning and maintenance products...

* As the fitting of a sun roof may involve cutting the roof strengthener, it is imperative that only original PEUGEOT products are used.

Data

Models model codes	PETROL		
	1CHFF 1AHFF 1SHFF	1CKFW 1AKFW	1CNFXF
Engines	HFX	KFW	NFX
Capacity (cm ³)	1124	1360	1587
Bore x stroke (mm)	72 x 69	75 x 77	78,5 x 82
Maximum power EU standard (Kw)	44,1	55	87
Maximum power at (rpm)	5500	5500	6600
Maximum power EU standard (Nm)	94	120	145
Maximum torque at (rpm)	3500	3400	5200
Fuel	Unleaded	Unleaded	Unleaded
Catalytic converter	YES	YES	YES
Gearbox	Manual (5 gears)	Manual (5 gears)	Manual (5 gears)
Unit capacities (in litres)			
Engine (with/without filter change)	2,9 / 3,0	2,9 / 3,0	2,9 / 3,2
Gearbox - final drive	2	2	2
Fuel tank	45	45	45

Data

	DIESEL
Models	1CVJXF
model codes	1AVJXF
	1SVJXF
Engines	VJX
Capacity (cm ³)	1527
Bore x stroke (mm)	77 x 82
Maximum power EU standard (Kw)	42
Maximum power at (rpm)	5000
Maximum power EU standard (Nm)	95
Maximum torque at (rpm)	2250
Fuel	Diesel
Catalytic converter	(1)
Gearbox	Manual (5 gears)
Unit capacities (in litres)	
Engine (with/without filter change)	4,25 / 4,50
Gearbox - final drive	2,4
Fuel tank	45

(1) According to country

Fuel consumption

			According to current directive. MPG (litres/100km)			
Engine	Gearbox	Model code 1C..., 1A..., 1S...	Urban driving	Out-of-town driving	Mixed driving	CO ₂ emission weight
1124 cm ³	MA/5	HFX	35.3 (8.0)	56.5 (5.0)	46.3 (6.1)	145
1360 cm ³	MA/5	KFWF	34.4 (8.2)	56.5 (5.0)	45.6 (6.2)	148
1360 cm ³ (sport)	MA/5	KFWU	33.6 (8.4)	54.3 (5.2)	44.1 (6.4)	152
1587 cm ³ 16 valves	MA/5	NFXF	22.4 (12.6)	45.6 (6.2)	33.2 (8.5)	201
1527 cm ³ Diesel	MA/5	VJX	41.5 (6.8)	65.7 (4.3)	54.3 (5.2)	138

Fuel consumption figures correct at the time of printing.

Loads and towing weights (in kg)

3 DOOR HATCHBACK						
Model codes: 1 C...	HFF	KFW	NFXF	VJXF		
• Kerb weight	815	815	950	875		
• Maximum vehicle weight	1295	1315	1386	1375		
• Gross train weight (GTW)	1945	2015	1886	2075		
• Unbraked trailer	400	400	400	400		
• Braked trailer (within the GTW limit)	650	700	700	700		

5 DOOR HATCHBACK						
Model codes: 1 A...	HFF	KFW	VJXF			
• Kerb weight	835	835	895			
• Maximum vehicle weight	1315	1335	1395			
• Gross train weight (GTW)	1965	2035	2095			
• Unbraked trailer	400	400	400			
• Braked trailer (within the GTW limit)	650	700	700			

VAN						
Model codes: 1 S...	HFF	VJXF				
• Kerb weight	800	860				
• Maximum vehicle weight	1295	1375				
• Gross train weight (GTW)	1945	2075				
• Unbraked trailer	400	400				
• Braked trailer (within the GTW limit)	650	700				

Dimensions and sizes (3 and 5 door)

3 door

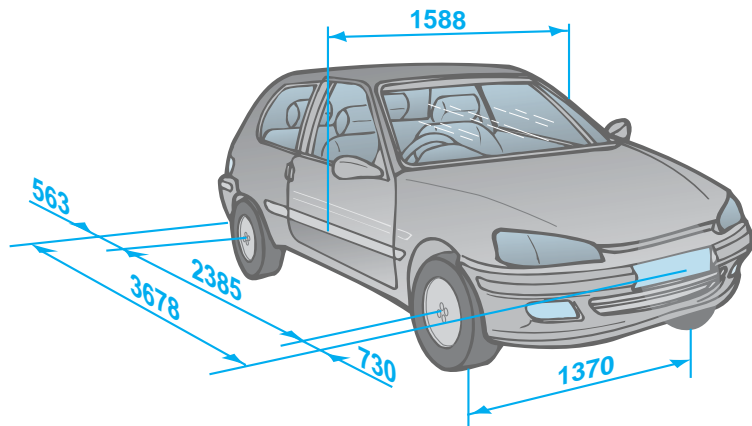

5 door

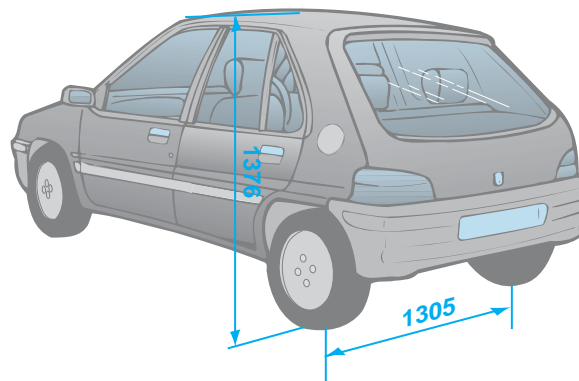

Dimensions and sizes (Sport)

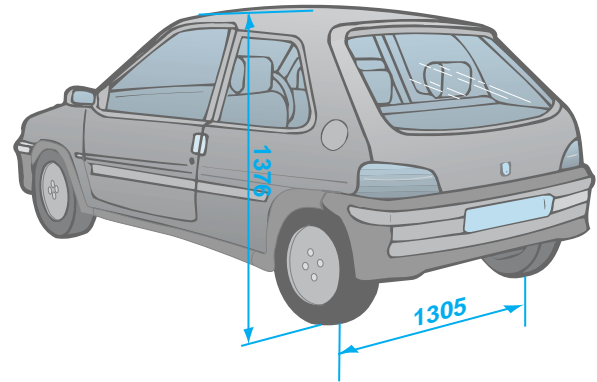
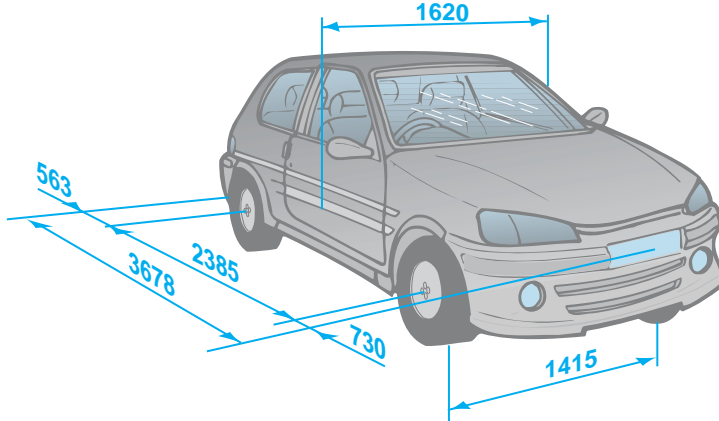

Identification

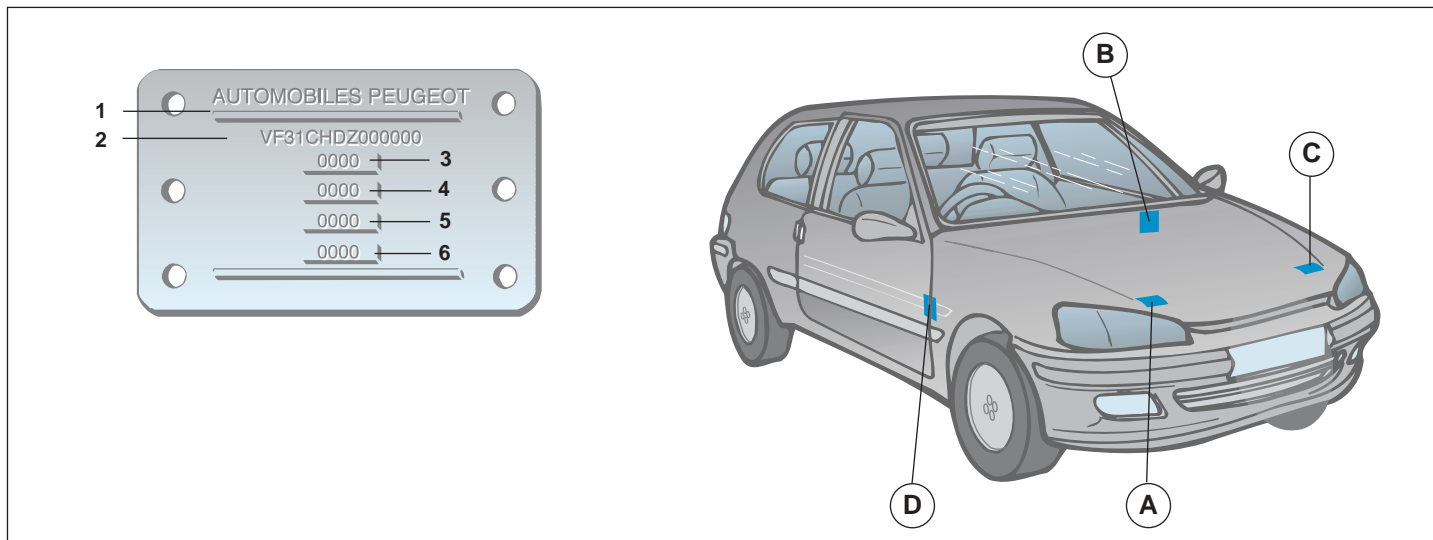
**A. Manufacturer's plate**

- 1 : EU legislation*
 2 : Serial number
 3 : Maximum gross vehicle weight (GVW)
 4 : Maximum gross train weight (GTW)
 5 : Maximum front axle load
 6 : Maximum rear axle load

B. Serial number on body**C. Legislation plate*****D. Tyres and paint reference**

The label **D** affixed to the edge of the driver's door indicates:

- the dimensions of the wheel rims and tyres,
- the brands of tyres approved by the manufacturer,
- the tyre inflation pressures (**the inflation pressure must be checked when cold, at least once a month**),
- the paint colour reference.

* According to specification