

**IF IT'S NOT WORTH DRIVING,
IT'S NOT WORTH BUILDING.®**

**WE BUILD MAZDAS.
WHAT DO YOU DRIVE?**

zoom-zoom

2013 MAZDA3



Information Provided by
DEALER
E-PROCESS



WHAT DO YOU DRIVE?

Is it inspiring?

What were the people who built your car thinking?

*Are they just another behemoth carmaker following the rules?
Or do they break them?*

*Do they push the boundaries of tradition and habit
to achieve the unachieved?*

*Are they insightful craftsmen,
obsessing over the details with a crazed passion?*

*Building less—building better—
for a discerning few?*

*Are you one of the few
who cares about what you drive,
how it drives
and the way it makes you feel?*

We're with you.

*Because we believe if it's not worth driving,
it's not worth building.®*

We build Mazdas.

What do you drive?

ZOOM-ZOOM

Is it possible to engineer zero compromise? Absolutely.

It's what happens when raising standards comes standard. It performs like a sports car, is refined like a luxury car and priced like an economy car. Fuel-efficient, fully loaded and class-shattering, it's the culmination of an entire line of Mazda innovations distilled into a single vehicle. It's a reminder of what Mazda is capable of and a symbol of what's to come. It's what happens when our best engineers, designers and craftsmen set out not to make a car—but a stand that they're not going to compromise. Because at Mazda, we believe you shouldn't either. Introducing the 2013 Mazda3.

Mazda3

One of the Top 10 Coolest New Cars Under \$18,000 for the 9th consecutive year.

Kelley Blue Book's* kbb.com

Exhilaration runs in the family.

There are so many different ways to experience the uniquely thrilling drive of the new 2013 Mazda3. Whether you choose the 4-Door sedan or 5-Door hatchback, a 2.0-liter or 2.5-liter engine, every Mazda3 is designed to let you personalize your mix of power, efficiency and amenities. For the ultimate balance of performance and fuel economy, explore the trims that feature our groundbreaking SKYACTIV®-G Engine, SKYACTIV®-Drive automatic transmission and SKYACTIV®-MT manual transmission. And for the true performance addict, there's the notorious Mazdaspeed3. No matter which one you choose, the performance and passion of the Mazda3 is always in its blood.



Mazda3 5-Door i Grand Touring with Technology Package shown in Liquid Silver Metallic



*2004 to 2012 model year vehicles. For more information about the Top 10 Coolest New Cars Under \$18,000 from Kelley Blue Book's kbb.com, visit www.kbb.com. Kelley Blue Book is a registered trademark of Kelley Blue Book Co., Inc.



Information

E-PROCESS

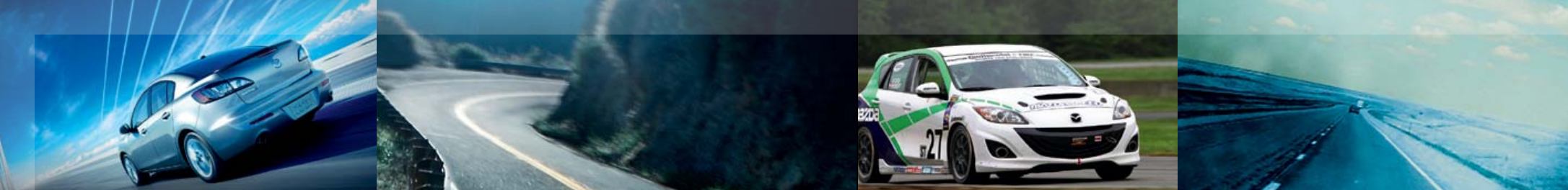

Mazda3 5-Door s Grand Touring shown in Liquid Silver Metallic



Mazdaspeed3 Touring shown in Velocity Red Mica



Mazda3 4-Door s Grand Touring shown in Liquid Silver Metallic



Fully loaded comes standard.

In the world of compact cars, the Mazda3 is a statement. A statement that you should never have to settle for basic, bland or boring. No matter which Mazda3 you choose, they all come fully equipped with a wide range of features you wouldn't expect to find in a compact car. And the best part? They're all standard.

Steering-wheel-mounted audio controls

Power windows with one-touch down/up driver's window

4-wheel disc brakes

Anti-lock Brake System with Electronic Brakeforce Distribution and Brake Assist

Dynamic Stability Control and Traction Control System

Precise rack-and-pinion steering with Electrohydraulic Power Assist Steering

Sport-tuned 4-wheel independent suspension with front and rear stabilizer bars

Air conditioning with pollen filter

4-speaker AM/FM/CD audio system with automatic level control and auxiliary-audio input jack

Advanced dual front air bags

Dual front side-impact air bags

Side-impact air curtains with front- and rear-passenger coverage

Active front headrests for added whiplash protection

Tire-Pressure Monitoring System

16-inch wheels



**"The Mazda3 is a three-time
AUTOMOBILE Magazine All-Star
for its excellent chassis and
engaging driving feel!"**

AUTOMOBILE Magazine, July 2011

Burn rubber, not fuel.

At Mazda, we strive to transform every single drop of fuel into pure adrenaline. No matter which Mazda3 you choose, you can count on one thing: Every engine, transmission and suspension system is precisely engineered to deliver a lot of fun on not a lot of gas.

Engines

Advanced all-aluminum 16-valve race-proven engines power the Mazda3 family, all of which utilize variable valve timing to help minimize fuel consumption while maximizing performance. When it comes to choices, the Mazda3 lineup offers something for everyone. Most Mazda3s are equipped with the SKYACTIV®-G engine that will not only leave you revved with 2.0-liter 155-hp excitement, but wondering how such a magnificent machine could get up to 40 highway MPG.* The affordable Mazda3 *i* SV, with a 148-hp 2.0-liter engine rated at 25 MPG city/33 MPG highway,† never asks you to sacrifice fuel efficiency for performance either. Or, go for the gusto in the 2.5L Mazda3 *s* Grand Touring that boasts 167 horsepower and still pushes past the pump with 22 city/29 highway MPG.‡

Transmissions

All Mazda3 models with the SKYACTIV®-G 2.0L engine feature the fuel-saving 6-speed SKYACTIV®-MT manual or the SKYACTIV®-Drive 6-speed automatic transmission for quick, responsive, smarter acceleration. Get exactly what you want with Mazda3's transmission choices. Both the *i* SV and *s* Grand Touring offer the same electronically controlled 5-speed Sport automatic transmission with manual-shift mode. The *i* SV also offers a 5-speed manual, while the *s* Grand Touring antes up performance with a precise 6-speed manual transmission, standard.

Standard Rear Independent Suspension

The responsive, spirited performance of Mazda3's engines is complemented by a precisely tuned 4-wheel independent suspension system. Standard on all models, this sophisticated suspension combines front MacPherson struts with an advanced multilink design at the rear, along with front and rear stabilizer bars. Also standard on all Mazda3 models is a Traction Control System that helps provide the drive wheels with a better grip during quick acceleration and Dynamic Stability Control** that helps make every turn more precise, more responsive, more enjoyable and unquestionably Mazda.

Electrohydraulic Power Assist Steering

The Mazda3's revolutionary Electrohydraulic Power Assist Steering utilizes hydraulic pressure from a pump driven by an electric motor that works independently of the car's engine. The result? Improved pin-point steering power, enhanced agility and increased fuel economy.

Information Provided by:

**i* 4-Door models with SKYACTIV®-G 2.0L engine & SKYACTIV®-Drive 6-speed automatic transmission, EPA-estimated 28 city/40 highway MPG. †EPA-estimated fuel economy with manual transmission. ‡EPA-estimated fuel economy with automatic transmission. Actual results may vary. **Dynamic Stability Control (DSC) is an electronic system designed to help the driver maintain control under adverse conditions. It is not a substitute for safe driving practices. Factors including speed, road conditions and driver steering input can all affect whether DSC will be effective in preventing loss of control. Please see your owner's manual for further details.



40
MPG

It's not the first 40 MPG sedan. It's just the first one worth driving.

Information provided by
IDEAL
E-PROCES



When we engineered zero compromise, we aimed for absolute.

Our goal? Ultimate efficiency.

To achieve the unheard of, where fuel economy, low emissions and outstanding driving performance coexist in cars accessible to everyone.

And to pull that off meant obsessively analyzing over everything we ever did, and then starting with a clean slate.

It meant engineering from the ground up and reengineering everything to work together in unprecedented harmony.

But most importantly, it meant reimagining what's possible.

We imagined an engine that pushes engineering boundaries by delivering the compression ratio of a Formula 1 race car at 12:1, creating 15% more low-rpm torque—yet 15% better fuel economy—all on 87 octane fuel.

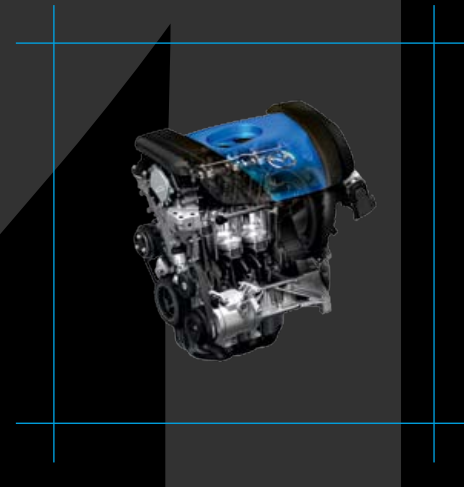

"It is a whole new, more efficient way of engineering cars. Really... ."

autoweek.com, August 2011

We imagined a smooth-shifting automatic transmission so smart it perfectly rev-matches downshifts faster than a dual-clutch transmission, while helping to improve fuel economy.

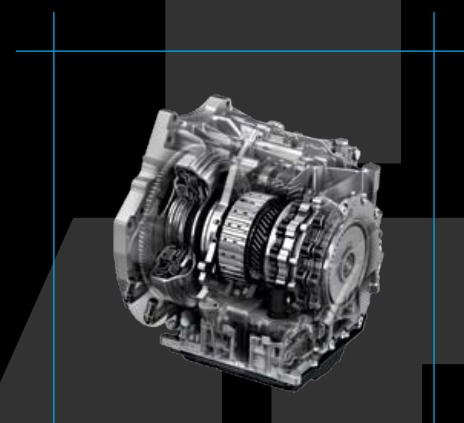

We imagined a manual transmission that helps maximize fuel efficiency more than any of its predecessors, built with less material but built just as rigid. A transmission that's smaller, lighter, stronger and has the shortest shift throw in its class.

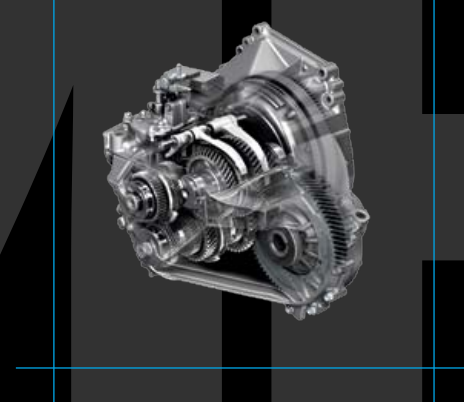

We imagined it all and more, and then we made it a reality.

Fuel economy. Performance. Together.

Introducing SKYACTIV® TECHNOLOGY from Mazda.

The future of driving begins now. www.MazdaUSA.com/skyactiv

We started with something very good, then made it very, very naughty.

Every great car potentially has a darker side. And when you're this good, you're just asking for trouble. The Mazdaspeed3 is a perfect example. A turbocharged, intercooled, direct-injected jolt of automotive adrenaline, it's definitely a beast under the hood. We're talking a powerful combination of 263 hp and 280 lb-ft of torque, all courtesy of an arsenal of go-fast enhancements that includes a high-output all-aluminum MZR 2.3-liter engine, specific-forged crankshaft and connecting rods, plus optimally tuned intake and exhaust. Connecting that power to the pavement is a 6-speed manual gearbox optimized to exploit the engine's wide torque band and Dynamic Stability Control* with a Traction Control System.

Also in play: larger-diameter ventilated front disc brakes with ABS, Electronic Brakeforce Distribution and Brake Assist; larger-diameter front and rear stabilizer bars; and a Mazdaspeed suspension system. Precisely engineered to efficiently transform every drop of gas into rocket fuel, the Mazdaspeed3 is a fully warranted straight-up tuner that's straight off the Mazda factory line.



> **Transmission:** A precise 6-speed, close-ratio, short-throw manual gearbox is standard and ready to transfer Mazdaspeed3's copious power to the pavement. It's teamed with a standard torque-sensing conical limited-slip differential and the Mazda Advanced Torque Management System.

>> **Engine:** An all-aluminum turbocharged and intercooled MZR 2.3-liter engine rockets the Mazdaspeed3 down the road. Its Direct-Injection Spark Ignition optimizes combustion, torque and fuel efficiency, plus tuned intake and exhaust systems always provide peak performance.

>>> **Foot Pedals:** Competition-inspired drilled aluminum pedals—just the kind of performance-oriented form and function you'd expect from Mazdaspeed3.



*Dynamic Stability Control (DSC) is an electronic system designed to help the driver maintain control under adverse conditions. It is not a substitute for safe driving practices. Factors including speed, road conditions and driver steering input can all affect whether DSC will be effective in preventing loss of control. Please see your owner's manual for further details.

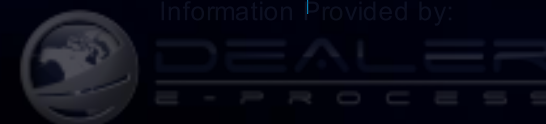



**"Getting into the Mazda, even for the first time, feels like you're at home.
Everything is exactly as it should be."**

automobilemag.com, August 2012



Information Provided by
DEALER
E-PROCESS

Mazda3 S Grand Touring interior shown in black leather



Driver-focused. To keep you road-focused.

From the moment you sit in the Mazda3, it's crystal clear that every piece of technology was specifically designed to keep you focused on the drive, not the technology itself. Which is why within the center stack, an available 5.8" full-color touch-screen magnificently displays the navigation system and is positioned for easier viewing. Convenient steering-wheel-mounted controls put audio, cruise control and Bluetooth® hands-free capabilities within thumbs' reach, and an available 8-way power-adjustable driver's seat positions you for optimum control and comfort. Get a clear view of the road with the help of available rain-sensing wipers and heated dual power remote side mirrors. At Mazda, we believe technology should focus on you, so you can focus on driving.

Multi Information Display

Located on the upper dashboard near the driver's natural line of sight is an innovative, easy-to-read Multi Information Display. Average MPG and estimated miles to empty data, ambient temperature and maintenance reminders are all at your fingertips.

Navigation System

Get to where you're going with ease with the available 5.8" full-color touch-screen display and navigation system by TomTom. It provides you with turn-by-turn directions with real-time traffic updates and features zoom, route highlighting, active road name display, advanced lane guidance and voice recognition.

High-tech hospitality.

The Mazda3 is a state-of-the-art technological powerhouse of conveniences. Even before you enter the Mazda3, you're made to feel like a guest with the Advanced Keyless Entry that instantly recognizes you as you approach the car. Once inside, its Welcome Lighting System automatically illuminates the interior lights in an elegant sequence. Eliminate the need for an ignition key with available Push Button Start, and then settle in and customize your environment with the dual-zone automatic climate control. The Mazda3 is well equipped with a wide array of available technological features that keep you informed, entertained, connected and comfortable.

Advanced Audio Features

Mazda3 comes with available HD Radio, so you get cleaner, crisper sound from a digital signal that offers multiple options for some of your favorite stations. On select Mazda3s, take advantage of a free 4-month subscription to SiriusXM Satellite Radio* with a vast array of channel choices—everything from rock and country to jazz and your favorite talk shows—almost all commercial-free.



Bluetooth® Hands-Free Phone and Audio Streaming

Keeping your eyes on the road and hands on the wheel has never been easier. With voice commands, making and receiving calls is as easy as pushing a button and saying hello, and the Bluetooth wireless capability helps you stay entertained with streaming audio from your compatible mobile device.



Mobile Device Integration

Get even more enjoyment from your mobile device through your Mazda3's audio system while charging it at the same time. With the USB audio input, you can quickly connect your music to your Mazda, allowing you to navigate your entire music library—all conveniently from the steering-wheel controls or the audio system's display.



Pandora® Internet Radio

Experience music on your terms with up to 100 unique "stations" through the available Pandora Internet radio, all seamlessly streaming through your wireless Bluetooth-enabled and Internet-connected device. Even better, it's all controlled from the on-screen display and all within sight level.

SMS Text Message Readout

Now, when a text comes in while you're driving, you can stay focused on the road ahead. Select Mazda3 models offer a fully integrated text display and audible readout, and the ability to reply by choosing from a number of preset, standardized return messages. Stay in touch—and safer—without touching your phone.



Information provided by:

10 speakers.
265 watts.
5 front-row seats.

No matter where you sit in the Mazda3, the Bose® Centerpoint® Surround Sound System makes you feel like you're enjoying an intimate concert for one—or five. Standard on all Grand Touring models and Mazdaspeed3, and available on Mazda3 *i* Touring, is an exclusive sound system you can't get anywhere else. Specifically tuned for the Mazda3's unique cabin acoustics, it features 10 high-performance neodymium magnet speakers powered by a 265-watt amplifier. Exclusive processing technology turns ordinary CDs or MP3 discs into 360 degrees of pure audio exhilaration. And for all you audiophiles out there with a true ear for details, the Mazda3 offers a wide array of state-of-the-art audio features you have to hear to believe.

- › 3.25-inch Twiddler® neodymium mid/high-range speaker
- › Two 1-inch neodymium tweeters (in L/R A-pillars)
- › Two 6.5-inch neodymium wide-range speakers (in L/R front doors)
- › Two 5.25-inch neodymium wide-range speakers (in L/R rear doors)
- › Two 3.25-inch Twiddler® neodymium mid/high-range speakers (in L/R rear deck)
- › One 9-inch, high-performance Nd® woofer (center-mounted in rear deck)
- › Bose® digital amplifier with Centerpoint® signal-processing circuitry (under passenger's front seat)
- › SurroundStage® digital processing circuitry
- › AudioPilot® noise compensation technology with eight channels of custom equalization and digital signal processing





When you obsess over details, every stitch counts.

From the look and feel of it, you'd think it was a luxury car. Every aspect of the Mazda3's interior is crafted to be as rewarding as possible; that includes details commonly found in high-priced luxury cars. On Grand Touring models, we meticulously stitched real leather to the Mazda3's high-bolstered seats, steering wheel and shifter. But we didn't stop there. Every dashboard is exquisitely crafted for a tactile feel that flows seamlessly with the graceful lines and curves throughout the rest of the interior. It's an environment that is both comfortable and refined, down to the smallest of details.



"It's hard to beat the balance of joy and practicality of the Mazda3."

Winding Road, August 2010

5 doors. 17 cubic feet. Endless possibilities.

The more you need from the Mazda3, the more it seems to give. With more overall interior room than VW Golf, the Mazda3 5-Door is a compact with up to 17 cubic feet of vast cargo space. Its convenient 5th door and 60/40 split fold-down rear seatback allows it to easily transport longer, larger items. Simply fold down the entire 60/40 rear seat back, and you've got additional cargo space for sports equipment, camping gear, luggage and more—much more.



Information Provided by
EXETER
E-PROCESS

Mazda3 5-Door s Grand Touring shown in Liquid Silver Metallic

It's a speed demon—and a guardian angel.

There's a reason the Mazda3 earned the highest rating for frontal crash test performance from the Insurance Institute for Highway Safety. In fact, there are a lot of reasons. From improved overall handling, to greater impact support, to a wide array of innovative safety technologies, the Mazda3 is precisely engineered to protect you—and your peace of mind—from every angle.

Structural Safety

Stronger, safer yet lighter, every Mazda3 utilizes Mazda's "Triple H" construction system that reinforces the floor, sides and roof, resulting in a safer, more secure structure around the driver and passenger compartments. Its high tensile steel reinforcements increase the strength of critical body areas and enhance basic structural integrity, as well as improve overall handling and provide increased impact protection.

Air Bags*

Advanced dual front air bags* that utilize inflators with both crash-zone and driver's-seat/passenger-weight sensors are standard on all Mazda3 models—as are dual front side-impact air curtains* with coverage for front and rear passengers. In the event of a collision and airbag deployment, the available E911 system will use a paired Bluetooth phone to dial emergency responders and identify your location. Added peace of mind when your loved ones are on the road.



Bi-Xenon Adaptive Front-Lighting System

The best way to protect you and your passengers starts with seeing what's ahead of you. The Mazda3 comes fully equipped with an available Adaptive Front-lighting System and self-leveling Bi-Xenon High-Intensity Discharge headlights. These headlights are specifically designed to help you see around corners at night, literally. As you turn into a corner, the adaptive inside headlight moves up to 15° in the direction of your turn, thereby improving visibility and allowing you to spot potential hazards and dangers up ahead.

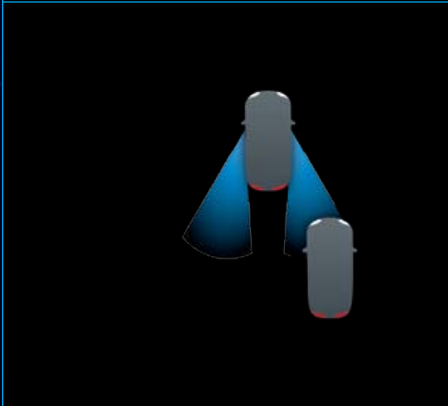
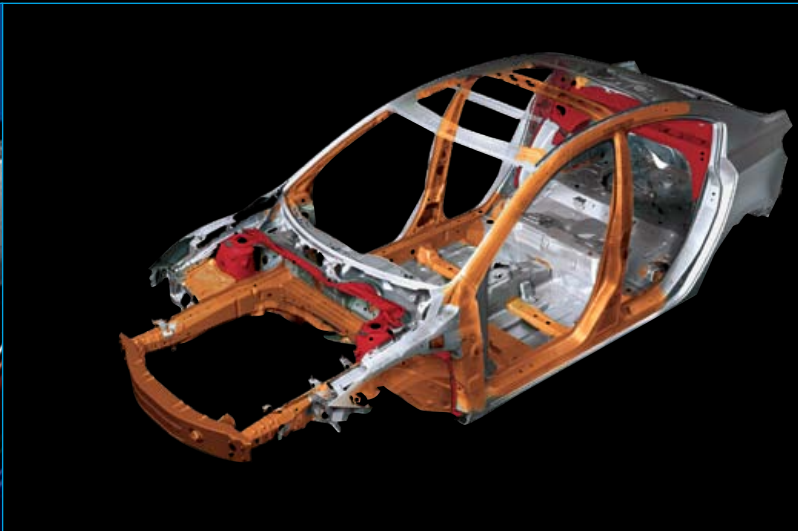

Blind Spot Monitoring System†

An available class-exclusive state-of-the-art Blind Spot Monitoring System utilizes motion sensor technology and automatically warns you of an approaching vehicle or object in your blind spot by activating an icon in the corresponding side mirror. The icon blinks and a warning beeps when the driver initiates the turn signal.

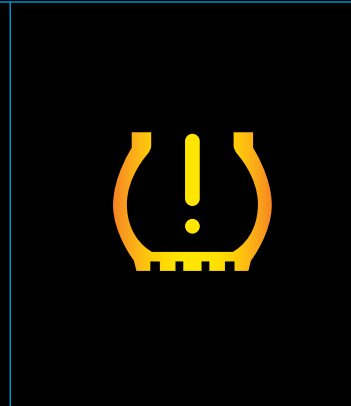

Tire-Pressure Monitoring System

Designed to monitor air pressure in real time, this system automatically alerts you before one or more tires becomes critically low.

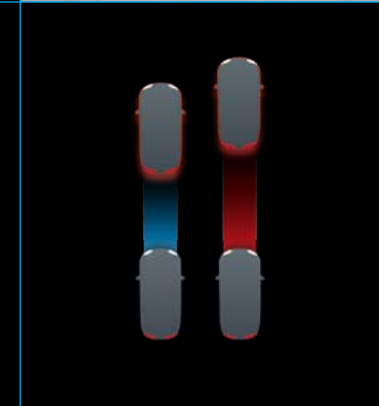

Brakes

Stopping is as much a performance aspect as anything, so we equipped the Mazda3 with standard power-assisted 4-wheel disc brakes and a wide range of other standard braking features. The Anti-lock Brake System pulses the brakes several hundred times a second, preventing wheel lock so the driver can make controlled stops. Electronic Brakeforce Distribution monitors pedal pressure and vehicle weight to determine how much force to apply to the front and rear brakes, while Brake Assist automatically increases braking pressure, thereby reducing stopping distance in emergency situations.

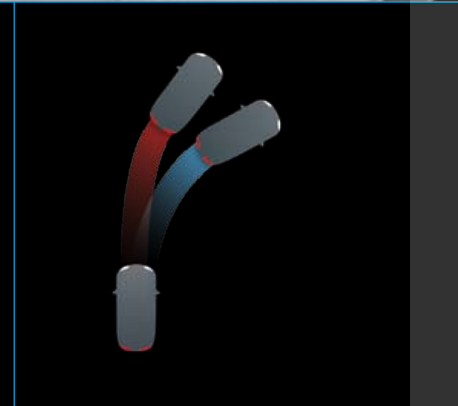

Active Safety

Standard Dynamic Stability Control‡ modulates the throttle and brakes when a sudden loss of traction is detected to help keep the vehicle stable during a turn. Standard Traction Control System detects any loss of traction, then adjusts the throttle to provide the drive wheels with a better grip on the road and more sure-footed acceleration during difficult driving conditions.

The Insurance Institute for Highway Safety has awarded the Mazda3 its coveted 2012 Top Safety Pick award.



Information Provided by:

*Always wear your seat belt and secure children in the rear seat in appropriate child restraints. †Always check your mirrors. Be aware of the traffic around you. ‡Dynamic Stability Control (DSC) is an electronic system designed to help the driver maintain control under adverse conditions. It is not a substitute for safe driving practices. Factors including speed, road conditions and driver steering input can all affect whether DSC will be effective in preventing loss of control. Please see your owner's manual for further details.

DNA straight from the raceway.

At Mazda, motorsports is in our blood. It's part of our heritage, and you'll find "the soul of a sports car" in every Mazda we make. It's a passion that spans decades, inspiring us to compete in over 24 distinct club and pro-level motorsports series. This year, with less than 50 races under his belt, rookie driver Michael Cooper won the 2012 Pirelli World Challenge Touring Car Drivers Championship with his Mazdaspeed3. His statement, "...Having a car that is as fun to drive as the Mazdaspeed3 just adds to the thrill of victory and this championship." What's more, these cars use the same stock Mazda MZR 2.3-liter powerplant that comes standard in the same Mazdaspeed3 you drive every day. At Mazda, we believe the best street cars make the best race cars. That's why on any given weekend, more Mazdas are road-raced than any other car.*



*Based on Sports Car Club of America racing data.



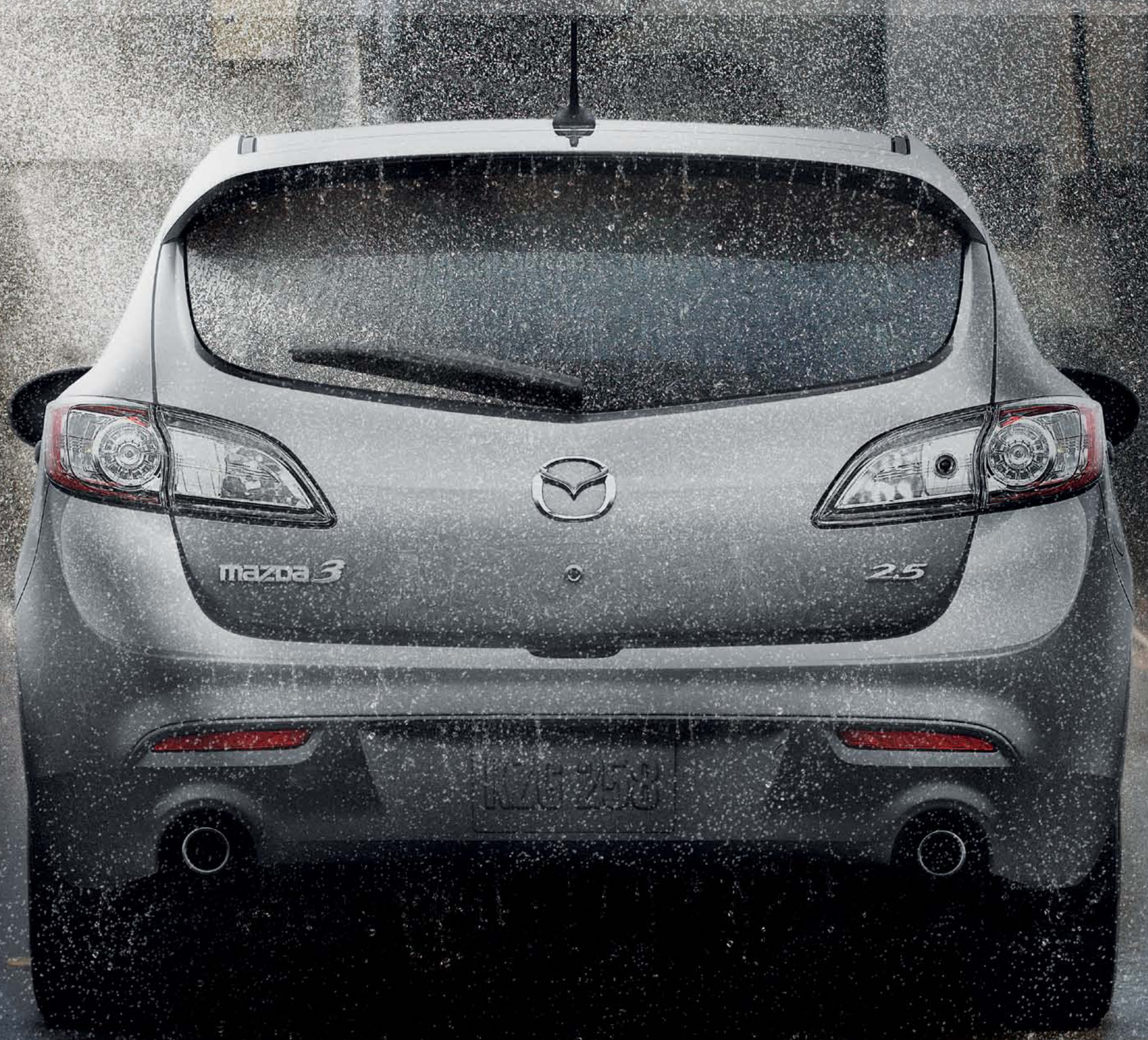

Information Provided by:



DEALER

Mazda3 5-Door s Grand Touring shown in Liquid Silver Metallic

Mazda3 4-Door

UPHOLSTERY Black Cloth

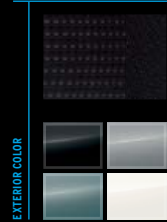

Mazda3 i SV 4-Door

Includes the following features:

- MZR 2.0L DOHC 4-cylinder engine with VVT
- Standard 5-speed manual transmission or available 5-speed Sport automatic transmission
- Air conditioning with pollen filter
- Power windows and dual power side mirrors
- 16-inch steel wheels with full covers
- Variable-intermittent windshield wipers
- Cloth-trimmed seats with 60/40 split fold-down rear seatback
- Steering-wheel-mounted audio controls

- AM/FM/CD/MP3-compatible audio system with 4 speakers and auxiliary-audio input jack
- Active front headrests
- Advanced front air bags, front side-impact air bags and side-impact air curtains*
- Dynamic Stability Control† and Traction Control System
- Tire-Pressure Monitoring System
- Available Convenience Package includes power door locks with 2-stage unlocking feature, automatic door locks and remote keyless entry system (AT models only)

Mazda3 i Sport 4-Door

Includes the following features in addition to or in place of Mazda3 i SV 4-Door:

- SKYACTIV®-G 2.0L DOHC 4-cylinder engine with VVT
- Standard 6-speed SKYACTIV®-MT manual transmission or available 6-speed SKYACTIV®-Drive sport automatic transmission
- Power door locks
- Remote keyless entry
- Cruise control
- USB audio input
- Multi Information Display and Trip Computer

Mazda3 i Touring 4-Door

Includes the following features in addition to or in place of the Mazda3 i Sport 4-Door:

- 16-inch aluminum alloy wheels
- Bright tip single exhaust outlet
- Dual-zone automatic climate control
- Mazda Advanced Keyless Entry & Start System
- Push Button Start
- 6-speaker audio system
- Bluetooth hands-free phone and audio capability
- Rear-seat center armrest with cup holders

- Leather-wrapped steering wheel and shift knob
- Available Preferred Equipment Package includes Blind Spot Monitoring system,† Bose® Centerpoint® 10 speaker Surround Sound System with AudioPilot® and power sliding-glass moonroof

Mazda3 i Grand Touring 4-Door

Includes the following features in addition to or in place of the Mazda3 i Touring 4-Door:

- Power sliding-glass moonroof
- Heated side mirrors
- Leather-trimmed seats and door panel inserts
- 8-way power-adjustable driver's seat
- Heated front seats with 5 levels
- Blind Spot Monitoring System†
- Bose® Centerpoint® 10 Speaker Surround Sound System with AudioPilot®
- 5.8" full-color touch-screen navigation system with voice command and real-time traffic updates
- Sliding center-console armrest

- Audio menu voice command
- E911 Automatic Emergency Notification
- HD Radio
- Pandora Internet radio
- SMS text-to-voice delivery and reply
- Available Technology Package includes auto on/off Bi-Xenon High-Intensity Discharge headlights, Adaptive Front-lighting System, halogen fog lights, power heated side mirrors with integrated turn signals, rain-sensing windshield wipers, rear deck lip spoiler, clear-lens LED combination taillights, SiriusXM Satellite Radio with 4-month trial subscription to the Sirius Select Package** and alarm system

Mazda3 s Grand Touring 4-Door

Includes the following features in addition to or in place of the Mazda3 i Grand Touring 4-Door:

- MZR 2.5L DOHC 4-cylinder engine with VVT
- Standard 6-speed manual transmission or available 5-speed Sport automatic transmission
- Halogen fog lights
- 17-inch aluminum alloy wheels
- Rear deck lip spoiler
- Dual exhaust with bright tips
- Power heated side mirrors with integrated turn signals
- Clear-lens LED combination taillights

- Bi-Xenon High-Intensity Discharge headlights with Adaptive Front-lighting System
- Auto on/off headlights
- Rain-sensing windshield wipers
- Leather-trimmed sport seats
- Illuminated driver and passenger vanity mirrors
- Overhead sunglasses holder
- SiriusXM Satellite Radio with 4-month trial subscription to the Sirius Select Package**
- Alarm system

Mazda3 5-Door

UPHOLSTERY Black Cloth Dune Cloth

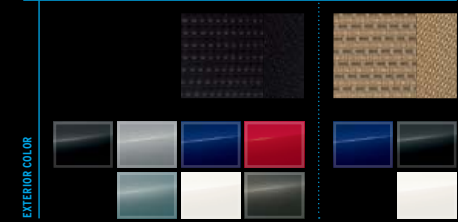

Mazda3 i Touring 5-Door

Includes the following features:

- SKYACTIV®-G 2.0L DOHC 4-cylinder engine with VVT
- Standard 6-speed SKYACTIV®-MT manual transmission or available 6-speed SKYACTIV®-Drive sport automatic transmission
- 16-inch aluminum alloy wheels
- Bright tip single exhaust outlet
- Dual-zone automatic climate control
- Mazda Advanced Keyless Entry & Start System
- Power windows, side mirrors and door locks
- Push button start
- AM/FM/CD/MP3-compatible audio system with 6 speakers and auxiliary-audio input jack

- Bluetooth hands-free phone and audio capability
- USB audio input
- Cruise control
- Rear-seat center armrest with cup holders
- Leather-wrapped steering wheel and shift knob
- Advanced front air bags
- Multi Information Display and Trip Computer
- Dynamic Stability Control†
- Available Preferred Equipment Package includes Blind Spot Monitoring system,† Bose® Centerpoint® 10 speaker Surround Sound System with AudioPilot® and power sliding-glass moonroof

Mazda3 i Grand Touring 5-Door

Includes the following features in addition to or in place of the Mazda3 i Touring 5-Door:

- Power sliding-glass moonroof
- Heated side mirrors
- Leather-trimmed seats and door panel inserts
- 8-way power driver's seat
- Heated front seats with 5 levels
- Blind Spot Monitoring System†
- Bose® Centerpoint® 10 Speaker Surround Sound System with AudioPilot®
- Sliding center-console armrest
- 5.8" full-color touch-screen navigation system with voice command and real-time traffic updates

- Audio menu voice command
- HD Radio
- Pandora Internet radio
- SMS text-to-voice delivery and reply
- E911 Automatic Emergency Notification
- Available Technology Package includes auto on/off Bi-Xenon High-Intensity Discharge headlights, Adaptive Front-lighting System, halogen fog lights, power heated side mirrors with integrated turn signals, rain-sensing windshield wipers, clear-lens LED combination taillights, SiriusXM Satellite Radio with 4-month trial subscription to the Sirius Select Package** and alarm system

Mazda3 s Grand Touring 5-Door

Includes the following features in addition to or in place of the Mazda3 i Grand Touring 5-Door:

- 2.5L DOHC MZR 4-cylinder engine with VVT
- Standard 6-speed manual transmission or available 5-speed Sport automatic transmission
- Halogen fog lights
- 17-inch aluminum alloy wheels
- Rear s-style roofline spoiler
- Side sill extensions
- Dual exhaust with bright tips
- Power heated side mirrors with integrated turn signals
- Clear-lens LED combination taillights

- Bi-Xenon High-Intensity Discharge headlights with Adaptive Front-lighting System
- Auto on/off headlights
- Rain-sensing windshield wipers
- Leather-trimmed sport seats
- Illuminated driver and passenger vanity mirrors
- Overhead sunglasses holder
- SiriusXM Satellite Radio with 4-month trial subscription to the Sirius Select Package**
- Alarm system

UPHOLSTERY Black Leather Dune Leather

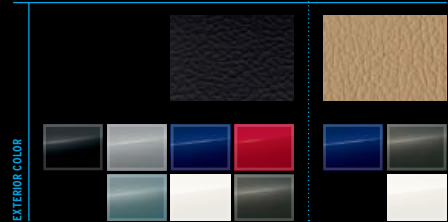

UPHOLSTERY Black Leather Dune Leather

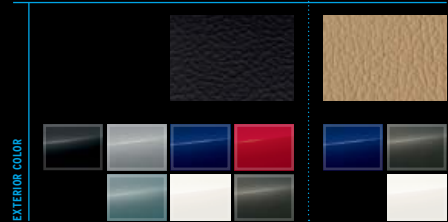

UPHOLSTERY Black Leather Dune Leather

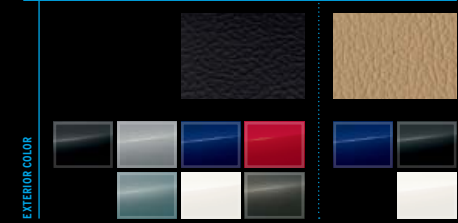

16" wheel cover

16" alloy wheel

17" alloy wheel



Black Cloth Mazda3 i Dune Cloth Mazda3 i

*Always wear your seat belt and secure children in the rear seats in appropriate child restraints. †Dynamic Stability Control (DSC) is an electronic system designed to help the driver maintain control under adverse conditions. It is not a substitute for safe driving practices. Factors including speed, road conditions and driver steering input can all affect whether DSC will be effective in preventing loss of control. Please see your owner's manual for further details. ‡Always check your mirrors. Be aware of the traffic around you. **SiriusXM Satellite Radio reception requires a subscription and Mazda satellite radio. Included in Tech Package. Subscriptions to SiriusXM services are sold by SiriusXM after 4-month subscription to the Sirius Select package expires and are continuous until you call SiriusXM at 1-866-635-2349 to cancel. See SiriusXM Customer Agreement for complete terms at www.siriusxm.com. Sirius satellite service available only to those at least 18 and older in the 48 contiguous USA, DC, and P.R. (with coverage limitations). Sirius, XM and all related marks and logos are trademarks of Sirius XM Radio Inc. ††Extra cost option. Bluetooth is a registered trademark of Bluetooth SIG, Inc. Apple and iPod® are registered trademarks of Apple Inc. iPhone® not compatible with iPod® adapter.



MAZDASPEED3 Key Features

Intense Performance

MZR 2.3-liter all-aluminum 4-cylinder turbocharged, intercooled & direct-injected engine

Forged crankshaft & connecting rods

Sport-tuned intake & exhaust systems

Close-ratio 6-speed manual gearbox

Torque-sensing conical limited-slip differential

Mazda Advanced Torque Management System

263 hp @ 5,500 rpm/280 lb-ft of torque @ 3,000 rpm

155 mph top speed (electronically limited)

Heavy-duty front & rear stabilizer bars

12.6-inch ventilated front disc brakes

11.0-inch solid rear disc brakes

ABS, Electronic Brakeforce Distribution & Brake Assist

Traction Control System & Dynamic Stability Control*

Sporty Interior

Mazdaspeed3 red gradation gauges & boost gauge

Racing-inspired, high-bolstered front bucket seats

Drilled aluminum foot pedals

Bluetooth hands-free phone & audio capabilities

USB audio input

Multi Information Display

Dual-zone automatic climate control

Special Mazdaspeed3 scuff plates and floor mats

Illuminated steering-wheel-mounted controls for audio system, Bluetooth & cruise control

Bose® 265-watt Centerpoint® 10-speaker Surround Sound System with Audio Pilot

Bold Exterior

Fully functional hood scoop

18-inch aluminum alloy wheels with P255/40 R18 radial tires

Bilevel rear spoiler

Mazdaspeed3 aero body parts

Dual bright tip exhaust outlets

Integral fog lights

Dual power side mirrors with integrated turn signals

Rear window wiper



Mazdaspeed3 Technology Package

Full-color 5.8" touch-screen navigation system with real-time traffic updates, audio menu voice command, HD Radio, Pandora Internet radio, SMS text-to-voice delivery and reply, E911 automatic emergency notification, SiriusXM Satellite Radio† with four-month trial subscription to the Sirius Select Package; Mazda Advanced Keyless Entry & Start System with Push Button Start; Bi-Xenon High-Intensity-Discharge auto-leveling headlights; Adaptive Front-lighting System; Automatic on/off headlights; Blind Spot Monitoring System;‡ clear-lens LED taillights; rain-sensing windshield wipers; alarm system

TIRE 18" alloy wheel

EXTERIOR COLOR

UPHOLSTERY Black+Red, Cloth+Leather

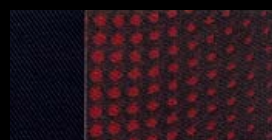
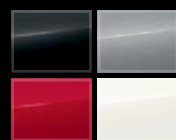

Financing without the fuss.

Whether you're buying or leasing a new Mazda, Certified Pre-Owned Mazda or a used vehicle, Mazda Capital Services* can help make the financing process more convenient and satisfying. One of the largest auto lenders in America, Mazda Capital Services is known for first-class customer service, a wide range of financing options and highly competitive rates.

To find out which purchase or lease plan is right for you, talk with your Mazda Dealer, or visit MazdaUSA.com.

*The tradename "Mazda Capital Services," as well as the Mazda and Mazda Capital Services logos, are owned by Mazda Motor Corporation or its affiliates and are licensed to JPMorgan Chase Bank, N.A. ("Chase"). Retail/loan and lease accounts are owned by Chase.

We're committed to our drivers. Every new 2013 Mazda3 is protected by:

- > **A 3-year/36,000-mile† "bumper-to-bumper" limited warranty**
- > **A 3-year/36,000-mile† 24/7 Emergency Roadside Assistance program**
- > **A 5-year/60,000-mile† limited powertrain warranty**
- > **A 5-year/unlimited-mileage warranty against body rust-through**

†Whichever comes first.

For details, please see your Mazda Dealer, visit MazdaUSA.com, or call toll-free (800) 639-1000.

Mazda3 Specifications & Capacities

	Mazda3 i 4-Door SV	Mazda3 i 4-Door & 5-Door Sport 4-Door, Touring & Grand Touring	Mazda3 s 4-Door & 5-Door Grand Touring
ENGINE			
Engine type	MZR 2.0L DOHC 16-valve 4-cylinder with VVT	SKYACTIV®-G 2.0L DOHC 4-cylinder with VVT	MZR 2.5L DOHC 16-valve 4-cylinder with VVT
Horsepower	148 hp @ 6,500 rpm	155 hp @ 6,000 rpm	167 hp @ 6,000 rpm
Torque	135 lb-ft @ 4,500 rpm	148 lb-ft @ 4,100 rpm	168 lb-ft @ 4,000 rpm
Redline	6,500 rpm	6,500 rpm	6,200 rpm
Displacement (cc)	1,999	1,998	2,489
Bore x Stroke (mm)	87.5 x 83.1	83.5 x 91.2	89.0 x 100.0
Compression Ratio	10.0:1	12.0:1	9.7:1
Fuel System	Electronically controlled multiport fuel injection	Advanced Direct Injection	Electronically controlled multiport fuel injection
Recommended Fuel		Regular unleaded	
Valvetrain	Chain-driven dual overhead cams, 4 valves per cylinder with variable intake valve timing (VVT)		
Ignition System	Direct coil-on-plug electronic ignition with platinum-tipped spark plugs		
Engine Block	Aluminum alloy		
Cylinder Head	Aluminum alloy		
Emission Control Type (Fed/Cal)	Tier2-BIN5 / Ultra Low Emissions Vehicle (ULEV)		Tier2-BIN5 / Low Emissions Vehicle (LEV)

DRIVETRAIN

Type	Front-wheel drive		
Manual Transmission	5-speed overdrive	SKYACTIV®-MT 6-speed overdrive	6-speed overdrive
Automatic Transmission	5-speed electronically controlled Sport with Adaptive Shift Logic and manual-shift mode	SKYACTIV®-Drive 6-speed electronically controlled Sport with manual-shift mode	5-speed electronically controlled Sport with Adaptive Shift Logic and manual-shift mode

CHASSIS

Brakes			
- Front / Rear	10.9-inch vented disc / 10.4-inch solid disc		11.8-inch vented disc / 11.0-inch solid disc
- ABS	4-wheel, 4-channel with Electronic Brakeforce Distribution and Brake Assist		
Steering type	Power rack-and-pinion with variable assist		
Power assist	Electrohydraulic Power Assist Steering		
Overall steering ratio	16.2:1		
Steering wheel turns, lock-to-lock	2.9		
Turning circle, curb-to-curb (ft)	34.2		
Suspension	4-wheel independent		
- Front / Rear	MacPherson strut with stabilizer bar / Multi-link with stabilizer bar		
Wheel size (in)	16 x 6.5		17 x 7.0
Tire size	P205/55 R16 all-season radial		P205/50 R17 all-season radial

	Mazda3 i 4-Door SV	Mazda3 i 4-Door Sport, Touring & Grand Touring	Mazda3 s 4-Door Grand Touring	Mazda3 i 5-Door Touring & Grand Touring	Mazda3 s 5-Door Grand Touring
--	--------------------------	--	-------------------------------------	---	-------------------------------------

WEIGHTS & CAPACITIES

Curb weight (lb)					
- Manual transmission	2,866	2,872	3,046	2,896	3,048
- Automatic transmission	2,929	2,950	3,103	2,969	3,104
Fuel capacity (gallons)	14.5	14.5	15.9	14.5	15.9

INTERIOR DIMENSIONS

Headroom, front / rear without moonroof (in)	38.9 / 37.5	38.9 / 37.5 [n/a for GT]	n/a	38.9 / 38.0 [n/a for GT]	n/a
Headroom, front / rear with moonroof (in)	n/a	38.1 / 37.4 [n/a for Sport]	38.1 / 37.4	38.1 / 37.7	38.1 / 37.7
Shoulder room, front / rear (in)	54.9 / 54.0	54.9 / 54.0	54.9 / 54.0	54.9 / 54.0	54.9 / 54.0
Hip room, front / rear (in)	53.7 / 52.2	53.7 / 52.2	53.7 / 52.2	53.7 / 52.2	53.7 / 52.2
Legroom, front / rear (in)	42.0 / 36.2	42.0 / 36.2	42.0 / 36.2	42.0 / 36.2	42.0 / 36.2
EPA passenger volume (cu ft)	94.1	94.1	94.1	94.6	94.6
EPA cargo volume 2nd-row down (cu ft)	n/a	n/a	n/a	42.8	42.8

EXTERIOR DIMENSIONS

Wheelbase (in)	103.9	103.9	103.9	103.9	103.9
Track, front (in)	60.4	60.4	60.2	60.4	60.2
Track, rear (in)	59.8	59.8	59.6	59.8	59.6
Length (in)	180.9	180.9	180.9	177.4	177.4
Width (in)	69.1	69.1	69.1	69.1	69.1
Height (in) - (unladen)	57.9	57.9	57.9	57.9	57.9
Minimum ground clearance (in) - (laden)	4.7	4.7	4.7	4.7	4.7

FUEL ECONOMY

Manual Transmission (city/hwy)	25 / 33	27 / 39	20 / 28	27 / 38	20 / 28
Automatic Transmission (city/hwy)	24 / 33	28 / 40	22 / 29	28 / 39	22 / 29

Information Provided by:



*Dynamic Stability Control (DSC) is an electronic system designed to help the driver maintain control under adverse conditions. It is not a substitute for safe driving practices. Factors including speed, road conditions and driver steering input can all affect whether DSC will be effective in preventing loss of control. Please see your owner's manual for further details. †Not equipped for XM Radio reception. SiriusXM Satellite Radio reception requires a subscription and Mazda satellite radio. See full disclaimer in Specifications. ‡ Always check your mirrors. Be aware of the traffic around you.

Product Changes and Options Availability: Following publication of this brochure, certain changes in standard equipment, options, prices and the like-or product delays-may have occurred which would not be included in these pages. Your Mazda Dealer is your best source for up-to-date information. Mazda reserves the right to change product specifications at any time without incurring obligations. Options shown or described in this brochure are available at extra cost and may be offered only in combination with other options or subject to additional ordering requirements or limitations.



Every model in the Mazda lineup was built by a bunch of car-crazed craftsmen. Who love to drive. For people who love to drive. So from the Mazda2 to the CX-9, a Mazda is always a Mazda. Because if it's not worth driving, it's not worth building.

It's your Mazda-make it your own. Customize your new Mazda3 with Genuine Mazda Accessories. When installed by your Mazda Dealer prior to or at initial vehicle retail delivery, Genuine Mazda Accessories carry the same new-vehicle limited warranty as your new Mazda. Ask your dealer for details.

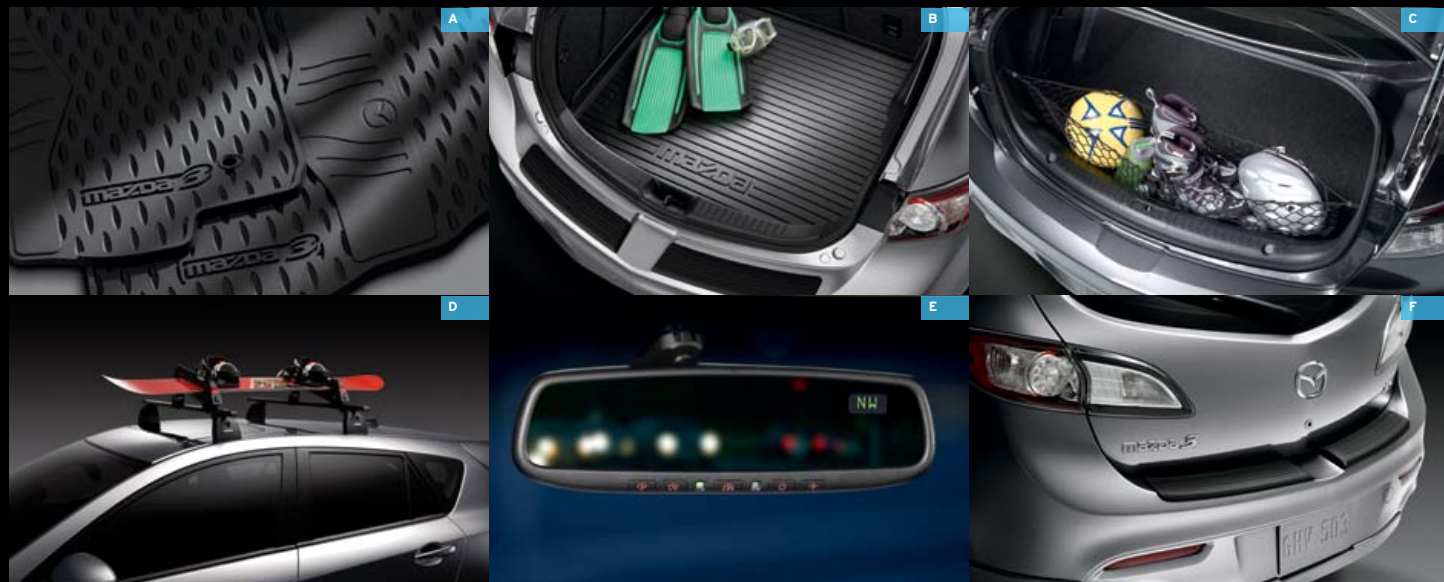

A All-Weather Floor Mats. Not just for bad weather anymore, these "whatever" floor mats are the perfect accessory to protect your Mazda3's interior from not only water, sand, mud and snow, but crumbs, spills, grass and anything else that your lifestyle may bring. **B Cargo Tray.*** Keeps the cargo area carpet clean and free from damage. Cleans easily with soap and water. **C Cargo Net.*** Keep smaller items from bouncing around in your cargo area. Easily installed and removed. **D Roof Rack.*** Expand your storage possibilities with a removable roof rack. Add any of our customized attachments to transport your kayak, bike, cargo, surfboard, luggage, snowboard and more. **E Auto-Dimming Mirror** with compass and HomeLink. Equipped with a bright LED compass to help keep you on the right road and HomeLink® to help make your life more convenient and safe. **F Rear Bumper Guard.** Protect your paint's finish while loading and unloading the cargo area. 5-Door only.

Additional accessories:

- | | | | | |
|-------------------------|-------------------------------|----------------------------------|------------------------------|--------------------------------|
| Fog Lights | Roof-Rack Attachments: | Rear Wing Spoiler | 3.5-mm Audio Cable | Remote Engine Start |
| Front Mask | - Bike Carrier | License-Plate Frames | Bluetooth Car Kit | Cargo Mat |
| Windshield Sunscreen | - Cargo Box, Medium | Car Cover | by Motorola | Rear Aero Flares and |
| Moonroof Wind Deflector | - Cargo Box, Short | Car-Cover Cable Lock | In-Dash 6-Disc | Center Underskirt |
| Side Sills | - Luggage Basket | Touch-Up Paint | CD/MP3 Changer | (5-Door only) |
| Splash Guards | with Stretch Net | Wheel Locks | Portable Navigation | Roadside Assistance Kit |
| Fuel Door | - Kayak Carrier | SiriusXM Satellite Radio* | Devices by Garmin® | First Aid Kit |
| | - Ski/Snowboard Carrier | | Interior Lighting Kit | Ashtray |
| | - Surfboard Carrier | | | |

Dear Driver,

As the Mazda3 program manager, I had one all-consuming goal for this car: to make something economical feel like a much richer experience. My team and I worked long days to ensure that the final result never felt like everyday transportation.

To accomplish our goals, we ignored what the automotive industry told us were acceptable features for this segment. They said Bi-Xenon headlights, Blind Spot Monitoring and text message-reading audio systems were only for expensive cars. So we made them easily obtainable options. Then we ignored the traditional thinking that fuel-efficient couldn't also be performance-oriented. So we incorporated SKYACTIV® TECHNOLOGY to let the Mazda3 hit 40 MPG and still be a hit on winding roads.

We made it good. Then we made it better. And then we went a bit further and made it a Mazda. I'm extremely proud that we could give the world a practical car that's quite entertaining. Our no-compromise engineering gave birth to a car that's born to be driven.

KENICHIRO SARUWATARI
MAZDA3 PROGRAM MANAGER

*Please remember to properly secure all cargo. †SiriusXM Satellite Radio reception requires a subscription and Mazda satellite radio. Included in Tech Package. Subscriptions to SiriusXM services are sold by SiriusXM after 4-month subscription expires and are continuous until you call SiriusXM at 1-866-635-2349 to cancel. See SiriusXM Customer Agreement for complete terms at www.siriusxm.com. Sirius satellite service available only to those at least 18 and older in the 48 contiguous USA, DC, and PR. (with coverage limitations). Sirius, XM and all related marks and logos are trademarks of Sirius XM Radio Inc. Bluetooth is a registered trademark of Bluetooth SIG, Inc.



MazdaUSA.com
facebook.com/mazda

